

(19) World Intellectual Property Organization
International Bureau



(43) International Publication Date
20 January 2005 (20.01.2005)

PCT

(10) International Publication Number
WO 2005/006038 A2

(51) International Patent Classification⁷: G02B 6/00

TN, TR, TT, TZ, UA, UG, US, UZ, VC, VN, YU, ZA, ZM, ZW.

(21) International Application Number:
PCT/US2004/014072

(22) International Filing Date: 6 May 2004 (06.05.2004)

(25) Filing Language: English

(26) Publication Language: English

(30) Priority Data:
10/610,957 1 July 2003 (01.07.2003) US
10/610,962 1 July 2003 (01.07.2003) US
10/611,265 1 July 2003 (01.07.2003) US

(84) Designated States (unless otherwise indicated, for every kind of regional protection available): ARIPO (BW, GH, GM, KE, LS, MW, MZ, NA, SD, SL, SZ, TZ, UG, ZM, ZW), Eurasian (AM, AZ, BY, KG, KZ, MD, RU, TJ, TM), European (AT, BE, BG, CH, CY, CZ, DE, DK, EE, ES, FI, FR, GB, GR, HU, IE, IT, LU, MC, NL, PL, PT, RO, SE, SI, SK, TR), OAPI (BF, BJ, CF, CG, CI, CM, GA, GN, GQ, GW, ML, MR, NE, SN, TD, TG).

Declarations under Rule 4.17:

- as to applicant's entitlement to apply for and be granted a patent (Rule 4.17(ii)) for the following designations AE, AG, AL, AM, AT, AU, AZ, BA, BB, BG, BR, BW, BY, BZ, CA, CH, CN, CO, CR, CU, CZ, DE, DK, DM, DZ, EC, EE, EG, ES, FI, GB, GD, GE, GH, GM, HR, HU, ID, IL, IN, IS, JP, KE, KG, KP, KR, KZ, LC, LK, LR, LS, LT, LU, LV, MA, MD, MG, MK, MN, MW, MX, MZ, NA, NI, NO, NZ, OM, PG, PH, PL, PT, RO, RU, SC, SD, SE, SG, SK, SL, SY, TJ, TM, TN, TR, TT, TZ, UA, UG, UZ, VC, VN, YU, ZA, ZM, ZW, ARIPO patent (BW, GH, GM, KE, LS, MW, MZ, NA, SD, SL, SZ, TZ, UG, ZM, ZW), Eurasian patent (AM, AZ, BY, KG, KZ, MD, RU, TJ, TM), European patent (AT, BE, BG, CH, CY, CZ, DE, DK, EE, ES, FI, FR, GB, GR, HU, IE, IT, LU, MC, NL, PL, PT, RO, SE, SI, SK, TR), OAPI patent (BF, BJ, CF, CG, CI, CM, GA, GN, GQ, GW, ML, MR, NE, SN, TD, TG)
- as to the applicant's entitlement to claim the priority of the earlier application (Rule 4.17(iii)) for all designations
- as to the applicant's entitlement to claim the priority of the earlier application (Rule 4.17(ii)) for all designations
- as to the applicant's entitlement to claim the priority of the earlier application (Rule 4.17(iii)) for all designations

Published:

- without international search report and to be republished upon receipt of that report

[Continued on next page]

(54) Title: APPARATUS AND METHOD FOR ADJUSTING THE SPECTRAL RESPONSE OF AN OPTICAL WAVEGUIDE GRATING

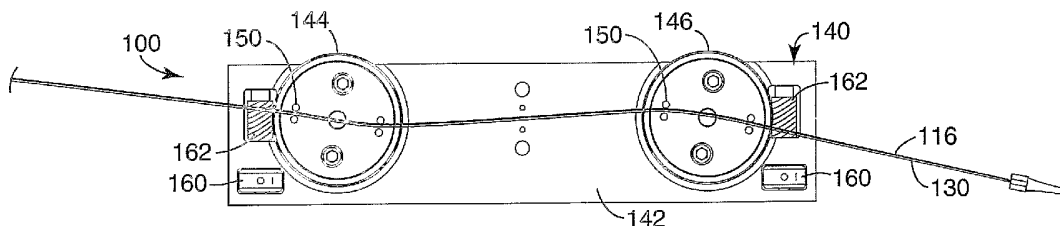

(57) Abstract: An apparatus and method for adjusting the spectral response of an optical waveguide grating includes an optical waveguide grating attached to a support member having a centroidal axis. Bending moments are applied to the support member to bend the optical grating in at least a transverse direction to adjust the spectral response of the optical waveguide grating. The spectral response of the grating may further be adjusted by rotating the bent support member about its centroidal axis.

WO 2005/006038 A2



For two-letter codes and other abbreviations, refer to the "Guidance Notes on Codes and Abbreviations" appearing at the beginning of each regular issue of the PCT Gazette.

**APPARATUS AND METHOD FOR ADJUSTING THE SPECTRAL
RESPONSE OF AN OPTICAL WAVEGUIDE GRATING**

The Field of the Invention

This invention generally relates to optical waveguide gratings. More
5 particularly, this invention relates to an apparatus and method for adjusting the
spectral response of an optical waveguide grating.

Background of the Invention

Optical fibers are thin strands of glass capable of transmitting information
containing optical signals over long distances with low loss of signal strength. In
10 essence, an optical fiber is a small diameter waveguide consisting of a fiber core
having a first index of refraction surrounded by a fiber cladding layer having a
second lower index of refraction. So long as the refractive index of the core is
sufficiently higher than the refractive index of the cladding, a light beam
propagating along the core exhibits total internal reflection and is guided along the
15 length of the core. Typical optical fibers are made of high purity silica, with
various concentrations of dopants added to control the index of refraction of the
core and the cladding.

Many optical materials exhibit different responses to optical waves of
different wavelengths. One such phenomenon is chromatic dispersion (or simply
20 "dispersion") in which the speed of light through an optical medium is dependent
upon the wavelength of the optical wave passing through the medium. Since the
index of refraction for a material is the ratio of the speed of light in a vacuum (a
constant) to the speed of light in the material, it therefore follows that the index of
refraction also typically varies as a function of wavelength in these materials.

25 Optical fibers are frequently used in data networks (such as
telecommunication networks) requiring high data transmission rates. In many
networks, data is also transmitted over very long distances. As the distances over
which data is transmitted increase, or the rates at which data is transmitted
increase, chromatic dispersion presents obstacles to achieving error free
30 performance. Specifically, in long distance transmission of optical signals, the
laser bandwidth and the modulation used to encode data onto the laser beam results

in a range of wavelengths being used to transmit the information. The combination of this range of wavelengths and the chromatic dispersion of the fiber accumulated over a distance results in pulse broadening or spreading. For example, at high data rates two adjacent optical pulses or wave fronts may eventually overlap each other
5 due to chromatic dispersion. Such overlapping can cause errors in data transmission. The accumulation of chromatic dispersion increases as the distance the optical signals travel increases. For low speed signals, dispersion is not typically a problem as they may use a smaller range of wavelengths, resulting in a smaller range of delays in the transmission path and have a longer time period in
10 which to determine the state of each bit.

Attempts to compensate for chromatic dispersion include the use of dispersion compensating fibers, dispersion compensating optical waveguide gratings (e.g., fiber Bragg gratings), and a combination of both. Dispersion compensating fibers and dispersion compensating optical waveguide gratings
15 introduce chromatic dispersion with an opposite sign to the accumulated dispersion in a fiber link.

Optical gratings suitable for dispersion compensation may include Bragg gratings, and long period gratings. These gratings typically comprise a body of material with a plurality of spaced apart optical grating elements disposed in the
20 material. For example, a conventional Bragg grating comprises an optical fiber in which the index of refraction undergoes periodic perturbations along its length. The perturbations may be equally spaced, as in the case of an unchirped grating, or may be unequally spaced as in the case of a chirped grating. That is, a chirp is a longitudinal variation in the grating period along the length of the grating. The
25 wavelength reflected in a Bragg grating is directly related to the period of the perturbation. Thus, in a chirped fiber grating, the reflected wavelength of the grating changes with the position along the fiber grating. As the grating period increases or decreases along a direction in the fiber grating, the reflected wavelength increases or decreases accordingly. Therefore, different spectral
30 components in an optical signal are reflected back at different locations along the grating and accordingly have different delays. Such wavelength dependent delays may be used to negate the accumulated dispersion of an optical signal. Chirped

gratings may be linearly chirped (having perturbations that vary in a linear fashion), non-linearly chirped, or randomly chirped.

Fiber Bragg gratings reflect light over a given waveband centered around a wavelength equal to twice the spacing between successive perturbations. The reflected wavelength is given by the Bragg Equation $\lambda = 2dn$, where n is the effective index of the grating, λ is the reflected wavelength, and d is the distance between successive perturbations. The remaining wavelengths pass essentially unimpeded. The ability to pass some wavelengths in an unimpeded manner is desirable in optical filtering applications. In such applications, the frequency of the grating can be selected to reflect (i.e., filter) undesired wavelengths, while allowing desired wavelengths to pass.

Fiber gratings may be extrinsically chirped or intrinsically chirped. An extrinsic chirp refers to a chirp in the grating that is obtained by applying an external perturbation generating field to the fiber. For example, to create a chirped grating, an external gradient is applied along the length of a non-chirped fiber grating, resulting in non-uniform changes in properties of the fiber grating, thus creating a chirp. An extrinsic chirp is valuable in that it may be applied to adjust the parameters of the grating, and it may be used to control the chromatic dispersion of a fiber Bragg grating. External gradients typically comprise strain gradients or temperature gradients.

There are disadvantages, however, in forming chirped gratings with an external gradient. The maximum range of chirping that can be achieved is limited in that relatively large gradients or strains are required to obtain a range of chirping. Such externally applied strains may have a negative impact on the reliability of the fiber, such as by causing the fiber to fracture. Thus, the maximum chirp rate that can be imposed on the grating is limited by the material properties of the fiber.

An intrinsic chirp refers to a chirp in the grating that has been incorporated into the fiber during the fabrication process. For example, an intrinsic chirp may be achieved by using a phase mask in which the period of the phase mask varies in some manner. When radiation is applied to the fiber through the phase mask (thus altering the index of refraction), the resulting fiber will be intrinsically chirped.

Using this technique, broadband gratings may be produced which can compensate for chromatic dispersion in multi-channel system. However, intrinsic chirp corrects a fixed amount of dispersion in a specified wavelength spectrum. While intrinsically chirped gratings are useful in communication systems where a specific amount of dispersion compensation is required, the dispersion and amplitude response of the grating is essentially fixed. Thus, intrinsically chirped gratings by themselves are not well suited to situations in which dynamically adjustable devices are required.

A variety of approaches exist for adjusting the spectral response (i.e., “tuning”) of gratings in optical fibers. The application of strain to the grating is one method. For example, simply stretching the grating by gripping the fiber on either end of the grating and then putting the fiber in tension. Other approaches use bending of a simple structural member to put a strain on an attached grating. Each of these approaches is limited in the applications it can address.

In particular, a problem with current devices and methods requiring the application of tensile strain to the grating is the potential for tensile failure of the fiber. This problem severely limits the amount of strain that can be reliably imposed. Methods wherein the fiber is attached to a support member and the support member is then put into tension are likewise limited.

Short gratings (less than approximately 100 mm in length) have also been tuned using axial compression. For example, a grating may be attached to the inside of a ferrule and the ferrule placed in compression. When using a uniform ferrule, the wavelengths reflected will shift uniformly downward. When using a non-uniform ferrule, both the dispersion characteristics of the grating and the center wavelength change with changes in the force applied to the ferrule. Since only compression is used, tensile failure of the grating ceases to be an issue. However, the length of grating that can be economically tuned using this method is very limited. The length is also limited by column buckling which requires that, for a given strain, the diameter of a cylinder increases as a function of its length. Furthermore, the force required to generate a given strain increases with the square of the diameter. These factors limit the use of the described compression tuning methods for long gratings (greater than approximately 100 mm in length).

Another problem current devices and methods for tuning share is that the wavelengths shift in all sections of the grating at the same time, although not necessarily by the same amount. Designs have been attempted that independently tune small elements within a grating. These designs have generally not been
5 commercially successful due to their great complexity, large number of parts and high cost. For example, United States Patent No. 5,694,501 discloses an apparatus and method of controlling strain in a Bragg grating that requires a segmented piezoelectric stack with quasi-distributed voltage control. The segmented piezoelectric stack and control system are complex, and a constant supply of power
10 is required to maintain a selected strain profile.

Clearly, previous attempts to provide dispersion compensating devices and methods have not produced adequate results. In particular, previous attempts have not satisfactorily addressed the unique issues associated with adjusting the spectral response of long gratings or sections of long gratings. If methods representing the
15 current technology were used to adjust the spectral response of long gratings, the result would be severely limited ranges of adjustability, or unacceptably high levels of tensile strain (>1%) on the fiber for high reliability. Currently available devices and methods also do not provide the capability to tune the dispersion of a single channel (wavelength) of a multi-channel grating at any wavelength within a
20 broad operating range. A need exists for an apparatus and method that addresses the above described shortcomings.

Summary of the Invention

The embodiments according to the invention described herein provide an apparatus and method for adjusting the spectral response of an optical waveguide
25 grating in a flexible manner. Some embodiments according to the invention provide settable or tunable dispersion compensators. Other embodiments according to the invention may be used in tunable add/drop multiplexers or a variety of other devices that would benefit from the use of an adjustable filter. Still other embodiments according to the invention utilize mechanical adjustment of the
30 spectral response such that once set the apparatus requires no power. Still other embodiments according to the invention provide compressive preload on the optical waveguide grating to reduce or eliminate reliability concerns related to

tensile failure. Still other embodiments according to the invention allow selection and adjustment of any particular channel within the operating band of a multi-channel grating. Still other embodiments according to the invention allow the wavelength to be set at each of two points in an optical wavelength grating, with
5 the result being a defined channel width and dispersion.

One embodiment of a method for adjusting the spectral response of an optical grating according to the invention comprises attaching an optical grating to a support member. The optical grating is spaced from a centroidal axis of the support member. The spectral response of the grating is altered by applying
10 bending moments at two or more locations on the support member to bend the optical grating in at least a transverse direction to create an axial strain profile along the length of optical grating. Thus support member may further be rotated about its centroidal axis to alter the spectral response of the grating. The optical waveguide grating may be parallel to the centroidal axis, non-parallel to the
15 centroidal axis, or wound about the centroidal axis.

One embodiment of an apparatus for adjusting the spectral response of an optical grating according to the invention comprises a support member having a centroidal axis, and a longitudinal optical waveguide grating attached to the support member. A mechanism applies at least two bending moments to the
20 support member to bend the optical grating in at least a transverse direction, whereby the spectral response of the grating is adjusted by altering the bending moments. The mechanism may further rotate the support member about its centroidal axis to adjust the spectral response of the grating.

Brief Description of the Drawings

25 Figure 1 illustrates an exemplary optical fiber Bragg grating.

Figures 2A-2C illustrate one method of forming an apparatus for adjusting the spectral response of an optical waveguide grating according to the invention.

Figure 3 illustrates the performance of an apparatus for adjusting the spectral response of an optical waveguide grating like that illustrated in Figures
30 2A-2C.

Figure 4 illustrates another embodiment of an apparatus for adjusting the spectral response of an optical waveguide grating according to the invention.

Figure 5 illustrates yet another embodiment of an apparatus for adjusting the spectral response of an optical waveguide grating according to the invention.

Figure 6 illustrates an alternate configuration for the apparatus of Figure 5.

Figure 7 illustrates yet another embodiment of an apparatus for adjusting
5 the spectral response of an optical waveguide grating according to the invention.

Figure 8 illustrates the adjustment of the spectral response of a Bragg grating using the apparatus Figure 7.

Figure 9 illustrates a support member that is asymmetric about its neutral axis.

10 Figure 10 illustrates one method of tuning the spectral response of an optical waveguide grating or section thereof according the to invention.

Figure 11 illustrates uniformly shifting the spectral response of an optical waveguide grating.

Figure 12 illustrates altering the chromatic dispersion of an optical
15 waveguide grating.

Figure 13 illustrates altering the center wavelength and the chromatic dispersion of an optical waveguide grating.

Figure 14 illustrates an embodiment of an apparatus for adjusting the spectral response of an optical waveguide grating that is adjusted by bending and
20 rotating the support member.

Figure 15 is a cross sectional view along line 15-15 of the apparatus of Figure 14.

Figure 16 illustrates yet another embodiment of an apparatus for adjusting the spectral response of an optical waveguide grating that is adjusted by bending
25 and rotating the support member.

Figure 17 illustrates yet another embodiment of an apparatus for adjusting the spectral response of an optical waveguide grating that is adjusted by bending and rotating the support member.

Figures 18A and 18B illustrate additional embodiments of an apparatus for
30 adjusting the spectral response of an optical waveguide grating that are adjusted by bending and rotating the support member.

Figures 19A-19E illustrate the delay slope and dispersion curves of the apparatuses of Figures 18A and 18B.

Figures 20A and 20B schematically illustrate an embodiment of a mechanism for bending and rotating the support member of the apparatuses of
5 Figures 14-18B.

Figure 21 schematically illustrates another embodiment of a mechanism for bending and rotating the support members of the apparatuses of Figures 14-18B.

Description of the Preferred Embodiments

In the following detailed description of the preferred embodiments,
10 reference is made to the accompanying drawings which form a part hereof, and in which is shown by way of illustration specific embodiments in which the invention may be practiced. It is to be understood that other embodiments may be utilized and structural or logical changes may be made without departing from the scope of the present invention. The following detailed description, therefore, is not to be
15 taken in a limiting sense, and the scope of the present invention is defined by the appended claims.

Referring now to the drawings and in particular to Figure 1 thereof, an optical waveguide 10 is shown to be configured as an optical fiber of which only a relatively short longitudinal length is depicted and which includes a fiber core 12
20 and a fiber cladding 14 surrounding the fiber core 12. The fiber core incorporates a grating 16 that includes a plurality of grating elements 18, each grating element 18 extending substantially normal to the longitudinal axis of the core 12. The spectral response (i.e., wavelength and chromatic dispersion) of the grating 16 can be adjusted (or "tuned") by altering the average index of refraction of the grating
25 structure, changing the spacing between grating elements 18, or by using a combination of the two.

For reasons of clarity, the various embodiments according to the invention are described herein with respect to optical waveguides configured as optical fibers. However, the teachings of the invention are equally applicable to other
30 types of optical waveguides. Similarly, the various embodiments according to the invention are for the most part described herein with respect to devices and methods that adjust the spectral response of portions of long gratings. However,

the embodiments according to the invention are applicable to adjusting the spectral response of a portion of any length grating, including the full length of a grating. Long gratings are generally considered to be gratings having a length of 100 mm or greater. Broadband gratings in the range of 1-3 meters long (or even longer) may be used in long distance optical communication systems.

AXIAL PRE-COMPRESSION

One aspect of the present invention provides an apparatus for adjusting the spectral response of an optical waveguide grating having high reliability by applying a compressive preload to the grating. The compressive preload reduces or eliminates potentially damaging tensile strain in the grating when the spectral response of the grating is subsequently adjusted using a controlled application of tensile strain.

One embodiment of an apparatus for adjusting the spectral response of an optical waveguide grating having a compressive preload and a method of forming such an apparatus is illustrated in Figures 2A-2C. The apparatus includes an optical waveguide 10 including an optical grating 16 attached to a support member 30. The optical grating 16 is subjected to axial compression by support member 30 so that optical grating 16 is under a compressive axial strain prior to any adjustment (i.e., "tuning") of the spectral response of the grating. The apparatus is tuned by altering the strain in the optical grating 16. In one embodiment, the strain of optical grating 16 is altered by the application of mechanical forces to the support member 30. In another embodiment, the strain of optical grating 16 is altered by controlled heating or cooling of the support member 30.

One method of forming an apparatus for adjusting the spectral response of an optical waveguide grating having a compressive preload is as follows. First, the range of wavelengths (operating band) of the channel or channels to be adjusted is determined, together with the range of dispersion values (dispersion range) over which the grating will be adjusted. Next, a preliminary optical grating design that allows the optical grating to be adjusted over the desired dispersion range and operating band is determined. Next, the maximum wavelength increase and associated maximum tensile strain required to tune the preliminary optical grating across the desired operating range is determined. Next, a final optical grating is

selected, wherein at each location in the final optical grating the reflected wavelength is longer than the wavelength in the preliminary optical grating design by the previously determined maximum wavelength increase.

After the final optical grating is selected using the above steps, a support member 30, such as a straight beam having a uniform cross-section, is provided. While still separated from the optical waveguide 10 having the selected final optical grating 16, a support surface 32 of support member 30 is elongated in a controlled manner (Figure 2A) as indicated by arrows 38. Support surface 32 may be elongated in a controlled manner by imparting a controlled tensile strain to support member 30. A controlled tensile strain may be imparted by the application of mechanical force to support member 30, such as by bending the support member 30 in a controlled arc having a constant bend radius by the application of a uniform bending moment across the length of the support member 30. Alternately, a controlled tensile strain may be imparted by stretching the support member 30. Alternately, support surface 32 may be elongated in a controlled manner by applying a controlled temperature change to the support member 30, so long as support member 30 has a non-zero coefficient of thermal expansion.

After support surface 32 of support member 30 is elongated by a predetermined distance (either by the application of controlled strain or the application of controlled heating/cooling), the substantially unstrained optical waveguide 10 and its associated grating 16 is securely attached along its entire length to the elongated support surface 32 of support member 30, such that no relative movement between the support surface 32 and the grating 16 is permitted (Figure 2B). The optical waveguide grating 16 is attached to the elongated support surface 32 of the support member 30 such that the longitudinal axis of the grating 16 is in alignment with the direction of the controlled elongation in the support surface 32. The optical waveguide grating 16 may be attached to the support member 30 in a variety of acceptable manners. For example, with adhesive, solder or mechanical clamping devices.

After the optical waveguide 10 and associated grating 16 are securely attached to the surface 32 of support member 30, the mechanical or thermal conditions causing elongation of the support surface 32 are removed. As support

surface 32 returns to its shorter, pre-elongated condition, a compressive axial strain (the compressive preload) indicated by arrows 40 is applied to the attached optical waveguide 10 and associated grating 16 (Figure 2C).

5 The spectral response (wavelength and/or chromatic dispersion) of the axially compressed grating 16 may subsequently be adjusted (i.e., "tuned") by application of a strain and/or temperature distribution on the support member 30 along the length of the grating 16. The application of a strain and/or temperature distribution on the support member 30 along the length of the grating 16 imparts a corresponding tensile strain in the grating 16, which alters both the index of
10 refraction of the grating 16 and the spacing of grating elements 18. The controlled application of a strain and/or temperature distribution thus allows the wavelength and/or the chromatic dispersion characteristics of the grating 16 to be adjusted to achieve a desired spectral response.

In one embodiment according to the invention, the controlled extension of
15 support surface 32 is sufficient to cause the magnitude of the compressive axial strain on the grating 16 to be equal to or greater than the previously determined maximum tensile strain required to achieve the maximum wavelength change in the grating 16.

In an alternate embodiment according to the invention, the support member
20 30 is made from a material having a coefficient of thermal expansion (CTE) different from the CTE of the optical waveguide 10 and associated grating 16. Instead of applying a controlled strain to elongate surface 32 of the support member 30 (such as by bending or stretching the support member 30 as described above), a thermal load is applied to the support member. The support member 30
25 is heated (or cooled) by the thermal load to a temperature at which the differential expansion of the support member 30 and the grating 16 (inches/inch) results in a compressive axial strain on the grating 16 when the thermal load is removed. In a preferred embodiment, the compressive axial strain is equal to or greater than the
30 wavelength change for any operating temperature of the apparatus.

Thus, in a preferred method of adjusting the spectral response of the grating 16, the compressive axial strain (the compressive preload) applied to the grating 16

prior to tuning has a magnitude equal to or greater than the magnitude of a maximum tensile strain imparted to the grating 16 during subsequent tuning operations. In this manner, during subsequent tuning, the optical waveguide 10 and grating 16 do not experience axial tension, and therefore are not subject to tensile failure.

An exemplary application of the method described above is as follows. First, assume a glass grating length of 100 mm and a round trip delay in the glass grating of 10 ps/mm (delay = 2 x speed of light x effective refractive index). Thus, the maximum delay (from the near end of the grating to the far end of the grating and back to the near end) is 1000 ps. Next, as illustrated in the graph of Figure 3, assume that the grating will be tuned around a constant center wavelength of 1554 nm, the maximum desired dispersion is 500 ps/nm, and the minimum desired dispersion is 125 ps/nm. Then, the maximum tensile strain required to tune the grating across the desired operating range is determined by the equation: Required Strain = (1-strain optic coefficient) x (wavelength shift / maximum wavelength). Thus, the Required Strain = (1 - 0.24) x 1.5/1554 = 0.07%. Therefore, a 0.07% tensile strain is applied to the support beam prior to attachment of the grating, either by simple tension or bending of the support member. After attaching the grating, the tensile strain is removed from the support member, with the result being an axially compressive force and the elimination of tension in the waveguide. This example assumes the mechanical strength of the grating is negligible relative to the strength of the support beam.

BENDING MOMENTS

Another aspect of the present invention provides an apparatus and method for adjusting the spectral response of an optical grating through the application of a pair of bending moments. The pair of bending moments cooperate to create a controlled bending moment gradient over a section of a support member to which the optical grating is attached. The apparatus and method that embodies this aspect of the invention are useful for mechanically tuning optical waveguide gratings of any length, or a selected portion of any length of optical waveguide grating. Because the apparatus and method can tune a selected portion of an optical waveguide grating, they are beneficially used for tuning a selected channel or

channels in a multi-channel grating. Specifically, they are beneficially used in a broadband wavelength division multiplexed (WDM) optical system having a plurality of optical wavelength channels.

One embodiment of an apparatus 100 for adjusting the spectral response of an optical waveguide grating is illustrated in Figure 4. The apparatus includes a broadband optical grating 116 having an operating bandwidth encompassing a plurality of channels (wavelengths). The optical waveguide grating 116 may be chirped, and may be of any suitable type of grating. For example, the grating may be a fiber Bragg grating, or a long period grating. The grating 116 is attached to a support member 130 (which is a flat beam in this illustration). A bending moment applicator 140 is configured to apply two bending moments to the support member 130. The grating 116 and support member 130 are moveable with respect to bending moment applicator 140. The bending moment applicator 140 includes a base 142 having two rotatable discs 144, 146 attached thereto. Each disc 144, 146 has two pairs of pins 150 (for a total of four pins 150 on each disc 144, 146) projecting therefrom, in a direction normal to the plane of rotation of the discs 144, 146. The support member 130 and attached grating 116 are positioned between each pair of pins 150, such that rotation of the discs 144, 146 causes one pin 150 of each pair of pins to apply a force to the support member 130. A thumbwheel 160 and worm gear 162 are associated with each disc 144, 146. As either of the thumbwheels 160 are rotated, the worm gear 162 causes the associated disc 144, 146 to rotate. As the discs 144, 146 rotates, forces are applied to the support member 130 via pins 150, thereby creating a bending moment gradient in support member 130 between the discs 144, 146. In the embodiment illustrated in Figure 4, both the right and left discs 144, 146, respectively, have been rotated clockwise. In this case, the grating 116 sees a linear strain gradient between the discs 144, 146. The maximum axial compression on the grating 116 is adjacent to the downward pushing right pin of the left disc 144 and the maximum tension is adjacent to the upward pushing left pin on the right disc 146. Although eight pins 150 are shown on the two discs, it should be noted that at any point in time only four of the pins 150 are applying force to the beam 130.

In one embodiment according to the invention, the bending moment applicator 140 is configured to apply the two bending moments to the support member 130 separated by a distance less than the length of the optical grating 116. The distance separating the application points of the bending moments may be selected so that only a single channel of the plurality of channels, or a subset of the plurality of channels, in the optical grating 116 are tuned. In this embodiment, the bending moment applicator 140 is preferably moveable with respect to the support member 130 and optical grating 116, such that the application points of each of the bending moments can be independently adjusted to tune the spectral response of any desired channel(s) of the broadband optical grating 116.

In another embodiment according to the invention, the bending moment applicator 140 is configured to apply the two bending moments to the support member separated by a distance equal to or greater than the length of the optical grating 116. In this configuration, the bending moments can be adjusted to tune the spectral response of the entire grating 116.

Embodiments of the invention may employ axial pre-compression of the optical grating in addition to the application of a pair of bending moments to the support member. As described above, the optical grating 116 may be attached to the support member 130 such that the support member 130 axially compresses the optical grating 116. Preferably, the compressive axial strain (the compressive preload) applied to the optical grating 116 has a magnitude equal to or greater than the magnitude of a maximum tensile strain imparted to the grating during subsequent tuning operations using the application of a pair of bending moments.

Figure 5 illustrates another embodiment of an apparatus 200 for adjusting the spectral response of an optical waveguide grating. In the apparatus 200 of Figure 5, the relationship between the two bending moments is fixed so that the dispersion of an optical waveguide grating 216 is changed, but not the center wavelength. The apparatus of Figure 5 includes the grating 216 attached to a flat beam support member 230. The optical grating 216 and support member 230 are moveable with respect a bending moment applicator 240. The bending moment applicator 240 includes a housing 242 having guide members (pins 244 in the illustrated embodiment) adjacent both sides of the housing 242. The support

member 230 and attached grating 216 extend across the housing 242 and are positioned between the guide members 244. To apply a moment to the grating 216, a thumbwheel 250 turns a lead screw 252, which in turn moves a cam 260 to the left or right of its normal centered location in the housing 242. The cam's
5 angled cam surfaces 262 contact a movable central part 264 which rotates about a pivot point 266. Pins 270 mounted symmetrically about the pivot point 266 provide bending forces to the flat support beam 230. In one embodiment, a portion of the cam 260 is exposed through the top surface 276 of the housing 242, so that the position of the cam 260 relative to the housing 242 can be used to determine
10 the current tuning amount.

Figure 6 illustrates apparatus 200 of Figure 5 slidably mounted on rails 302 of an assembly 300. Assembly 300 includes a long grating 316 on a support beam 330. In use, the apparatus 200 is moved to a position centered over a selected center wavelength of the grating 316. The apparatus 200 is then secured in
15 position on rails 302 of assembly 300 and the chromatic dispersion immediately around the selected center wavelength is adjusted using the thumbwheel 250.

Figure 7 illustrates a test jig 400 for applying bending moments to a supporting beam 430. Test jig 400 includes guide pins 450 mounted on stationary base 451, and a rotating disk 452 mounted on base 451. Rotating disk 452 includes
20 pins 453, 454, 455, 456 to apply bending moments to beam 430 and the grating 416 thereon. The bending moments created by the test jig 400 create strain profiles identical to the apparatus 200 of Figure 5.

Figure 8 illustrates the chromatic dispersion tuning of a Bragg grating written at 430 ps/nm and adjusted using the test jig 400 shown in Figure 7. The six
25 lines represent six different magnitudes of force applied to the end of the tuning rod 440. As can be seen, the dispersion (slope of the delay curves) around the central wavelength is effectively adjusted using this method. In this example, the chromatic dispersion was adjusted down to a minimum of 130 ps/nm, and up to a maximum of 1040 ps/nm. In the variously described embodiments according to
30 the invention, the support member 130, 230, 330 may optionally be formed of a material having a coefficient of thermal expansion (CTE) below approximately 5 ppm/C°. A low CTE minimizes changes in the spectral response of a grating due

to thermal conditions, and is desirable where the device is not intended to be thermally responsive. For example, the support member 130 may be formed of graphite, a graphite composite material, Invar or Kovar, to name a few materials.

Although the support members 130, 230, 330 described so far have
5 symmetric cross-sections, the support member may alternately be asymmetric about its neutral axis. For example, a support member 530 illustrated in Figure 9 is asymmetric about its neutral axis 532. The optical grating 536 is attached to the asymmetric support member 530 at a region most distant from the neutral axis 532. As used herein, the neutral axis is the line or plane in a support member under
10 transverse pressure, at which the support member is neither stretched nor compressed (i.e., where the longitudinal stress is zero). Depending upon the shape (cross-section) of the support member, the neutral axis may be, but is not necessarily, colinear with the centroidal axis. As used herein, the centroidal axis connects the centroids of the cross sections of the support member. The support
15 member is said to be straight or curved in accordance with the shape of its centroidal axis. An asymmetric support member shape as shown in Figure 9 has the grating 536 placed at a relatively large distance from the neutral axis 532, as compared to the size of grating 536. When a vertical bending moment is applied, this large distance provides a larger ratio of strain per unit bending moment than
20 symmetric support member designs. The asymmetric support member shape also results in a lower average strain on the support member material than a symmetric support member shape.

A method of tuning the spectral response of an optical grating or section thereof according to the invention is illustrated in Figure 10. First, the optical
25 grating is attached to support member (step 500). The grating may optionally be attached to the support member such that the support member axially compresses the grating, as described above. The grating is attached to the support member along its length, typically parallel to and spaced from a centroidal axis 552 of the support member. The support member preferably has a uniform cross-section
30 along the length of the optical grating.

Next, a portion of the grating that will have its spectral response adjusted or “tuned” is selected (step 502). Typically, the selected portion of the grating will be

centered about a single channel or wavelength to be adjusted. However, the selected portion may encompass a plurality of channels, and may include the entire length of the grating.

The support member is next deformed by applying a pair of bending
5 moments (operating on the support member) at some distance from each other (step 504). The location of the bending moments is selected such that one bending moment is applied adjacent to one end of the adjusted region and the other bending moment is applied adjacent the other end of the adjusted region. Application of the bending moments on the support member creates an axial strain profile along the
10 length of grating and thereby altering the spectral response of the grating within the adjusted region.

As the bending moments are applied, the spectral response of the grating can be monitored. The magnitude and location of one or more of the bending moments can then be adjusted independently and dynamically to tune the spectral
15 response of the optical grating until a desired spectral response is achieved (step 506).

For example, assume the objective is to tune a uniformly chirped grating to provide -1300 ps/nm dispersion in the 1 nm band from 1550 nm to 1551 nm. The two bending moments could be spaced apart by a distance of approximately
20 130 mm. The moment at one end of the band would then be adjusted to result in the grating located at that position reflecting the 1551 nm wavelength and the moment at the other end of the band would then be adjusted so that the grating would reflect the 1550 nm wavelength at that position. That is, the wavelength is set at each of two points in the grating, with the result being a defined channel
25 width and dispersion. In actual practice, the tuned band would typically include a safety margin and be somewhat larger and than the band of the optical signal.

Various combinations of bending moments and the resulting change in the spectral response of the grating are illustrated in Figures 11-13. In each of Figures 11-13, the "original" spectral response is shown as solid line "A", while the
30 "adjusted" spectral response is shown as dashed line "B". Depending upon how the bending moments are applied, altering the spectral response of the optical grating may include uniformly shifting spectral response (i.e., center wavelength

and chromatic dispersion) of the grating (Figure 11), altering the chromatic dispersion of the grating (Figure 12), or shifting the center wavelength and also altering the chromatic dispersion of the optical grating (Figure 13).

In each of the illustrated examples, a chirped grating is attached to the top surface of a support beam, the short wavelength end of the grating is to the left side of the diagram and light is launched into the grating from the right side of the diagram. In each case the delay vs. wavelength chart represents only the length of grating between the innermost force application points.

Figure 11 illustrates uniformly shifting the spectral response of the grating. Specifically, the center wavelength and dispersion of the grating has shifted as a result of four equal forces creating equal and opposite moments near the ends the support beam.

Figure 12 illustrates altering or tuning the chromatic dispersion of the grating. The four forces are configured so that the moment created by the inside forces is equal and opposite to the moment created by the outside forces. This results in a uniform moment gradient between the inner two force application points and results in a change in the chromatic dispersion of the grating, while the center wavelength stays the same.

Figure 13 illustrates a combination of wavelength shift and chromatic dispersion tuning achieved by superimposing the examples of Figures 10 and 11. In this superposition of forces, the clockwise and counterclockwise moments at the right end of the beam tend to cancel resulting in only a small upward force. The magnitude and direction of the bending moment at each location along the grating are proportional to the wavelength shift at that location.

As noted above, the "two-moment" apparatus and method disclosed herein can be used to tune the spectral response of an optical waveguide grating over any portion of the grating, including the full length of a grating. However, for a long grating, the change in spectral response per unit strain would be small. Achieving a meaningful or useful change in the spectral response would require a large strain on the fiber. In many applications, it is beneficial to tune a single channel within a multi-channel grating or independently tune two or more different channels within a long multi channel grating. This objective can be easily achieved using the

apparatus and method disclosed herein, because adjusting the spectral response of only a portion of a grating requires a lower average/peak strain than needed to tune the full length of the grating.

BEND AND ROTATE

5 Another aspect of the present invention provides an apparatus and method for adjusting the spectral response of an optical grating by attaching the grating to a longitudinal support member, applying a bending moment to the support member to create a bend or curve in the support member, and then rotating the support member about its (curved) centroidal axis. As the support member is rotated,
10 depending upon its initial position on support member, the grating moves from an area of tension on the outside of the support member bend to an area of compression on the inside of the support member bend (thus reflecting a shorter wavelength), or alternately move from the inside of the support member bend outward (and thus reflecting longer wavelengths).

15 One exemplary embodiment of an apparatus for adjusting the spectral response of an optical waveguide grating according to the invention is illustrated in Figure 14. A strain-imparting support member 550 (in this exemplary embodiment a longitudinal rod having a circular cross-section) is configured for simultaneous longitudinal bending and rotating about its centroidal axis 552. A longitudinal
20 optical waveguide 554 containing a grating 556 is attached along its entire length to the strain-imparting support member 550. In one embodiment according to the invention, the grating 556 is a long optical grating, and has a length of at least 100 mm.

 The support member 550 is operatively coupled to a mechanism (not
25 shown) for bending and rotating the support member. The mechanism applies a bending moment 560 to the support member 550 for longitudinally bending the support member. The support member 550 is then rotated (as indicated by arrow 562) about its now curved or bent centroidal axis 552 to adjust the center wavelength of the grating 556.

30 In one embodiment according to the invention, the support member 550 bends and/or rotates as a function of temperature, such that the apparatus is suitable for use as a thermal compensation package. The thermally responsive

bending and/or rotating may be accomplished by selecting the material of the support member 550 to be responsive to temperature changes, or by configuring the mechanism for bending and rotating to be responsive to temperature changes, or a combination of both.

5 The grating 556 and associated waveguide 554 may be attached to the support member 550 in several different orientations. In one embodiment according to the invention, as illustrated in Figure 14, the longitudinal axis of the grating 556 is parallel to the centroidal axis 552 of the support member 550. In this orientation, the mechanism for bending and rotating the support member 550
10 about its centroidal axis 552 tunes the wavelength of the optical grating 556 by controlling the longitudinal bending and rotating of the strain-imparting support member in accordance with the equation:

$$\lambda = \lambda_0 [1 + (1 - P) r \cos(\theta) / R]$$

Where:

15 λ_0 = unstrained wavelength of the grating;
 P = the strain optic coefficient of the grating;
 R = radius of the bend in the support member;
 r = radial distance from the centroidal axis to the core of the grating; and
 θ = angle of rotation about the centroidal axis (as shown in Figure 15).

20 In another embodiment according to the invention, as illustrated in Figure 16, the support member 550 has a cavity 570 extending longitudinally therethrough. The grating 556 is positioned within the cavity 570 in the support member. In the embodiment of Figure 16, the cavity 570 extending through the support member 550 is parallel to the centroidal axis 552 of the support member.
25 In that instance, the mechanism for longitudinally bending and rotating the tubular support member 550 about its centroidal axis 552 tunes the wavelength of the optical grating 556 by controlling the longitudinal bending and rotating of the support member in accordance with the equation provided above.

 In another embodiment according to the invention, as illustrated in Figure
30 17, the support member 550 has a cavity 570' extending longitudinally therethrough that intersects the centroidal axis 552 of the support member, or is not parallel to the centroidal axis 552 of the support member. Support member 550 is

shown in an unbent condition, so that the relationship between cavity 570' and centroidal axis 552 may be clearly seen. The longitudinal axis of the grating 556 is positioned within the longitudinal cavity 570' in the support member. Because the longitudinal cavity 570' of the support member 550 is no longer parallel to the centroidal axis 552 of the support member, the result of bending and rotating support member 550 is not a simple wavelength shift in the spectral response of the grating. The mechanism for longitudinally bending and rotating the support member about its centroidal axis 552 tunes the wavelength of the optical grating 556 by controlling the longitudinal bending and rotating of the support member in accordance with the equation provided above. However, the value of r is equal to the distance between the centroidal axis 552 of the support member 550 and the grating 556, and changes as a function of location along the grating 556. In the case shown where the grating crosses the centroidal axis of the support member, subsequent bending and rotation does not change the wavelength at the crossing point, but changes the dispersion over the length of the grating.

In another embodiment according to the invention, the longitudinal axis of the grating 556 is wound about the centroidal axis 552 of the support member 550. In the exemplary embodiment of Figure 18A, an optical waveguide 554 having an optical grating 556 is helically wound about the centroidal axis 552 of a longitudinal support member 550 having a circular cross-section. In this orientation between grating 556 and centroidal axis 552, the result of bending and rotating support member 550 is not a simple wavelength shift. Instead, when the support member 550 is bent, some sections of the grating 556 are placed in tension (on the "outside" of the bend) and other areas of the grating 556 are placed in compression (on the "inside" of the bend). The spectral response is thus modulated in a manner that correlates to the helix angle (α) of the grating 556 as it winds around support member 550. The mechanism for bending and rotating the support member 550 about its centroidal axis 552 tunes the wavelength of the optical grating 556 by controlling the longitudinal bending and rotating of the strain-imparting support member in accordance with the equation provided above. However, the angle of rotation (θ) becomes a function of location on the grating 556 and will therefore vary for each point along the grating.

As an example, assume that the unstrained grating 556 of Figure 18A has a uniform dispersion (i.e., the delay slope is constant) before the support member 550 is bent. Then, it can be seen in the graph of Figure 19A that bending the support member 550 results in a modulation around the initial (unstrained) delay line. Since dispersion is defined as the slope of the delay line, it is clear that the dispersion changes as a function of the position in the grating 556. The graph of Figure 19B shows the dispersion of the grating 556 as a function of wavelength and relates to the strain distribution used to generate the graph of Figure 19A. By rotating the support member 550 without changing the radius of the bend, the dispersion at any wavelength will vary between the extremes shown in Figure 19B. Thus a single wavelength or narrow band within the bandwidth of the grating 556 may readily have its dispersion adjusted. This embodiment thus provides the ability to tune only a selected section of a grating 556.

To avoid the creation of etalons in an optical waveguide grating (as is typically preferred in a grating-based dispersion compensation filter), the intrinsic chirp of the grating should be greater than the strain induced chirp caused by bending of the support member. This can be achieved by assuring that the following relationship is maintained:

$$\text{Intrinsic Chirp} > \lambda_o * (1 - P) * \sin(\alpha) / R$$

Where:

λ_o = unstrained wavelength of the grating;

P = the strain optic coefficient of the grating;

α = the helix angle (the angle between the fiber grating and the axis of the support member); and

R = radius of the bend in the support member.

For example, assume a grating written with a dispersion of 500 ps/nm has an intrinsic chirp of about 20 nm of wavelength shift per meter of grating length (intrinsic chirp = 20 nm/m). Further assume a maximum wavelength of approximately 1600 nm ($\lambda_o = 1600$ nm). The strain optic coefficient of a silica fiber is approximately 0.24 (P = 0.24). If one desires to bend the support member in an arc having a radius of 2 meters (R = 2 m), then using the relationship given above, the helix angle α should not exceed about 1.8 degrees.

If the bend in the support member has a larger radius, a larger helix angle may be used. For example, using the same grating as in the example above, and a bend radius of 5 meters, the helix angle should not exceed about 4.6 degrees.

The effect of the bend radius R on delay and dispersion is illustrated in
5 Figures 19C and 19D for a grating helically wrapped about a support member. The plots of Figures 19C and 19D model an optical waveguide grating having a dispersion of 500 ps/nm and an intrinsic chirp of about 20 nm of wavelength shift per meter of grating length (intrinsic chirp = 20 nm/m) helically wrapped around a support rod having a radius of 7 mm. The grating is wrapped with a helix angle α
10 of 2 degrees. The strain optic coefficient of the grating is approximately 0.24 ($P = 0.24$). The support member is variously bent in an arc having a radius R of 5 meters (curve S1), 10 meters (curve S2), and 20 meters (curve S3).

In the exemplary embodiment of Figure 18A, a single optical waveguide grating 556 is wound about the centroidal axis 552 of the support member 550.
15 The slope of the dispersion curve of the grating 516 (as illustrated in Figure 19B) can be seen to vary continuously between the extremes, such that there is no region where the slope of the dispersion curve is relatively constant. As a result, for a given rotation of the support member about its centroidal axis, at some points in the grating (i.e., where the slope of the dispersion curve is small) only a small
20 change in dispersion will result, while at other points in the grating (i.e., where the slope of the dispersion curve is large) a large change in dispersion will result. In some applications, it is desirable that the slope of the dispersion curve be relatively constant, so that for a given rotation of the support member about its centroidal axis, the change in dispersion is approximately the same for all points along the
25 grating.

In an embodiment illustrated in Figure 18B, two identical optical waveguide gratings 516, 516' are wound about the support member 550. Gratings 516, 516' are helically wrapped in a similar manner, with the gratings 516, 516' mounted on the support rod 180 degrees apart. The optical signal for grating 516
30 is launched into the short wavelength end (right) and the optical signal is launched into grating 516' using the long wavelength end (left), such that their dispersion curves are of opposite signs and 180° apart. As illustrated in Figure 19E, summing

the dispersion curves of individual gratings 516, 516' provides a dispersion curve having a relatively constant slope. Advantageously for some applications, the dispersion curve resulting from the summed individual dispersion curves crosses the zero axis, such that the apparatus may be used to provide either positive or
5 negative dispersion, as needed.

As discussed above and as shown in Figures 14-18B, the grating 556 may be attached to the support member 550 such that the longitudinal axis of the grating 556 has several different possible orientations with respect to the centroidal axis 552 of the support member. Tuning of the grating 556 is controlled in
10 accordance with the equations provided above.

In another method for adjusting the spectral response of an optical grating 556 according to the invention, a generally unstrained grating 556 is attached to an already strained (i.e., bent or flexed) support member 550. The grating 556 is attached to the section of the support member having the greatest tension (e.g., the
15 outside of the bend). As the support member 550 is rotated about its centroidal axis 552, the grating 556 moves from its original unstrained position on the outside of the support member 550 bend to a position where it sees a compressive strain as it moves toward the inside of the support member bend. The grating 556 is thus
tuned using axial strain only, and no tensile strain is placed on the grating 556.

The support member 550 has so far been described herein as having a
20 circular cross-section. However, other cross-sectional profiles of support member 550 may also be implemented. For example, support member 550 may have an elliptical cross-section or any other non-circular cross-section. Additionally, the cross-section of support member 550 may vary along the length of support member
25 550.

The mechanism for longitudinally bending and rotating the support member and attached grating 556 about the centroidal axis 552 may comprise any suitable device that provides controlled bending and rotating of the support member. One such mechanism 600 is illustrated in Figures 20A and 20B, in which a positioning
30 plate 602 includes at least one set of positioning grooves 604. Grooves 604 are sized to receive support member 550, and are oriented to maintain a predetermined bend radius in support member 550. Multiple sets of grooves (for example,

grooves 604', 604''') corresponding to different bend radii may additionally be provided so that support member 550 can be bent across a range of predetermined bend radii. Support member 550 may be rotated about its centroidal axis 552 by, for example, rotating support member by hand, or by operably coupling support member 550 to a drive motor 608. Drive motor 608 may be manually controlled, or alternately controlled by controller 610 to automatically rotate support member 550 and thereby adjust the spectral response of grating 556.

Another mechanism 620 for longitudinally bending and rotating the support member 550 and attached grating 556 about the centroidal axis 552 is illustrated in Figure 21. Support member 550 is held adjacent its ends in ferrules 622, Ferrules 622 are pivotable with respect to base member 624 (as indicated by arrows 626), and are configured such that the distance between ferrules 622 may be altered (as indicated by arrows 627), thereby changing the bend radius of support member 550. For example, ferrules 622 may be moved between fixed, incremental positions in base member 624. Alternately, the distance between ferrules 622 may be continuously adjusted, such as by attaching one or both of ferrules 622 to a drive mechanism 628, such as a screw drive, that moves ferrules 622 closer together or further apart as necessary to change the bend radius of support member 550. Drive mechanism 628 may be operated and controlled manually, or alternately controlled by a drive motor 630 and controller 632. Support member 550 may be rotated about its centroidal axis 552 by, for example, rotating support member within ferrules 622 by hand, or by operably coupling support member 550 to a drive motor 634. Drive motor 634 may be manually controlled, or alternately controlled by controller 632 to automatically rotate support member 550 and thereby adjust the spectral response of grating 556.

The above-described embodiments according to the invention provide simple and cost effective ways to adjust (i.e., "tune") the wavelength and/or chromatic dispersion characteristics (i.e., the "spectral response") of an optical waveguide grating, such as a fiber Bragg grating or long period grating. The various embodiments require a small number of relatively simple parts, as compared to the devices and methods previously available. The various embodiments according to the invention provide an apparatus and method for

achieving a dispersion compensation apparatus having high reliability by using a combination of beam bending and compressive preload on the optical grating to reduce strain in the grating. Reduced strain in the grating permits a wider bandwidth and tuning range.

5 Although specific embodiments have been illustrated and described herein for purposes of description of the preferred embodiment, it will be appreciated by those of ordinary skill in the art that a wide variety of alternate and/or equivalent implementations calculated to achieve the same purposes may be substituted for the specific embodiments shown and described without departing from the scope
10 of the present invention. Those with skill in the optical, mechanical, and opto-mechanical arts will readily appreciate that the present invention may be implemented in a very wide variety of embodiments. This application is intended to cover any adaptations or variations of the preferred embodiments discussed herein. Therefore, it is manifestly intended that this invention be limited only by
15 the claims and the equivalents thereof.

WHAT IS CLAIMED IS:

1. A method of adjusting the spectral response of an optical grating, the method comprising:
 - attaching an optical grating to a support member, wherein the optical grating has a length extending between a first end of the optical grating and a second end of the optical grating and wherein the optical grating is spaced from a centroidal axis of the support member; and
 - applying bending moments at two or more locations on the support member to bend the optical grating in at least a transverse direction to create an axial strain profile along the length of optical grating and thereby altering the spectral response of the optical grating.
2. The method of claim 1, wherein the optical grating comprises an optical grating selected from the group consisting essentially of: fiber Bragg gratings and long period gratings.
3. The method of claim 1, wherein attaching the optical grating to a support member comprises attaching the grating along the entire length of the grating.
4. The method of claim 1, wherein attaching an optical grating to a support member comprises attaching a grating having a length of 100 mm or greater.
5. The method of claim 1, wherein altering the spectral response of the optical grating comprises at least one of uniformly shifting the spectral response of the optical grating, altering the chromatic dispersion of the optical grating, and changing the bandwidth of the optical grating.
6. The method of claim 1 wherein applying bending moments at two or more locations on the support member comprises applying at least one bending moment at a location positioned between the first and second ends of the optical grating.
7. The method of claim 1, wherein where the support member is asymmetric about its neutral axis, and wherein attaching the optical grating to the support

member comprises attaching the optical grating to a support member region most distant from the neutral axis.

8. The method of claim 1, wherein applying bending moments to alter the spectral response of the optical grating comprising adjusting at least one of a location of at least one bending moment and a magnitude of at least one bending moment to alter the spectral response of the optical grating.
9. The method of claim 1, further comprising:
rotating the bent support member about the centroidal axis and thereby altering the spectral response of the optical grating.
10. 10. The method of claim 9, further comprising aligning a longitudinal axis of the optical waveguide grating parallel to the centroidal axis of the longitudinal support member.
11. The method of claim 9, further comprising winding the optical waveguide grating around the centroidal axis of the support member.
- 15 12. The method of claim 1, further comprising axially compressing the optical grating prior to bending the support member.
13. The method of claim 12, wherein axially compressing the optical grating prior to bending the support member comprises:
imparting a controlled extension to a surface of the support member;
attaching the optical grating to the extended surface of the support member such that a longitudinal axis of the grating is in alignment with the direction of the controlled extension; and
removing the controlled extension from the support member to create a compressive axial strain on the grating.
- 25 14. The method of claim 13, wherein imparting a controlled extension comprises at least one of stretching the support member, and applying a controlled

temperature change to the support member where the support member and optical grating have different coefficients of thermal.

15. An apparatus for adjusting the spectral response of an optical grating in an optical waveguide, the apparatus comprising:
- 5 a support member having a centroidal axis;
a longitudinal optical waveguide grating attached to the support member;
and
a mechanism for applying at least two bending moments to the grating support member to bend the optical grating in at least a transverse direction,
10 whereby the spectral response of the grating is adjusted by altering the bending moments.
16. The apparatus of claim 15, further comprising a mechanism for rotating the support member about the centroidal axis, whereby the spectral response of the grating is adjusted by rotating the support member.
- 15 17. The apparatus of claim 16, wherein the support member is configured for simultaneous longitudinal bending and rotating about the centroidal axis.
18. The apparatus of claim 15, wherein a longitudinal axis of the optical waveguide grating is parallel to the centroidal axis of the support member.
19. The apparatus of claim 15, wherein the optical waveguide grating is wound
20 about the centroidal axis of the support member.
20. The apparatus of claim 15, wherein the optical waveguide grating is attached to the support member along the entire length of the grating.

1/16

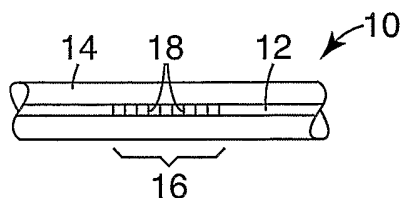

Fig. 1

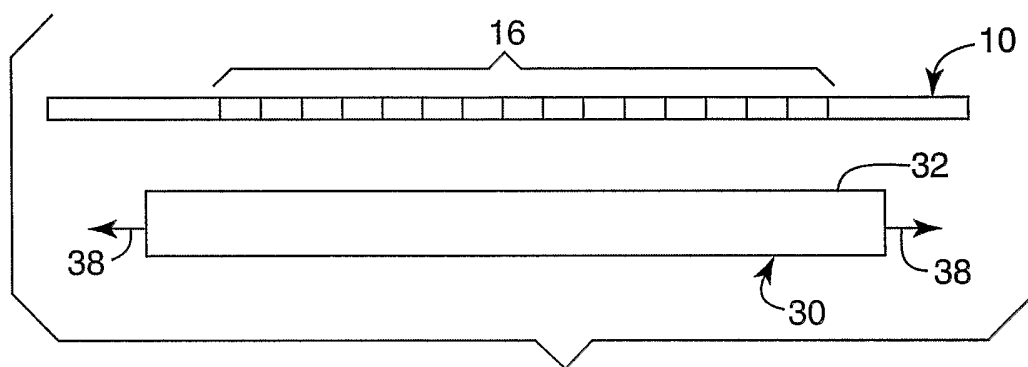

Fig. 2A

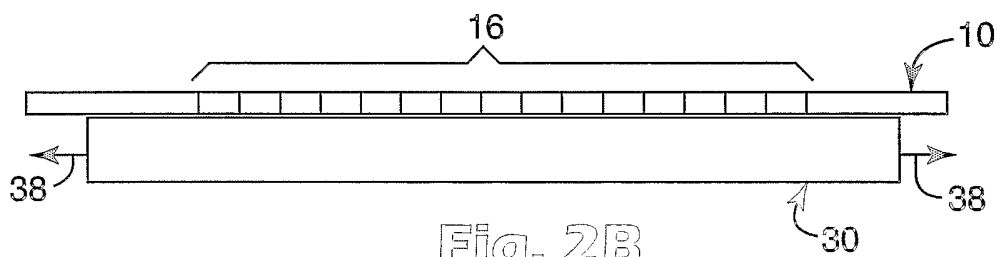

Fig. 2B

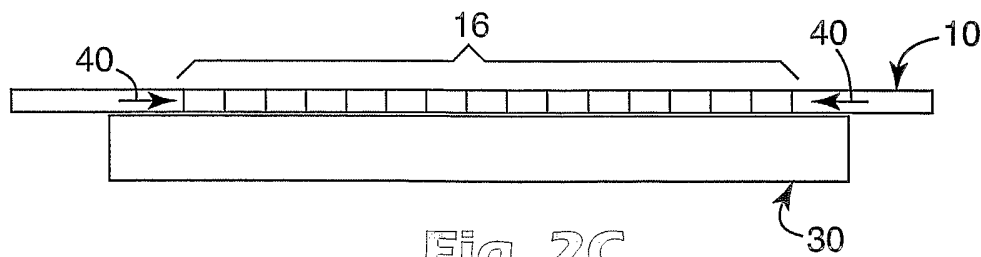

Fig. 2C

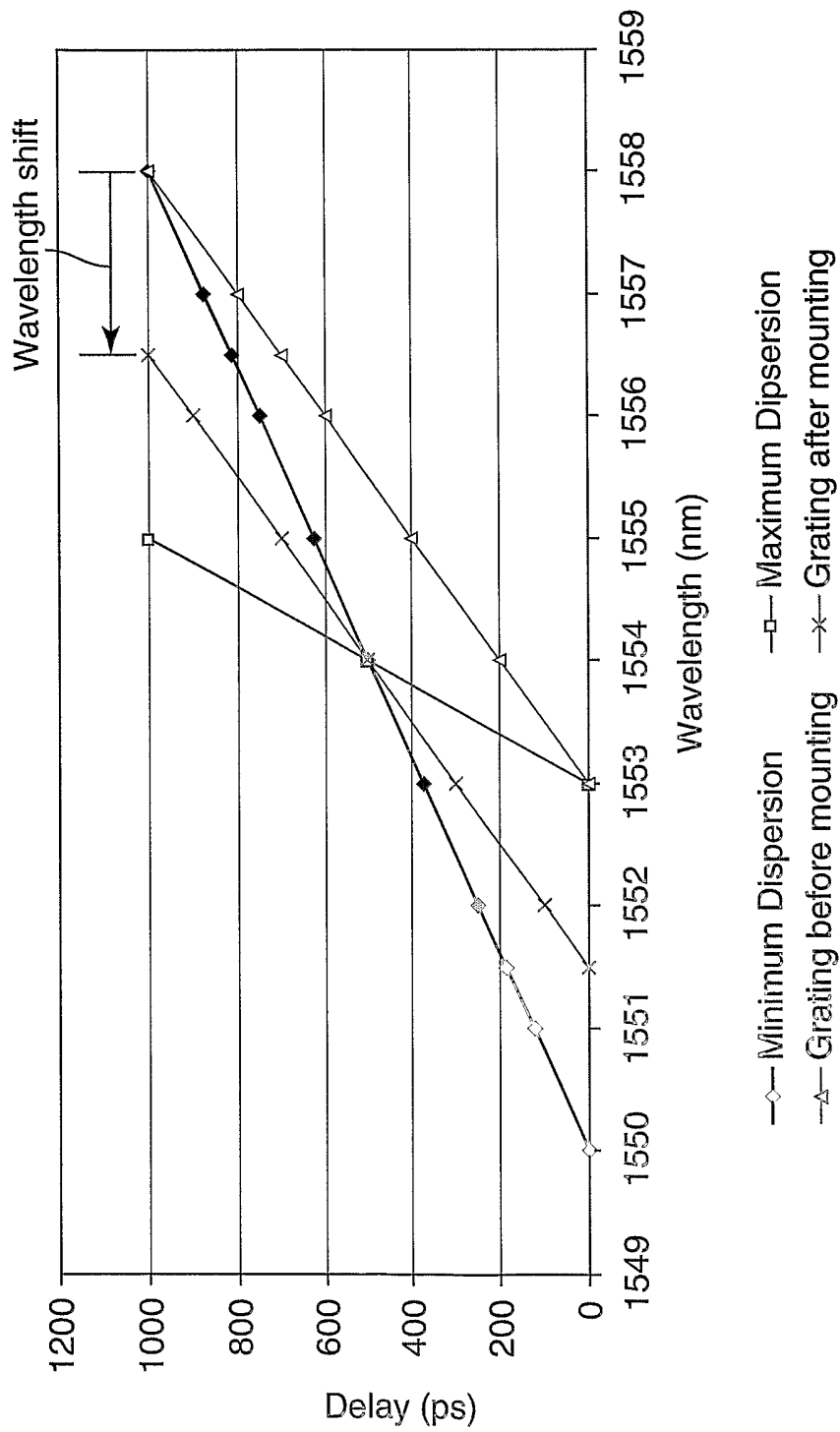

Fig. 3

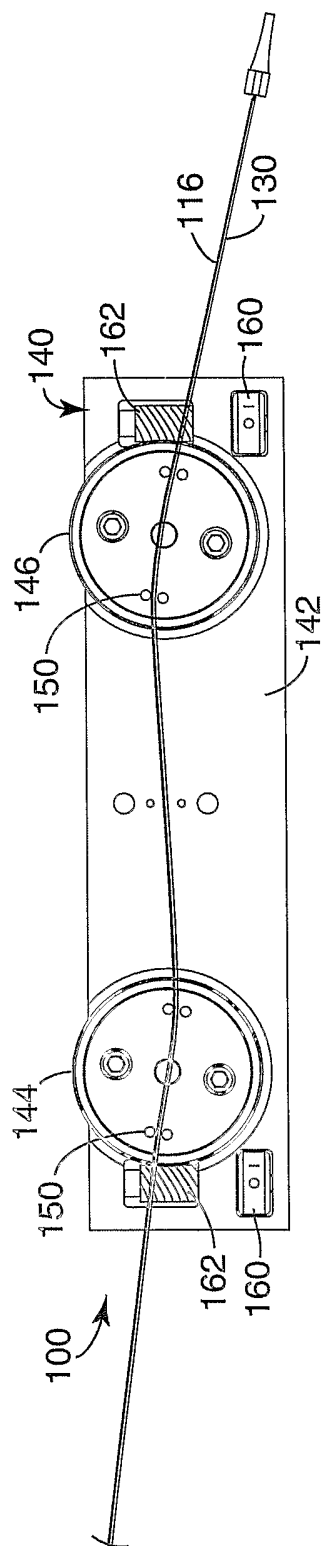

Fig. 4

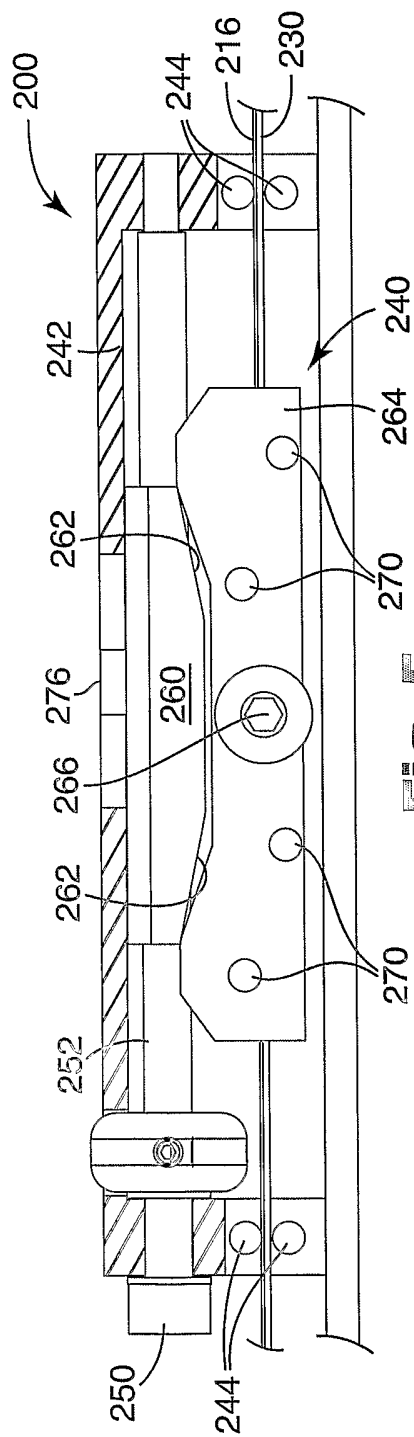

Fig. 5

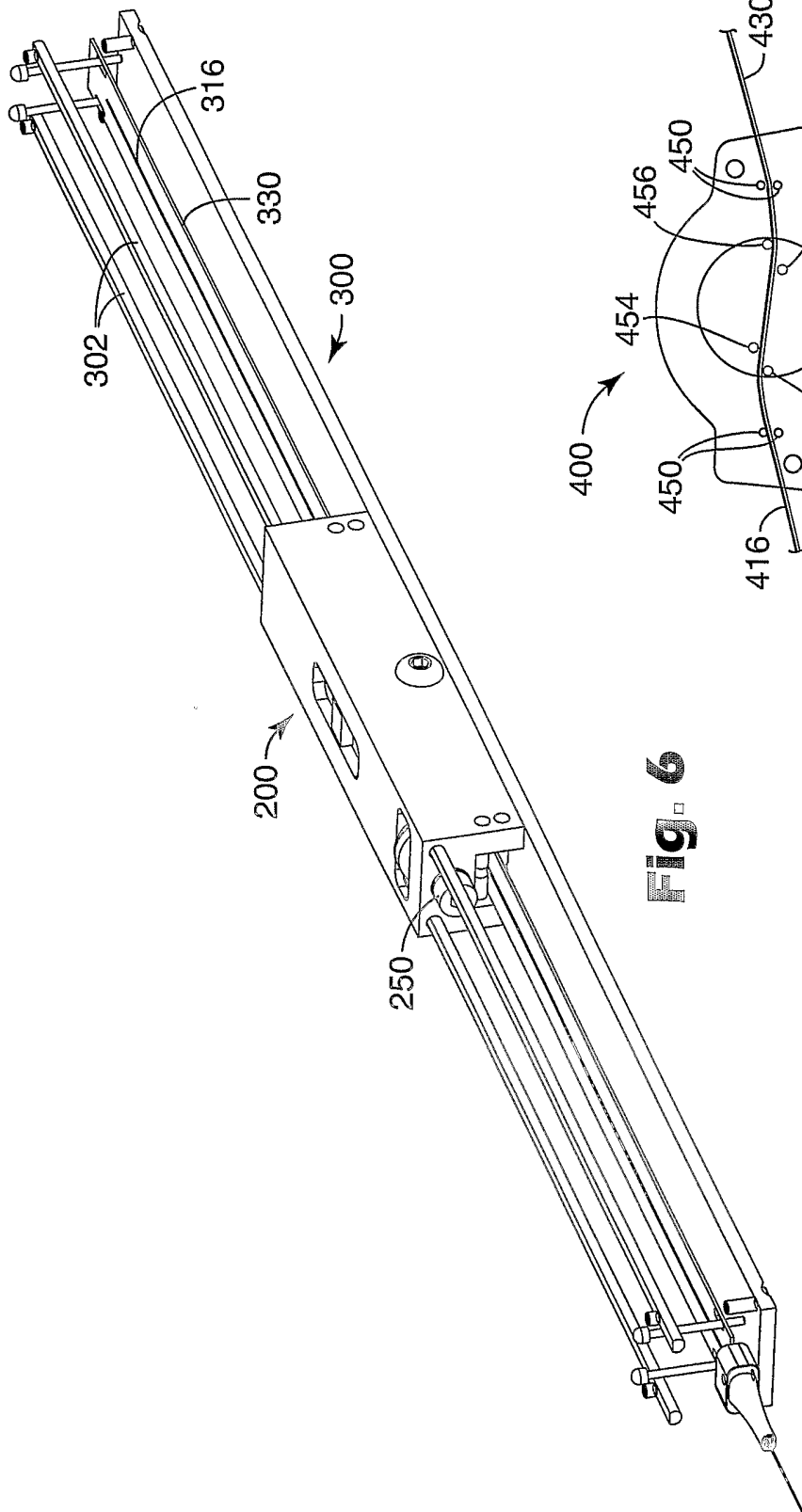

Fig. 6

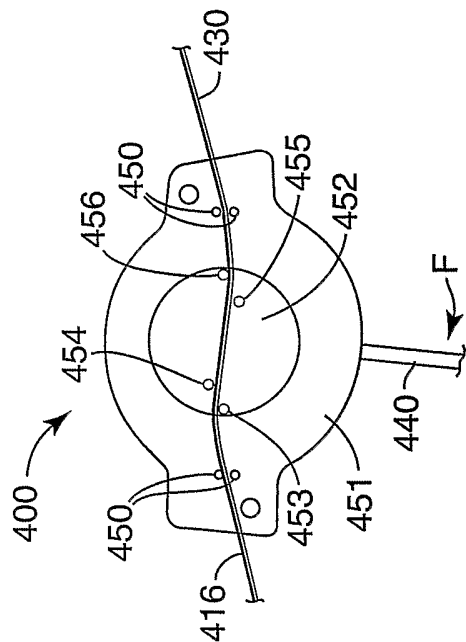

Fig. 7

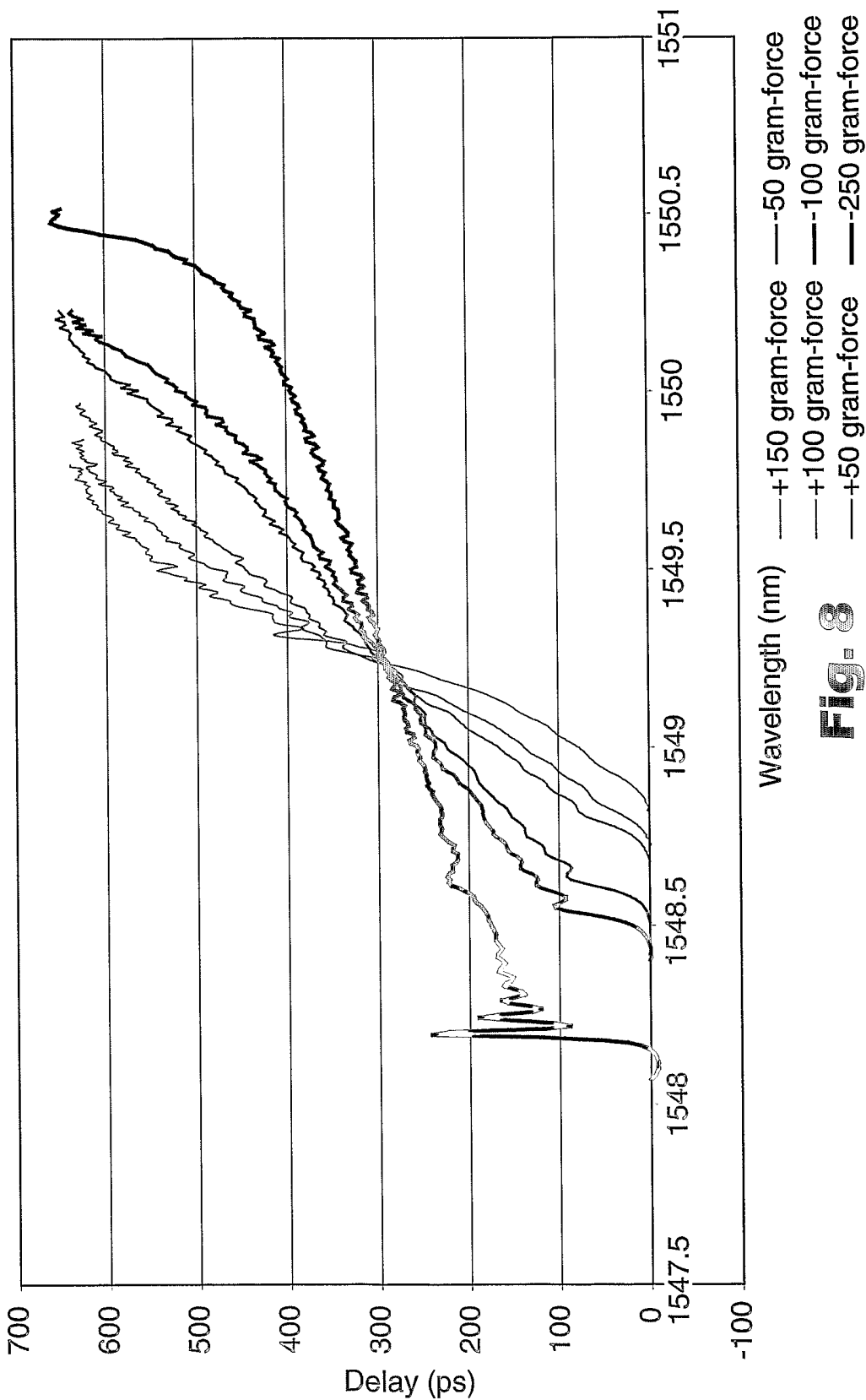

Fig. 8

6/16

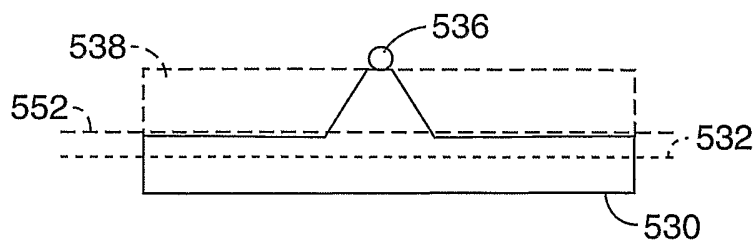

Fig. 9

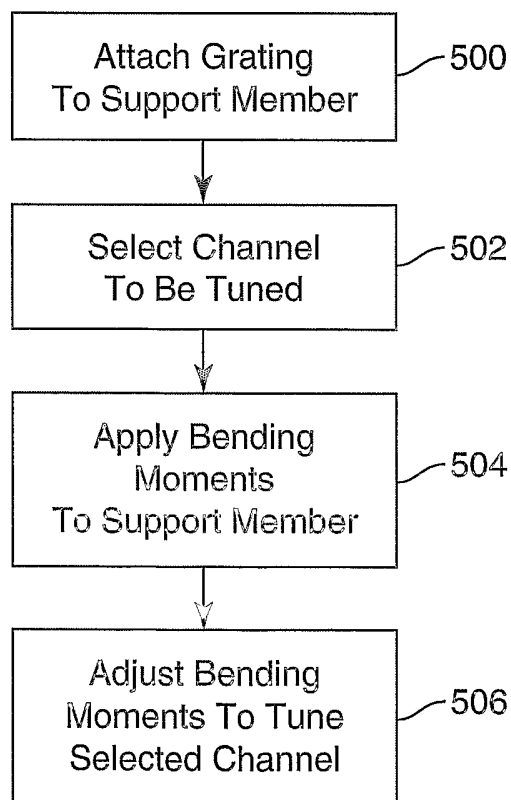

Fig. 10

7/16

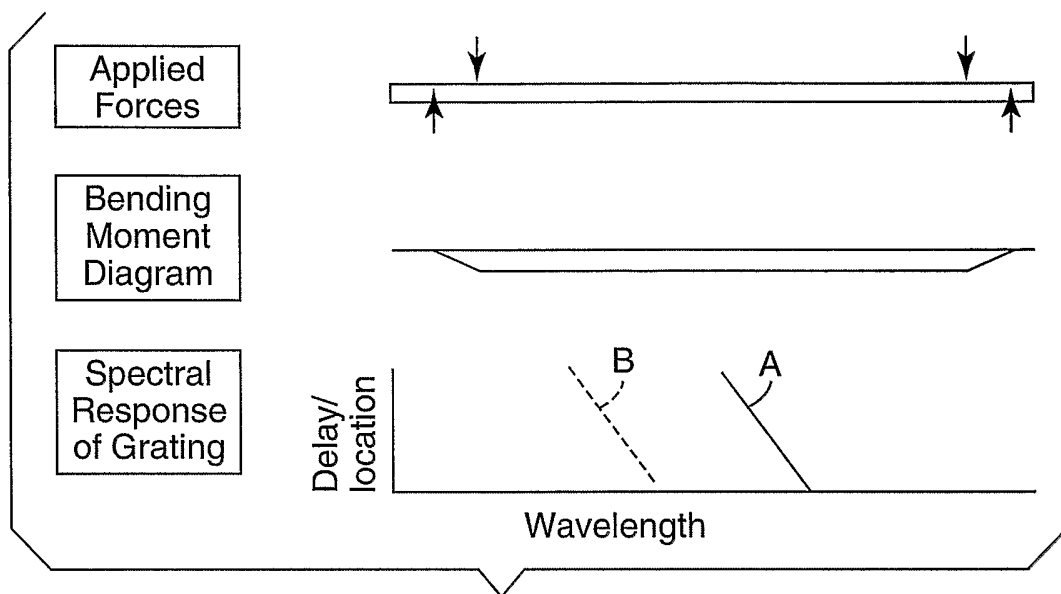

Fig. 11

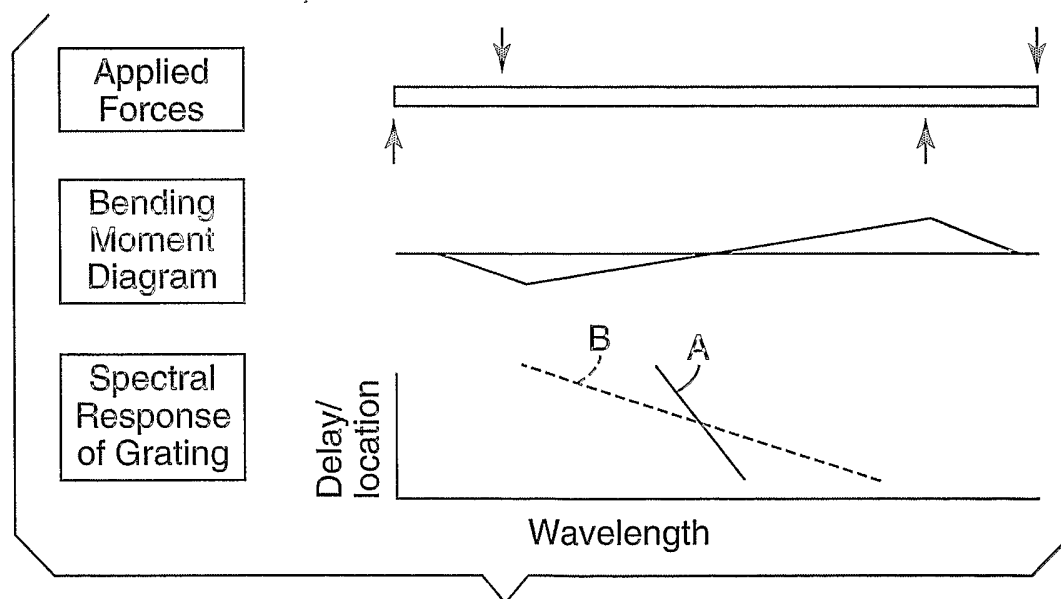

Fig. 12

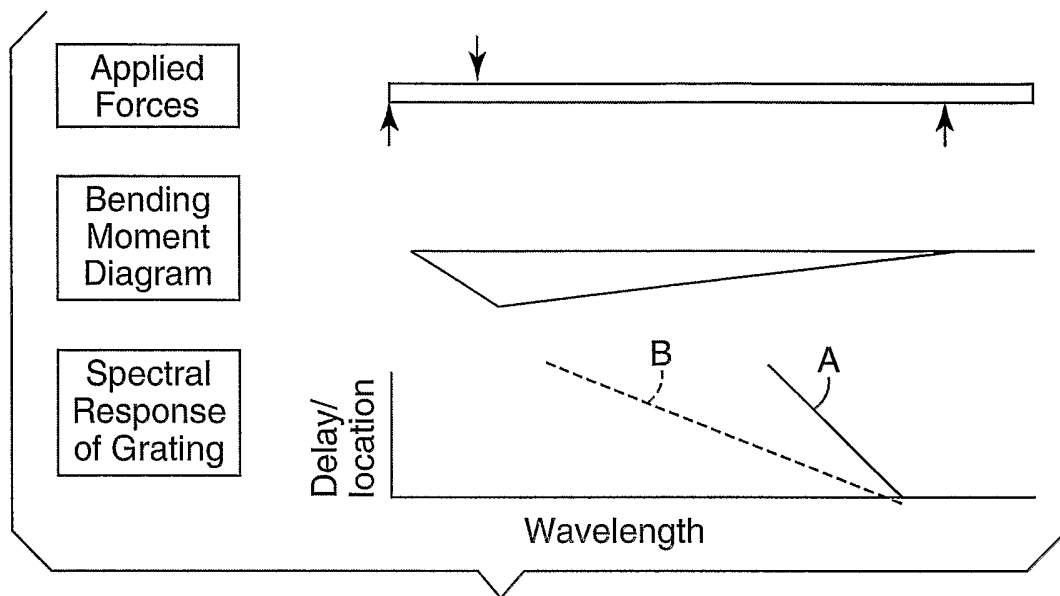

Fig. 13

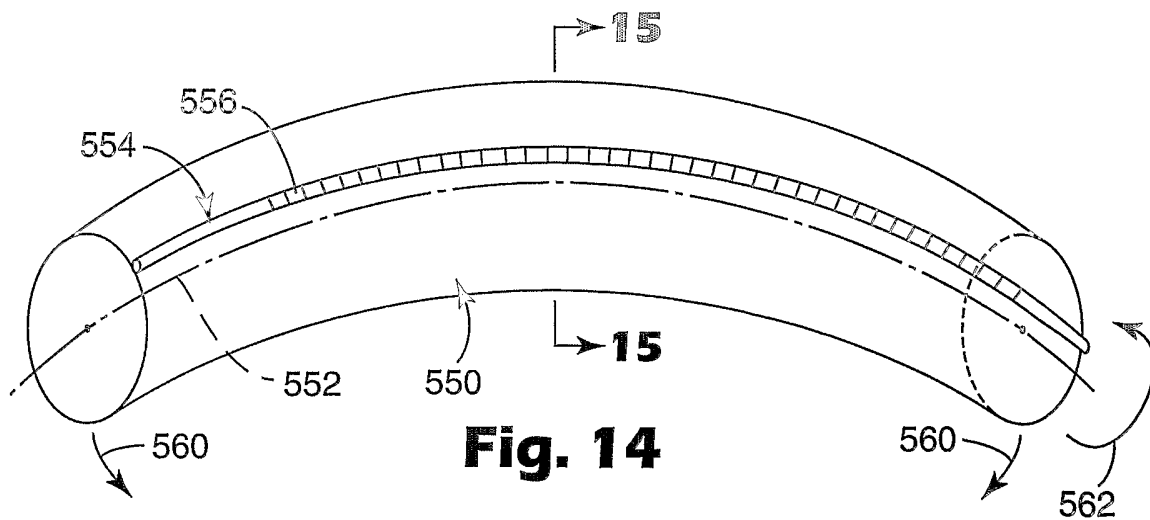

Fig. 14

9/16

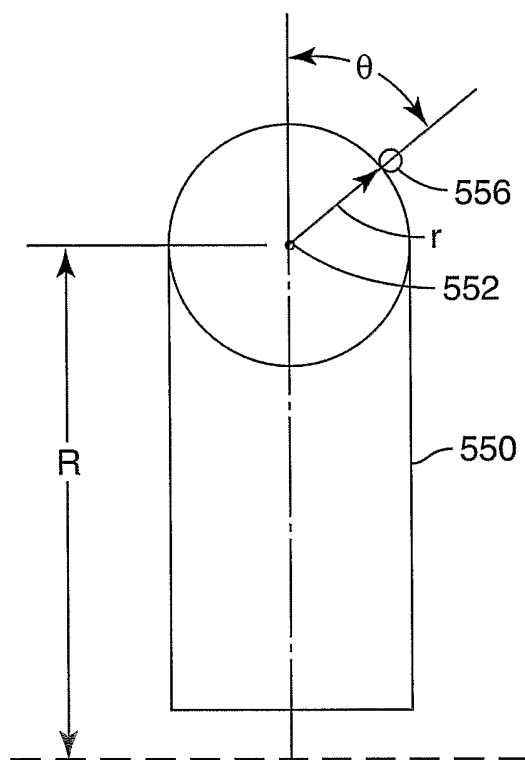

Fig. 15

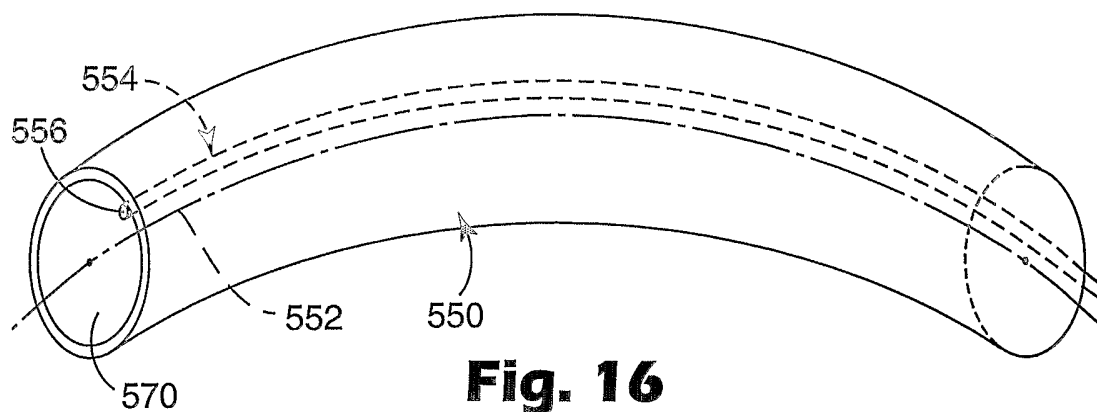

Fig. 16

1016

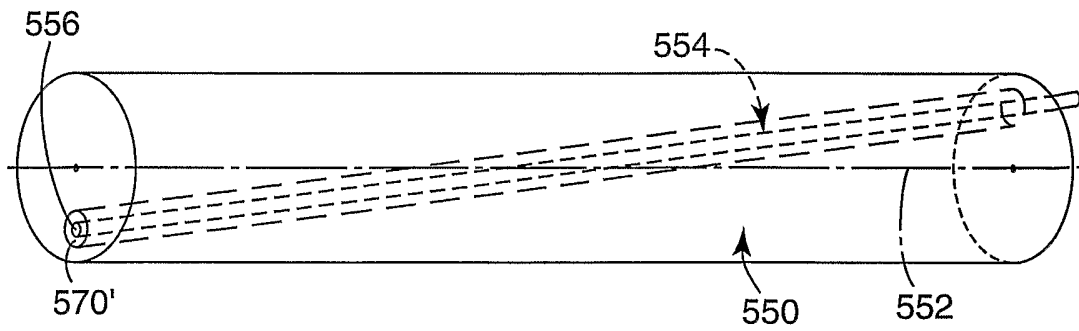

Fig. 17

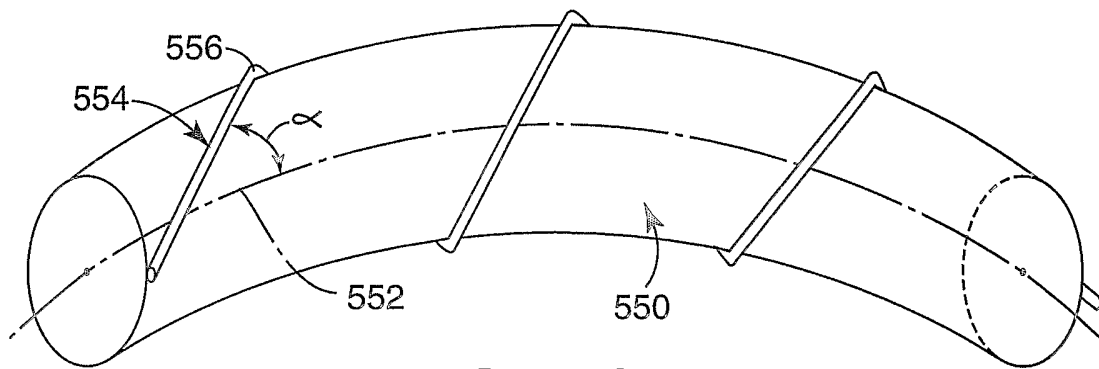

Fig. 18A

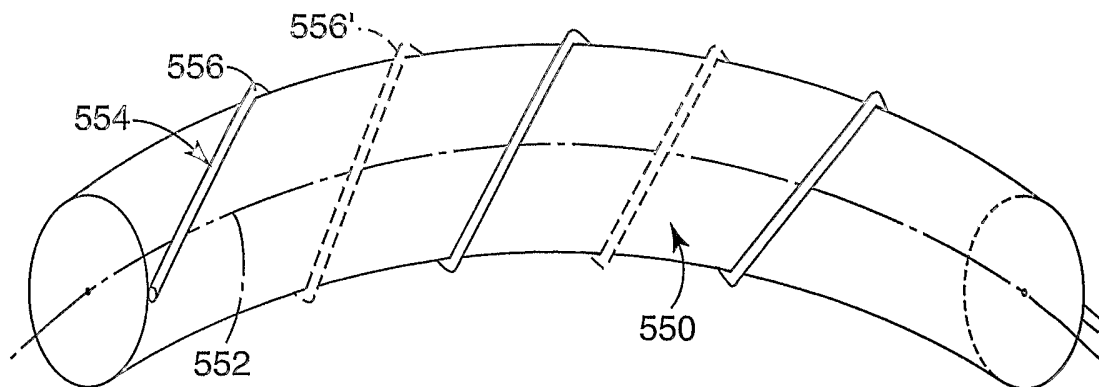

Fig. 18B

11/16

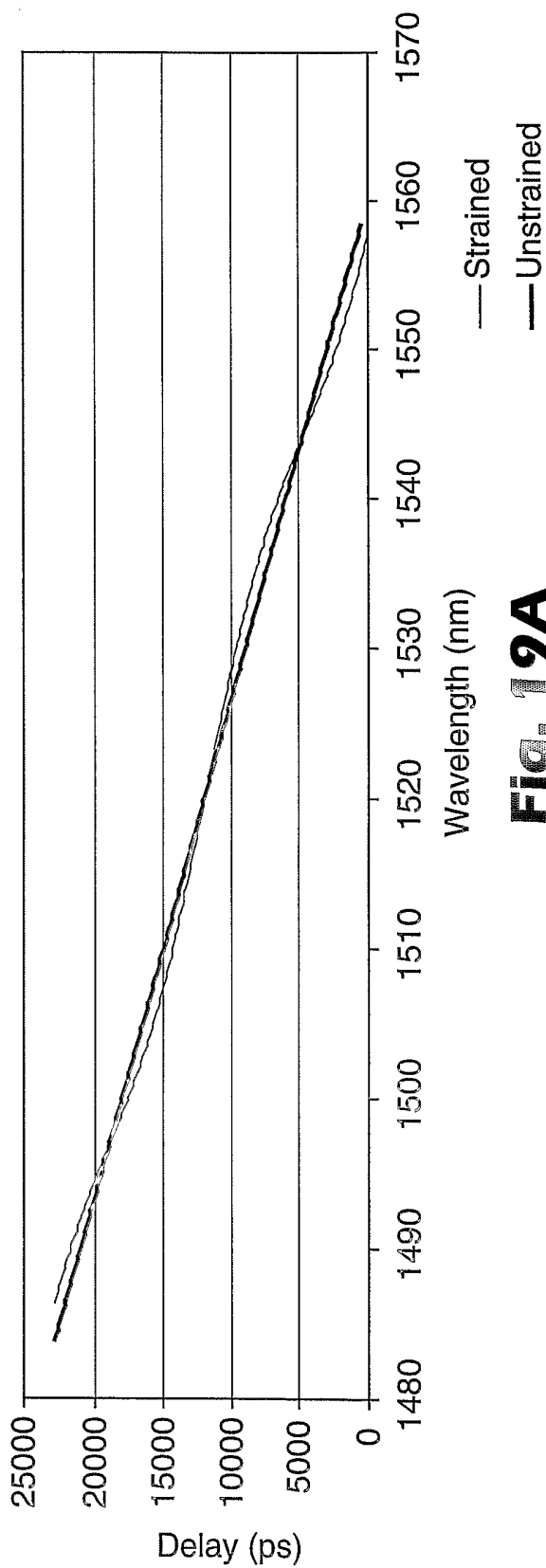

Fig. 19A

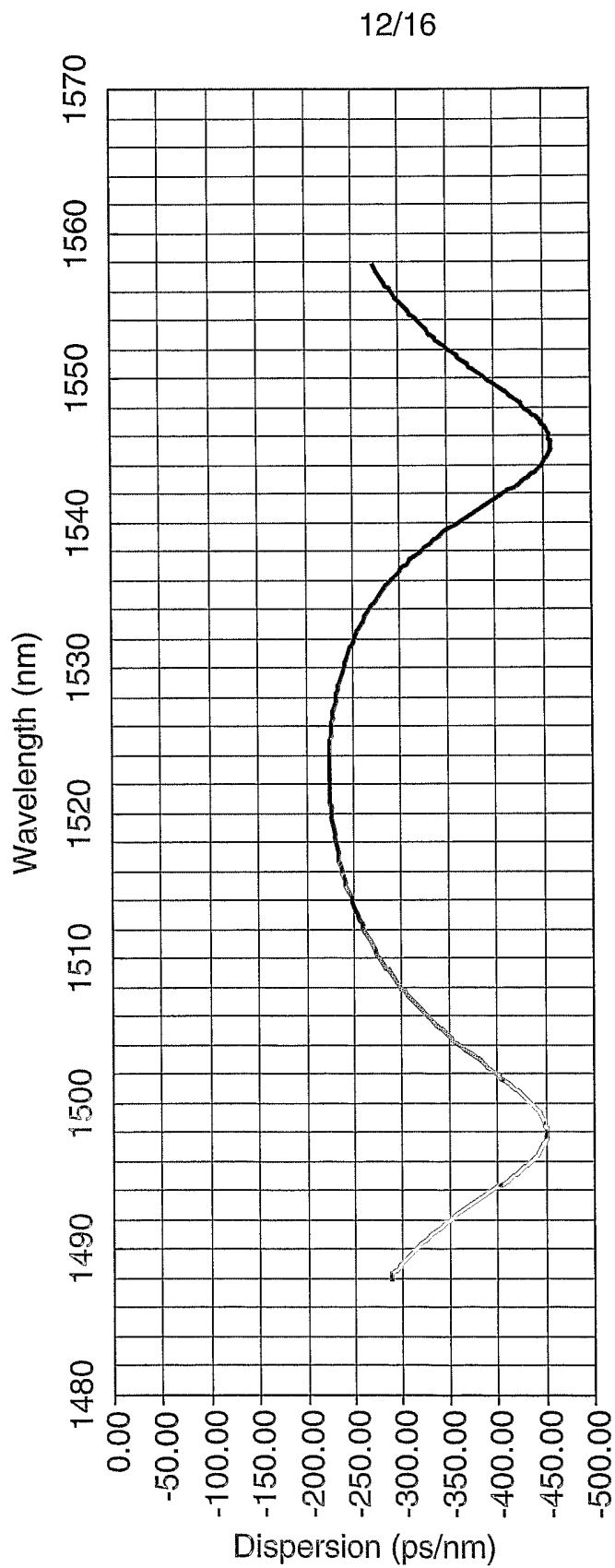

FIG. 19B

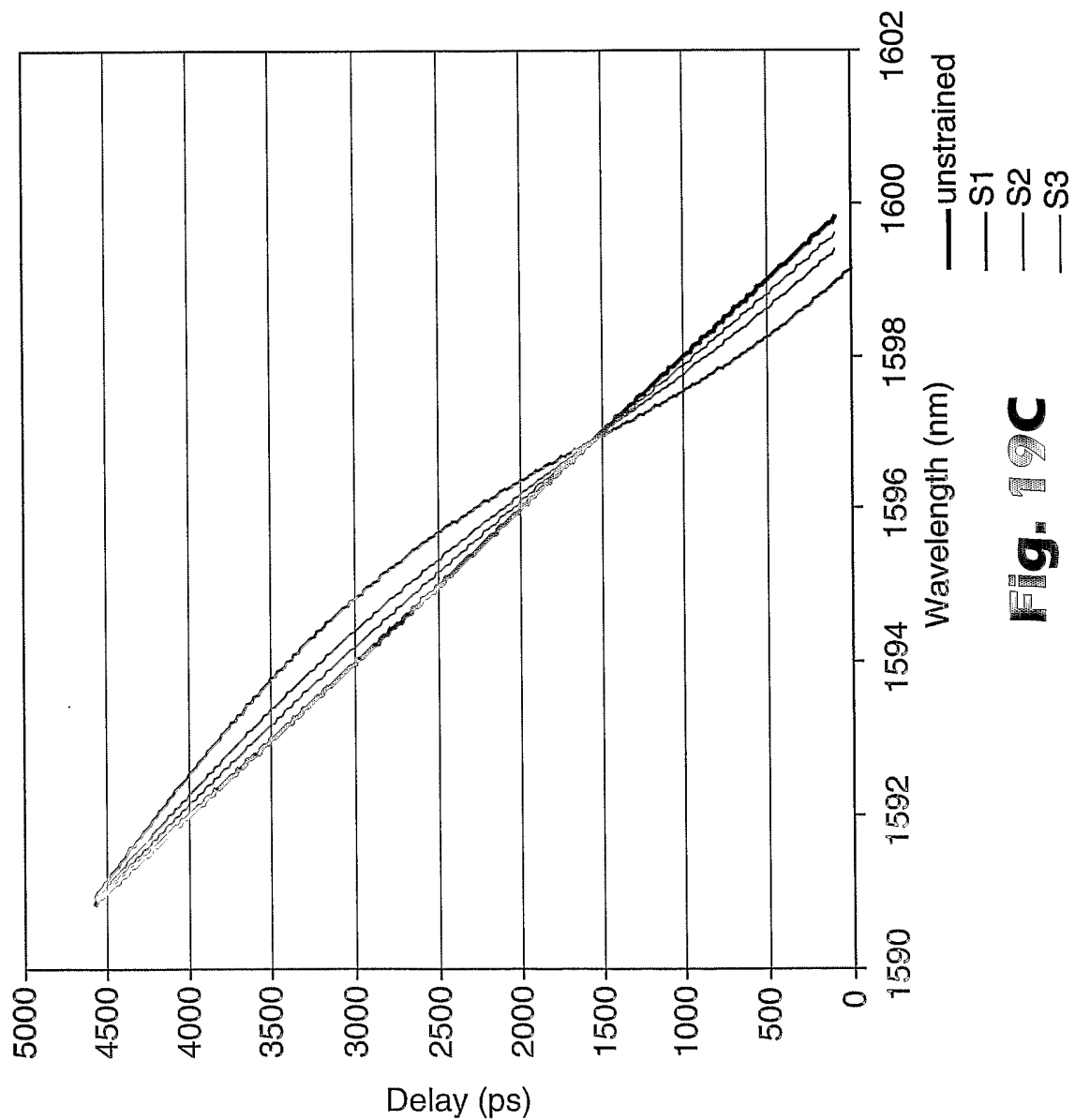

Fig. 19C

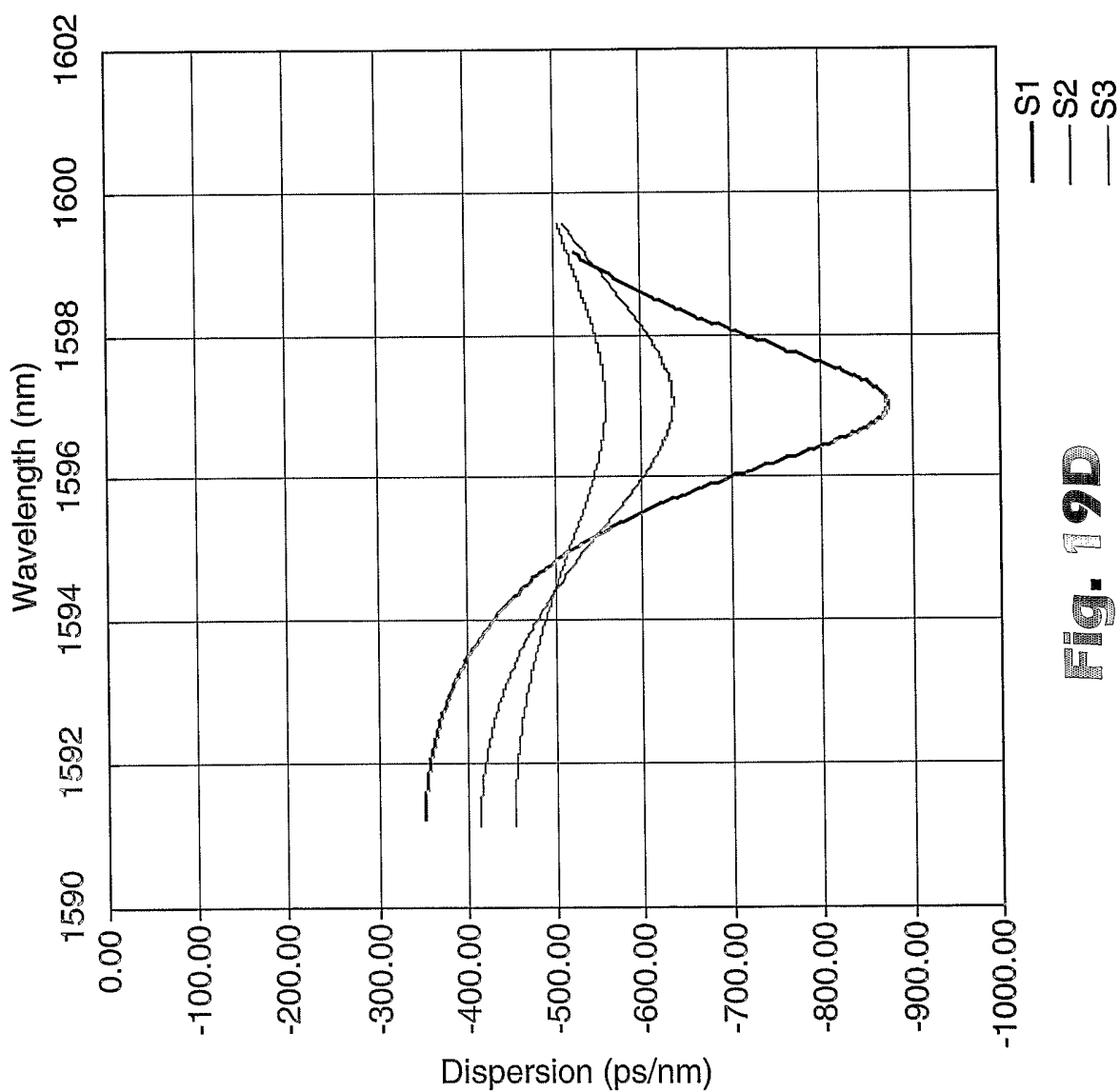
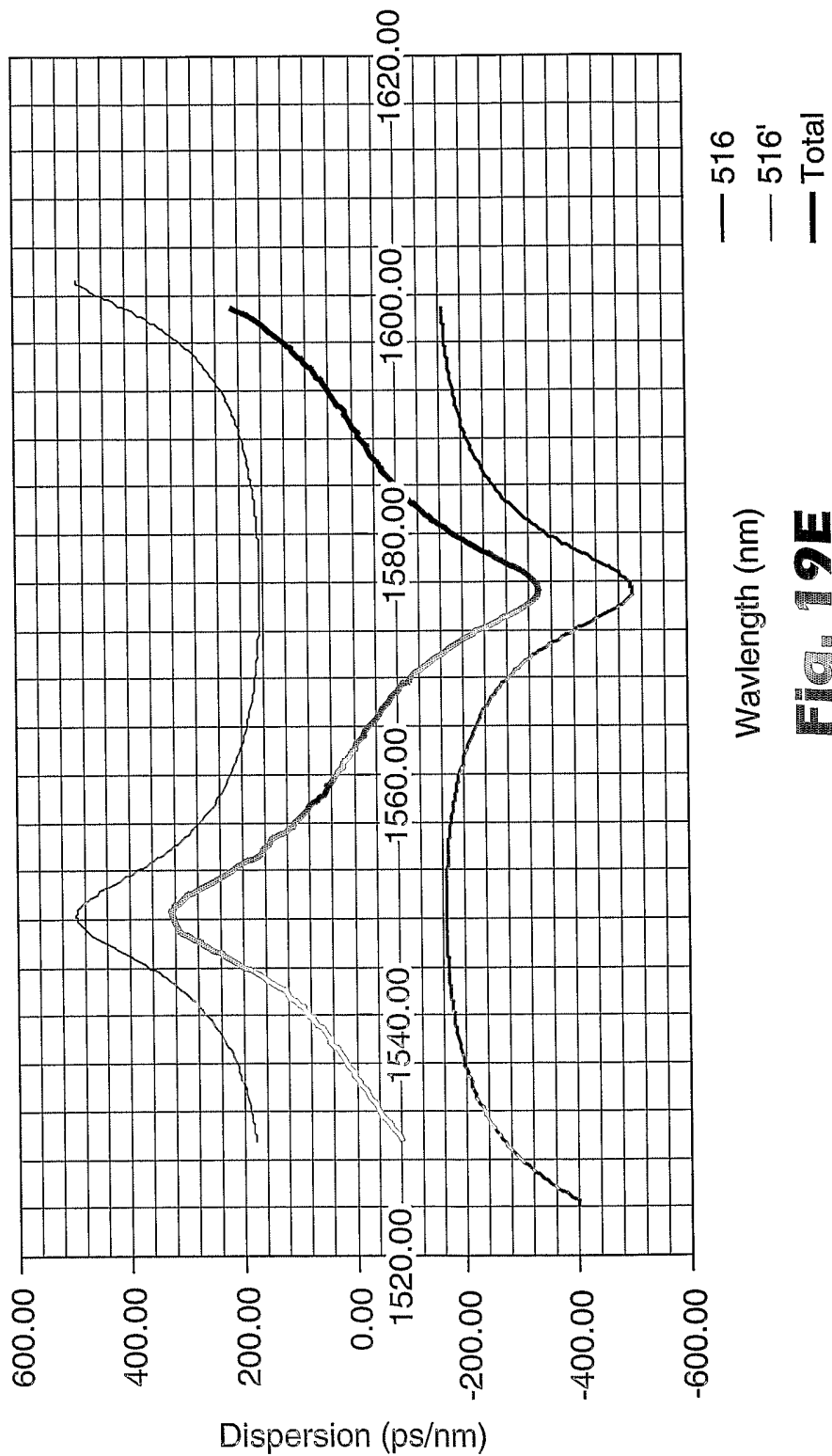

Fig. 19D



Wavelength (nm)

FIG. 19E

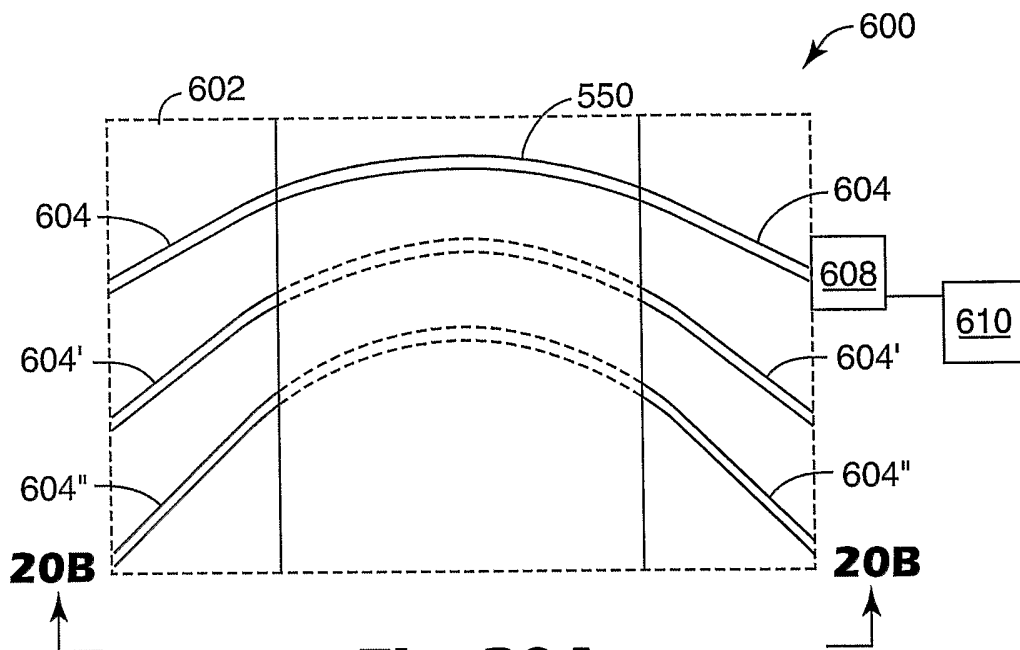

Fig. 20A

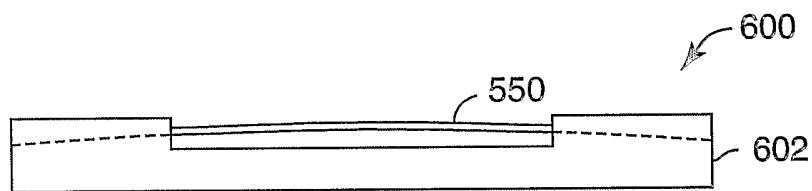

Fig. 20B

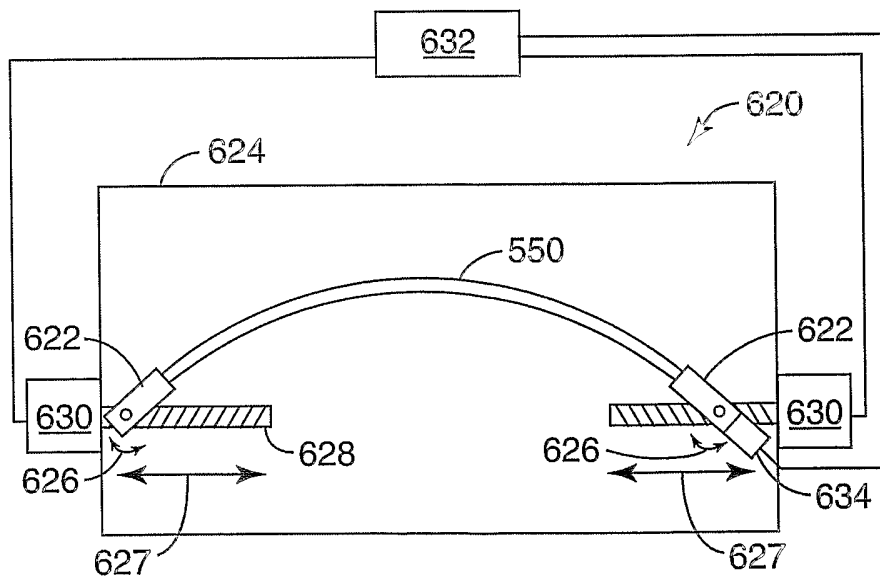

Fig. 21