



- (51) **International Patent Classification:**
A61F 2/07 (2013.01)
- (21) **International Application Number:**
PCT/IL2014/050174
- (22) **International Filing Date:**
18 February 2014 (18.02.2014)
- (25) **Filing Language:** English
- (26) **Publication Language:** English
- (30) **Priority Data:**
61/775,964 11 March 2013 (11.03.2013) US
- (71) **Applicant:** ENDOSPAN LTD. [IL/IL]; 4 Maskit Street,
P.O. Box 12058, 46733 Herzilyia Pituach (IL).
- (72) **Inventors:** SHALEV, Alon; 9 Wingate Street, 43587
Ra'anana (IL). MARMUR, Yaniv; Yeffe Nof Street,
20600 Yokneam Moshava (IL).
- (74) **Agents:** SANFORD T. COLB & CO. et al.; P.O. Box
2273, 76122 Rehovot (IL).
- (81) **Designated States** (unless otherwise indicated, for every
kind of national protection available): AE, AG, AL, AM,
AO, AT, AU, AZ, BA, BB, BG, BH, BN, BR, BW, BY,
BZ, CA, CH, CL, CN, CO, CR, CU, CZ, DE, DK, DM,

DO, DZ, EC, EE, EG, ES, FI, GB, GD, GE, GH, GM, GT,
HN, HR, HU, ID, IL, IN, IR, IS, JP, KE, KG, KN, KP, KR,
KZ, LA, LC, LK, LR, LS, LT, LU, LY, MA, MD, ME,
MG, MK, MN, MW, MX, MY, MZ, NA, NG, NI, NO, NZ,
OM, PA, PE, PG, PH, PL, PT, QA, RO, RS, RU, RW, SA,
SC, SD, SE, SG, SK, SL, SM, ST, SV, SY, TH, TJ, TM,
TN, TR, TT, TZ, UA, UG, US, UZ, VC, VN, ZA, ZM,
ZW.

- (84) **Designated States** (unless otherwise indicated, for every
kind of regional protection available): ARIPO (BW, GH,
GM, KE, LR, LS, MW, MZ, NA, RW, SD, SL, SZ, TZ,
UG, ZM, ZW), Eurasian (AM, AZ, BY, KG, KZ, RU, TJ,
TM), European (AL, AT, BE, BG, CH, CY, CZ, DE, DK,
EE, ES, FI, FR, GB, GR, HR, HU, IE, IS, IT, LT, LU, LV,
MC, MK, MT, NL, NO, PL, PT, RO, RS, SE, SI, SK, SM,
TR), OAPI (BF, BJ, CF, CG, CI, CM, GA, GN, GQ, GW,
KM, ML, MR, NE, SN, TD, TG).

Published:

- with international search report (Art. 21(3))
- before the expiration of the time limit for amending the
claims and to be republished in the event of receipt of
amendments (Rule 48.2(h))

(54) **Title:** MULTI-COMPONENT STENT-GRAFT SYSTEM FOR AORTIC DISSECTIONS

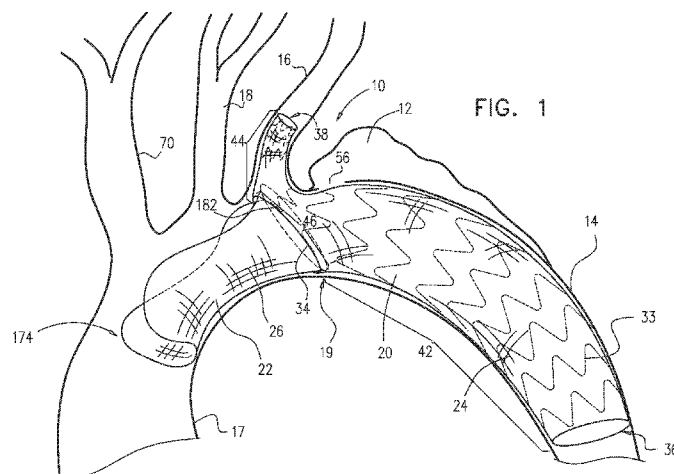

(57) **Abstract:** A generally tubular stent-graft has distal and proximal stent-graft ends and includes a generally tubular support element and a covering element. When the stent-graft is unconstrained in a radially-expanded state: the covering and support elements are shaped so as to together define a lateral fenestration having distal and proximal fenestration ends, a perimeter of the distal stent-graft end equals at least 200% of a perimeter of the proximal stent-graft end, and the stent-graft includes a dissection-reinforcement axial portion, which (a) has a proximal dissection-reinforcement end that is disposed no more than 20 mm proximal to the proximal fenestration end, extends along the stent-graft for a distance equal to between 5% and 32% of a greatest perimeter of the stent-graft distally to the distal fenestration end, and (c) has a radial strength that is at least 10% greater than an average radial strength of the entire stent-graft.

MULTI-COMPONENT STENT-GRAFT SYSTEM FOR AORTIC DISSECTIONS

CROSS-REFERENCE TO RELATED APPLICATION

The present application claims priority from US Provisional Application 61/775,964, filed March 11, 2013, which is assigned to the assignee of the present
5 application and is incorporated herein by reference.

FIELD OF THE APPLICATION

The present application relates generally to prostheses and surgical methods, and specifically to tubular prostheses, including endovascular grafts and stent-grafts, and surgical techniques for using the prostheses to maintain patency of body passages such as
10 blood vessels, and treating dissections of arterial walls and/or aneurysms.

BACKGROUND OF THE APPLICATION

Blood vessels occasionally weaken or even rupture. For example, in the aortic artery, the vascular wall can weaken or tear, resulting in dangerous conditions such as aneurysm and dissection. Treatment of such conditions can be performed by implanting a
15 prosthesis within the vascular system using minimally-invasive surgical procedures. An endoluminal prosthesis typically includes one or more stents affixed to graft material and is delivered to the treatment site by endovascular insertion. Once the endoluminal prosthesis is radially enlarged, it should remain in place indefinitely by self-attachment to the vessel wall, acting as a substitute vessel for the flow of blood or other fluids.

20 Aortic dissection is a tear or partial tear in the inner wall of the aorta, which causes blood to flow between the layers of the wall of the aorta, forcing the layers apart. Aortic dissections may be divided into two types in accordance with the Stanford classification: Type A dissections involve the ascending aorta and/or aortic arch, and possibly the descending aorta. Type B dissections involves the descending aorta or the arch (distal to
25 right brachiocephalic artery origin), without involvement of the ascending aorta.

SUMMARY OF THE APPLICATION

In some applications of the present invention, a multi-component stent-graft system is provided for treating a Type B aortic dissection. The system is configured to be deployed in the thoracic aorta and the left subclavian artery, and, optionally, the left

common carotid artery. The stent-grafts of the system are assembled in situ to accommodate the dimensions of the particular patient's anatomy, generally without requiring prior customization of the stent-grafts or in situ modifications to the stent-grafts, which might be expensive and/or complex. Typically, upon deployment, the multi-
5 component stent-graft system defines a blood-flow path from the ascending aorta, over the aortic arch, and to the descending aorta. The multi-component stent-graft system additionally provides or allows blood-flow paths to the three branches of the aortic arch.

The multi-component stent-graft system comprises a main module and, for some applications, a secondary module. The main module comprises a generally tubular main
10 stent-graft, and the secondary module comprises a non-bifurcated secondary stent-graft. The stent-grafts are configured to assume radially-compressed states for delivery, and radially-expanded states upon being deployed.

The main stent-graft typically comprises a main generally tubular support element and a main covering element that is attached to and at least partially covers the main
15 support element. The support element typically comprises a plurality of main structural stent elements. For some applications, the main structural stent elements are arranged as a plurality of circumferential stent springs.

The main covering element and the main support element are shaped so as to together define a lateral fenestration, e.g., exactly one lateral fenestration, through the
20 main stent-graft, when the main stent-graft is unconstrained in its radially-expanded state.

For some applications, when the main stent-graft is unconstrained in its radially-expanded state, i.e., no forces are applied to the stent-graft by a delivery tool, walls of a blood vessel, or otherwise, a first perimeter of a distal main-module end of the main stent-graft (and the main module) is greater than a second perimeter of a proximal main-module
25 end of the main stent-graft (and the main module). For example, the first perimeter may equal at least 150% of the second perimeter, such as at least 200%, at least 250%, at least 300%, or at least 400% of the second perimeter.

For some applications, the main stent-graft is sized and configured to positioned such that (a) a distal, radially larger, descending-aorta axial portion of the stent-graft,
30 including the distal main-module end thereof, is disposed in the aorta downstream from the bifurcation with the left subclavian artery, at least partially in the upper part of the descending aorta, (b) a proximal, radially smaller, supra-arch axial portion of the main

stent-graft, including the proximal main-module end thereof, is disposed in the left subclavian artery, and (c) an arch axial portion, axially between the descending-aorta axial portion and the supra-arch axial portion, is disposed in the aortic arch.

For some applications, when the main stent-graft is unconstrained in its radially-expanded state, the main stent-graft includes a dissection-reinforcement axial portion, which (a) includes a portion of the main structural stent elements, (b) has a proximal dissection-reinforcement end that is disposed along the stent-graft no more than 20 mm proximal to the proximal fenestration end, and/or (c) extends along the stent-graft for a distance equal to between 5% and 32% of a greatest perimeter of the stent-graft distally to the distal fenestration end.

For some applications, the dissection-reinforcement axial portion has a radial strength that is at least 10% greater than an average radial strength of the entire main stent-graft. This greater strength increases the force that the dissection-reinforcement axial portion applies to a tear of the aortic dissection, thereby sealing the tear. (It is noted that providing the entire length of the main stent-graft with a high strength has at least two drawbacks: stent-grafts with higher strengths are more difficult to deploy, and are more likely to cause damage to the vasculature.) For some applications, the dissection-reinforcement axial portion is configured to be generally straight when the main stent-graft is unconstrained in the radially-expanded state.

For some applications, the main structural stent elements of the dissection-reinforcement axial portion are arranged as a plurality of circumferential stent springs of the dissection-reinforcement axial portion. For some applications, a height, measured axially along the main stent-graft, of at least one of the stent springs of the dissection-reinforcement axial portion varies by less than 10% around a circumference of the stent spring when the main stent-graft is unconstrained in the radially-expanded state.

For some applications, the portion of structural stent elements included by the dissection-reinforcement axial portion is a first portion of the structural stent elements, and when the stent-graft is unconstrained in the radially-expanded state: (a) the main stent-graft includes a distal-end axial portion, which includes a second portion of the structural stent elements, (b) the distal-end axial portion axially extends along the stent-graft from the distal main-module end for a distance equal to between 5% and 32% of a greatest perimeter of the main stent-graft distally to a distal end of the lateral fenestration,

and (c) the distal-end axial portion has a radial strength that is at least a 10% greater than the average radial strength of the entire main stent-graft.

For some applications, the dissection-reinforcement axial portion includes a first plurality of the stent springs, and the main stent-graft includes a distal axial portion, which includes a second plurality of the stent springs. The distal axial portion is disposed along the main stent-graft distal and axially adjacent to the distal dissection-reinforcement end, and extends along the main stent-graft for a distance equal to between 5% and 32% of the greatest perimeter of the main stent-graft distally to the distal fenestration end. Typically, the distal axial portion extends to and reaches the distal main-module end. The stent springs have respective average heights, measured axially along the main stent-graft (the height of each stent spring is averaged circumferentially around the stent-graft). An average of the average heights of the first plurality of the stent springs is less than 75% of the average height of a proximal-most one of the second plurality of the stent springs. For these applications, the dissection-reinforcement axial portion is typically configured to be generally straight when the main stent-graft is unconstrained in the radially-expanded state.

The secondary stent-graft typically comprises a secondary generally tubular support element and a secondary covering element that is attached to and at least partially covers the secondary support element. The support element typically comprises a plurality of secondary structural stent elements. When the secondary module (and the secondary stent-graft) is unconstrained in the radially-expanded state thereof:

- the secondary module is shaped so as to define a proximal secondary-module end, a sealing interface distal to the proximal secondary-module end, and a central longitudinal axis therebetween. The sealing interface is sized and configured to form a blood-impervious seal with the lateral fenestration of the main module;
- the secondary module is shaped so as to define a distal secondary-module end; and
- the secondary covering element is shaped so as to define at least one lateral opening that begins at and extends from the proximal secondary-module end toward the sealing interface along the central longitudinal axis for a distance equal to at least 50% of a greatest width of the secondary module, measured

perpendicular to the central longitudinal axis.

For some applications, at least one of the secondary structural stent elements traverses the lateral opening when the secondary module is unconstrained in the radially-expanded state thereof. Such traversal may provide additional structural strength to the
5 secondary module at the lateral opening.

In some applications of the present invention, another configuration of secondary module is provided. In this configuration, when the secondary module is unconstrained in the radially-expanded state thereof:

- 10 • the at least one lateral opening includes at least first and second lateral openings;
- the secondary covering element is shaped so as to define the first and second lateral openings, each of which begins at and extends from the proximal secondary-module end toward the sealing interface along the central longitudinal axis for the distance equal to at least 50% of the greatest width of
15 the secondary module;
- the first and second lateral openings face in different first and second radial directions extending from the central longitudinal axis; and
- the first and the second lateral openings at least partially axially overlap along the central longitudinal axis.

20 For some applications, the first and the second lateral openings axially coincide along the central longitudinal axis. For some applications, the first and the second radial directions are opposite each other; in other words the first and second lateral openings face in radially-opposite directions.

In some applications of the present invention, further alternative configurations of
25 secondary module are provided. In these configurations, when the secondary module is unconstrained in the radially-expanded state thereof, (a) the secondary covering element is shaped so as to define at least one secondary-module lateral fenestration disposed distal to the proximal secondary-module end and proximal to the sealing interface, and (b) a greatest axial length of the secondary-module lateral fenestration equals at least 33% of
30 the first perimeter of the distal main-module end of the main stent-graft of the main module, when the main module is unconstrained in the radially-expanded state thereof.

For some applications, a greatest width of the secondary-module lateral fenestration, measured circumferentially around the secondary module, equals at least 16% of the first perimeter of the distal main-module end of the main stent-graft of the main module.

For some applications, the secondary module further comprises a flexible sheet,
5 which (a) is blood-sealingly joined to a portion of the secondary border, which portion extends around at least 25% of a perimeter of the secondary border and includes a distal end of the secondary border when the secondary module is unconstrained in the radially-expanded state thereof, and (b) extends radially inward from the secondary border (toward
10 or past the central longitudinal axis) when the secondary module is unconstrained in the radially-expanded state thereof. For some applications, a portion of the secondary structural stent elements are attached to the flexible sheet, which facilitates the radially-inward extension of the flexible sheet from secondary border.

There is therefore provided, in accordance with an application of the present invention, apparatus including a generally tubular stent-graft, which has distal and
15 proximal stent-graft ends and includes:

a generally tubular support element, which includes a plurality of structural stent elements; and

a covering element that is attached to and at least partially covers the support element,

20 wherein when the stent-graft is unconstrained in a radially-expanded state:

the covering element and the support element are shaped so as to together define a lateral fenestration having distal and proximal fenestration ends,

a first perimeter of the distal stent-graft end equals at least 200% of a second perimeter of the proximal stent-graft end, and

25 the stent-graft includes a dissection-reinforcement axial portion, which (a) includes a portion of the structural stent elements, (b) has (i) a distal dissection-reinforcement end and (ii) a proximal dissection-reinforcement end that is disposed along the stent-graft no more than 20 mm proximal to the proximal fenestration end, (c) extends along the stent-graft for a distance equal to between
30 5% and 32% of a greatest perimeter of the stent-graft distally to the distal fenestration end, and (d) has a radial strength that is at least 10% greater than an average radial strength of the entire stent-graft.

For some applications:

the portion of the structural stent elements included by the dissection-reinforcement axial portion is a first portion of the structural stent elements, and when the stent-graft is unconstrained in the radially-expanded state:

5 the stent-graft includes a distal-end axial portion, which includes a second portion of the structural stent elements, and

the distal-end axial portion axially extends along the stent-graft from the distal end of stent-graft for a distance equal to between 5% and 32% of a greatest perimeter of the stent-graft distally to the distal fenestration end, and

10 the distal-end axial portion has a radial strength that is at least a 10% greater than the average radial strength of the entire stent-graft.

For some applications, an axial length of the dissection-reinforcement axial portion is between 1 and 3 cm when the stent-graft is unconstrained in the radially-expanded state.

15 For some applications, the proximal dissection-reinforcement end is disposed along the stent-graft no more proximal than the distal fenestration end when the stent-graft is unconstrained in the radially-expanded state. Alternatively, for some applications, the proximal dissection-reinforcement end is disposed along the stent-graft between the distal fenestration end and the proximal fenestration end, inclusive, when the stent-graft is
20 unconstrained in the radially-expanded state.

For some applications, a distance between the distal dissection-reinforcement end and the distal stent-graft end equals between 32% and 160% of a largest perimeter of the stent-graft when the stent-graft is unconstrained in the radially-expanded state.

25 For some applications, the dissection-reinforcement axial portion extends along the stent-graft for a distance equal to between 10% and 22% of a greatest perimeter of the stent-graft distally to the distal fenestration end when the stent-graft is unconstrained in the radially-expanded state.

For some applications, the first perimeter equals at least 250% of the second perimeter.

30 For any of the applications described above, the dissection-reinforcement axial portion may be configured to be generally straight when the stent-graft is unconstrained in

the radially-expanded state.

For any of the applications described above, the structural stent elements of the dissection-reinforcement axial portion may be arranged as a plurality of circumferential stent springs, and a height, measured axially along the stent-graft, of at least one of the
5 stent springs may vary by less than 10% around a circumference of the stent spring when the stent-graft is unconstrained in the radially-expanded state.

For any of the applications described above, the structural stent elements of the dissection-reinforcement axial portion may be arranged as a plurality of circumferential stent springs, and for each one of the stent springs, a height, measured axially along the
10 stent-graft, of the stent spring may vary by less than 10% around a circumference of the stent spring when the stent-graft is unconstrained in the radially-expanded state.

For any of the applications described above, the first perimeter may be between 5 and 15 cm, and the second perimeter may be between 2.5 and 5.7 cm.

For any of the applications described above, the stent-graft may be shaped so as to
15 define exactly one lateral fenestration when the stent-graft is unconstrained in the radially-expanded state.

For any of the applications described above, the lateral fenestration may be an inferior first lateral fenestration, which faces in a first radial direction, and when the main stent-graft is unconstrained in the radially-expanded state, the main covering element and
20 the main support element may be shaped so as to together define a superior second lateral fenestration, which faces in a second radial direction generally opposite the first radial direction.

There is further provided, in accordance with an application of the present invention, apparatus including a generally tubular stent-graft, which has distal and
25 proximal stent-graft ends and includes:

a generally tubular support element, which includes a plurality of structural stent elements arranged as a plurality circumferential stent springs; and

a covering element that is attached to and at least partially cover the support element,

30 wherein when the stent-graft is unconstrained in a radially-expanded state:

the covering element and the support element are shaped so as to together

define a lateral fenestration having distal and proximal fenestration ends,

a first perimeter of the distal stent-graft end equals at least 200% of a second perimeter of the proximal stent-graft end,

the stent-graft includes a dissection-reinforcement axial portion, which (a) includes a first plurality of the stent springs, (b) has (i) a distal dissection-reinforcement end and (ii) a proximal dissection-reinforcement end that is disposed along the stent-graft no more than 20 mm proximal to the proximal fenestration end, (c) extends along the stent-graft for a distance equal to between 5% and 32% of a greatest perimeter of the stent-graft distally to the distal fenestration end, and (d) is configured to be generally straight,

the stent-graft includes a distal axial portion, which (a) includes a second plurality of the stent springs, (b) is disposed along the stent-graft distal and axially adjacent to the distal dissection-reinforcement end, (c) extends along the stent-graft for a distance equal to between 5% and 32% of the greatest perimeter of the stent-graft distally to the distal fenestration end,

the stent springs have respective average heights, measured axially along the stent-graft, and

an average of the average heights of the first plurality of the stent springs is less than 75% of the average height of a proximal-most one of the second plurality of the stent springs.

For some applications, each of the average heights of the first plurality of the stent springs is less than 75% of the average heights of the proximal-most one of the second plurality of stent springs when the stent-graft is unconstrained in the radially-expanded state.

For some applications, the average of the average heights of the first plurality of the stent springs is less than 75% of the average height of a second one of the second plurality of stent springs, other than the proximal-most one of the second plurality of stent springs when the stent-graft is unconstrained in the radially-expanded state.

For some applications, the average of the average heights of the first plurality of the stent springs is less than 75% of each of the average heights of the second plurality of stent springs when the stent-graft is unconstrained in the radially-expanded state.

For some applications, the distal axial portion is configured to be generally

straight when the stent-graft is unconstrained in the radially-expanded state.

For some applications, an axial length of the dissection-reinforcement axial portion is between 1 and 3 cm when the stent-graft is unconstrained in the radially-expanded state.

5 For some applications, the proximal dissection-reinforcement end is disposed along the stent-graft no more proximal than the distal fenestration end when the stent-graft is unconstrained in the radially-expanded state.

For some applications, the proximal dissection-reinforcement end is disposed along the stent-graft between the distal fenestration end and the proximal fenestration end,
10 inclusive, when the stent-graft is unconstrained in the radially-expanded state.

For some applications, an axial spacing between two of the first plurality of the stent springs equals less than 10% of an average of the average heights of the two stent springs.

For some applications, the first perimeter equals at least 300% of the second
15 perimeter.

For some applications, the dissection-reinforcement axial portion extends along the stent-graft for a distance equal to between 10% and 32% of the greatest perimeter of the stent-graft distally to the distal fenestration end when the stent-graft is unconstrained in the radially-expanded state.

20 For some applications, the distal axial portion extends to and reaches the distal stent-graft end.

For any of the applications described above, the average height of at least one of the first plurality of stent springs may vary by less than 10% around a circumference of the stent spring when the stent-graft is unconstrained in the radially-expanded state.

25 For any of the applications described above, for each one of the first plurality of stent springs, the average height thereof may vary by less than 10% around a circumference of the stent spring when the stent-graft is unconstrained in the radially-expanded state.

For any of the applications described above, optionally:
30 if the distal axial portion, when the stent-graft is in the radially-expanded state, is

placed and constrained in a first curved tube having a circular cross-section and an inner diameter equal to an outer diameter of the distal axial portion, the distal axial portion experiences kinking only when at least an axial portion of the first curved tube has less than a first radius of curvature, and

5 if the dissection-reinforcement axial portion, when the stent-graft is in the radially-expanded state, is placed and constrained in a second curved tube having a circular cross-section and an inner diameter equal to an outer diameter of the dissection-reinforcement axial portion, the dissection-reinforcement axial portion experiences kinking only when at least an axial portion of the second curved tube has less than a second radius of curvature,
10 which second radius of curvature is at least 30% less than the first radius of curvature.

For any of the applications described above, the lateral fenestration may be an inferior first lateral fenestration, which faces in a first radial direction, and when the main stent-graft is unconstrained in the radially-expanded state, the main covering element and the main support element may be shaped so as to together define a superior second lateral
15 fenestration, which faces in a second radial direction generally opposite the first radial direction.

There is still further provided, in accordance with an application of the present invention, apparatus including a stent-graft system, which includes:

a main module, which has distal and proximal main-module ends, and includes a
20 generally tubular main stent-graft, which includes (a) a main generally tubular support element, which includes main structural stent elements, and (b) a main covering element that is attached to and at least partially covers the support element, wherein the main covering element and the main support element are shaped so as to together define a lateral fenestration when the main module is unconstrained in a radially-expanded state
25 thereof; and

a secondary module, which includes a non-bifurcated secondary stent-graft, which includes (a) a secondary support element, which includes secondary structural stent elements, and (b) a secondary covering element that is attached to and at least partially covers the secondary support element,

30 wherein when the secondary module is unconstrained in a radially-expanded state thereof:

the secondary module is shaped so as to define (a) a proximal secondary-

module end, (b) a sealing interface distal to the proximal secondary-module end, and (c) a central longitudinal axis therebetween, wherein the sealing interface is sized and configured to form a blood-impervious seal with the lateral fenestration of the main module, and

5 the secondary covering element is shaped so as to define at least one lateral opening that begins at and extends from the proximal secondary-module end toward the sealing interface along the central longitudinal axis for a distance equal to at least 50% of a greatest width of the secondary module, measured perpendicular to the central longitudinal axis.

10 For some applications, a greatest width of the at least one lateral opening, measured circumferentially around the secondary module, equals at least 90 degrees circumferentially around the proximal secondary-module end, the 90 degrees being measured at the sealing interface.

15 For some applications, at least one of the secondary structural stent elements traverses the at least one lateral opening when the secondary module is unconstrained in the radially-expanded state thereof.

20 For some applications, the at least one lateral opening extends from the proximal secondary-module end toward the sealing interface along at least 70% of a greatest width of the secondary module, measured perpendicular to the central longitudinal axis when the secondary module is unconstrained in the radially-expanded state thereof.

 For some applications, the cross-sectional area of the secondary module, measured perpendicular to the central longitudinal axis, gradually tapers from the proximal secondary-module end to the sealing interface when the secondary module is unconstrained in the radially-expanded state thereof.

25 For any of the applications described above, when the secondary module is unconstrained in the radially-expanded state thereof:

 the at least one lateral opening may include at least first and second lateral openings,

30 the secondary covering element may be shaped so as to define the first and the second lateral openings, each of extends from the proximal secondary-module end toward the sealing interface along the central longitudinal axis for the distance equal to at least 50% of the greatest width of the secondary module,

the first and the second lateral openings may face in different first and second radial directions extending from the central longitudinal axis, and

the first and the second lateral openings may at least partially axially overlap along the central longitudinal axis.

5 For some applications, the first and the second lateral openings axially coincide along the central longitudinal axis. For some applications, the first and the second radial directions are opposite each other. For some applications, the secondary covering element is shaped so as to define two portions, which (a) extend to and reach the proximal secondary-module end, and (b) are shaped so as to define respective concave inner
10 surfaces that face each other and the central longitudinal axis, and (c) are not joined to each other at the proximal secondary-module end.

For any of the applications described above, the at least one lateral opening may include exactly one lateral opening. For some applications, when the secondary module is unconstrained in the radially-expanded state thereof, the lateral opening faces in a first
15 radial direction extending from the central longitudinal axis, and a portion of the secondary covering element that faces in a second radial direction opposite the first radial direction extends to and reaches the proximal secondary-module end.

For any of the applications described above, a first perimeter of the distal main-module end may equal at least 200%, e.g., at least 300%, of a second perimeter of the
20 proximal main-module end when the main module is unconstrained in the radially-expanded state thereof.

For any of the applications described above:

the lateral fenestration may be an inferior first lateral fenestration, which faces in a first radial direction,

25 when the main stent-graft is unconstrained in the radially-expanded state, the main covering element and the main support element may be shaped so as to together define a superior second lateral fenestration, which faces in a second radial direction generally opposite the first radial direction,

the stent-graft system may further include a generally tubular tertiary stent-graft,
30 and

the main and the tertiary stent-grafts may be configured such that the tertiary stent-graft forms a blood-impervious seal with the main stent-graft around the superior second

lateral fenestration when the tertiary stent-graft is disposed therethrough, and the main stent-graft is in the radially-expanded state thereof and the tertiary stent-graft is in a radially-expanded state thereof.

There is additionally provided, in accordance with an application of the present invention, apparatus including a stent-graft system, which includes:

a main module, which has distal and proximal main-module ends, and includes a generally tubular main stent-graft, which includes (a) a main generally tubular support element, which includes main structural stent elements, and (b) a main covering element that is attached to and at least partially covers the support element, wherein the main covering element and the main support element are shaped so as to together define a main-module lateral fenestration when the main module is unconstrained in a radially-expanded state thereof; and

a secondary module, which includes a non-bifurcated secondary stent-graft, which includes (a) a secondary support element, which includes secondary structural stent elements, and (b) a secondary covering element that is attached to and at least partially covers the secondary support element,

wherein when the secondary module is unconstrained in a radially-expanded state thereof:

the secondary module is shaped so as to define (a) a proximal secondary-module end, (b) a sealing interface distal to the proximal secondary-module end, and (c) a central longitudinal axis therebetween, wherein the sealing interface is sized and configured to form a blood-impervious seal with the main-module lateral fenestration of the main module,

the secondary covering element is shaped so as to define at least one secondary-module lateral fenestration disposed distal to the proximal secondary-module end and proximal to the sealing interface, and

a greatest axial length of the secondary-module lateral fenestration, measured parallel to the central longitudinal axis, equals at least 33% of a first perimeter of the distal main-module end when the main module is unconstrained in the radially-expanded state thereof.

For some applications, at least one of the secondary structural stent elements traverses the secondary-module lateral fenestration.

For some applications, the greatest axial length of the secondary-module lateral fenestration equals at least 50% of the first perimeter of the distal main-module end when the secondary module is unconstrained in the radially-expanded state thereof.

5 For some applications, the cross-sectional area of the secondary module gradually tapers from the proximal secondary-module end to the sealing interface when the secondary module is unconstrained in the radially-expanded state thereof.

10 For any of the applications described above, the at least one secondary-module lateral fenestration may include exactly one secondary-module lateral fenestration. For some applications, when the secondary module is unconstrained in the radially-expanded state thereof, the secondary-module lateral fenestration faces in a first radial direction extending from the central longitudinal axis, and a portion of the secondary covering element that faces in a second radial direction opposite the first radial direction extends to and reaches the proximal secondary-module end.

15 For any of the applications described above, the first perimeter of the distal main-module end may equal at least 200%, e.g., at least 300%, of a second perimeter of the proximal main-module end when the main module is unconstrained in the radially-expanded state thereof.

20 For any of the applications described above, the secondary module may further include a flexible sheet, which (a) is blood-sealingly joined to a portion of the secondary border, which portion extends around at least 25% of a perimeter of the secondary border and includes a distal end of the secondary border when the secondary module is unconstrained in the radially-expanded state thereof, and (b) extends radially inward from the secondary border when the secondary module is unconstrained in the radially-expanded state thereof. For some applications, a portion of the secondary structural stent elements are attached to the flexible sheet.

For any of the applications described above:

the main-module lateral fenestration may be an inferior first lateral fenestration, which faces in a first radial direction,

30 when the main stent-graft is unconstrained in the radially-expanded state, the main covering element and the main support element may be shaped so as to together define a superior second lateral fenestration, which faces in a second radial direction generally opposite the first radial direction,

the stent-graft system may further include a generally tubular tertiary stent-graft,
and

the main and the tertiary stent-grafts may be configured such that the tertiary stent-graft forms a blood-impervious seal with the main stent-graft around the superior second lateral fenestration when the tertiary stent-graft is disposed therethrough, and the main stent-graft is in the radially-expanded state thereof and the tertiary stent-graft is in a radially-expanded state thereof.

There is yet additionally provided, in accordance with an application of the present invention; apparatus including a stent-graft system, which includes:

10 a main module, which has distal and proximal main-module ends, and includes a generally tubular main stent-graft, which includes (a) a main generally tubular support element, which includes main structural stent elements, and (b) a main covering element that is attached to and at least partially covers the support element, wherein the main covering element and the main support element are shaped so as to together define a main-module lateral fenestration when the main module is unconstrained in a radially-expanded state thereof; and

a secondary module, which includes a non-bifurcated secondary stent-graft, which includes (a) a secondary support element, which includes secondary structural stent elements, (b) a secondary covering element that is attached to and at least partially covers the secondary support element, and (c) a flexible sheet,

20 wherein when the secondary module is unconstrained in a radially-expanded state thereof:

the secondary module is shaped so as to define (a) a proximal secondary-module end, (b) a sealing interface distal to the proximal secondary-module end, and (c) a central longitudinal axis therebetween, wherein the sealing interface is sized and configured to form a blood-impervious seal with the main-module lateral fenestration of the main module,

the secondary covering element is shaped so as to define at least one secondary-module lateral fenestration disposed distal to the proximal secondary-module end and proximal to the sealing interface, and

30 the flexible sheet (a) is blood-sealingly joined to a portion of a secondary border of the secondary-module lateral fenestration, which portion extends around at least 25% of a perimeter of the secondary border and includes a distal end of the

secondary border when the secondary module is unconstrained in the radially-expanded state thereof, and (b) extends radially inward from the secondary border when the secondary module is unconstrained in the radially-expanded state thereof.

5 For some applications, a portion of the secondary structural stent elements are attached to the flexible sheet.

For some applications:

the main-module lateral fenestration is an inferior first lateral fenestration, which faces in a first radial direction,

10 when the main stent-graft is unconstrained in the radially-expanded state, the main covering element and the main support element are shaped so as to together define a superior second lateral fenestration, which faces in a second radial direction generally opposite the first radial direction,

the stent-graft system further includes a generally tubular tertiary stent-graft, and

15 the main and the tertiary stent-grafts are configured such that the tertiary stent-graft forms a blood-impervious seal with the main stent-graft around the superior second lateral fenestration when the tertiary stent-graft is disposed therethrough, and the main stent-graft is in the radially-expanded state thereof and the tertiary stent-graft is in a radially-expanded state thereof.

20 There is also provided, in accordance with an application of the present invention, apparatus including a stent-graft system, which includes:

a main module, which has distal and proximal main-module ends, and includes a generally tubular main stent-graft, which includes (a) a main generally tubular support element, which includes main structural stent elements, and (b) a main covering element
25 that is attached to and at least partially covers the support element, wherein the main covering element and the main support element are shaped so as to together define a lateral fenestration when the main module is unconstrained in a radially-expanded state thereof; and

a secondary module, which includes a non-bifurcated secondary stent-graft, which
30 includes (a) a secondary support element, which includes secondary structural stent elements, and (b) a secondary covering element that is attached to and partially covers the secondary support element,

wherein when the secondary module is unconstrained in a radially-expanded state thereof:

the secondary module is shaped so as to define (a) a proximal secondary-module end, (b) a sealing interface distal to the proximal secondary-module end, and (c) an anchoring axial portion therebetween having a central longitudinal axis and an anchoring-portion length, measured along the central longitudinal axis from the distal sealing interface to the proximal secondary-module end,

the sealing interface is sized and configured to form a blood-impervious seal with the lateral fenestration of the main module,

the secondary covering element at least covers the secondary support element along a covered axial portion of the anchoring axial portion, which covered axial portion extends proximally from the distal sealing interface for an axial covering distance equal to between 10% and 50% of the anchoring-portion length, the axial covering distance measured along the central longitudinal axis, wherein the secondary support element is uncovered proximally to the secondary covering element, and

the anchoring axial portion has a greatest anchoring-portion width that is (a) greater than a greatest proximal-end width at the proximal secondary-module end and (b) at least 20% greater than a greatest sealing-interface width at a narrowest portion of the distal sealing interface, the greatest anchoring-portion, sealing-interface, and proximal-end widths measured perpendicular to the central longitudinal axis.

For some applications, the anchoring axial portion has the greatest anchoring-portion width at an axial location at an axial distance from the proximal secondary-module end equal to between 33% and 60% of the anchoring-portion length, the axial distance measured along the central longitudinal axis, when the secondary module is unconstrained in the radially-expanded state thereof.

For some applications, the greatest anchoring-portion width is at least 50% greater than the greatest sealing-interface width at the narrowest portion of the distal sealing interface, when the secondary module is unconstrained in the radially-expanded state thereof.

For some applications, the axial covering distance from the distal sealing interface

is equal to between 20% and 100% of an axial distance between the distal sealing interface and an axial location of the greatest anchoring-portion width, the axial distance measured along the central longitudinal axis, when the secondary module is unconstrained in the radially-expanded state thereof. For some applications, the axial covering distance
5 from the distal sealing interface is equal to between 30% and 60% of the axial distance between the distal sealing interface and the axial location of the greatest anchoring-portion width, when the secondary module is unconstrained in the radially-expanded state thereof.

For some applications, the axial covering distance equals between 10% and 35%
10 of the anchoring-portion length, when the secondary module is unconstrained in the radially-expanded state thereof.

For some applications, the axial covering distance is at least 15% of the anchoring-portion length, when the secondary module is unconstrained in the radially-expanded state thereof.

15 For any of the applications described above, the anchoring axial portion may include a plurality of the secondary structural stent elements, each of which has two longitudinal portions that extend toward the distal sealing interface, and an intermediary longitudinal portion that curves around the proximal secondary-module end, when the secondary module is unconstrained in the radially-expanded state thereof.

20 For any of the applications described above, the anchoring axial portion may include a plurality of the secondary structural stent elements, some of which touch one another, and none of which are fixed to one another, when the secondary module is unconstrained in the radially-expanded state thereof.

For any of the applications described above, an uncovered axial portion of the
25 anchoring portion may extend from the proximal secondary-module end to a proximal end of the covered axial portion, for an axial uncovered distance equal to between 30 and 120 mm, when the secondary module is unconstrained in the radially-expanded state thereof.

For any of the applications described above, the greatest proximal-end width may equal zero.

30 There is further provided, in accordance with an application of the present invention, a method for treating a patient including:

endovascularly introducing a generally tubular stent-graft, while in a radially-compressed state, and positioning the stent-graft such that (a) a proximal stent-graft end of the stent-graft is positioned in a branch of an aortic arch selected from the group consisting of: a left subclavian artery left subclavian artery, and a left common carotid artery, and (b) a distal stent-graft end of the stent-graft is positioned in a descending aorta, wherein the stent-graft includes (a) a generally tubular support element, which includes a plurality of structural stent elements, and (b) a covering element that is attached to and at least partially covers the support element; and

thereafter, transitioning the stent-graft to a radially-expanded state, in which (a) the covering element and the support element are shaped so as to together define a lateral fenestration that is disposed in the aortic arch, with the lateral fenestration facing upstream generally toward an ascending aorta, the lateral fenestration having distal and proximal fenestration ends, (b) a first perimeter of a distal stent-graft end of the stent-graft equals at least 200% of a second perimeter of the proximal stent-graft end, and (c) the stent-graft includes a dissection-reinforcement axial portion, which (i) includes a portion of the structural stent elements, (ii) has (x) a distal dissection-reinforcement end and (y) a proximal dissection-reinforcement end that is disposed along the stent-graft no more than 20 mm proximal to the proximal fenestration end, (iii) extends along the stent-graft for an axial distance equal to between 5% and 32% of a greatest perimeter of the stent-graft distally to the distal fenestration end, and (iv) has a radial strength that is at least 10% greater than an average radial strength of the entire stent-graft.

For some applications:

the lateral fenestration is an inferior first lateral fenestration, which faces in a first radial direction,

when the main stent-graft is in the radially-expanded state, the main covering element and the main support element are shaped so as to together define a superior second lateral fenestration, which faces in a second radial direction generally opposite the first radial direction, and

positioning the stent-graft includes positioning the stent-graft such that (a) the proximal stent-graft end is positioned in the left common carotid artery, (b) the inferior first lateral fenestration is disposed in the aortic arch, with the inferior first lateral fenestration facing upstream generally toward the ascending aorta, and (c) the superior second lateral fenestration is axially aligned with and faces the left subclavian artery.

There is still further provided, in accordance with an application of the present invention, a method for treating a patient including:

5 endovascularly introducing a generally tubular stent-graft, while in a radially-compressed state, and positioning the stent-graft such that (a) a proximal stent-graft end of the stent-graft is positioned in a branch of an aortic arch selected from the group consisting of: a left subclavian artery left subclavian artery, and a left common carotid artery, and (b) a distal stent-graft end of the stent-graft is positioned in a descending aorta, wherein the stent-graft includes (a) a generally tubular support element, which includes a plurality of structural stent elements arranged as a plurality circumferential stent springs, and (b) a covering element that is attached to and at least partially covers the support element; and

10 thereafter, transitioning the stent-graft to a radially-expanded state, in which (a) the covering element and the support element are shaped so as to together define a lateral fenestration that is disposed in the aortic arch, with the lateral fenestration facing upstream generally toward an ascending aorta, the lateral fenestration having distal and proximal fenestration ends, (b) a first perimeter of a distal stent-graft end of the stent-graft equals at least 200% of a second perimeter of the proximal stent-graft end, (c) the stent-graft includes a dissection-reinforcement axial portion, which (i) includes a first plurality of the stent springs, (ii) has (x) a distal dissection-reinforcement end and (y) a proximal dissection-reinforcement end that is disposed along the stent-graft no more than 20 mm proximal to the proximal fenestration end, (iii) extends along the stent-graft for a distance equal to between 5% and 32% of a greatest perimeter of the stent-graft distally to the distal fenestration end, and (iv) is configured to be generally straight when the stent-graft is unconstrained in the radially-constrained state, (d) the stent-graft includes a distal axial portion, which (i) includes a second plurality of the stent springs, (ii) is disposed along the stent-graft distal and axially adjacent to the distal dissection-reinforcement end, (iii) extends along the stent-graft for a distance equal to between 5% and 32% of the greatest perimeter of the stent-graft distally to the distal fenestration end, (e) the stent springs have respective average heights, measured axially along the stent-graft, and (f) an average of the average heights of the first plurality of the stent springs is less than 75% of the average height of a proximal-most one of the second plurality of the stent springs.

For some applications:

the lateral fenestration is an inferior first lateral fenestration, which faces in a first

radial direction,

when the main stent-graft is in the radially-expanded state, the main covering element and the main support element are shaped so as to together define a superior second lateral fenestration, which faces in a second radial direction generally opposite the first radial direction, and

5 positioning the stent-graft includes positioning the stent-graft such that (a) the proximal stent-graft end is positioned in the left common carotid artery, (b) the inferior first lateral fenestration is disposed in the aortic arch, with the inferior first lateral fenestration facing upstream generally toward the ascending aorta, and (c) the superior
10 second lateral fenestration is axially aligned with and faces the left subclavian artery.

There is additionally provided, in accordance with an application of the present invention, a method for treating a patient including:

endovascularly introducing a main module, while in a radially-compressed state thereof, and positioning the main module such that (a) a proximal main-module end of the
15 main module is positioned in a branch of an aortic arch selected from the group consisting of: a left subclavian artery left subclavian artery, and a left common carotid artery, and (b) a distal main-module end of the main module is positioned in a descending aorta, wherein the main module includes a generally tubular main stent-graft, which includes (a) a main generally tubular support element, which includes main structural stent elements, and (b)
20 a main covering element that is attached to and at least partially covers the support element;

thereafter, transitioning the main stent-graft to a radially-expanded state thereof, in which the main covering element and the main support element are shaped so as to together define a lateral fenestration that is disposed in the aortic arch, with the lateral
25 fenestration facing upstream generally toward an ascending aorta;

endovascularly introducing and passing a secondary module, while in a radially-compressed state thereof, through a distal portion of the main stent-graft such that the secondary module is disposed through the lateral fenestration and is disposed partially in the aortic arch, wherein the secondary module includes a non-bifurcated secondary stent-graft, which includes (a) a secondary support element, which includes secondary
30 structural stent elements, and (b) a secondary covering element that is attached to and at least partially covers the secondary support element; and

thereafter, transitioning the secondary module to a radially-expanded state thereof,

in which the secondary module is shaped so as to define (a) a proximal secondary-module end, (b) a sealing interface distal to the proximal secondary-module end, and (c) a central longitudinal axis therebetween, such that the sealing interface forms a blood-impervious seal with the lateral fenestration of the main module, and the secondary covering element is shaped so as to define at least one lateral opening that begins at and extends from the proximal secondary-module end toward the sealing interface along the central longitudinal axis for a distance equal to at least 50% of a greatest width of the secondary module, measured perpendicular to the central longitudinal axis.

For some applications:

the lateral fenestration is an inferior first lateral fenestration, which faces in a first radial direction,

when the main stent-graft is in the radially-expanded state, the main covering element and the main support element are shaped so as to together define a superior second lateral fenestration, which faces in a second radial direction generally opposite the first radial direction, and

positioning the stent-graft includes positioning the stent-graft such that (a) the proximal stent-graft end is positioned in the left common carotid artery, (b) the inferior first lateral fenestration is disposed in the aortic arch, with the inferior first lateral fenestration facing upstream generally toward the ascending aorta, and (c) the superior second lateral fenestration is axially aligned with and faces the left subclavian artery.

There is yet additionally provided, in accordance with an application of the present invention, a method for treating a patient including:

endovascularly introducing a main module, while in a radially-compressed state thereof, and positioning the main module such that (a) a proximal main-module end of the main module is positioned in a branch of an aortic arch selected from the group consisting of: a left subclavian artery left subclavian artery, and a left common carotid artery, and (b) a distal main-module end of the main module is positioned in a descending aorta, wherein the main module includes a generally tubular main stent-graft, which includes (a) a main generally tubular support element, which includes main structural stent elements, and (b) a main covering element that is attached to and at least partially covers the support element;

thereafter, transitioning the main stent-graft to a radially-expanded state thereof, in

which the main covering element and the main support element are shaped so as to together define a main-module lateral fenestration that is disposed in the aortic arch, with the main-module lateral fenestration facing upstream generally toward an ascending aorta;

5 endovascularly introducing and passing a secondary module, while in a radially-compressed state thereof, through a distal portion of the main stent-graft such that the secondary module is disposed through the main-module lateral fenestration and is disposed partially in the aortic arch, wherein the secondary module includes a non-bifurcated secondary stent-graft, which includes (a) a secondary support element, which includes secondary structural stent elements, and (b) a secondary covering element that is
10 attached to and at least partially covers the secondary support element; and

thereafter, transitioning the secondary module to a radially-expanded state thereof, in which the secondary module is shaped so as to define (a) a proximal secondary-module end, (b) a sealing interface distal to the proximal secondary-module end, and (c) a central longitudinal axis therebetween, such that the sealing interface forms a blood-impervious
15 seal with the main-module lateral fenestration of the main module, and the secondary covering element is shaped so as to define at least one secondary-module lateral fenestration disposed distal to the proximal secondary-module end and proximal to the sealing interface, wherein a greatest axial length of the secondary-module lateral fenestration, measured parallel to the central longitudinal axis, equals at least 33% of a
20 first perimeter of the distal main-module end.

There is also provided, in accordance with an application of the present invention, a method for treating a patient including:

25 endovascularly introducing a main module, while in a radially-compressed state thereof, and positioning the main module such that (a) a proximal main-module end of the main module is positioned in a branch of an aortic arch selected from the group consisting of: a left subclavian artery left subclavian artery, and a left common carotid artery, and (b) a distal main-module end of the main module is positioned in a descending aorta, wherein the main module includes a generally tubular main stent-graft, which includes (a) a main generally tubular support element, which includes main structural stent elements, and (b)
30 a main covering element that is attached to and at least partially covers the support element;

thereafter, transitioning the main stent-graft to a radially-expanded state thereof, in which the main covering element and the main support element are shaped so as to

together define a main-module lateral fenestration that is disposed in the aortic arch, with the main-module lateral fenestration facing upstream generally toward an ascending aorta;

endovascularly introducing and passing a secondary module, while in a radially-compressed state thereof, through a distal portion of the main stent-graft such that the secondary module is disposed through the main-module lateral fenestration and is disposed partially in the aortic arch, wherein the secondary module includes a non-bifurcated secondary stent-graft, which includes (a) a secondary support element, which includes secondary structural stent elements, (b) a secondary covering element that is attached to and at least partially covers the secondary support element, and (c) a flexible sheet; and

thereafter, transitioning the secondary module to a radially-expanded state thereof, in which (a) the secondary module is shaped so as to define (a) a proximal secondary-module end, (b) a sealing interface distal to the proximal secondary-module end, and (c) a central longitudinal axis therebetween, such that the sealing interface forms a blood-impervious seal with the main-module lateral fenestration of the main module, (b) the secondary covering element is shaped so as to define at least one secondary-module lateral fenestration disposed distal to the proximal secondary-module end and proximal to the sealing interface, and (c) the flexible sheet (i) is blood-sealingly joined to a portion of a secondary border of the secondary-module lateral fenestration, which portion extends around at least 25% of a perimeter of the secondary border and includes a distal end of the secondary border, and (ii) extends radially inward from the secondary border when the secondary module is unconstrained in the radially-expanded state thereof.

There is further provided, in accordance with an application of the present invention, a method for treating a patient including:

endovascularly introducing a main module, while in a radially-compressed state thereof, and positioning the main module such that (a) a proximal main-module end of the main module is positioned in a branch of an aortic arch selected from the group consisting of: a left subclavian artery left subclavian artery, and a left common carotid artery, and (b) a distal main-module end of the main module is positioned in a descending aorta, wherein the main module includes a generally tubular main stent-graft, which includes (a) a main generally tubular support element, which includes main structural stent elements, and (b) a main covering element that is attached to and at least partially covers the support element;

thereafter, transitioning the main stent-graft to a radially-expanded state thereof, in which the main covering element and the main support element are shaped so as to together define a lateral fenestration that is disposed in the aortic arch, with the lateral fenestration facing upstream generally toward an ascending aorta;

5 endovascularly introducing and passing a secondary module, while in a radially-compressed state thereof, through a distal portion of the main stent-graft such that the secondary module is disposed through the lateral fenestration and is disposed partially in the aortic arch, wherein the secondary module includes a non-bifurcated secondary stent-graft, which includes (a) a secondary support element, which includes secondary
10 structural stent elements, and (b) a secondary covering element that is attached to and partially covers the secondary support element; and

 thereafter, transitioning the secondary module to a radially-expanded state thereof, in which the secondary module is shaped so as to define (a) a proximal secondary-module end, (b) a sealing interface distal to the proximal secondary-module end, and (c) an
15 anchoring axial portion therebetween having a central longitudinal axis and an anchoring-portion length, measured along the central longitudinal axis from the distal sealing interface to the proximal secondary-module end, such that the sealing interface forms a blood-impervious seal with the lateral fenestration of the main module, the secondary covering element at least covers the secondary support element along a covered axial
20 portion of the anchoring axial portion, which covered axial portion extends proximally from the distal sealing interface for an axial covering distance equal to between 10% and 50% of the anchoring-portion length, the axial covering distance measured along the central longitudinal axis, wherein the secondary support element is uncovered proximally to the secondary covering element, and the anchoring axial portion has a greatest
25 anchoring-portion width that is (a) greater than a greatest proximal-end width at the proximal secondary-module end and (b) at least 20% greater than a greatest sealing-interface width at a narrowest portion of the distal sealing interface, the greatest anchoring-portion, sealing-interface, and proximal-end widths measured perpendicular to the central longitudinal axis.

30 The present invention will be more fully understood from the following detailed description of embodiments thereof, taken together with the drawings, in which:

BRIEF DESCRIPTION OF THE DRAWINGS

Fig. 1 is a schematic illustration of multi-component stent-graft system, in accordance with an application of the present invention;

5 Figs. 2A-B are schematic illustrations of a main module of the multi-component stent-graft system of Fig. 1, in accordance with respective applications of the present invention;

Fig. 3 is a schematic illustration of a secondary module of the multi-component stent-graft system of Fig. 1, in accordance with an application of the present invention;

10 Fig. 4 is a schematic illustration of another configuration of the secondary module of the multi-component stent-graft system of Fig. 1, in accordance with an application of the present invention;

Figs. 5 and 6 are schematic illustrations of alternative configurations of the secondary module of the multi-component stent-graft system of Fig. 1, in accordance with respective applications of the present invention;

15 Fig. 7 is a schematic illustration of yet another configuration of the secondary module of the secondary module of the multi-component stent-graft system of Fig. 1, in accordance with an application of the present invention;

Fig. 8 is a schematic illustration of yet another configuration of the secondary module of the secondary module of the multi-component stent-graft system of Fig. 1, in accordance with an application of the present invention;

20 Fig. 9 is a schematic illustration of still another configuration of the secondary module of the secondary module of the multi-component stent-graft system of Fig. 1, in accordance with an application of the present invention;

25 Fig. 10 is a schematic illustration of the secondary module of Fig. 9 deployed in an aortic arch, sealingly coupled to a lateral fenestration of a main module of the multi-component stent-graft system, in accordance with an application of the present invention;

Fig. 11 is a schematic illustration of another multi-component stent-graft system, in accordance with an application of the present invention;

Fig. 12 is a schematic illustration of a main module of the multi-component stent-graft system of Fig. 11, in accordance with an application of the present invention;

30 Figs. 13A and 13B are schematic illustrations of respective configurations of a

tertiary module of the multi-component stent-graft system of Fig. 11, in accordance with respective applications of the present invention;

Figs. 14A-B are schematic illustrations of kinking properties of different axial portions of a main stent-graft of the multi-component stent-graft system of Fig. 1, in accordance with an application of the present invention; and

Fig. 15 is a schematic illustration of kinking in a stent-graft.

DETAILED DESCRIPTION OF APPLICATIONS

Fig. 1 is a schematic illustration of multi-component stent-graft system 10, in accordance with an application of the present invention. In some applications of the present invention, multi-component stent-graft system 10 is provided for treating a Type B aortic dissection 12. The system is configured to be deployed in a thoracic aorta 14 and a left subclavian artery 16, and, optionally, a left common carotid artery 18. The multi-component stent-graft system is configured to be deployed in a straightforward procedure. The stent-grafts of the system are assembled in situ to accommodate the dimensions of the particular patient's anatomy, generally without requiring prior customization of the stent-grafts or in situ modifications to the stent-grafts, which might be expensive and/or complex.

Typically, upon deployment, the multi-component stent-graft system defines a blood-flow path from an ascending aorta 17, over an aortic arch 19, and to the descending aorta. The multi-component stent-graft system additionally provides or allows blood-flow paths to the three branches of the aortic arch.

Multi-component stent-graft system 10 comprises a main module 20 and, for some applications, a secondary module 22. Main module 20 comprises a generally tubular main stent-graft 24, and secondary module 22 comprises a non-bifurcated secondary stent-graft 26. The stent-grafts are configured to assume radially-compressed states, such as when initially positioned in one or more outer tubes of one or more delivery tools, and to assume radially-expanded states upon being deployed from the outer tube(s). Fig. 1 shows the stent-grafts in their radially-expanded states in situ. For some applications, the stent-grafts are relaxed in their radially-expanded states. For some applications, the stent-grafts are configured to be self-expanding. For example, they may be heat-set to assume their radially-expanded states.

Exemplary configuration of the main module

Reference is still made to Fig. 1, and is additionally made to Figs. 2A-B, which are schematic illustrations of main module 20 that comprises main stent-graft 24, in accordance with respective applications of the present invention. Figs. 2A-B show main stent-graft 24 unconstrained in its radially-expanded state, i.e., no forces are applied to the stent-graft by a delivery tool, walls of a blood vessel, or otherwise. Main stent-graft 24 typically comprises a main generally tubular support element 30 and a main covering element 32 that is attached to and at least partially covers (e.g., only partially covers) the main support element. Support element 30 typically comprises a plurality of main structural stent elements 31. For some applications, main structural stent elements 31 are arranged as a plurality of circumferential stent springs 33. For some applications, support element 30, as well as support elements 130, 230 and 330, which are described hereinbelow, comprise a super-elastic alloy, such as Nitinol. Main covering element 32 serves as a blood flow guide through at least a portion of the main stent-graft. Main covering element 32 typically comprises at least one biologically-compatible substantially blood-impervious flexible sheet, which is attached (such as by stitching) to at least a portion of the respective support element, on either side of the surfaces defined by the support element. The flexible sheet may comprise, for example, a polymeric material (e.g., a polyester, or polytetrafluoroethylene), a textile material (e.g., polyethylene terephthalate (PET)), natural tissue (e.g., saphenous vein or collagen), or a combination thereof.

Main covering element 32 and main support element 30 are shaped so as to together define a lateral fenestration 34, e.g., exactly one lateral fenestration 34, through main stent-graft 24, which lateral fenestration has distal and proximal fenestration ends 35 and 37, when main stent-graft 24 is unconstrained in its radially-expanded state. As used in the present application, including in the claims, a "fenestration" is an opening entirely surrounded by a covering element. For example, lateral opening 174, described hereinbelow with reference to Fig. 3, is not a fenestration, because the lateral opening extends from the end of module and thus is not surrounded by the covering element along a proximal edge of the lateral opening. When multi-component stent-graft system 10 is implanted as shown in Fig. 1, lateral fenestration 34 serves as an inferior lateral fenestration. Typically, at least a portion of the border of lateral fenestration 34 is defined by an undulating portion of one or more of structural stent elements 31.

For some applications, when main stent-graft 24 is unconstrained in its radially-expanded state, i.e., no forces are applied to the stent-graft by a delivery tool, walls of a blood vessel, or otherwise, a first perimeter P1 of a distal main-module end 36 of main stent-graft 24 (and main module 20) is greater than a second perimeter P2 of a proximal main-module end 38 of the main stent-graft (and the main module), and/or a first cross-sectional area of the distal main-module end 36 is greater than a second cross-sectional area of proximal main-module end 38. For applications in which main stent-graft 24 is generally cylindrical when unconstrained in its radially-expanded state, first and second perimeters P1 and P2 are first and second diameters. For example, first perimeter P1 may equal at least 150% of second perimeter P2, such as at least 200%, at least 250%, at least 300%, or at least 400%, and/or the first cross-sectional area may equal at least 225% of the second cross-sectional area, such as at least 400%, at least 625%, at least 900%, or at least 1600%.

For example, first perimeter P1 may be at least 5 cm, no more than 15 cm, and/or between 5 and 15 cm, such as at least 7.5 cm, e.g., at least 9 cm, no more than 13 cm, and/or between 7.5 (e.g., 9) and 13 cm, and second perimeter P2 may be at least 2.5 cm, no more than 5.7 cm, and/or between 2.5 and 5.7 cm, such as at least 3 cm, no more than 4.5 cm, and/or between 3 and 4.5 cm.

For some applications, when main stent-graft 24 is unconstrained in its radially-expanded state, a perimeter of lateral fenestration 34 is at least 5 cm, no more than 15 cm, and/or between 5 and 15 cm, such as at least 7.5 cm, e.g., at least 9 cm, no more than 13 cm, and/or between 7.5 cm (e.g., 9 cm) and 13 cm. For some applications, when main stent-graft 24 is unconstrained in its radially-expanded state, a perimeter of lateral fenestration 34 is at least 80%, no more than 120%, and/or between 80% and 120% of first perimeter P1, and/or at least 150%, no more than 250%, and/or between 150% and 250% of second perimeter P2.

For some applications, second module 22 is not necessary for providing blood flow into the lateral fenestration, and is thus optionally not provided. For example, second module 22 may not be necessary when lateral fenestration 34 is sufficiently large (e.g., has a perimeter of at least 9 cm and/or at least 80% of first perimeter P1).

For some applications, main stent-graft 24, when unconstrained in its radially-expanded state, has an axial length of at least 5 cm, no more than 40 cm, and/or between 5

and 30 cm, such as at least 10 cm, no more than 30 cm, and/or between 10 and 30 cm. (The axial length is measured along a central longitudinal axis 40 of the stent-graft.) For some applications, main stent-graft 24, when unconstrained in its radially-expanded state, has a greatest perimeter (at any axial location along the stent-graft) of at least 7.5 cm, no more than 19 cm, and/or between 7.5 and 19 cm, such as at least 12.5 cm, no more than 16 cm, and/or between 12.5 and 16 cm. These values are typical for adult subjects, in which the vast majority of dissections occur. For pediatric subjects, in which dissections are rare, these dimensions may be reduced by a factor of up to 1:3.

For some applications, such dimensions allow main stent-graft 24 to be positioned such that (a) a distal, radially larger, descending-aorta axial portion 42 of the stent-graft, including distal main-module end 36 thereof, is disposed in the aorta downstream from the bifurcation with the left subclavian artery, at least partially in the upper part of the descending aorta, (b) a proximal, radially smaller, supra-arch axial portion 44 of the main stent-graft, including proximal main-module end 38 thereof, is disposed in left subclavian artery 16, as shown in Fig. 1, and (c) an arch axial portion 46, axially between descending-aorta axial portion 42 and supra-arch axial portion 44, is disposed in aortic arch 19. Typically, arch axial portion 46 at least partially axially overlaps fenestration 34, since the fenestration should be disposed in the apex of the arch. For some applications, descending-aorta axial portion 42 has an average perimeter that is greater than (e.g., between 5% and 15% greater than) an average perimeter of the portion of the aorta in which it is disposed. For some applications, supra-arch axial portion 44 has an average perimeter that is greater than (e.g., between 5% and 15% greater than) the average perimeter of the portion of the left subclavian artery in which it is disposed.

For some applications, when main stent-graft 24 is unconstrained in its radially-expanded state, the main stent-graft includes a dissection-reinforcement axial portion 48, which:

- includes a portion of main structural stent elements 31;
- has a distal dissection-reinforcement end 50;
- has a proximal dissection-reinforcement end 52 that is disposed along the stent-graft no more than 20 mm proximal to proximal fenestration end 37; proximal dissection-reinforcement end 52 may be either proximal or distal to proximal fenestration end 37. For some applications, proximal dissection-

reinforcement end 52 is disposed along the main stent-graft no more proximal than distal fenestration end 35 when the stent-graft is unconstrained in the radially-expanded state, such as shown in Figs. 1 and 2A. For other applications, proximal dissection-reinforcement end 52 is disposed along the main stent-graft between distal fenestration end 35 and proximal fenestration end 37, inclusive, when the stent-graft is unconstrained in the radially-expanded state, such as shown in Fig. 2B; and/or

- extends along the stent-graft for a distance equal to at least 5%, no more than 32%, and/or between 5% and 32% of a greatest perimeter of the stent-graft distally to distal fenestration end 35, such as at least 10%, no more than 20%, and/or between 10% and 20%.

For some applications, dissection-reinforcement axial portion 48 has a radial strength that is at least 10% greater than an average radial strength of the entire main stent-graft, such as at least 15% greater, or at least 30% greater. This greater strength increases the force that dissection-reinforcement axial portion 48 applies to a tear 56 of aortic dissection 12, thereby sealing the tear. Tear 56 is generally located in an upper portion of thoracic aorta 14, and sometimes additionally in a lower portion of left subclavian artery 16 and/or at the take-off of left subclavian artery 16 from thoracic aorta 14. (It is noted that providing the entire length of the main stent-graft with a high strength has at least two drawbacks: stent-grafts with higher strengths are more difficult to deploy, and are more likely to cause damage to the vasculature.)

Typically, an arch axial portion 46 and dissection-reinforcement axial portion 48 do not include any bare main structural stent elements 31, such that main covering element 32 intervenes between the stent elements and the blood vessel wall in the vicinity of tear 56.

For some applications, an axial length of dissection-reinforcement axial portion 48 is at least 1 cm, no more than 3 cm, and/or between 1 and 3 cm when the main stent-graft is unconstrained in the radially-expanded state.

For some applications, a distance D1 between distal dissection-reinforcement end 50 and distal main-module end 36 is at least 32%, no more than 160%, and/or between 32% and 160% of a largest perimeter of the main stent-graft, when the main stent-graft is unconstrained in the radially-expanded state. Alternatively or additionally, for some

applications, distance D1 is at least 3 cm, no more than 5 cm, and/or between 3 and 5 cm, when the main stent-graft is unconstrained in the radially-expanded state. Still further alternatively or additionally, for some applications, when the main stent-graft is unconstrained in the radially-expanded state: (a) distance D1 equals between at least 20%,
5 no more than 66%, and/or between 20% and 66% of a total length L1 of main stent-graft 24, and/or (b) a distance D2 between proximal dissection-reinforcement end 52 and proximal main-module end 38 equals at least 33%, no more than 80%, and/or between 33% and 80% of total length L1.

For some applications, such as shown in Figs. 2A-B, dissection-reinforcement
10 axial portion 48 is configured to be generally straight when the main stent-graft is unconstrained in the radially-expanded state.

For some applications, main structural stent elements 31 of dissection-reinforcement axial portion 48 are arranged as a plurality of circumferential stent springs 33 of dissection-reinforcement axial portion 48. For some applications, a strut height H,
15 measured axially along the main stent-graft, of at least one of stent springs 33 of dissection-reinforcement axial portion 48 varies by less than 10% around a circumference of the stent spring when the main stent-graft is unconstrained in the radially-expanded state. For some applications, for each one of stent springs 33 of dissection-reinforcement axial portion 48, height H of the stent spring varies by less than 10% around a
20 circumference of the stent spring when the main stent-graft is unconstrained in the radially-expanded state.

For some applications, the portion of structural stent elements 31 included by dissection-reinforcement axial portion 48 is a first portion of structural stent elements 31, and when the stent-graft is unconstrained in the radially-expanded state: (a) main stent-graft 24 includes a distal-end axial portion 54, which includes a second portion of
25 structural stent elements 31, (b) distal-end axial portion 54 axially extends along the stent-graft from distal main-module end 36 for a distance equal to at least 5%, no more than 32%, and/or between 5% and 32% of a greatest perimeter of the main stent-graft distally to distal fenestration end 35, such as at least 11%, no more than 22%, and/or between
30 11% and 22%, and (c) distal-end axial portion 54 has a radial strength that is at least a 10% greater than the average radial strength of the entire main stent-graft.

For some applications, dissection-reinforcement axial portion 48 includes a first

plurality 60 of stent springs 33, and main stent-graft 24 includes a distal axial portion 58, which includes a second plurality 62 of stent springs 33. Distal axial portion 58 is disposed along the main stent-graft distal and axially adjacent to distal dissection-reinforcement end 50, and extends along the main stent-graft for a distance equal to at least 5%, no more than 32%, and/or between 5% and 32% of the greatest perimeter of the main stent-graft distally to the distal fenestration end 35. Typically, distal axial portion 58 extends to and reaches the distal main-module end 36. Stent springs 33 have respective average strut heights, measured axially along the main stent-graft (the height of each stent spring is averaged circumferentially around the stent-graft). An average of the average heights of first plurality 60 of stent springs 33 is less than 75% (e.g., less than 70%) of the average height of a proximal-most one 64 of second plurality 62 of stent springs 33. These smaller average heights generally allow dissection-reinforcement axial portion 48 to bend without the stent springs thereof coming into contact with one another. For these applications, dissection-reinforcement axial portion 48 is typically configured to be generally straight when the main stent-graft is unconstrained in the radially-expanded state.

For some applications, each of the average heights of first plurality 60 of stent springs 33 is less than 75% (e.g., less than 70%) of the average height of proximal-most one 64 of second plurality 62 of stent springs 33 when the main stent-graft is unconstrained in the radially-expanded state. For some applications, the average of the average heights of first plurality 60 of stent springs 33 is less than 75% (e.g., less than 70%) of the average height of a second one 66 of second plurality 62 of stent springs 33, other than proximal-most one 64 of second plurality 62 of stent springs 33 when the main stent-graft is unconstrained in the radially-expanded state. For some applications, the average of the average heights of first plurality 60 of stent springs 33 is less than 75% (e.g., less than 70%) of each of the average heights of second plurality 62 of stent springs 33 when the main stent-graft is unconstrained in the radially-expanded state.

For some applications, an axial spacing S between two of first plurality 60 of stent springs 33 of dissection-reinforcement axial portion 48 equals less than 10% of an average of the average heights H of the two stent springs 33. Such low axial spacing between the stent springs of reduces the risk of kinking of dissection-reinforcement axial portion 48. The use of a greater axial spacing S would make dissection-reinforcement axial portion 48 more prone to kinking, such as described hereinbelow with reference to

Fig. 14.

For some applications, distal axial portion 58 is configured to be generally straight when the main stent-graft is unconstrained in the radially-expanded state.

Exemplary configuration of the secondary module

5 Reference is still made to Fig. 1, and is additionally made to Fig. 3, which is a schematic illustration of secondary module 22 that comprises secondary stent-graft 26, in accordance with an application of the present invention. Fig. 3 shows secondary stent-graft 26 unconstrained in its radially-expanded state, i.e., no forces are applied to the stent-graft by a delivery tool, walls of a blood vessel, or otherwise. Secondary stent-graft
10 26 typically comprises a secondary generally tubular support element 130 and a secondary covering element 132 that is attached to and at least partially covers (e.g., only partially covers) the secondary support element. Support element 130 typically comprises a plurality of secondary structural stent elements 131. For some applications, secondary structural stent elements 131 are arranged as a plurality of circumferential stent springs
15 133. Secondary covering element 132 serves as a blood flow guide through at least a portion of the secondary stent-graft. Secondary covering element 132 typically comprises at least one biologically-compatible substantially blood-impervious flexible sheet, which is attached (such as by stitching) to at least a portion of the respective support element, on either side of the surfaces defined by the support element. The flexible sheet may
20 comprise, for example, a polymeric material (e.g., a polyester, or polytetrafluoroethylene), a textile material (e.g., polyethylene terephthalate (PET)), natural tissue (e.g., saphenous vein or collagen), or a combination thereof.

When secondary module 22 (and secondary stent-graft 26) is unconstrained in the radially-expanded state thereof:

- 25 • secondary module 22 is shaped so as to define a proximal secondary-module end 138, a sealing interface 172 distal to proximal secondary-module end 138, and a central longitudinal axis 140 therebetween. Sealing interface 172 is sized and configured to form a blood-impervious seal with lateral fenestration 34 of main module 20;
- 30 • secondary module 22 is shaped so as to define a distal secondary-module end 136; and

- secondary covering element 132 is shaped so as to define at least one lateral opening 174 that begins at and extends from proximal secondary-module end 138 toward sealing interface 172 along central longitudinal axis 140 for a distance D3 equal to at least 50% (e.g., at least 70%) of a greatest width W1 of secondary module 22, measured perpendicular to central longitudinal axis 140. In other words, lateral opening 174 reaches proximal secondary-module end 138, is thus not entirely surrounded by secondary covering element 132, and therefore is not a fenestration, as defined hereinabove with reference to Figs. 1 and 2A-B.

For some applications, a greatest width W2 of at least one lateral opening 174, measured circumferentially around secondary module 22, equals at least 90 degrees circumferentially around proximal secondary-module end 138, the 90 degrees being measured at sealing interface 172 (even though the lateral opening typically does not extend to the sealing interface, and may have its greatest width W2 at proximal secondary-module end 138).

For some applications, at least one of secondary structural stent elements 131 traverses lateral opening 174 when the secondary module is unconstrained in the radially-expanded state thereof. By way of example, in Fig. 3 two secondary structural stent elements 131B are shown traversing lateral opening 174. Alternatively, a single secondary structural stent element 131B, or three or more secondary structural stent elements 131B, traverse lateral opening 174. Such traversal may provide additional structural strength to secondary module 22 at the lateral opening. For some applications of this configuration, support element 130 is shaped so as to define a complete tube, which is only partially covered by secondary covering element 132. For some other applications in which none of secondary structural stent elements 131 traverses lateral opening 174, support element 130 is shaped so as to define a partial tube circumferentially.

For some applications, a cross-sectional area of secondary module 22, measured perpendicular to central longitudinal axis 40, gradually tapers from proximal secondary-module end 138 to sealing interface 172 when the secondary module is unconstrained in the radially-expanded state thereof.

For some applications, such as shown in Fig. 3, the at least one lateral opening 174

comprises exactly one lateral opening 174. For some of these applications, when secondary module 22 is unconstrained in the radially-expanded state thereof, lateral opening 174 faces in a first radial direction extending from central longitudinal axis 140, and a portion 176 of secondary covering element 132 that faces in a second radial direction opposite the first radial direction extends to and reaches proximal secondary-module end 138. In other words, secondary module 22 is covered by secondary covering element 132 on the side circumferentially opposite lateral opening 174, such that lateral opening 174 and portion 176 face in radially-opposite directions.

Typically, upon deployment of main and secondary stent-grafts 20 and 22, the stent-grafts together provide continuous coverage covering element material along the blood flow path, which may help prevent further trauma to aorta, and sub-tears in the aorta.

Exemplary deployment of the multi-component stent-graft system

Reference is again made to Fig. 1, which schematically shows a portion of a typical aorta, including thoracic aorta 14, which includes an upper part of ascending aorta 17, and aortic arch 19, and an upper part of a supra-renal descending aorta. Also shown are the three branches of aortic arch 19: a brachiocephalic artery 70, left common carotid artery 18, and left subclavian artery 16.

In an exemplary transluminal delivery procedure for implanting multi-component stent-graft system 10, as configured in Figs. 1 and 2A-B, the stent-grafts of system 10 are endovascularly (typically percutaneously) introduced into the thoracic aorta, such as via one of the iliac arteries, while the stent-grafts are positioned in one or more outer tubes of a delivery tool in their radially-compressed states.

Typically, the exemplary procedure begins with the advancing of a guidewire up the descending aorta and into left subclavian artery 16. Main stent-graft 24 of main module 20 is initially positioned in its radially-compressed state within an outer tube of a delivery tool, typically near a leading end of the outer tube. The outer tube is advanced over the guidewire, until main stent-graft 24 is partially disposed in left subclavian artery 16 and partially disposed in the upper part of the descending aorta. The guidewire is withdrawn, leaving the outer tube in place. The main stent-graft is held in place as the

outer tube is withdrawn, thereby delivering the main stent-graft from the outer tube. Main stent-graft 24 typically self-expands, until it assumes its radially-expanded state, upon reaching typically about 80-90% of its maximum unconstrained size, and/or being constrained from further expansion by the wall of the blood vessels, as shown in Fig. 1.

5 Alternatively, the main stent-graft (and/or the other stent-grafts, as described hereinbelow) is delivered using an over-the-wire (OTW) approach, in which the guidewire is left in place until the stent-graft is expanded, and thereafter the guidewire is withdrawn.

Descending-aorta axial portion 42 of main stent-graft 24, including distal main-module end 36, is positioned in the upper part of the descending aorta, and supra-arch axial portion 44 of main stent-graft 24, including proximal main-module end 38, is positioned in left subclavian artery 16. Arch axial portion 46 of main stent-graft 24, including lateral fenestration 34, is disposed in aortic arch 19, with the lateral fenestration facing upstream, generally toward ascending aorta 17, in a vicinity of the bifurcation of aortic arch 19 and left subclavian artery 16. For some applications, proper rotational alignment and/or axial orientation of the lateral fenestration is achieved using fluoroscopy. For example, main stent-graft 24 may comprise one or more radiopaque markers in a vicinity of (e.g., on a periphery of) the lateral fenestration.

10
15

A guidewire (either the same guidewire used to deploy the main stent-graft, or a second guidewire) is advanced up the descending aorta, through a distal portion of main stent-graft 24, out of lateral fenestration 34, and into aortic arch 19, extending toward, or partially into, ascending aorta 17. Secondary stent-graft 26 of secondary module 22 is positioned in its radially-compressed state within an outer tube of a delivery tool (either the same outer tube used to deploy the main stent-graft, or a second outer tube), typically near a leading end of the outer tube. The outer tube is advanced over the guidewire, until secondary stent-graft 26 is partially disposed in aortic arch 19, extending toward, or partially into, ascending aorta 17, and partially disposed within radially-expanded main stent-graft 24 in the upper part of the descending aorta. The guidewire is withdrawn, leaving the outer tube in place.

20
25

The secondary stent-graft is rotationally aligned such that the at least one lateral opening 174 faces left common carotid artery 18, so as to allow blood flow to the left common carotid artery (and, for applications in which the secondary stent-graft is long enough, so as to allow blood flow into brachiocephalic artery 70). The secondary stent-

30

graft may comprise one or more radiopaque markers to facilitate such proper rotational alignment. For example, the radiopaque markers may be positioned on one or more edges of the at least one lateral opening. Secondary module 22 is positioned so as to not block brachiocephalic artery 70 or left common carotid artery 18.

5 The secondary stent-graft is held in place as the outer tube is withdrawn, thereby delivering the secondary stent-graft from the outer tube. Secondary stent-graft 26 typically self-expands, until it assumes its radially-expanded state, upon reaching its maximum unconstrained size, and/or being constrained from further expansion by the wall of the blood vessels. Secondary stent-graft 26 is thus adapted for transluminal
10 delivery in its radially-compressed state through a portion of main stent-graft 24 and lateral fenestration 34, while the main stent-graft is in its radially-expanded state.

A distal portion of secondary stent-graft 26, including distal secondary-module end 136, is positioned within main stent-graft 24, and sealing interface 172 of secondary stent-graft 26 is sealingly coupled to lateral fenestration 34 of main stent-graft 24. A
15 proximal portion of secondary stent-graft 26, including proximal end 138, is positioned in aortic arch 19. As mentioned, the at least one lateral opening 174 faces left common carotid artery 18. Secondary module 22 reduces blood turbulence in the aortic arch, and serves as a funnel that creates a gradual taper of the blood flow into lateral fenestration 34 of main stent-graft 24.

20 For some applications, main and secondary stent-grafts 24 and 26, when in their respective radially-expanded states, constrained by the respective blood vessels in which they are positioned, have some or all of the dimensional and/or strength characteristics described herein as applicable when the stent-grafts are unconstrained in their radially-expanded states. By way of example and not limitation, (a) first perimeter P1 of distal
25 main-module end 36 of main stent-graft 24 may equal at least 200% (e.g., at least 250%, at least 300%, or at least 400%) of second perimeter P2 of proximal main-module end 38 of the main stent-graft, (b) proximal dissection-reinforcement end 52 may be disposed along the main stent-graft no more than 20 mm proximal to proximal fenestration end 37, (c) dissection-reinforcement axial portion 48 may extend along the main stent-graft for a
30 distance equal to between 5% and 32% of the greatest perimeter of the main stent-graft distally to distal fenestration end 35, and/or dissection-reinforcement axial portion 48 may have a radial strength that is at least 10% greater than an average radial strength of the

entire main stent-graft.

Alternative configurations of the secondary module

Reference is now made to Fig. 4, which is a schematic illustration of another configuration of secondary module 22, in accordance with an application of the present invention. In this configuration, when secondary module 22 is unconstrained in the radially-expanded state thereof:

- the at least one lateral opening 174 includes at least first and second lateral openings 174A and 174B;
- secondary covering element 132 is shaped so as to define first and second lateral openings 174A and 174B, each of which begins at and extends from proximal secondary-module end 138 toward sealing interface 172 along central longitudinal axis 140 for distance D3 equal to at least 50% of greatest width W1 of secondary module 22;
- first and second lateral openings 174A and 174B face in different first and second radial directions extending from central longitudinal axis 140; and
- first and second lateral openings 174A and 174B at least partially axially overlap along central longitudinal axis 140.

For some applications, such as shown in Fig. 4, first and second lateral openings 174A and 174B axially coincide along central longitudinal axis 140. For some applications, such as shown in Fig. 4, the first and the second radial directions are opposite each other; in other words first and second lateral openings 174A and 174B face in radially-opposite directions.

For some applications, such as shown in Fig. 4, secondary covering element 132 is shaped so as to define two portions 176A and 176B, which (a) extend to and reach proximal secondary-module end 138, and (b) are shaped so as to define respective concave inner surfaces 178A and 178B that face each other and central longitudinal axis 140, and (c) are not joined to each other at proximal secondary-module end 138.

During deployment of secondary module 20 in aortic arch 19, such as described hereinabove with reference to Fig. 1, the secondary module is rotationally aligned such that one of first and second lateral openings 174A and 174B faces left common carotid

artery 18, so as to allow blood flow into the left common carotid artery (and, for applications in which the secondary stent-graft is long enough, so as to allow blood flow into brachiocephalic artery 70). The other of the lateral openings faces downward toward the wall of aortic arch 19 opposite the left common carotid artery, and may serve to prevent blood from becoming trapped below the bottom side of the secondary module, which might cause blood coagulation.

Reference is now made to Figs. 5 and 6, which are schematic illustrations of alternative configurations of secondary module 22, in accordance with respective applications of the present invention. In these configurations, when secondary module 22 is unconstrained in the radially-expanded state thereof:

- secondary module 22 is shaped so as to define proximal secondary-module end 138, sealing interface 172, and central longitudinal axis 140 therebetween. Sealing interface 172 is sized and configured to form a blood-impervious seal with lateral fenestration 34 of main module 20;
- secondary module 22 is shaped so as to define distal secondary-module end 136;
- secondary covering element 132 is shaped so as to define at least one secondary-module lateral fenestration 134 disposed distal to proximal secondary-module end 138 and proximal to sealing interface 172, and
- a greatest axial length L2 of secondary-module lateral fenestration 134, measured parallel to central longitudinal axis 140, equals at least 33% (e.g., at least 50%) of first perimeter P1 of distal main-module end 36 of main stent-graft 24 of main module 20, when the main module is unconstrained in the radially-expanded state thereof.

For some applications, a greatest width W3 of secondary-module lateral fenestration 134, measured circumferentially around secondary module 22, equals at least 16% of first perimeter P1, such as at least 25% of first perimeter P1. These dimensions of greatest axial length L2 and greatest width W3 may allow secondary-module lateral fenestration 134 to allow sufficient blood flow to both left common carotid artery 18 and brachiocephalic artery 70.

Because secondary-module lateral fenestration 134 does not reach proximal

secondary-module end 138, secondary covering element 132 is shaped so as to define an additional fixation zone 184 between secondary-module lateral fenestration 134 and proximal secondary-module end 138.

For some applications, at least one of secondary structural stent elements 131
5 traverses secondary-module lateral fenestration 134 when secondary module 22 is unconstrained in the radially-expanded state thereof. By way of example, in Fig. 5 one secondary structural stent element 131B is shown traversing secondary-module lateral fenestration 134, and in Fig. 6 two secondary structural stent elements 131B are shown traversing secondary-module lateral fenestration 134. Alternatively, three or more
10 secondary structural stent elements 131B traverse secondary-module lateral fenestration 134. Such traversal may provide additional structural strength to secondary module 22 at the secondary-module lateral fenestration.

Typically, at least a portion of the border of secondary-module lateral fenestration 134 is defined by an undulating portion of one or more of secondary structural stent
15 elements 131.

For some applications, a cross-sectional area of secondary module 22 gradually tapers from proximal secondary-module end 138 to sealing interface 172 when the secondary module is unconstrained in the radially-expanded state thereof.

For some applications, such as shown in Fig. 5, the at least one secondary-module
20 lateral fenestration 134 comprises exactly one secondary-module lateral fenestration 134. For some of these applications, when secondary module 22 is unconstrained in the radially-expanded state thereof, secondary-module lateral fenestration 134 faces in a first radial direction extending from central longitudinal axis 140, and a portion 182 of secondary covering element 132 that faces in a second radial direction opposite the first
25 radial direction extends to and reaches proximal secondary-module end 138. In other words, secondary module 22 is covered by secondary covering element 132 on the side circumferentially opposite secondary-module lateral fenestration 134, such that secondary-module lateral fenestration 134 and portion 182 face in radially-opposite directions.

30 During deployment of secondary module 20 in aortic arch 19, such as described hereinabove with reference to Fig. 1, the secondary module is rotationally aligned such that secondary-module lateral fenestration 134 faces left common carotid artery 18, so as

to allow blood flow into the left common carotid artery.

Reference is made to Fig. 6. For some applications, secondary module 22 further comprises a flexible sheet 190, which (a) is blood-sealingly joined to a portion of a secondary border 180 of secondary-module lateral fenestration 134, which portion
5 extends around at least 25% of a perimeter of the secondary border and includes a distal end 192 of secondary border 180 when secondary module 22 is unconstrained in the radially-expanded state thereof, and (b) extends radially inward from secondary border 180 (toward or past central longitudinal axis 140) when secondary module 22 is unconstrained in the radially-expanded state thereof. For some applications, a portion 194
10 of secondary structural stent elements 131 are attached to flexible sheet 190, which facilitates the radially-inward extension of flexible sheet 190 from secondary border 180.

As mentioned above, during deployment of secondary module 20 in aortic arch 19, such as described hereinabove with reference to Fig. 1, the secondary module is rotationally aligned such that secondary-module lateral fenestration 134 faces left
15 common carotid artery 18. Flexible sheet 190 serves to direct a portion of the blood flow into the left common carotid artery.

Reference is now made to Fig. 7, which is a schematic illustration of yet another configuration of secondary module 22, in accordance with an application of the present invention. In this configuration, secondary module 22 is shaped so as to define proximal
20 secondary-module end 138, sealing interface 172, and an anchoring axial portion 160 therebetween having central longitudinal axis 140 and an anchoring-portion length L3, measured along the central longitudinal axis from distal sealing interface 172 to proximal secondary-module end 138. Anchoring axial portion 160 is typically configured to (a) accommodate the anatomy of aortic arch 19 without blocking blood flow in the arch or to
25 left common carotid artery 18 or brachiocephalic artery 70, (b) provide support for anchoring the secondary module in the aortic arch, and/or (c) provide support for secondary covering element 132, as described below.

Anchoring axial portion 160 includes a plurality (e.g., at least 8) of secondary structural stent elements 131, which, for example may comprise respective wires. For
30 some applications, each of plurality of secondary structural stent elements 131 has two longitudinal portions 168 that extend toward (e.g., reach) distal sealing interface 172, and an intermediary longitudinal portion 170 that curves around proximal secondary-module

end 136, when secondary module 22 is unconstrained in the radially-expanded state thereof (by way of example, one of such secondary structural stent elements 131 is labeled with reference numeral 167 in Fig. 7). Curved portions 170 of the plurality of secondary structural stent elements 131 may or may not converge at a single point at proximal secondary-module end 136. For some applications, the plurality of secondary structural stent elements 131 of anchoring axial portion 160 includes some structural stent elements that touch one another (e.g. at or near proximal secondary-module end 138), and no structural stent elements that are fixed to one another, when the secondary module is unconstrained in the radially-expanded state thereof.

10 For some applications, secondary structural stent elements 131 may include a loop element, e.g. a polygonal or elliptical (e.g., circular) loop, at proximal secondary-module end 136, to which loop element respective ends of the plurality of secondary structural stent elements 131 are coupled (configuration not shown).

In this configuration, when secondary module 22 is unconstrained in the radially-expanded state thereof, secondary covering element 132 at least covers secondary support element 130 along a covered axial portion 162 of anchoring axial portion 160. Secondary structural stent elements 131 of anchoring axial portion 160 provide support for secondary covering element 132, holding the secondary covering element open so as to facilitate blood flow to sealing interface 172 and through lateral fenestration 34 of main stent-graft 24.

Covered axial portion 162 extends proximally from distal sealing interface 172 for an axial covering distance D_4 equal to at least 10% (e.g., at least 15%, such as at least 20%), no more than 50% (e.g., no more than 35%), and/or between 10% and 50% (e.g., between 10% and 35%, or between 20% and 35%) of anchoring-portion length L_3 , axial covering distance D_4 measured along central longitudinal axis 140, when secondary module 22 is unconstrained in the radially-expanded state thereof. Secondary support element 130 is uncovered proximally to secondary covering element 132. When secondary module 22 is unconstrained in the radially-expanded state thereof, an uncovered axial portion 163 of anchoring axial portion 160 extends from proximal secondary-module end 138 to a proximal end 165 of covered axial portion 162, for an axial uncovered distance D_7 equal to at least 50% (e.g., at least 65%), no more than 90% (e.g., no more than 80%), and/or between 50% and 90% (e.g., between 65% and 80%) of

anchoring-portion length L3, measured along central longitudinal axis 140.

Typically, when secondary module 22 is unconstrained in the radially-expanded state thereof, anchoring axial portion 160 has a greatest anchoring-portion width W4 that is (a) greater than a greatest proximal-end width W5 at the proximal secondary-module end (W5 is optionally zero, as shown, for configurations in which the plurality of secondary structural stent elements 131 converge at a single point) and (b) at least 20%, e.g., at least 50%, at least 75%, or at least 100%, greater than a greatest sealing-interface width W6 at a narrowest portion 164 of distal sealing interface 172, greatest anchoring-portion, sealing-interface, and proximal-end widths W4, W5, and W6 measured perpendicular to central longitudinal axis 140. For some applications, anchoring axial portion 160 has greatest anchoring-portion width W4 at an axial location 166 at an axial distance D5 from proximal secondary-module end 138 equal to at least 33%, no more than 60%, and/or between 33% and 60% of anchoring-portion length L3, axial distance D5 measured along central longitudinal axis 140, when secondary module 22 is unconstrained in the radially-expanded state thereof.

For some applications, axial covering distance D4 from distal sealing interface 172 is equal to at least 20% (e.g., at least 30%), no more than 100% (e.g., no more than 60%), and/or between 20% and 100% (e.g., between 30% and 60%) of an axial distance D6 between distal sealing interface 172 and axial location 166 of greatest anchoring-portion width W4, axial distance D6 measured along central longitudinal axis 140, when secondary module 22 is unconstrained in the radially-expanded state thereof.

For some applications, when secondary module 22 is unconstrained in the radially-expanded state thereof:

- anchoring-portion length L3 equals at least 50 mm, no more than 150 mm, and/or between 50 and 150 mm;
- greatest width W4 equals at least 30 mm, no more than 60 mm, and/or between 30 and 60 mm;
- greatest proximal-end width W5 equals at least 0 mm, no more than 35 mm, and/or between 0 and 35 mm, and/or at least 0 mm, no more than 40% of W4, and/or between 0 mm and 40% of W4;
- greatest sealing-interface width W6 equals at least 25 mm, no more than 40

mm, and/or between 25 and 40 mm;

- axial covering distance D4 equals at least 10 mm, no more than 30 mm, and/or between 10 and 30 mm;
- 5 • axial distance D5 equals at least 20 mm, no more than 80 mm, and/or between 20 and 80 mm;
- axial distance D6 equals at least 30 mm, no more than 80 mm, and/or between 30 and 80 mm; and/or
- axial uncovered distance D7 equals at least 30 mm, no more than 120 mm, and/or between 30 and 120 mm.

10 Reference is now made to Fig. 8, which is a schematic illustration of yet another configuration of secondary module 22, in accordance with an application of the present invention. Fig. 8 shows secondary module 22 deployed in aortic arch 19, sealingly coupled to lateral fenestration 34 of main module 20. In this configuration, secondary covering element 132 is shaped so as to define at least one lateral opening 174 that begins
15 at and extends from proximal secondary-module end 138 toward sealing interface 172, such as described hereinabove with reference to Figs. 3 and 4. Alternatively, the configuration of Fig. 8 may be implemented in combination with the configurations described hereinabove with reference to Figs. 5, 6, and/or 7.

20 In this configuration, secondary module 22 comprises an extension structure 200, which is disposed radially outward of a fluid-flow path defined by secondary module 22, in a same radially direction as one of the at least one lateral opening of secondary covering element 132 (in the case of the configuration shown in Figs. 3 and 4, at least one lateral opening 174, and in the case of Fig. 5 and 6, at least one secondary-module lateral fenestration 134). Extension structure 200 typically comprises one or more of secondary
25 structural stent elements 131. Extension structure 200 is shaped so as to help hold secondary module 22 properly positioned in aortic arch 19.

For some applications, at least one of secondary structural stent elements 131 traverses the lateral opening when the secondary module is unconstrained in the radially-expanded state thereof, and extension structure 200 is coupled to the lateral opening.

30 Reference is now made to Figs. 9 and 10, which are schematic illustrations of a secondary module 222, in accordance with an application of the present invention. Fig. 9

shows secondary module 222, and Fig. 10 shows secondary module 222 deployed in aortic arch 19, sealingly coupled to lateral fenestration 34 of main module 20. Fig. 9 shows secondary module 222 unconstrained in its radially-expanded state, i.e., no forces are applied to the module by a delivery tool, walls of a blood vessel, or otherwise.

5 Secondary module 222 comprises a non-bifurcated secondary stent-graft 226, which typically comprises a secondary generally tubular support element 230 and a secondary covering element 232 that is attached to and at least partially covers a covered axial portion 242 of support element 230 and at least partially does not cover an
10 covering element 232 partially covers an overlap axial portion 246 along which first and second axial portions 244 and 246 axially overlap; for example, a distal end 250 of secondary covering element 232 may be generally diagonally-shaped, such as shown in Fig. 9.

 Support element 230 typically comprises a plurality of secondary structural stent
15 elements 231. For some applications, secondary structural stent elements 231 are arranged as a plurality of circumferential stent springs 233. Secondary covering element 232 serves as a blood flow guide through at least a portion of the secondary stent-graft. Secondary covering element 232 typically comprises at least one biologically-compatible substantially blood-impervious flexible sheet, which is attached (such as by stitching) to
20 at least a portion of the respective support element, on either side of the surfaces defined by the support element. The flexible sheet may comprise, for example, a polymeric material (e.g., a polyester, or polytetrafluoroethylene), a textile material (e.g., polyethylene terephthalate (PET)), natural tissue (e.g., saphenous vein or collagen), or a combination thereof.

25 As shown in Fig. 10, secondary module 222 is configured to be partially inserted into main module 20, such that uncovered axial portion 244 is positioned within main module 20, and covered axial portion 242 is partially positioned outside of and partially positioned within main module 20, through lateral fenestration 34. A portion of secondary covering element 232 passes through lateral fenestration 34, so as to form a
30 blood-tight seal with main module 20. The portion of covered axial portion 242 positioned outside of main module 20 is short enough so as to not block blood flow left common carotid artery 18 or brachiocephalic artery 70.

Reference is now made to Figs. 11, 12, and 13A-B. Fig. 11 is a schematic illustration of a multi-component stent-graft system 310, in accordance with an application of the present invention. Multi-component stent-graft system 310 comprises a main module 320, a secondary module 322, and typically a tertiary module 328, which
5 comprise respective stent-grafts, as described below. The stent-grafts are configured to assume radially-compressed states, such as when initially positioned in one or more outer tubes of one or more delivery tools, and to assume radially-expanded states upon being deployed from the outer tube(s). Fig. 11 shows the stent-grafts in their radially-expanded states in situ.

10 Fig. 12 is a schematic illustration of main module 320, in accordance with an application of the present invention. Fig. 12 shows main stent-graft 24 unconstrained in its radially-expanded state, i.e., no forces are applied to the stent-graft by a delivery tool, walls of a blood vessel, or otherwise. Other than as described hereinbelow, main module 320 may implement any or all of the features of main module 20, described hereinabove
15 with reference to Figs. 1 and 2A-B, including, but not limited to, dissection-reinforcement axial portion 48, descending-aorta axial portion 42, supra-arch axial portion 44, arch axial portion 46, and/or distal axial portion 58. Main module 320 comprises a generally tubular main stent-graft 324, such as described hereinabove with reference to Figs. 2A-B regarding main stent-graft 24.

20 Unlike stent-graft 24, main covering element 32 and main support element 30 of main stent-graft 324 are shaped so as to together define two lateral fenestrations through main stent-graft 324: a first lateral fenestration 34, as defined by stent-graft 24, and a second lateral fenestration 368, when main stent-graft 324 is unconstrained in its radially-expanded state. Typically, when main stent-graft 324 is unconstrained in its radially-
25 expanded state, first lateral fenestration 34 faces in a first radial direction, and second lateral fenestration 368 faces in a second radially direction generally circumferentially opposite the first radial direction. For example, if the stent-graft is viewed from one end, the first lateral fenestration may be disposed at between 11 o'clock and 1 o'clock (e.g., at 12 o'clock), and the second lateral fenestration may be disposed at between 5 o'clock and 7
30 o'clock (e.g., at 6 o'clock).

When multi-component stent-graft system 310 is implanted as shown in Fig. 11, first lateral fenestration 34 serves as an inferior lateral fenestration, and second lateral

fenestration 368 serves as a superior lateral fenestration.

Typically, a first perimeter of first (inferior) lateral fenestration 34 equals at least 200%, no more than 400%, and/or between 200% and 400% of a second perimeter of second (superior) lateral fenestration 368.

5 For some applications, supra-arch axial portion 44 of main stent-graft 324 is internally lined with ePTFE film, or main covering element 32 of main stent-graft 324 comprises entirely ePTFE (and thus does not comprise any polyester). Optionally, main covering element 32 along other portions of the main stent-graft comprises polyester. (This configuration may also be implemented in main stent-graft 24, described
10 hereinabove with reference to Figs. 1 and 2A-B.)

Other than as described hereinbelow, secondary module 320 may implement any of the configurations of secondary module 20 described hereinabove with reference to Figs. 1, 3, 4, 5, 6, 7, 8, 9, and/or 10 mutatis mutandis. By way of example and not limitation, secondary module is shown in Fig. 11 in the configuration of secondary
15 module 20 shown in Figs. 1 and 3. (For applications in which secondary module is configured as described hereinabove with reference to Fig. 5 and/or Fig. 6, greatest axial length L2 of secondary-module lateral fenestration 134 may be less than described hereinabove, e.g., may equal at least 20% of first perimeter P1 of distal main-module end 36 of main stent-graft 24 of main module 20, when the main module is unconstrained in
20 the radially-expanded state thereof. In the configuration described with reference to Figs. 11 and 12, secondary-module lateral fenestration 134 need only be sufficiently large to allow sufficient blood flow to brachiocephalic artery 70.)

Figs. 13A and 13B are schematic illustrations of respective configurations of tertiary module 328, in accordance with respective applications of the present invention.
25 Tertiary module 328 comprises a generally tubular tertiary stent-graft 380, which typically comprises a tertiary generally tubular support element 382 and a tertiary covering element 384 that is attached to and at least partially covers (e.g., only partially covers) the tertiary support element. Tertiary module 328 and stent-graft 380 have distal and proximal ends 381 and 383. Support element 382 typically comprises a plurality of tertiary structural
30 stent elements 386. For some applications, tertiary structural stent elements 386 are arranged as a plurality of circumferential stent springs 388. Tertiary covering element 384 serves as a blood flow guide through at least a portion of the tertiary stent-graft.

Tertiary covering element 384 typically comprises at least one biologically-compatible substantially blood-impervious flexible sheet, which is attached (such as by stitching) to at least a portion of the respective support element, on either side of the surfaces defined by the support element. The flexible sheet may comprise, for example, a polymeric material (e.g., a polyester, or polytetrafluoroethylene), a textile material (e.g., polyethylene terephthalate (PET)), natural tissue (e.g., saphenous vein or collagen), or a combination thereof.

In the configuration shown in Fig. 13A, tertiary module 328 is shaped so as to define a sealing interface 372, which is similar to sealing interface 172 described hereinabove with reference to Figs. 3, 4, 5, 6, and 7, and/or hereinbelow with reference to Figs. 1, 3, 4, 5, 6, 7, 8, and 11. Sealing interface 372 is sized and configured to form a blood-impervious seal with second (superior) lateral fenestration 368 of main module 320, as shown in Fig. 11. For some applications, sealing interface 372 and/or second (superior) lateral fenestration 368 implement sealing techniques described in US Patent Application Publication 2012/0179236 to Benary et al. and/or PCT Publication WO 2013/005207 to Shalev.

In the configuration shown in Fig. 13A, tertiary module 328 includes covered and uncovered axial portions, similar to the covered and uncovered axial portions 242 and 244 described hereinabove with reference to Fig. 9. Tertiary module 328 may implement any of the features described hereinabove with reference to Fig. 9, mutatis mutandis. Tertiary module 328 is sized and configured to form a blood-impervious seat with second (superior) lateral fenestration 368 of main module 320, using the techniques described hereinabove with reference to Fig. 10, mutatis mutandis.

Reference is again made to Fig. 11. In an exemplary transluminal delivery procedure for implanting multi-component stent-graft system 310, the stent-grafts of system 310 are endovascularly (typically percutaneously) introduced into the thoracic aorta, such as via one of the iliac arteries, while the stent-grafts are positioned in one or more outer tubes of a delivery tool in their radially-compressed states.

Typically, the exemplary procedure begins with the advancing of a guidewire up the descending aorta and into left common carotid artery 18. Main stent-graft 324 of main module 320 is initially positioned in its radially-compressed state within an outer tube of a delivery tool, typically near a leading end of the outer tube. The outer tube is advanced

over the guidewire, until main stent-graft 324 is partially disposed in left common carotid artery 18 and partially disposed in the upper part of the descending aorta. The guidewire is withdrawn, leaving the outer tube in place. The main stent-graft is held in place as the outer tube is withdrawn, thereby delivering the main stent-graft from the outer tube. Main stent-graft 324 typically self-expands, until it assumes its radially-expanded state, upon reaching typically about 80-90% of its maximum unconstrained size, and/or being constrained from further expansion by the wall of the blood vessels, as shown in Fig. 11. Alternatively, the main stent-graft (and/or the other stent-grafts, as described hereinbelow) is delivered using an over-the-wire (OTW) approach, in which the guidewire is left in place until the stent-graft is expanded, and thereafter the guidewire is withdrawn.

Descending-aorta axial portion 42 of main stent-graft 324, including distal main-module end 336, is positioned in the upper part of the descending aorta, and supra-arch axial portion 44 of main stent-graft 324, including proximal main-module end 338, is positioned in left common carotid artery 18. First (inferior) lateral fenestration 34 is disposed in aortic arch 19 facing upstream, generally toward ascending aorta 17, in a vicinity of the bifurcation of aortic arch 19 and left common carotid artery 18. Second (superior) lateral fenestration 368 is axially aligned with and faces left subclavian artery 16. For some applications, proper rotational alignment and/or axial orientation of the first and/or second lateral fenestrations is achieved using fluoroscopy. For example, main stent-graft 324 may comprise one or more radiopaque markers in a vicinity of (e.g., on a periphery of) the one or both of the lateral fenestrations.

A guidewire (either the same guidewire used to deploy the main stent-graft, or a second guidewire) is advanced up the descending aorta, through a proximal portion of main stent-graft 324, through second (superior) lateral fenestration 368, and into left subclavian artery 16. Tertiary stent-graft 380 of tertiary module 328 is positioned in its radially-compressed state within an outer tube of a delivery tool (either the same outer tube used to deploy the main stent-graft, or a second outer tube), typically near a leading end of the outer tube. The outer tube is advanced over the guidewire, until tertiary stent-graft 380 is partially disposed in left subclavian artery 16, and partially disposed within radially-expanded main stent-graft 324. The guidewire is withdrawn, leaving the outer tube in place.

The tertiary stent-graft is held in place as the outer tube is withdrawn, thereby

delivering the tertiary stent-graft from the outer tube. Tertiary stent-graft 380 typically self-expands, until it assumes its radially-expanded state, upon reaching its maximum unconstrained size, and/or being constrained from further expansion by the wall of the left subclavian artery. Tertiary stent-graft 380 is thus adapted for transluminal delivery in its
5 radially-compressed state through a portion of main stent-graft 324 and second (superior) lateral fenestration 368, while the main stent-graft is in its radially-expanded state.

A proximal portion of tertiary stent-graft 380, including distal end 383, is positioned within main stent-graft 324, and tertiary covering element 384 (e.g., at sealing interface 372 in the configuration shown in Figs. 11 and 13A) of tertiary stent-graft 380 is
10 sealingly coupled to second (superior) lateral fenestration 368 of main stent-graft 324.

A guidewire (either the same guidewire used to deploy the main stent-graft and/or tertiary stent-graft, or another guidewire) is advanced up the descending aorta, through a distal portion of main stent-graft 324, out of first (inferior) lateral fenestration 34, and into aortic arch 19, extending toward, or partially into, ascending aorta 17. Secondary stent-
15 graft 26 of secondary module 322 is positioned in its radially-compressed state within an outer tube of a delivery tool (either the same outer tube used to deploy the main stent-graft and/or the tertiary stent-graft, or another outer tube), typically near a leading end of the outer tube. The outer tube is advanced over the guidewire, until secondary stent-graft 26 is partially disposed in aortic arch 19, extending toward, or partially into, ascending aorta
20 17, and partially disposed within radially-expanded main stent-graft 324 in the upper part of the descending aorta. The guidewire is withdrawn, leaving the outer tube in place.

The secondary stent-graft is rotationally aligned such that the at least one lateral opening 174 faces left common carotid artery 18, so as to allow blood flow to the left common carotid artery (and, for applications in which the secondary stent-graft is long
25 enough, so as to allow blood flow into brachiocephalic artery 70). The secondary stent-graft may comprise one or more radiopaque markers to facilitate such proper rotational alignment. For example, the radiopaque markers may be positioned on one or more edges of the at least one lateral opening.

The secondary stent-graft is held in place as the outer tube is withdrawn, thereby
30 delivering the secondary stent-graft from the outer tube. Secondary stent-graft 26 typically self-expands, until it assumes its radially-expanded state, upon reaching its maximum unconstrained size, and/or being constrained from further expansion by the

wall of the blood vessels. Secondary stent-graft 26 is thus adapted for transluminal delivery in its radially-compressed state through a portion of main stent-graft 324 and first (inferior) lateral fenestration 34, while the main stent-graft is in its radially-expanded state.

5 A distal portion of secondary stent-graft 26, including distal secondary-module end 136, is positioned within main stent-graft 324, and sealing interface 172 of secondary stent-graft 26 is sealingly coupled to first (inferior) lateral fenestration 34 of main stent-graft 324. A proximal portion of secondary stent-graft 26, including proximal end 138, is positioned in aortic arch 19. As mentioned, the at least one lateral opening 174 faces left
10 common carotid artery 18. Secondary module 322 reduces blood turbulence in the aortic arch, and serves as a funnel that creates a gradual taper of the blood flow into first (inferior) lateral fenestration 34 of main stent-graft 324.

Alternatively, secondary module 322 is deployed before tertiary module 328 is deployed.

15 Reference is made to Figs. 1, 3, 4, 5, 6, 7, 8, and 11. For some applications, sealing interface 172 is shaped so as to define a neck portion longitudinally flanked by proximal and distal portions. The neck portion is generally radially narrower than the proximal and distal portions. For some applications, sealing interface 172 and/or lateral fenestration 34 implement sealing techniques described in US Patent Application
20 Publication 2012/0179236 to Benary et al. and/or PCT Publication WO 2013/005207 to Shalev, which are incorporated herein by reference. Alternatively, all of the configurations of secondary module 22 described with reference to Figs. 1, 3, 4, 5, 6, 7, 8, and 11 may implement the sealing techniques described hereinabove regarding secondary
25 module 222 with reference to Figs. 9 and 10 (i.e., rather than defining a narrower neck portion, secondary covering element 132 of secondary stent-graft 26 may instead only partially axially cover secondary support element 130 and define sealing interface 172B).

Reference is again made to Figs. 1 and 2A-B, as well as to Figs. 14A-B, which are schematic illustrations of kinking properties of different axial portions of main stent-graft 24, in accordance with an application of the present invention. For some applications:

- 30
- if distal axial portion 58 of main stent-graft 24, when the main stent-graft is in the radially-expanded state, is placed and constrained in a first curved tube 390 having a circular cross-section and an inner diameter equal to an outer

diameter of distal axial portion 58, distal axial portion 58 experiences kinking only when at least an axial portion 392 of the first curved tube has less than a first radius of curvature r_1 , as shown in Fig. 14A, and

- if dissection-reinforcement axial portion 48 of main stent-graft 24, when the main stent-graft is in the radially-expanded state, is placed and constrained in a second curved tube 394 having a circular cross-section and an inner diameter equal to an outer diameter of dissection-reinforcement axial portion 48, dissection-reinforcement axial portion 48 experiences kinking only when at least an axial portion 396 of the second curved tube has less than a second radius of curvature r_2 , which second radius of curvature is at least 30%, e.g., at least 50%, less than the first radius of curvature r_1 , as shown in Fig. 14B.

As used in the present application, including in the claims, "kinking," means that the graft material of main covering element 32 is pinched, or folded in a blood-flow-disturbing manner. It is noted that the outer diameters of the axial portions may vary axially therealong, in which case the inner diameters of the curved tubes would also correspondingly vary. It is also noted that the first and second curved tubes are not elements of multi-component stent-graft system 10, but are rather geometric constructs used to describe certain features of the main stent-graft.

Reference is now made to Fig. 15, which is a schematic illustration of kinking in a stent-graft 400. As described hereinabove with reference to Figs. 2A-B and 14A-B, for some applications dissection-reinforcement axial portion 48 is configured to avoid kinking. Without such configuration, for example if substantial axial spacing is provided between adjacent stent springs 402 of stent-graft 400, the stent-graft would be more prone to kinking 404, as shown in Fig. 14.

Although multi-component stent-graft systems 10 and 310 are generally described herein as being used for treating Type B aortic dissection, the scope of the present invention also includes using these systems for treating other conditions, such as aortic aneurysms.

The scope of the present invention includes embodiments described in the following applications, which are assigned to the assignee of the present application and are incorporated herein by reference. In an embodiment, techniques and apparatus described in one or more of the following applications are combined with techniques and

apparatus described herein:

- US Application 12/529,936, filed September 4, 2009, which issued as US Patent 8,317,856
- US Provisional Application 60/892,885, filed March 5, 2007
- 5 • US Provisional Application 60/991,726, filed December 2, 2007
- US Provisional Application 61/219,758, filed June 23, 2009
- US Provisional Application 61/221,074, filed June 28, 2009
- US Application 13/380,278, filed December 22, 2011, which published as US Patent Application Publication 2012/0150274
- 10 • US Application 13/384,075, filed January 13, 2012, which published as US Patent Application Publication 2012/0179236
- US Application 13/505,996, filed May 3, 2012, which published as US Patent Application Publication 2012/0310324
- US Application 13/512,778, filed September 24, 2012, which published as US Patent Application Publication 2013/0013050
- 15 • US Application 13/513,397, filed June 1, 2012, which published as US Patent Application Publication 2012/0330399
- US Application 13/514,240, filed June 6, 2012, which published as US Patent Application Publication 2013/0013051
- 20 • US Application 13/577,161, filed August 3, 2012, which published as US Patent Application Publication 2013/0035751
- US Application 13/031,871, filed February 22, 2011, which published as US Patent Application Publication 2011/0208289
- US Provisional Application 61/496,613, filed June 14, 2011
- 25 • US Provisional Application 61/505,132, filed July 7, 2011
- US Provisional Application 61/529,931, filed September 1, 2011
- PCT Application PCT/IL2012/000060, filed February 2, 2012, which published as PCT Publication WO 2012/104842

- PCT Application PCT/IL2012/000083, filed February 16, 2012, which published as PCT Publication WO 2012/111006
- PCT Application PCT/IL2012/000095, filed March 1, 2012, which published as PCT Publication WO 2012/117395
- 5 • PCT Application PCT/IL2012/000148, filed April 4, 2012, which published as PCT Publication WO 2013/030818
- PCT Application PCT/IL2012/000190, filed May 15, 2012, which published as PCT Publication WO 2013/171730
- 10 • US Patent Application 13/523,296, filed June 14, 2012, which published as US Patent Application Publication 2012/0323305
- PCT Application PCT/IL2012/000241, filed June 19, 2012, which published as PCT Publication WO 2012/176187
- PCT Application PCT/IL2012/000269, filed July 2, 2012, which published as PCT Publication WO 2013/005207
- 15 • PCT Application PCT/IL2012/050424, filed October 29, 2012, which published as PCT Publication WO 2013/065040
- PCT Application PCT/IL2012/050506, filed December 4, 2012, which published as PCT Publication WO 2013/084235
- 20 • US Provisional Application 61/749,965, filed January 8, 2013, entitled, "Minimization of stent-graft migration during implantation"

It will be appreciated by persons skilled in the art that the present invention is not limited to what has been particularly shown and described hereinabove. Rather, the scope of the present invention includes both combinations and subcombinations of the various features described hereinabove, as well as variations and modifications thereof that are not in the prior art, which would occur to persons skilled in the art upon reading the
25 foregoing description.

CLAIMS

1. Apparatus comprising a generally tubular stent-graft, which has distal and proximal stent-graft ends and comprises:
- 5 a generally tubular support element, which comprises a plurality of structural stent elements; and
- a covering element that is attached to and at least partially covers the support element,
- wherein when the stent-graft is unconstrained in a radially-expanded state:
- 10 the covering element and the support element are shaped so as to together define a lateral fenestration having distal and proximal fenestration ends,
- a first perimeter of the distal stent-graft end equals at least 200% of a second perimeter of the proximal stent-graft end, and
- 15 the stent-graft includes a dissection-reinforcement axial portion, which (a) includes a portion of the structural stent elements, (b) has (i) a distal dissection-reinforcement end and (ii) a proximal dissection-reinforcement end that is disposed along the stent-graft no more than 20 mm proximal to the proximal fenestration end, (c) extends along the stent-graft for a distance equal to between 5% and 32% of a greatest perimeter of the stent-graft distally to the distal fenestration end, and (d) has a radial strength that is at least 10% greater than an
- 20 average radial strength of the entire stent-graft.
2. The apparatus according to claim 1,
- wherein the portion of the structural stent elements included by the dissection-reinforcement axial portion is a first portion of the structural stent elements, and
- wherein when the stent-graft is unconstrained in the radially-expanded state:
- 25 the stent-graft includes a distal-end axial portion, which includes a second portion of the structural stent elements, and
- the distal-end axial portion axially extends along the stent-graft from the distal end of stent-graft for a distance equal to between 5% and 32% of a greatest perimeter of the stent-graft distally to the distal fenestration end, and
- 30 the distal-end axial portion has a radial strength that is at least a 10% greater than the average radial strength of the entire stent-graft.
3. The apparatus according to claim 1, wherein an axial length of the dissection-

reinforcement axial portion is between 1 and 3 cm when the stent-graft is unconstrained in the radially-expanded state.

4. The apparatus according to claim 1, wherein the proximal dissection-reinforcement end is disposed along the stent-graft no more proximal than the distal fenestration end when the stent-graft is unconstrained in the radially-expanded state.

5. The apparatus according to claim 1, wherein the proximal dissection-reinforcement end is disposed along the stent-graft between the distal fenestration end and the proximal fenestration end, inclusive, when the stent-graft is unconstrained in the radially-expanded state.

6. The apparatus according to claim 1, wherein a distance between the distal dissection-reinforcement end and the distal stent-graft end equals between 32% and 160% of a largest perimeter of the stent-graft when the stent-graft is unconstrained in the radially-expanded state.

7. The apparatus according to claim 1, wherein the dissection-reinforcement axial portion extends along the stent-graft for a distance equal to between 10% and 22% of a greatest perimeter of the stent-graft distally to the distal fenestration end when the stent-graft is unconstrained in the radially-expanded state.

8. The apparatus according to claim 1, wherein the first perimeter equals at least 250% of the second perimeter.

9. The apparatus according to any one of claims 1-8, wherein the dissection-reinforcement axial portion is configured to be generally straight when the stent-graft is unconstrained in the radially-expanded state.

10. The apparatus according to any one of claims 1-8, wherein the structural stent elements of the dissection-reinforcement axial portion are arranged as a plurality of circumferential stent springs, and wherein a height, measured axially along the stent-graft, of at least one of the stent springs varies by less than 10% around a circumference of the stent spring when the stent-graft is unconstrained in the radially-expanded state.

11. The apparatus according to any one of claims 1-8, wherein the structural stent elements of the dissection-reinforcement axial portion are arranged as a plurality of circumferential stent springs, and wherein, for each one of the stent springs, a height, measured axially along the stent-graft, of the stent spring varies by less than 10% around a

circumference of the stent spring when the stent-graft is unconstrained in the radially-expanded state.

12. The apparatus according to any one of claims 1-8, wherein the first perimeter is between 5 and 15 cm, and the second perimeter is between 2.5 and 5.7 cm.

5 13. The apparatus according to any one of claims 1-8, wherein the stent-graft is shaped so as to define exactly one lateral fenestration when the stent-graft is unconstrained in the radially-expanded state.

14. The apparatus according to any one of claims 1-8,
wherein the lateral fenestration is an inferior first lateral fenestration, which faces
10 in a first radial direction, and

wherein, when the main stent-graft is unconstrained in the radially-expanded state, the main covering element and the main support element are shaped so as to together define a superior second lateral fenestration, which faces in a second radial direction generally opposite the first radial direction.

15 15. Apparatus comprising a generally tubular stent-graft, which has distal and proximal stent-graft ends and comprises:

a generally tubular support element, which comprises a plurality of structural stent elements arranged as a plurality circumferential stent springs; and

a covering element that is attached to and at least partially cover the support
20 element,

wherein when the stent-graft is unconstrained in a radially-expanded state:

the covering element and the support element are shaped so as to together define a lateral fenestration having distal and proximal fenestration ends,

a first perimeter of the distal stent-graft end equals at least 200% of a
25 second perimeter of the proximal stent-graft end,

the stent-graft includes a dissection-reinforcement axial portion, which (a) includes a first plurality of the stent springs, (b) has (i) a distal dissection-reinforcement end and (ii) a proximal dissection-reinforcement end that is disposed along the stent-graft no more than 20 mm proximal to the proximal
30 fenestration end, (c) extends along the stent-graft for a distance equal to between 5% and 32% of a greatest perimeter of the stent-graft distally to the distal fenestration end, and (d) is configured to be generally straight,

the stent-graft includes a distal axial portion, which (a) includes a second plurality of the stent springs, (b) is disposed along the stent-graft distal and axially adjacent to the distal dissection-reinforcement end, (c) extends along the stent-graft for a distance equal to between 5% and 32% of the greatest perimeter of the stent-graft distally to the distal fenestration end,

the stent springs have respective average heights, measured axially along the stent-graft, and

an average of the average heights of the first plurality of the stent springs is less than 75% of the average height of a proximal-most one of the second plurality of the stent springs.

16. The apparatus according to claim 15, wherein each of the average heights of the first plurality of the stent springs is less than 75% of the average heights of the proximal-most one of the second plurality of stent springs when the stent-graft is unconstrained in the radially-expanded state.

17. The apparatus according to any one of claims 15 and 16, wherein the average of the average heights of the first plurality of the stent springs is less than 75% of the average height of a second one of the second plurality of stent springs, other than the proximal-most one of the second plurality of stent springs when the stent-graft is unconstrained in the radially-expanded state.

18. The apparatus according to any one of claims 15 and 16, wherein the average of the average heights of the first plurality of the stent springs is less than 75% of each of the average heights of the second plurality of stent springs when the stent-graft is unconstrained in the radially-expanded state.

19. The apparatus according to claim 15, wherein the distal axial portion is configured to be generally straight when the stent-graft is unconstrained in the radially-expanded state.

20. The apparatus according to claim 15, wherein an axial length of the dissection-reinforcement axial portion is between 1 and 3 cm when the stent-graft is unconstrained in the radially-expanded state.

21. The apparatus according to claim 15, wherein the proximal dissection-reinforcement end is disposed along the stent-graft no more proximal than the distal

fenestration end when the stent-graft is unconstrained in the radially-expanded state.

22. The apparatus according to claim 15, wherein the proximal dissection-reinforcement end is disposed along the stent-graft between the distal fenestration end and the proximal fenestration end, inclusive, when the stent-graft is unconstrained in the
5 radially-expanded state.

23. The apparatus according to claim 15, wherein an axial spacing between two of the first plurality of the stent springs equals less than 10% of an average of the average heights of the two stent springs.

24. The apparatus according to claim 15, wherein the first perimeter equals at least
10 300% of the second perimeter.

25. The apparatus according to claim 15, wherein the dissection-reinforcement axial portion extends along the stent-graft for a distance equal to between 10% and 32% of the greatest perimeter of the stent-graft distally to the distal fenestration end when the stent-graft is unconstrained in the radially-expanded state.

15 26. The apparatus according to claim 15, wherein the distal axial portion extends to and reaches the distal stent-graft end.

27. The apparatus according to any one of claims 15-16, wherein the average height of at least one of the first plurality of stent springs varies by less than 10% around a circumference of the stent spring when the stent-graft is unconstrained in the radially-
20 expanded state.

28. The apparatus according to any one of claims 15-26, wherein, for each one of the first plurality of stent springs, the average height thereof varies by less than 10% around a circumference of the stent spring when the stent-graft is unconstrained in the radially-expanded state.

25 29. The apparatus according to any one of claims 15-26,
wherein, if the distal axial portion, when the stent-graft is in the radially-expanded state, is placed and constrained in a first curved tube having a circular cross-section and an inner diameter equal to an outer diameter of the distal axial portion, the distal axial portion experiences kinking only when at least an axial portion of the first curved tube has
30 less than a first radius of curvature, and

wherein, if the dissection-reinforcement axial portion, when the stent-graft is in

the radially-expanded state, is placed and constrained in a second curved tube having a circular cross-section and an inner diameter equal to an outer diameter of the dissection-reinforcement axial portion, the dissection-reinforcement axial portion experiences kinking only when at least an axial portion of the second curved tube has less than a
5 second radius of curvature, which second radius of curvature is at least 30% less than the first radius of curvature.

30. The apparatus according to any one of claims 15-26,

wherein the lateral fenestration is an inferior first lateral fenestration, which faces in a first radial direction, and

10 wherein, when the main stent-graft is unconstrained in the radially-expanded state, the main covering element and the main support element are shaped so as to together define a superior second lateral fenestration, which faces in a second radial direction generally opposite the first radial direction.

31. Apparatus comprising a stent-graft system, which comprises:

15 a main module, which has distal and proximal main-module ends, and comprises a generally tubular main stent-graft, which comprises (a) a main generally tubular support element, which comprises main structural stent elements, and (b) a main covering element that is attached to and at least partially covers the support element, wherein the main covering element and the main support element are shaped so as to together define a
20 lateral fenestration when the main module is unconstrained in a radially-expanded state thereof; and

a secondary module, which comprises a non-bifurcated secondary stent-graft, which comprises (a) a secondary support element, which comprises secondary structural stent elements, and (b) a secondary covering element that is attached to and at least
25 partially covers the secondary support element,

wherein when the secondary module is unconstrained in a radially-expanded state thereof:

the secondary module is shaped so as to define (a) a proximal secondary-module end, (b) a sealing interface distal to the proximal secondary-module end,
30 and (c) a central longitudinal axis therebetween, wherein the sealing interface is sized and configured to form a blood-impervious seal with the lateral fenestration of the main module, and

the secondary covering element is shaped so as to define at least one lateral opening that begins at and extends from the proximal secondary-module end toward the sealing interface along the central longitudinal axis for a distance equal to at least 50% of a greatest width of the secondary module, measured perpendicular to the central longitudinal axis.

32. The apparatus according to claim 31, wherein a greatest width of the at least one lateral opening, measured circumferentially around the secondary module, equals at least 90 degrees circumferentially around the proximal secondary-module end, the 90 degrees being measured at the sealing interface.

33. The apparatus according to claim 31, wherein at least one of the secondary structural stent elements traverses the at least one lateral opening when the secondary module is unconstrained in the radially-expanded state thereof.

34. The apparatus according to claim 31, wherein the at least one lateral opening extends from the proximal secondary-module end toward the sealing interface along at least 70% of a greatest width of the secondary module, measured perpendicular to the central longitudinal axis when the secondary module is unconstrained in the radially-expanded state thereof.

35. The apparatus according to claim 31, wherein the cross-sectional area of the secondary module, measured perpendicular to the central longitudinal axis, gradually tapers from the proximal secondary-module end to the sealing interface when the secondary module is unconstrained in the radially-expanded state thereof.

36. The apparatus according to any one of claims 31-35, wherein when the secondary module is unconstrained in the radially-expanded state thereof:

the at least one lateral opening includes at least first and second lateral openings, the secondary covering element is shaped so as to define the first and the second lateral openings, each of extends from the proximal secondary-module end toward the sealing interface along the central longitudinal axis for the distance equal to at least 50% of the greatest width of the secondary module,

the first and the second lateral openings face in different first and second radial directions extending from the central longitudinal axis, and

the first and the second lateral openings at least partially axially overlap along the central longitudinal axis.

37. The apparatus according to claim 36, wherein the first and the second lateral openings axially coincide along the central longitudinal axis.
38. The apparatus according to claim 36, wherein the first and the second radial directions are opposite each other.
- 5 39. The apparatus according to claim 38, wherein the secondary covering element is shaped so as to define two portions, which (a) extend to and reach the proximal secondary-module end, and (b) are shaped so as to define respective concave inner surfaces that face each other and the central longitudinal axis, and (c) are not joined to each other at the proximal secondary-module end.
- 10 40. The apparatus according to any one of claims 31-35, wherein the at least one lateral opening comprises exactly one lateral opening.
41. The apparatus according to claim 40, wherein when the secondary module is unconstrained in the radially-expanded state thereof:
- 15 the lateral opening faces in a first radial direction extending from the central longitudinal axis, and
- a portion of the secondary covering element that faces in a second radial direction opposite the first radial direction extends to and reaches the proximal secondary-module end.
42. The apparatus according to any one of claims 31-41, wherein a first perimeter of 20 the distal main-module end equals at least 200% of a second perimeter of the proximal main-module end when the main module is unconstrained in the radially-expanded state thereof.
43. The apparatus according to claim 42, wherein the first perimeter equals at least 300% of the second perimeter.
- 25 44. The apparatus according to any one of claims 31-41,
- wherein the lateral fenestration is an inferior first lateral fenestration, which faces in a first radial direction,
- wherein, when the main stent-graft is unconstrained in the radially-expanded state, the main covering element and the main support element are shaped so as to together 30 define a superior second lateral fenestration, which faces in a second radial direction generally opposite the first radial direction,

wherein the stent-graft system further comprises a generally tubular tertiary stent-graft, and

wherein the main and the tertiary stent-grafts are configured such that the tertiary stent-graft forms a blood-impervious seal with the main stent-graft around the superior
5 second lateral fenestration when the tertiary stent-graft is disposed therethrough, and the main stent-graft is in the radially-expanded state thereof and the tertiary stent-graft is in a radially-expanded state thereof.

45. Apparatus comprising a stent-graft system, which comprises:

a main module, which has distal and proximal main-module ends, and comprises a
10 generally tubular main stent-graft, which comprises (a) a main generally tubular support element, which comprises main structural stent elements, and (b) a main covering element that is attached to and at least partially covers the support element, wherein the main covering element and the main support element are shaped so as to together define a main-module lateral fenestration when the main module is unconstrained in a radially-
15 expanded state thereof; and

a secondary module, which comprises a non-bifurcated secondary stent-graft, which comprises (a) a secondary support element, which comprises secondary structural stent elements, and (b) a secondary covering element that is attached to and at least partially covers the secondary support element,

20 wherein when the secondary module is unconstrained in a radially-expanded state thereof:

the secondary module is shaped so as to define (a) a proximal secondary-module end, (b) a sealing interface distal to the proximal secondary-module end, and (c) a central longitudinal axis therebetween, wherein the sealing interface is
25 sized and configured to form a blood-impervious seal with the main-module lateral fenestration of the main module,

the secondary covering element is shaped so as to define at least one secondary-module lateral fenestration disposed distal to the proximal secondary-module end and proximal to the sealing interface, and

30 a greatest axial length of the secondary-module lateral fenestration, measured parallel to the central longitudinal axis, equals at least 33% of a first perimeter of the distal main-module end when the main module is unconstrained in the radially-expanded state thereof.

46. The apparatus according to claim 45, wherein at least one of the secondary structural stent elements traverses the secondary-module lateral fenestration.

47. The apparatus according to claim 45, wherein the greatest axial length of the secondary-module lateral fenestration equals at least 50% of the first perimeter of the distal main-module end when the secondary module is unconstrained in the radially-expanded state thereof.

48. The apparatus according to claim 45, wherein the cross-sectional area of the secondary module gradually tapers from the proximal secondary-module end to the sealing interface when the secondary module is unconstrained in the radially-expanded state thereof.

49. The apparatus according to any one of claims 45-48, wherein the at least one secondary-module lateral fenestration comprises exactly one secondary-module lateral fenestration.

50. The apparatus according to claim 49, wherein when the secondary module is unconstrained in the radially-expanded state thereof:

the secondary-module lateral fenestration faces in a first radial direction extending from the central longitudinal axis, and

a portion of the secondary covering element that faces in a second radial direction opposite the first radial direction extends to and reaches the proximal secondary-module end.

51. The apparatus according to any one of claims 45-48, wherein the first perimeter of the distal main-module end equals at least 200% of a second perimeter of the proximal main-module end when the main module is unconstrained in the radially-expanded state thereof.

52. The apparatus according to claim 51, wherein the first perimeter equals at least 300% of the second perimeter.

53. The apparatus according to any one of claims 45-48, wherein the secondary module further comprises a flexible sheet, which (a) is blood-sealingly joined to a portion of the secondary border, which portion extends around at least 25% of a perimeter of the secondary border and includes a distal end of the secondary border when the secondary module is unconstrained in the radially-expanded state thereof, and (b) extends radially

inward from the secondary border when the secondary module is unconstrained in the radially-expanded state thereof.

54. The apparatus according to claim 53, wherein a portion of the secondary structural stent elements are attached to the flexible sheet.

- 5 55. The apparatus according to any one of claims 45-48,
wherein the main-module lateral fenestration is an inferior first lateral fenestration,
which faces in a first radial direction,
wherein, when the main stent-graft is unconstrained in the radially-expanded state,
the main covering element and the main support element are shaped so as to together
10 define a superior second lateral fenestration, which faces in a second radial direction
generally opposite the first radial direction,
wherein the stent-graft system further comprises a generally tubular tertiary stent-
graft, and
wherein the main and the tertiary stent-grafts are configured such that the tertiary
15 stent-graft forms a blood-impervious seal with the main stent-graft around the superior
second lateral fenestration when the tertiary stent-graft is disposed therethrough, and the
main stent-graft is in the radially-expanded state thereof and the tertiary stent-graft is in a
radially-expanded state thereof.

56. Apparatus comprising a stent-graft system, which comprises:
20 a main module, which has distal and proximal main-module ends, and comprises a
generally tubular main stent-graft, which comprises (a) a main generally tubular support
element, which comprises main structural stent elements, and (b) a main covering element
that is attached to and at least partially covers the support element, wherein the main
covering element and the main support element are shaped so as to together define a
25 main-module lateral fenestration when the main module is unconstrained in a radially-
expanded state thereof; and
a secondary module, which comprises a non-bifurcated secondary stent-graft,
which comprises (a) a secondary support element, which comprises secondary structural
stent elements, (b) a secondary covering element that is attached to and at least partially
30 covers the secondary support element, and (c) a flexible sheet,
wherein when the secondary module is unconstrained in a radially-expanded state
thereof:

the secondary module is shaped so as to define (a) a proximal secondary-module end, (b) a sealing interface distal to the proximal secondary-module end, and (c) a central longitudinal axis therebetween, wherein the sealing interface is sized and configured to form a blood-impervious seal with the main-module lateral fenestration of the main module,

the secondary covering element is shaped so as to define at least one secondary-module lateral fenestration disposed distal to the proximal secondary-module end and proximal to the sealing interface, and

the flexible sheet (a) is blood-sealingly joined to a portion of a secondary border of the secondary-module lateral fenestration, which portion extends around at least 25% of a perimeter of the secondary border and includes a distal end of the secondary border when the secondary module is unconstrained in the radially-expanded state thereof, and (b) extends radially inward from the secondary border when the secondary module is unconstrained in the radially-expanded state thereof.

57. The apparatus according to claim 56, wherein a portion of the secondary structural stent elements are attached to the flexible sheet.

58. The apparatus according to claim 56,

wherein the main-module lateral fenestration is an inferior first lateral fenestration, which faces in a first radial direction,

wherein, when the main stent-graft is unconstrained in the radially-expanded state, the main covering element and the main support element are shaped so as to together define a superior second lateral fenestration, which faces in a second radial direction generally opposite the first radial direction,

wherein the stent-graft system further comprises a generally tubular tertiary stent-graft, and

wherein the main and the tertiary stent-grafts are configured such that the tertiary stent-graft forms a blood-impervious seal with the main stent-graft around the superior second lateral fenestration when the tertiary stent-graft is disposed therethrough, and the main stent-graft is in the radially-expanded state thereof and the tertiary stent-graft is in a radially-expanded state thereof.

59. Apparatus comprising a stent-graft system, which comprises:

a main module, which has distal and proximal main-module ends, and comprises a generally tubular main stent-graft, which comprises (a) a main generally tubular support element, which comprises main structural stent elements, and (b) a main covering element that is attached to and at least partially covers the support element, wherein the main covering element and the main support element are shaped so as to together define a lateral fenestration when the main module is unconstrained in a radially-expanded state thereof; and

a secondary module, which comprises a non-bifurcated secondary stent-graft, which comprises (a) a secondary support element, which comprises secondary structural stent elements, and (b) a secondary covering element that is attached to and partially covers the secondary support element,

wherein when the secondary module is unconstrained in a radially-expanded state thereof:

the secondary module is shaped so as to define (a) a proximal secondary-module end, (b) a sealing interface distal to the proximal secondary-module end, and (c) an anchoring axial portion therebetween having a central longitudinal axis and an anchoring-portion length, measured along the central longitudinal axis from the distal sealing interface to the proximal secondary-module end,

the sealing interface is sized and configured to form a blood-impervious seal with the lateral fenestration of the main module,

the secondary covering element at least covers the secondary support element along a covered axial portion of the anchoring axial portion, which covered axial portion extends proximally from the distal sealing interface for an axial covering distance equal to between 10% and 50% of the anchoring-portion length, the axial covering distance measured along the central longitudinal axis, wherein the secondary support element is uncovered proximally to the secondary covering element, and

the anchoring axial portion has a greatest anchoring-portion width that is (a) greater than a greatest proximal-end width at the proximal secondary-module end and (b) at least 20% greater than a greatest sealing-interface width at a narrowest portion of the distal sealing interface, the greatest anchoring-portion, sealing-interface, and proximal-end widths measured perpendicular to the central longitudinal axis.

60. The apparatus according to claim 59, wherein the anchoring axial portion has the greatest anchoring-portion width at an axial location at an axial distance from the proximal secondary-module end equal to between 33% and 60% of the anchoring-portion length, the axial distance measured along the central longitudinal axis, when the secondary module is unconstrained in the radially-expanded state thereof.
61. The apparatus according to claim 59, wherein the greatest anchoring-portion width is at least 50% greater than the greatest sealing-interface width at the narrowest portion of the distal sealing interface, when the secondary module is unconstrained in the radially-expanded state thereof.
62. The apparatus according to claim 59, wherein the axial covering distance from the distal sealing interface is equal to between 20% and 100% of an axial distance between the distal sealing interface and an axial location of the greatest anchoring-portion width, the axial distance measured along the central longitudinal axis, when the secondary module is unconstrained in the radially-expanded state thereof.
63. The apparatus according to claim 62, wherein the axial covering distance from the distal sealing interface is equal to between 30% and 60% of the axial distance between the distal sealing interface and the axial location of the greatest anchoring-portion width, when the secondary module is unconstrained in the radially-expanded state thereof.
64. The apparatus according to claim 59, wherein the axial covering distance equals between 10% and 35% of the anchoring-portion length, when the secondary module is unconstrained in the radially-expanded state thereof.
65. The apparatus according to claim 59, wherein the axial covering distance is at least 15% of the anchoring-portion length, when the secondary module is unconstrained in the radially-expanded state thereof.
66. The apparatus according to any one of claims 59-65, wherein the anchoring axial portion includes a plurality of the secondary structural stent elements, each of which has two longitudinal portions that extend toward the distal sealing interface, and an intermediary longitudinal portion that curves around the proximal secondary-module end, when the secondary module is unconstrained in the radially-expanded state thereof.
67. The apparatus according to any one of claims 59-65, wherein the anchoring axial portion includes a plurality of the secondary structural stent elements, some of which

touch one another, and none of which are fixed to one another, when the secondary module is unconstrained in the radially-expanded state thereof.

68. The apparatus according to any one of claims 59-65, wherein an uncovered axial portion of the anchoring portion extends from the proximal secondary-module end to a proximal end of the covered axial portion, for an axial uncovered distance equal to between 30 and 120 mm, when the secondary module is unconstrained in the radially-expanded state thereof.

69. The apparatus according to any one of claims 59-65, wherein the greatest proximal-end width equals zero.

70. A method for treating a patient comprising:

endovascularly introducing a generally tubular stent-graft, while in a radially-compressed state, and positioning the stent-graft such that (a) a proximal stent-graft end of the stent-graft is positioned in a branch of an aortic arch selected from the group consisting of: a left subclavian artery left subclavian artery, and a left common carotid artery, and (b) a distal stent-graft end of the stent-graft is positioned in a descending aorta, wherein the stent-graft includes (a) a generally tubular support element, which includes a plurality of structural stent elements, and (b) a covering element that is attached to and at least partially covers the support element; and

thereafter, transitioning the stent-graft to a radially-expanded state, in which (a) the covering element and the support element are shaped so as to together define a lateral fenestration that is disposed in the aortic arch, with the lateral fenestration facing upstream generally toward an ascending aorta, the lateral fenestration having distal and proximal fenestration ends, (b) a first perimeter of a distal stent-graft end of the stent-graft equals at least 200% of a second perimeter of the proximal stent-graft end, and (c) the stent-graft includes a dissection-reinforcement axial portion, which (i) includes a portion of the structural stent elements, (ii) has (x) a distal dissection-reinforcement end and (y) a proximal dissection-reinforcement end that is disposed along the stent-graft no more than 20 mm proximal to the proximal fenestration end, (iii) extends along the stent-graft for an axial distance equal to between 5% and 32% of a greatest perimeter of the stent-graft distally to the distal fenestration end, and (iv) has a radial strength that is at least 10% greater than an average radial strength of the entire stent-graft.

71. The method according to claim 70,

wherein the lateral fenestration is an inferior first lateral fenestration, which faces in a first radial direction,

wherein, when the main stent-graft is in the radially-expanded state, the main covering element and the main support element are shaped so as to together define a superior second lateral fenestration, which faces in a second radial direction generally opposite the first radial direction, and

wherein positioning the stent-graft comprises positioning the stent-graft such that (a) the proximal stent-graft end is positioned in the left common carotid artery, (b) the inferior first lateral fenestration is disposed in the aortic arch, with the inferior first lateral fenestration facing upstream generally toward the ascending aorta, and (c) the superior second lateral fenestration is axially aligned with and faces the left subclavian artery.

72. A method for treating a patient comprising:

endovascularly introducing a generally tubular stent-graft, while in a radially-compressed state, and positioning the stent-graft such that (a) a proximal stent-graft end of the stent-graft is positioned in a branch of an aortic arch selected from the group consisting of: a left subclavian artery left subclavian artery, and a left common carotid artery, and (b) a distal stent-graft end of the stent-graft is positioned in a descending aorta, wherein the stent-graft includes (a) a generally tubular support element, which includes a plurality of structural stent elements arranged as a plurality circumferential stent springs, and (b) a covering element that is attached to and at least partially covers the support element; and

thereafter, transitioning the stent-graft to a radially-expanded state, in which (a) the covering element and the support element are shaped so as to together define a lateral fenestration that is disposed in the aortic arch, with the lateral fenestration facing upstream generally toward an ascending aorta, the lateral fenestration having distal and proximal fenestration ends, (b) a first perimeter of a distal stent-graft end of the stent-graft equals at least 200% of a second perimeter of the proximal stent-graft end, (c) the stent-graft includes a dissection-reinforcement axial portion, which (i) includes a first plurality of the stent springs, (ii) has (x) a distal dissection-reinforcement end and (y) a proximal dissection-reinforcement end that is disposed along the stent-graft no more than 20 mm proximal to the proximal fenestration end, (iii) extends along the stent-graft for a distance equal to between 5% and 32% of a greatest perimeter of the stent-graft distally to the distal fenestration end, and (iv) is configured to be generally straight when the stent-graft

is unconstrained in the radially-constrained state, (d) the stent-graft includes a distal axial portion, which (i) includes a second plurality of the stent springs, (ii) is disposed along the stent-graft distal and axially adjacent to the distal dissection-reinforcement end, (iii) extends along the stent-graft for a distance equal to between 5% and 32% of the greatest
5 perimeter of the stent-graft distally to the distal fenestration end, (e) the stent springs have respective average heights, measured axially along the stent-graft, and (f) an average of the average heights of the first plurality of the stent springs is less than 75% of the average height of a proximal-most one of the second plurality of the stent springs.

73. The method according to claim 72,
10 wherein the lateral fenestration is an inferior first lateral fenestration, which faces in a first radial direction,

wherein, when the main stent-graft is in the radially-expanded state, the main covering element and the main support element are shaped so as to together define a superior second lateral fenestration, which faces in a second radial direction generally
15 opposite the first radial direction, and

wherein positioning the stent-graft comprises positioning the stent-graft such that (a) the proximal stent-graft end is positioned in the left common carotid artery, (b) the inferior first lateral fenestration is disposed in the aortic arch, with the inferior first lateral fenestration facing upstream generally toward the ascending aorta, and (c) the superior
20 second lateral fenestration is axially aligned with and faces the left subclavian artery.

74. A method for treating a patient comprising:
endovascularly introducing a main module, while in a radially-compressed state thereof, and positioning the main module such that (a) a proximal main-module end of the main module is positioned in a branch of an aortic arch selected from the group consisting
25 of: a left subclavian artery left subclavian artery, and a left common carotid artery, and (b) a distal main-module end of the main module is positioned in a descending aorta, wherein the main module includes a generally tubular main stent-graft, which includes (a) a main generally tubular support element, which includes main structural stent elements, and (b) a main covering element that is attached to and at least partially covers the support
30 element;

thereafter, transitioning the main stent-graft to a radially-expanded state thereof, in which the main covering element and the main support element are shaped so as to

together define a lateral fenestration that is disposed in the aortic arch, with the lateral fenestration facing upstream generally toward an ascending aorta;

5 endovascularly introducing and passing a secondary module, while in a radially-compressed state thereof, through a distal portion of the main stent-graft such that the secondary module is disposed through the lateral fenestration and is disposed partially in the aortic arch, wherein the secondary module includes a non-bifurcated secondary stent-graft, which includes (a) a secondary support element, which includes secondary structural stent elements, and (b) a secondary covering element that is attached to and at least partially covers the secondary support element; and

10 thereafter, transitioning the secondary module to a radially-expanded state thereof, in which the secondary module is shaped so as to define (a) a proximal secondary-module end, (b) a sealing interface distal to the proximal secondary-module end, and (c) a central longitudinal axis therebetween, such that the sealing interface forms a blood-impervious seal with the lateral fenestration of the main module, and the secondary covering element
15 is shaped so as to define at least one lateral opening that begins at and extends from the proximal secondary-module end toward the sealing interface along the central longitudinal axis for a distance equal to at least 50% of a greatest width of the secondary module, measured perpendicular to the central longitudinal axis.

75. The method according to claim 74,

20 wherein the lateral fenestration is an inferior first lateral fenestration, which faces in a first radial direction,

wherein, when the main stent-graft is in the radially-expanded state, the main covering element and the main support element are shaped so as to together define a superior second lateral fenestration, which faces in a second radial direction generally
25 opposite the first radial direction, and

wherein positioning the stent-graft comprises positioning the stent-graft such that (a) the proximal stent-graft end is positioned in the left common carotid artery, (b) the inferior first lateral fenestration is disposed in the aortic arch, with the inferior first lateral fenestration facing upstream generally toward the ascending aorta, and (c) the superior
30 second lateral fenestration is axially aligned with and faces the left subclavian artery.

76. A method for treating a patient comprising:

endovascularly introducing a main module, while in a radially-compressed state

thereof, and positioning the main module such that (a) a proximal main-module end of the main module is positioned in a branch of an aortic arch selected from the group consisting of: a left subclavian artery left subclavian artery, and a left common carotid artery, and (b) a distal main-module end of the main module is positioned in a descending aorta, wherein
5 the main module includes a generally tubular main stent-graft, which includes (a) a main generally tubular support element, which includes main structural stent elements, and (b) a main covering element that is attached to and at least partially covers the support element;

thereafter, transitioning the main stent-graft to a radially-expanded state thereof, in
10 which the main covering element and the main support element are shaped so as to together define a main-module lateral fenestration that is disposed in the aortic arch, with the main-module lateral fenestration facing upstream generally toward an ascending aorta;

endovascularly introducing and passing a secondary module, while in a radially-compressed state thereof, through a distal portion of the main stent-graft such that the
15 secondary module is disposed through the main-module lateral fenestration and is disposed partially in the aortic arch, wherein the secondary module includes a non-bifurcated secondary stent-graft, which includes (a) a secondary support element, which includes secondary structural stent elements, and (b) a secondary covering element that is attached to and at least partially covers the secondary support element; and

thereafter, transitioning the secondary module to a radially-expanded state thereof,
20 in which the secondary module is shaped so as to define (a) a proximal secondary-module end, (b) a sealing interface distal to the proximal secondary-module end, and (c) a central longitudinal axis therebetween, such that the sealing interface forms a blood-impervious seal with the main-module lateral fenestration of the main module, and the secondary
25 covering element is shaped so as to define at least one secondary-module lateral fenestration disposed distal to the proximal secondary-module end and proximal to the sealing interface, wherein a greatest axial length of the secondary-module lateral fenestration, measured parallel to the central longitudinal axis, equals at least 33% of a first perimeter of the distal main-module end.

30 77. A method for treating a patient comprising:

endovascularly introducing a main module, while in a radially-compressed state thereof, and positioning the main module such that (a) a proximal main-module end of the main module is positioned in a branch of an aortic arch selected from the group consisting

of: a left subclavian artery left subclavian artery, and a left common carotid artery, and (b) a distal main-module end of the main module is positioned in a descending aorta, wherein the main module includes a generally tubular main stent-graft, which includes (a) a main generally tubular support element, which includes main structural stent elements, and (b) 5 a main covering element that is attached to and at least partially covers the support element;

thereafter, transitioning the main stent-graft to a radially-expanded state thereof, in which the main covering element and the main support element are shaped so as to together define a main-module lateral fenestration that is disposed in the aortic arch, with 10 the main-module lateral fenestration facing upstream generally toward an ascending aorta;

endovascularly introducing and passing a secondary module, while in a radially-compressed state thereof, through a distal portion of the main stent-graft such that the secondary module is disposed through the main-module lateral fenestration and is disposed partially in the aortic arch, wherein the secondary module includes a non- 15 bifurcated secondary stent-graft, which includes (a) a secondary support element, which includes secondary structural stent elements, (b) a secondary covering element that is attached to and at least partially covers the secondary support element, and (c) a flexible sheet; and

thereafter, transitioning the secondary module to a radially-expanded state thereof, 20 in which (a) the secondary module is shaped so as to define (a) a proximal secondary-module end, (b) a sealing interface distal to the proximal secondary-module end, and (c) a central longitudinal axis therebetween, such that the sealing interface forms a blood-impervious seal with the main-module lateral fenestration of the main module, (b) the secondary covering element is shaped so as to define at least one secondary-module 25 lateral fenestration disposed distal to the proximal secondary-module end and proximal to the sealing interface, and (c) the flexible sheet (i) is blood-sealingly joined to a portion of a secondary border of the secondary-module lateral fenestration, which portion extends around at least 25% of a perimeter of the secondary border and includes a distal end of the secondary border, and (ii) extends radially inward from the secondary border when the 30 secondary module is unconstrained in the radially-expanded state thereof.

78. A method for treating a patient comprising:

endovascularly introducing a main module, while in a radially-compressed state thereof, and positioning the main module such that (a) a proximal main-module end of the

main module is positioned in a branch of an aortic arch selected from the group consisting of: a left subclavian artery left subclavian artery, and a left common carotid artery, and (b) a distal main-module end of the main module is positioned in a descending aorta, wherein the main module includes a generally tubular main stent-graft, which includes (a) a main
5 generally tubular support element, which includes main structural stent elements, and (b) a main covering element that is attached to and at least partially covers the support element;

thereafter, transitioning the main stent-graft to a radially-expanded state thereof, in which the main covering element and the main support element are shaped so as to
10 together define a lateral fenestration that is disposed in the aortic arch, with the lateral fenestration facing upstream generally toward an ascending aorta;

endovascularly introducing and passing a secondary module, while in a radially-compressed state thereof, through a distal portion of the main stent-graft such that the secondary module is disposed through the lateral fenestration and is disposed partially in
15 the aortic arch, wherein the secondary module includes a non-bifurcated secondary stent-graft, which includes (a) a secondary support element, which includes secondary structural stent elements, and (b) a secondary covering element that is attached to and partially covers the secondary support element; and

thereafter, transitioning the secondary module to a radially-expanded state thereof,
20 in which the secondary module is shaped so as to define (a) a proximal secondary-module end, (b) a sealing interface distal to the proximal secondary-module end, and (c) an anchoring axial portion therebetween having a central longitudinal axis and an anchoring-portion length, measured along the central longitudinal axis from the distal sealing interface to the proximal secondary-module end, such that the sealing interface forms a
25 blood-impervious seal with the lateral fenestration of the main module, the secondary covering element at least covers the secondary support element along a covered axial portion of the anchoring axial portion, which covered axial portion extends proximally from the distal sealing interface for an axial covering distance equal to between 10% and 50% of the anchoring-portion length, the axial covering distance measured along the
30 central longitudinal axis, wherein the secondary support element is uncovered proximally to the secondary covering element, and the anchoring axial portion has a greatest anchoring-portion width that is (a) greater than a greatest proximal-end width at the proximal secondary-module end and (b) at least 20% greater than a greatest sealing-

interface width at a narrowest portion of the distal sealing interface, the greatest anchoring-portion, sealing-interface, and proximal-end widths measured perpendicular to the central longitudinal axis.

FIG. 1

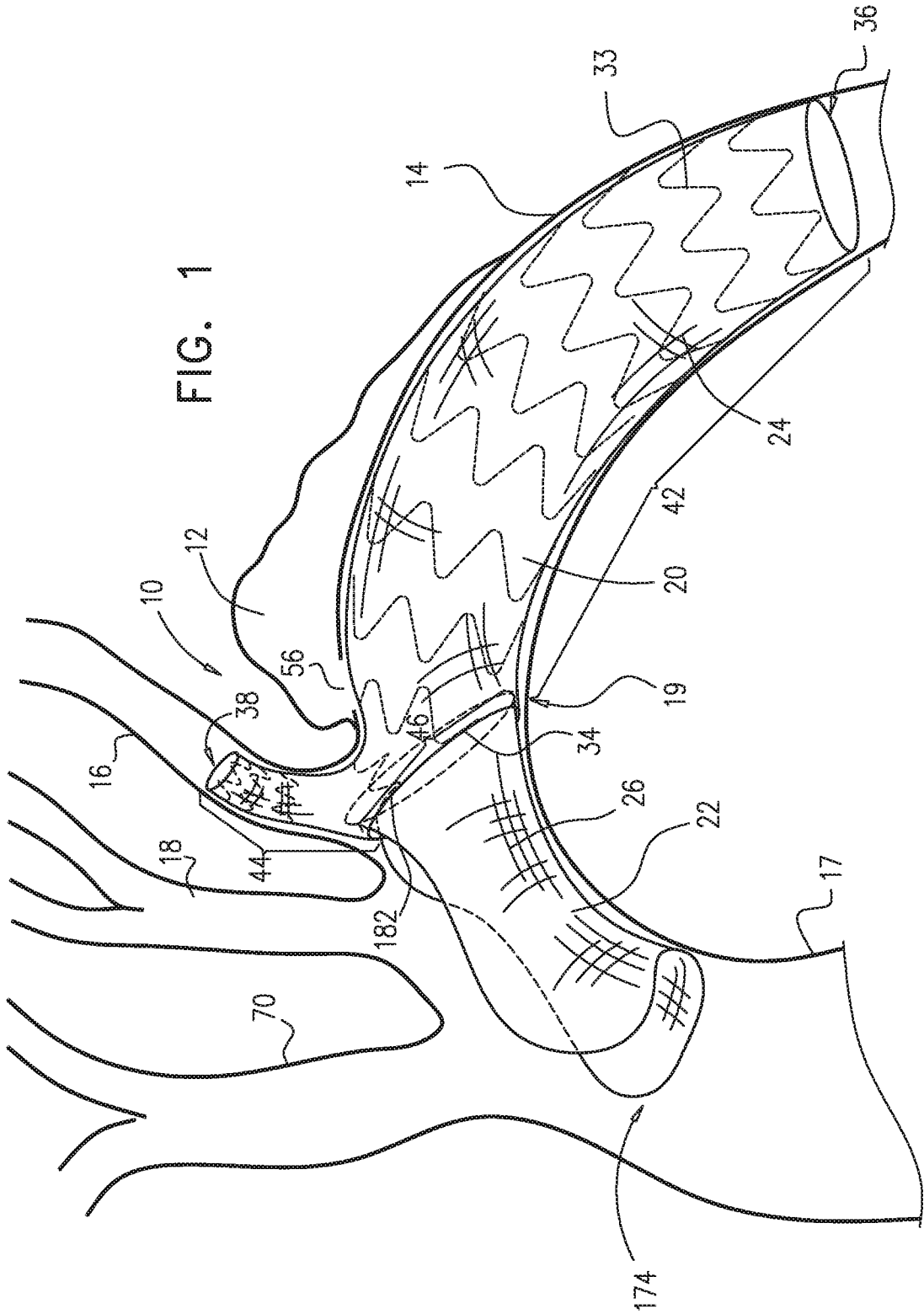

FIG. 2A

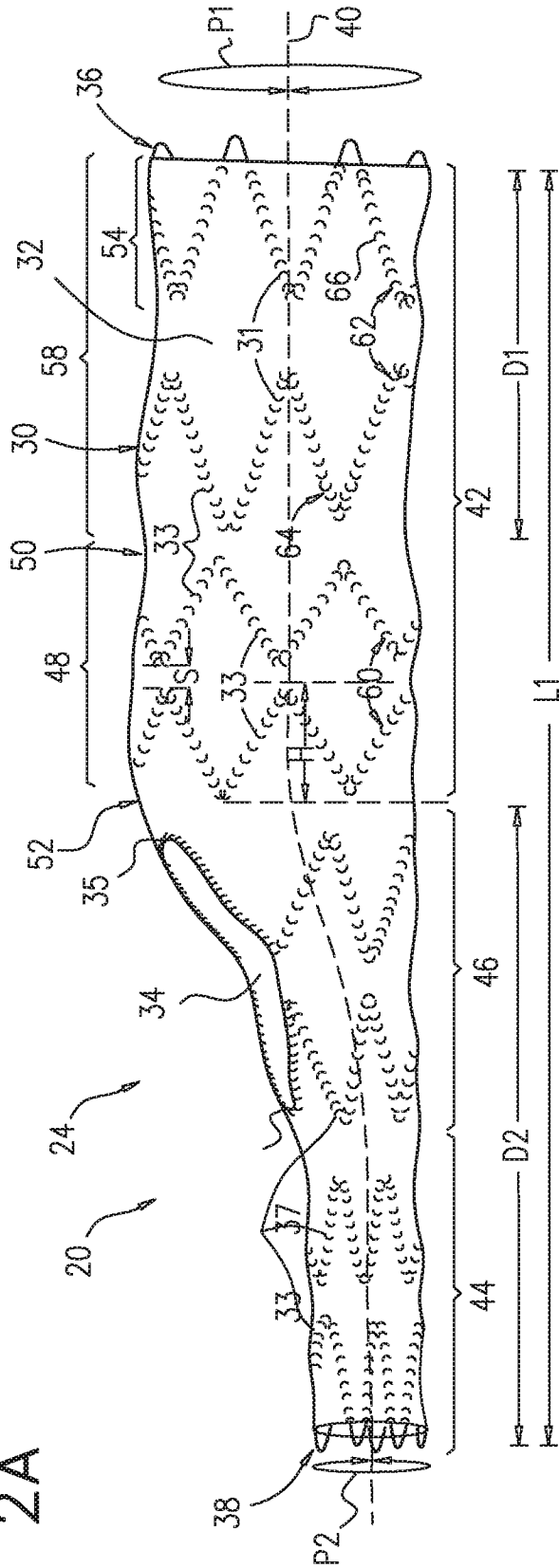

FIG. 2B

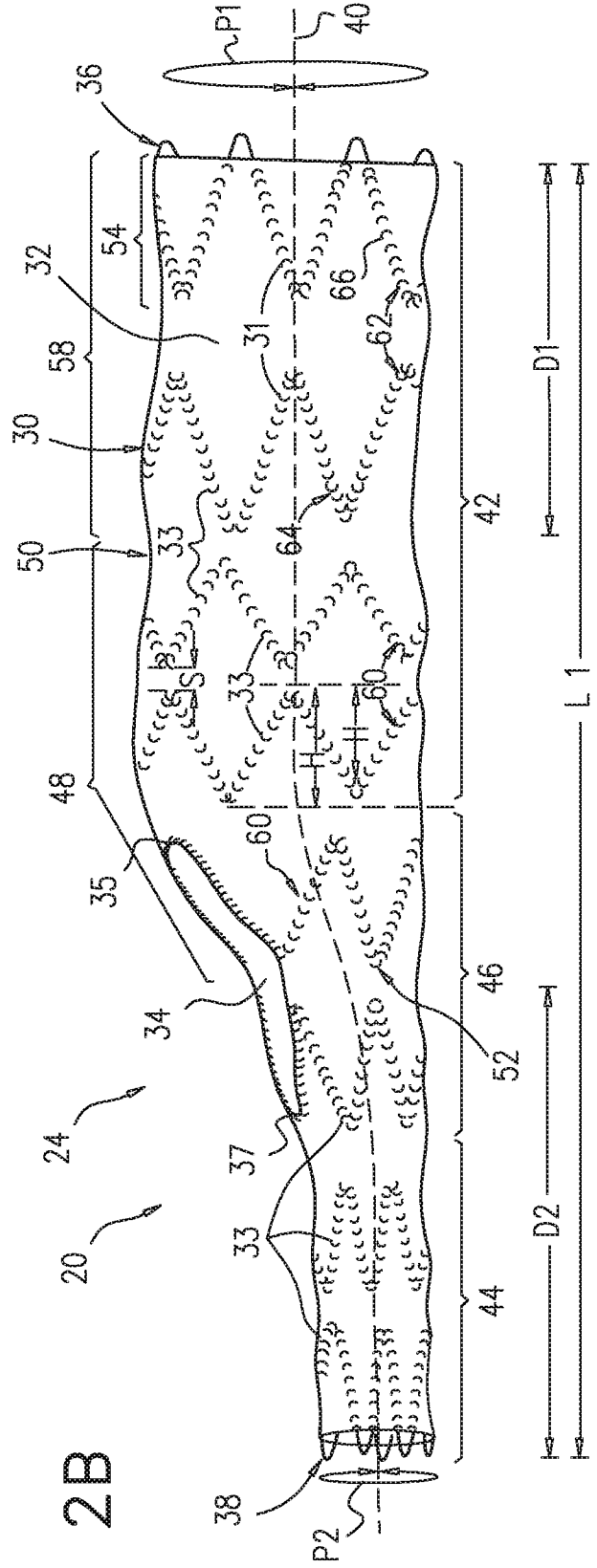

FIG. 4

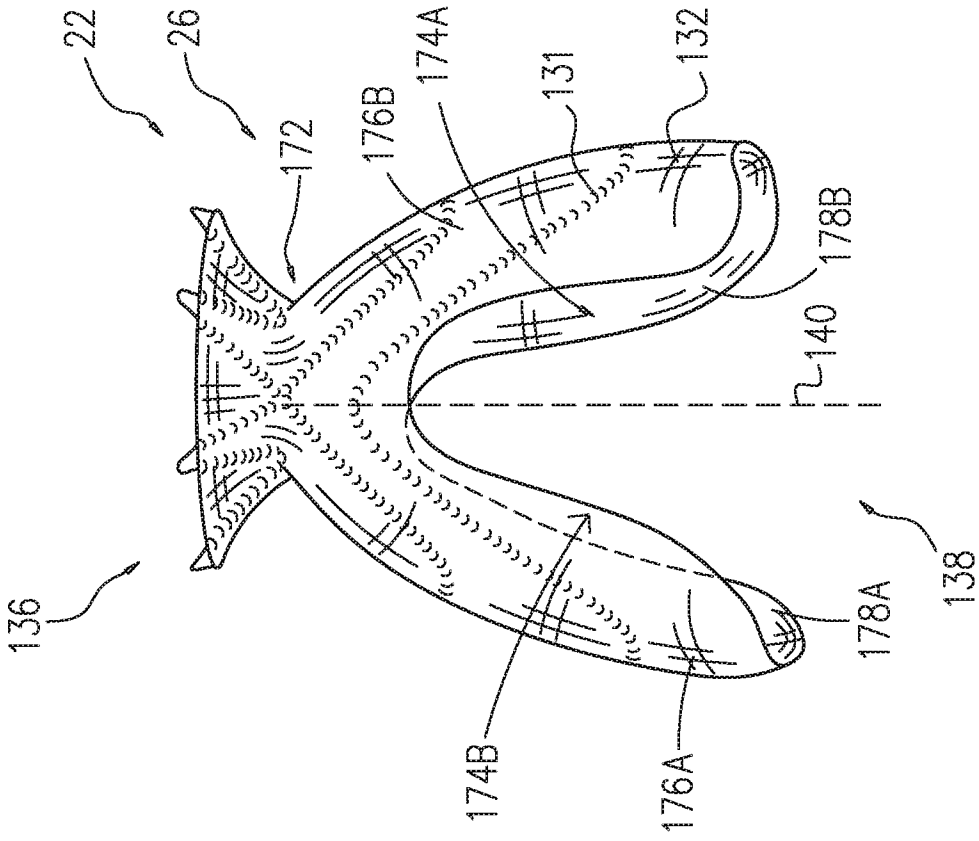

FIG. 3

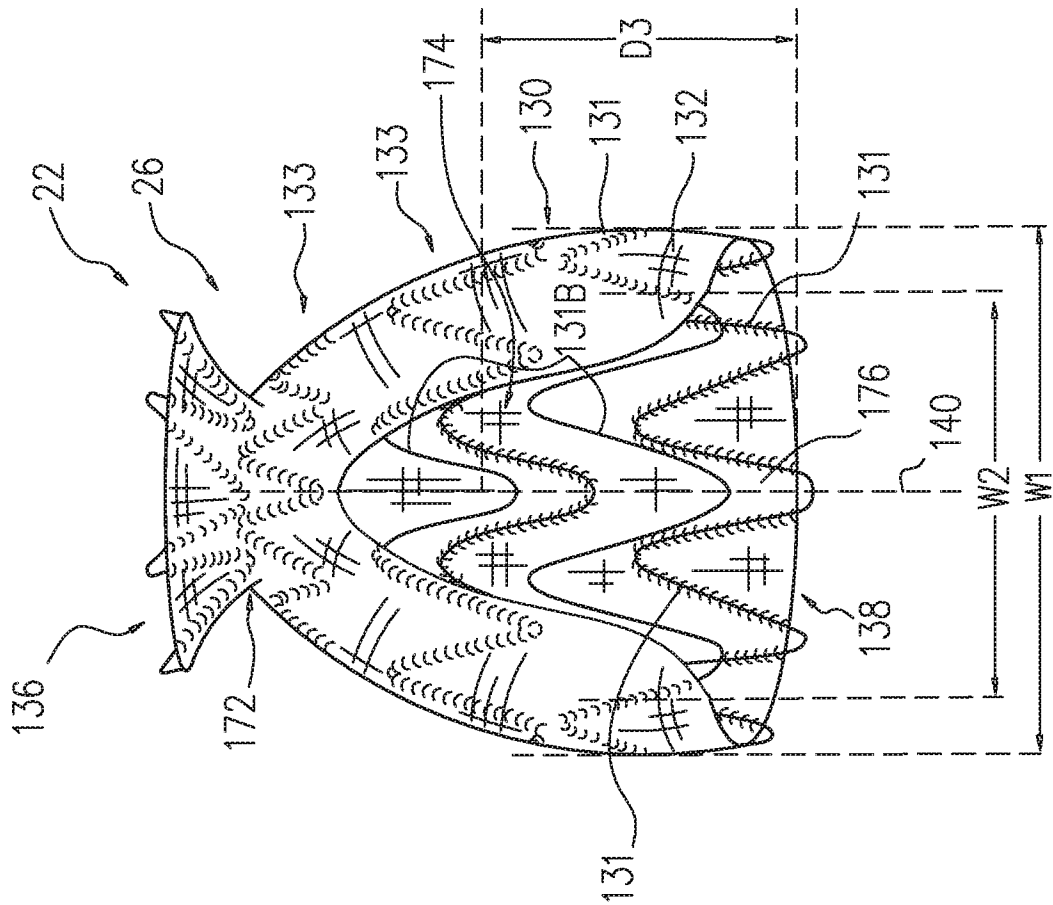

FIG. 7

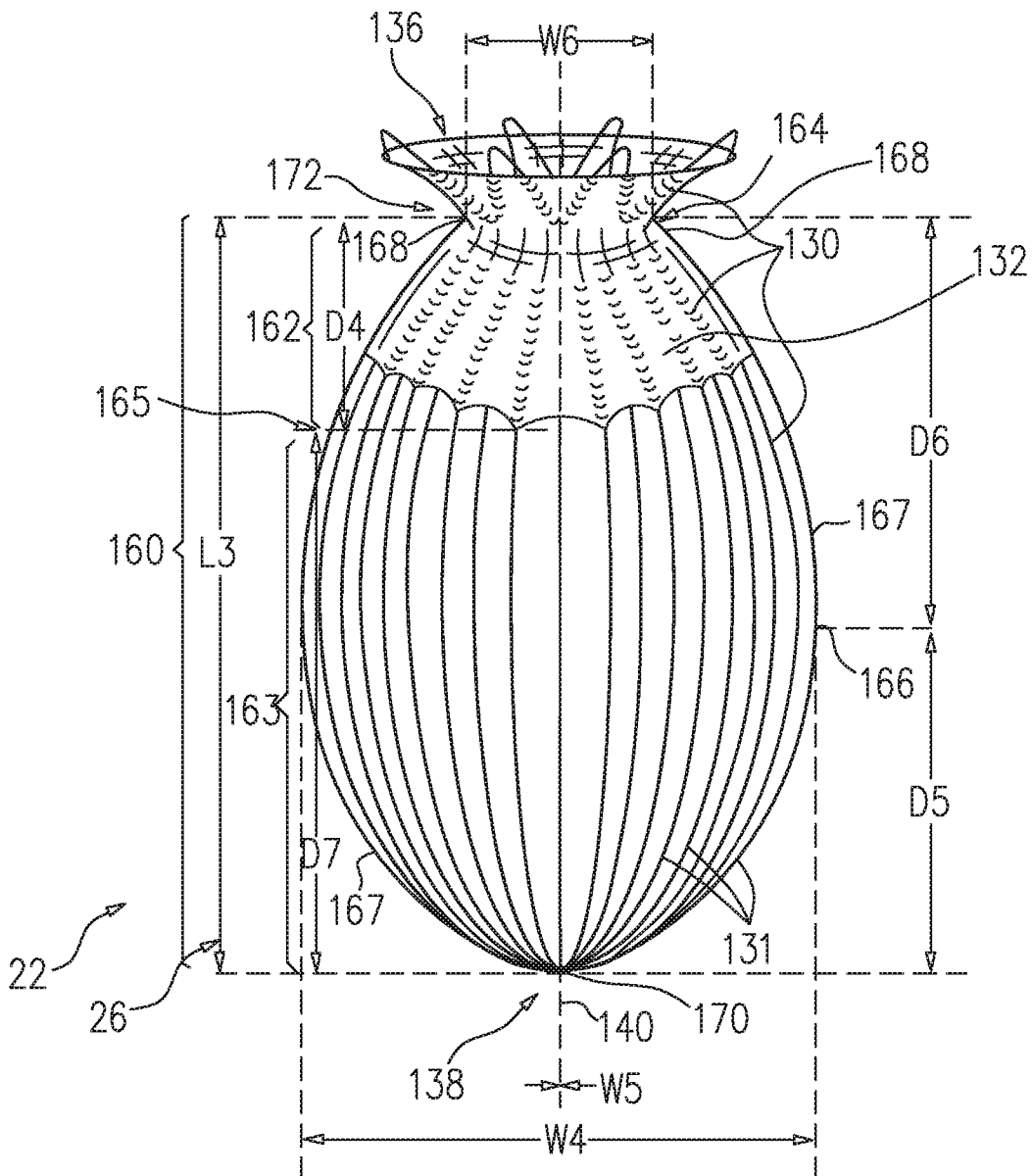

FIG. 8

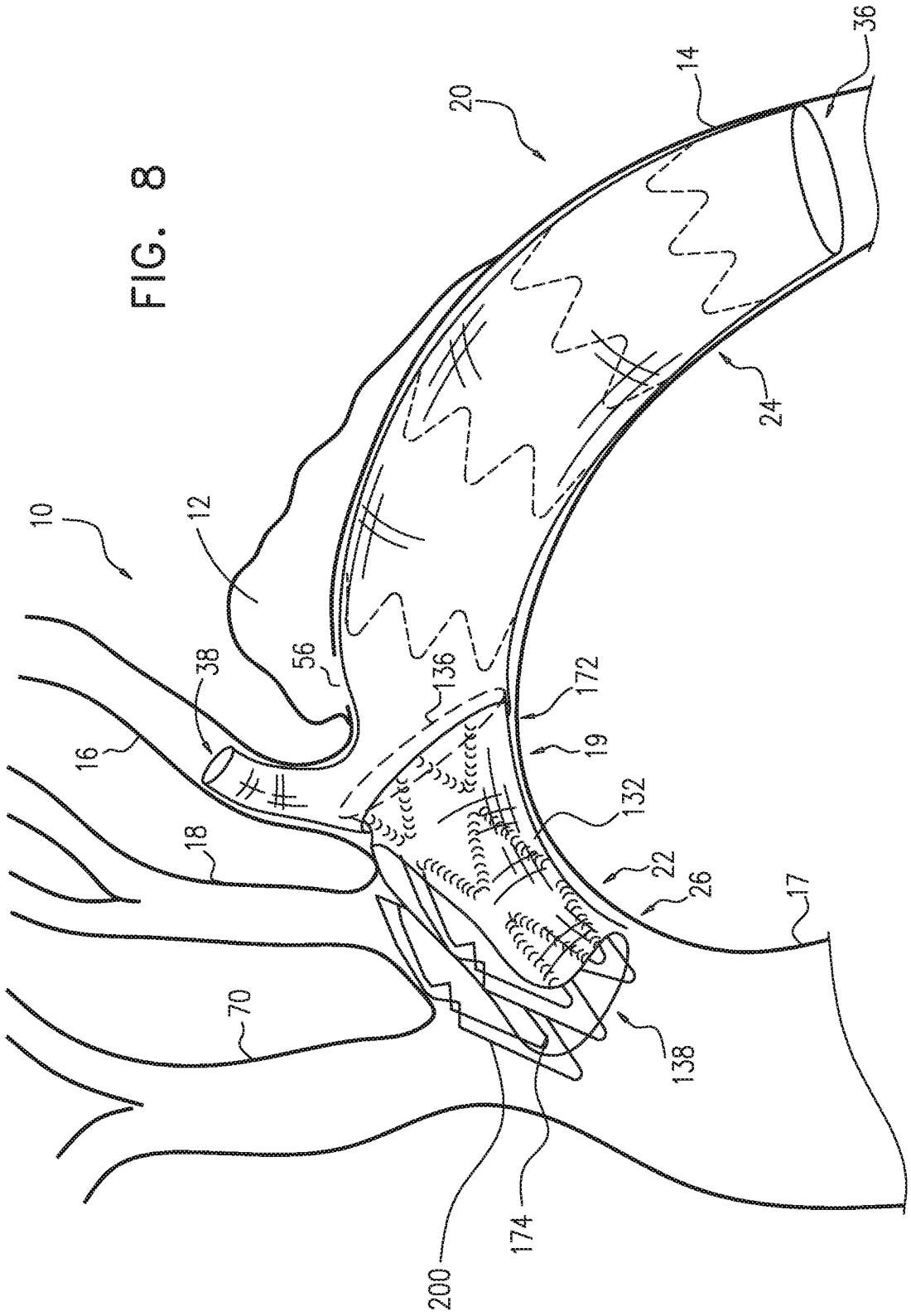

FIG. 9

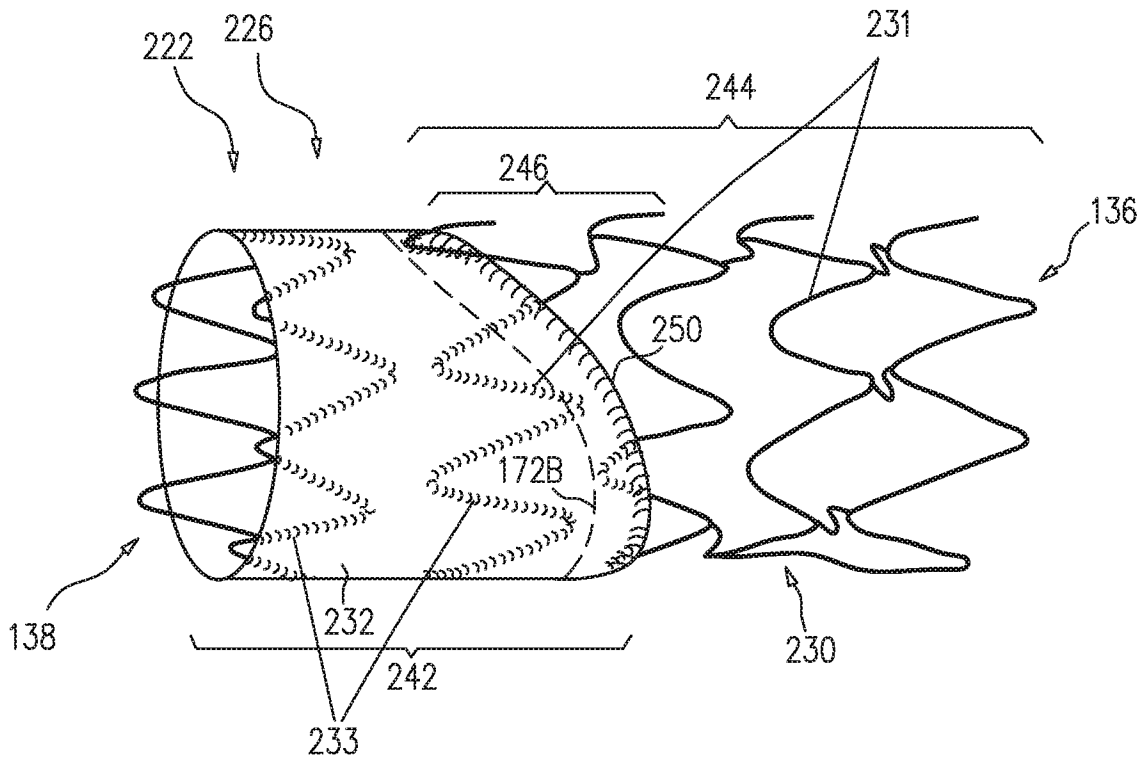

FIG. 10

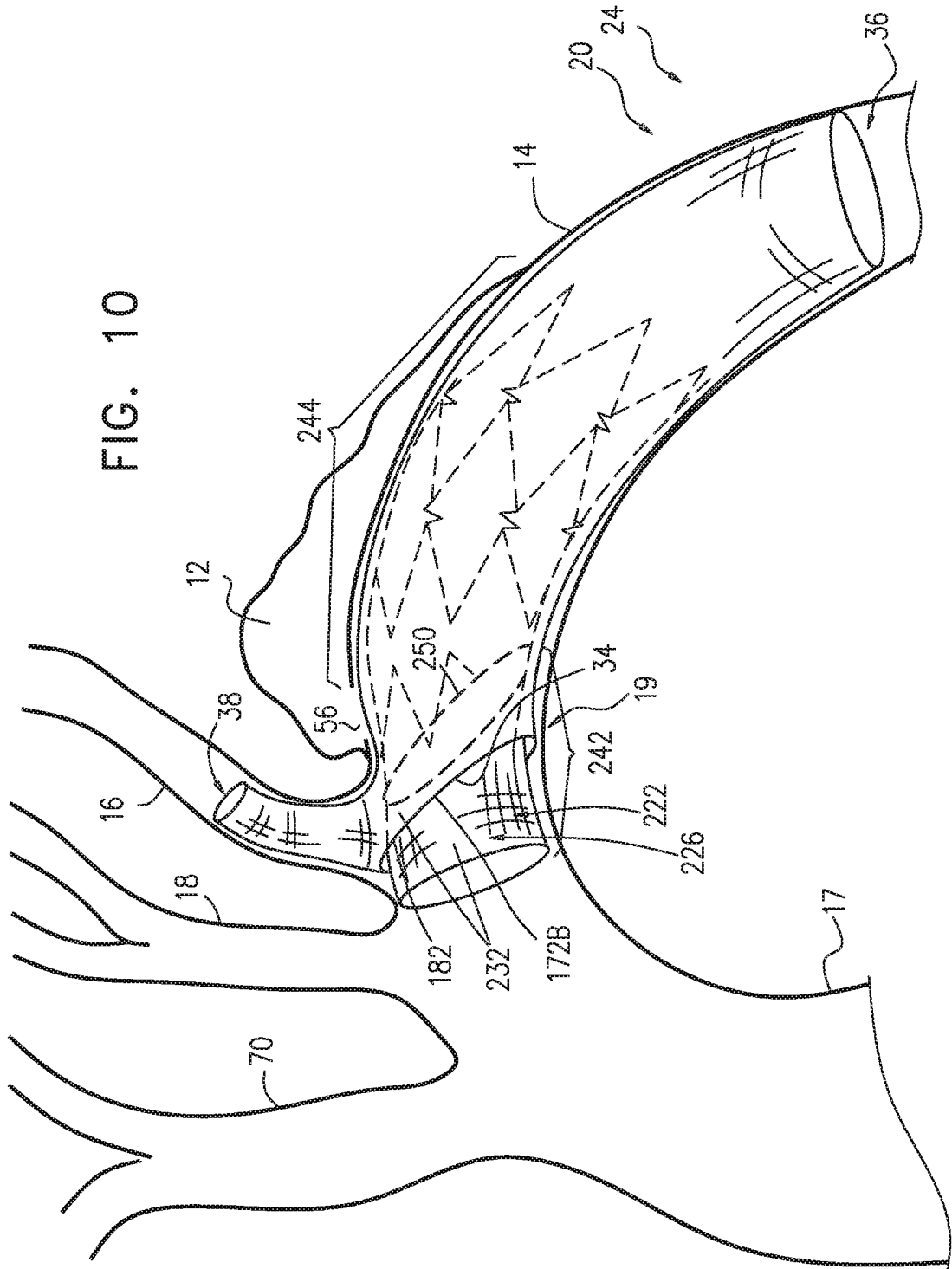

FIG. 11

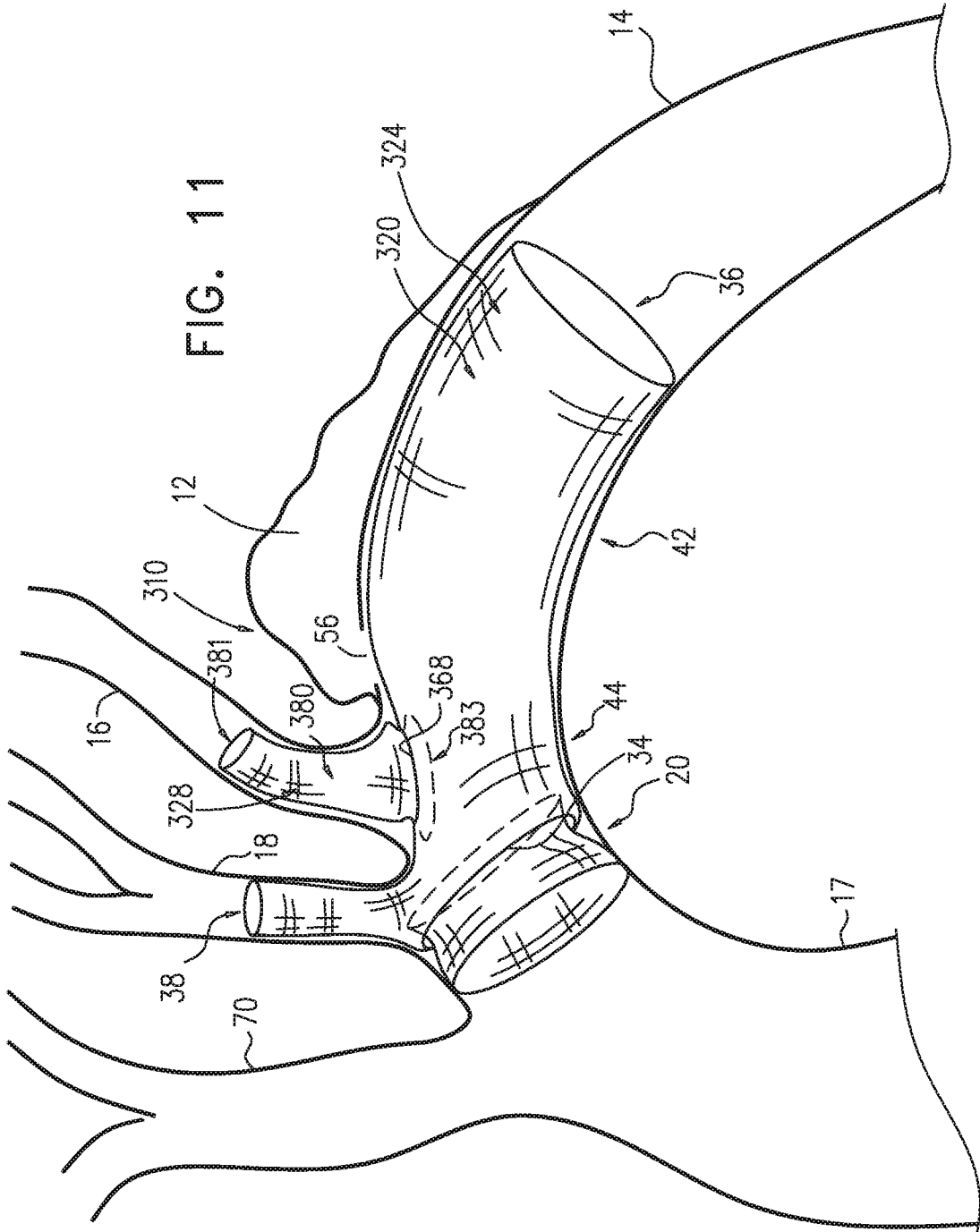

FIG. 12

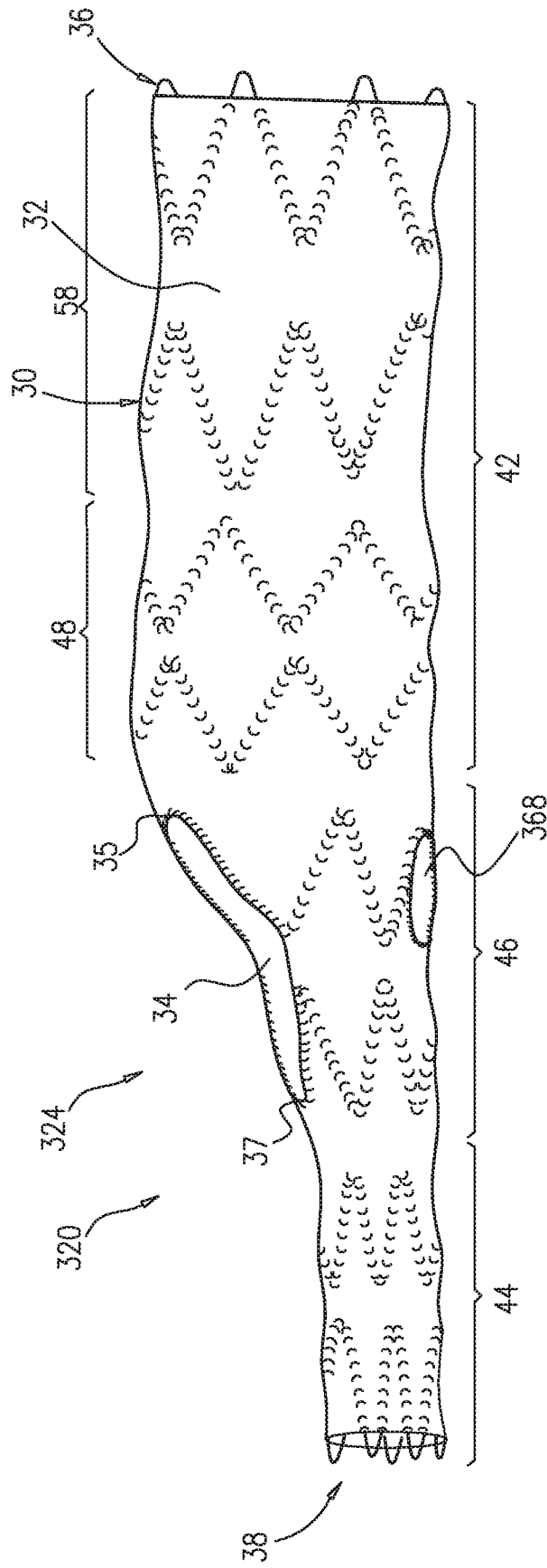

FIG. 13A

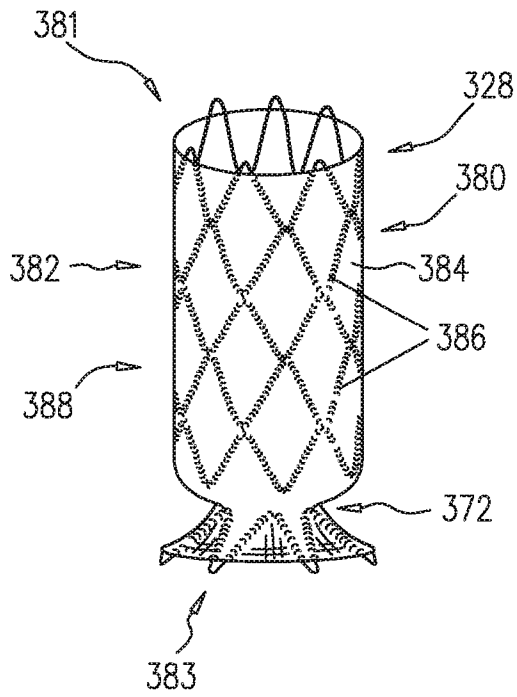
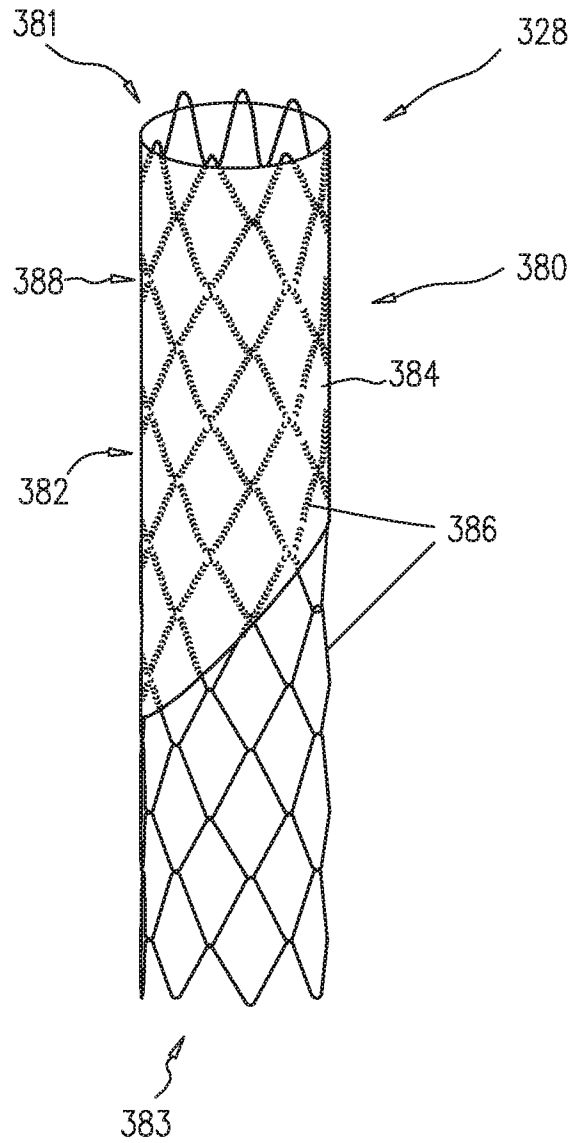

FIG. 13B



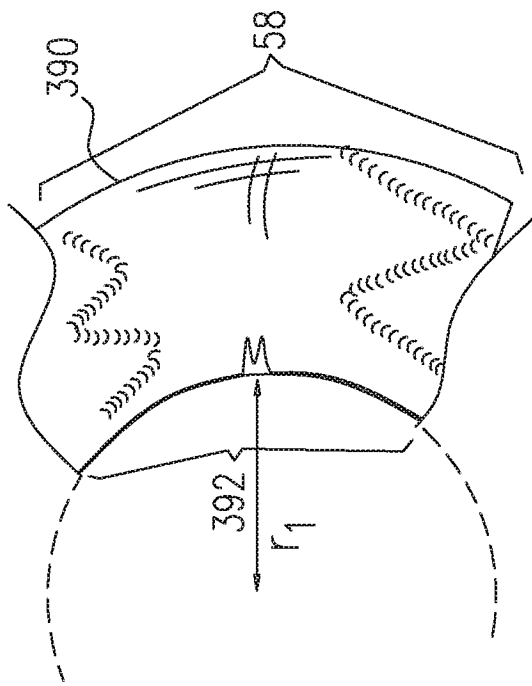

FIG. 14A

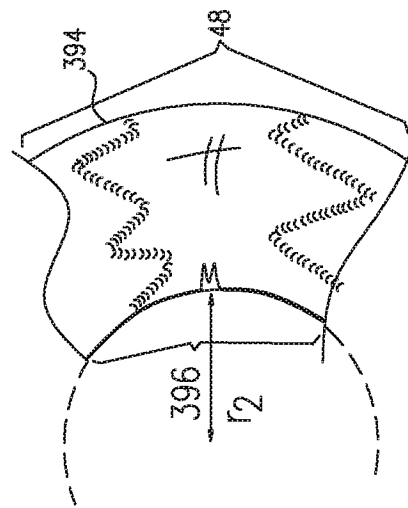

FIG. 14B

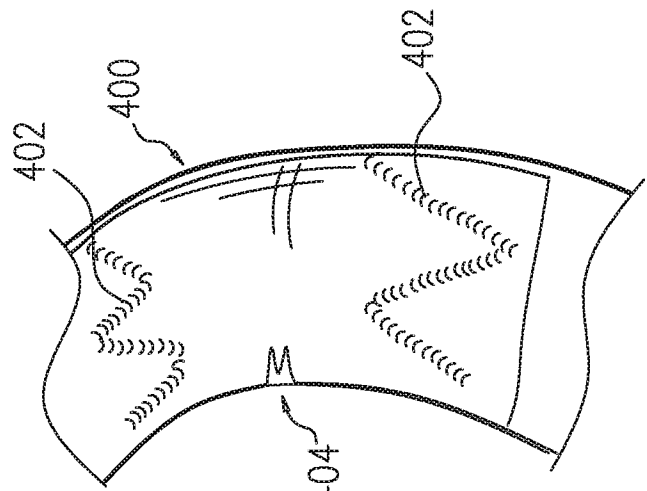

FIG. 15

INTERNATIONAL SEARCH REPORT

International application No.
PCT/IL 14/50174

A. CLASSIFICATION OF SUBJECT MATTER
 IPC(8) - A61F 2/07 (2014.01)
 USPC - 623/1.13, 1.15, 1.16, 1.31, 1.32
 According to International Patent Classification (IPC) or to both national classification and IPC

B. FIELDS SEARCHED
 Minimum documentation searched (classification system followed by classification symbols)
 IPC(8) - A61F 2/07 (2014.01)
 USPC - 623/1.13, 1.15, 1.16, 1.31, 1.32

Documentation searched other than minimum documentation to the extent that such documents are included in the fields searched
 623/1.15, 1.21, 1.3; 623/1.*
 (Search term limited; see below)

Electronic data base consulted during the international search (name of data base and, where practicable, search terms used)
 PubWest (PGPB, USPT, EPAB, JPAB); Google; PatBase (All);
 Search Terms: Fenestration, reinforce, stent, dissection, hole, opening, aperture, strengthen, strut, frame, structure, stiffness, size, thickness, aorta, subclavian, corodid, zone, area, section, portion, elasticity, modulus, tension, proximal, distal, diameter, radius, perimete

C. DOCUMENTS CONSIDERED TO BE RELEVANT

Category*	Citation of document, with indication, where appropriate, of the relevant passages	Relevant to claim No.
A	US 2010/0249899 A1 (CHUTER et al.) 30 September 2010 (30.09.2010) Entire document, especially Abstract, para[0036]- para[0040], para[0056] and FIGS. 1, 7.	1-27, 70-73
A	US 2009/0319022 A1 (HARTLEY et al.) 24 December 2009 (24.12.2009) Entire document, especially Abstract, para[0014], para[0042] and FIGS. 1, 6.	1-27, 70-73
A	US 2010/0161025 A1 (KUPPURATHANAM et al.) 24 June 2010 (24.06.2010) Entire document, especially Abstract, para[0096] and FIG. 8	1-27, 70-73
A	US 2009/0157014 A1 (OSBORNE et al.) 18 June 2009 (18.06.2009) Entire document, especially Abstract, para[0019], para[0027] and FIGS. 1, 5B.	1-27, 70-73
A	US 2011/0319983 A1 (ZHU et al.) 29 December 2011 (29.12.2011) Entire document, especially Abstract, para[0004]- para[0005], para[0025]- para[0033], para[0052] and FIG. 1, 4, 7.	1-27, 70-73
A	US 2008/0114446 A1 (HARTLEY et al.) 15 May 2008 (15.05.2008) Entire document.	1-27, 70-73
A	US 2007/0168018 A1 (AMPLATZ et al.) 19 July 2007 (19.07.2007) Entire document.	1-27, 70-73
A	US 2007/0067014 A1 (KE et al.) 22 March 2007 (22.03.2007) Entire document.	1-27, 70-73

Further documents are listed in the continuation of Box C.

* Special categories of cited documents:	
"A" document defining the general state of the art which is not considered to be of particular relevance	"T" later document published after the international filing date or priority date and not in conflict with the application but cited to understand the principle or theory underlying the invention
"E" earlier application or patent but published on or after the international filing date	"X" document of particular relevance; the claimed invention cannot be considered novel or cannot be considered to involve an inventive step when the document is taken alone
"L" document which may throw doubts on priority claim(s) or which is cited to establish the publication date of another citation or other special reason (as specified)	"Y" document of particular relevance; the claimed invention cannot be considered to involve an inventive step when the document is combined with one or more other such documents, such combination being obvious to a person skilled in the art
"O" document referring to an oral disclosure, use, exhibition or other means	"&" document member of the same patent family
"P" document published prior to the international filing date but later than the priority date claimed	

Date of the actual completion of the international search 01 July 2014 (01.07.2014)	Date of mailing of the international search report 30 JUL 2014
--	--

Name and mailing address of the ISA/US Mail Stop PCT, Attn: ISA/US, Commissioner for Patents P.O. Box 1450, Alexandria, Virginia 22313-1450 Facsimile No. 571-273-3201	Authorized officer: Lee W. Young PCT Helpdesk: 571-272-4300 PCT OSP: 571-272-7774
---	--

INTERNATIONAL SEARCH REPORT

International application No.

PCT/IL 14/50174

Box No. II Observations where certain claims were found unsearchable (Continuation of item 2 of first sheet)

This international search report has not been established in respect of certain claims under Article 17(2)(a) for the following reasons:

1. Claims Nos.:
because they relate to subject matter not required to be searched by this Authority, namely:

2. Claims Nos.:
because they relate to parts of the international application that do not comply with the prescribed requirements to such an extent that no meaningful international search can be carried out, specifically:

3. Claims Nos.: 28-30, 42-44
because they are dependent claims and are not drafted in accordance with the second and third sentences of Rule 6.4(a).

Box No. III Observations where unity of invention is lacking (Continuation of item 3 of first sheet)

This International Searching Authority found multiple inventions in this international application, as follows:

--- see extra sheet ---

1. As all required additional search fees were timely paid by the applicant, this international search report covers all searchable claims.
2. As all searchable claims could be searched without effort justifying additional fees, this Authority did not invite payment of additional fees.
3. As only some of the required additional search fees were timely paid by the applicant, this international search report covers only those claims for which fees were paid, specifically claims Nos.:

4. No required additional search fees were timely paid by the applicant. Consequently, this international search report is restricted to the invention first mentioned in the claims; it is covered by claims Nos.:
1-27, 70-73

Remark on Protest

- The additional search fees were accompanied by the applicant's protest and, where applicable, the payment of a protest fee.
- The additional search fees were accompanied by the applicant's protest but the applicable protest fee was not paid within the time limit specified in the invitation.
- No protest accompanied the payment of additional search fees.

INTERNATIONAL SEARCH REPORT

International application No.

PCT/IL 14/50174

----- Continuation of Box III: Observations where unity of invention is lacking (Continuation of item 3 of first sheet) -----

This application contains the following inventions or groups of inventions which are not so linked as to form a single general inventive concept under PCT Rule 13.1. In order for all inventions to be examined, the appropriate additional examination fees must be paid.

Group I: Claims 1-27, 70-73, drawn to a module (stent-graft) with a lateral fenestration and a method of implanting the module, further describing the structural aspects of the module

Group II: Claims 31-41, 45-69 and 74-78, drawn to a module (stent-graft) with a lateral fenestration and a second module, and a method of implanting the second module through the first module, further describing the structural aspects and installation methods of the second module

The inventions listed as Groups I - II do not relate to a single general inventive concept under PCT Rule 13.1 because, under PCT Rule 13.2, they lack the same or corresponding special technical features for the following reasons:

The features shared by the groups comprise, generally, a first module with a fenestration, and a method of installing the first module, but they fail to make a contribution over the prior art of US 2011/0319983 A1 to ZHU et al. (hereinafter: Zhu). Zhu describes the all shared features, specifically endovascularly introducing a main module, while in a radially-compressed state thereof (FIG. 4, 7, 1; para[0025]-[0033]), and positioning the main module such that (a) a proximal main-module end of the main module is positioned in a branch of an aortic arch selected from the group consisting of: a left subclavian artery left subclavian artery, and a left common carotid artery (FIG. 4, 7, para[0027],[0052], for the left subclavian artery, done in manner similar to FIG. 1 which is for brachiocephalic; para[0004]-[0005]), and (b) a distal main-module end of the main module is positioned in a descending aorta (para[0027],[0052], FIGS. 1, 4, 7; para[0004]-[0005]), wherein the main module includes a generally tubular main stent-graft (FIG. 4, 7, 1; para[0025]-[0033]), which includes (a) a main generally tubular support element, which includes main structural stent elements (stent segments, FIGS. 1, 4, 7; para[0006]), and (b) a main covering element that is attached to and at least partially covers the support element (graft FIGS. 1, 4, 7; para[0006]); thereafter, transitioning the main stent-graft to a radially-expanded state thereof, in which the main covering element and the main support element are shaped so as to together define a lateral fenestration that is disposed in the aortic arch, with the lateral fenestration facing upstream generally toward an ascending aorta (FIG. 4, 7, para[0027],[0052], for the left subclavian artery, done in manner similar to FIG. 1 which is for brachiocephalic; para[0004]-[0005]).

Consequently, Group I comprises specifics of the first module, while Group II comprises specifics of the second module. Neither of these special technical features is shared by the other group, nor do they correspond to a special technical feature in the other group. Accordingly, unity of invention is lacking under PCT Rule 13.1.