

609207

COMMONWEALTH OF AUSTRALIA

Form 1

Regulation 9

Patents Act 1952

APPLICATION FOR A STANDARD PATENT

WE, **BELOIT CORPORATION**, of 1 St. Lawrence Avenue, Beloit, Wisconsin 53511, United States of America hereby apply for the grant of a standard patent for an invention entitled **METHOD AND APPARATUS FOR PRETREATING AND DEBARKING LOGS** which is described in the accompanying complete specification.

The actual inventor of the said invention is: Eugene Egon KUTILIN

Our address for service is SMITH SHELSTON BEADLE, 207 Riversdale Road (P.O. Box 410), Hawthorn, Victoria, 3122 (Attorney Code SA)

Details of basic application:-

Number of Basic Application: 120,289  
Convention Country in which  
Basic Application was filed: United States of America  
Date of Basic Application: 12th November, 1987  
ISO Code: US

DATED THIS 8th DAY OF November, 1988

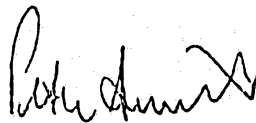

SMITH SHELSTON BEADLE

Patent Attorneys for the Applicants

TO: The Commissioner of Patents

Our Ref: PS:WB:5beloit.app

APPLICATION ACCEPTED AND AMENDMENTS

ALLOWED ..... 25 - 1 - 91

Forms 7 and 8

AUSTRALIAPatents Act 1952DECLARATION IN SUPPORT OF A CONVENTION OR NON-CONVENTION  
APPLICATION FOR A PATENT OR PATENT OF ADDITIONName(s) of  
Applicant(s)In support of the application made by BELOIT CORPORATION

Title

for a patent for an invention entitled "Method & Apparatus for Pretreating & Debarking Logs"Name(s) and  
address(es)  
of person(s)  
making  
declarationI/~~We~~, Dirk J. Veneman  
of 1 St. Lawrence Ave.  
Beloit, Wisconsin  
United States of America

do solemnly and sincerely declare as follows:-

1. I am/~~we are~~ the applicant(s) for the patent, or am/~~are~~ authorised by the abovementioned applicant to make this declaration on its behalf.
2. The basic application(s) as defined by Section 141 of the Act was/~~were~~ made in the following country or countries on the following date(s) by the following applicant(s) namely:-

Country, filing  
date and name  
of Applicant(s)  
for the or  
each basic  
applicationin U.S.A. on November 12 19 87  
by Eugene Egon KUTILIN  
in \_\_\_\_\_ on \_\_\_\_\_ 19 \_\_\_\_\_  
by \_\_\_\_\_

3. The said basic application(s) was/~~were~~ the first application(s) made in a Convention country in respect of the invention the subject of the application.

Name(s) and  
address(es)  
of the or  
each actual  
inventor

4. The actual inventor(s) of the said invention is/~~are~~ Eugene E. Kutilin  
2222 103rd Street  
White Rock, British Columbia V4A 5E7  
Canada

See reverse  
side of this  
form for  
guidance in  
completing  
this part

5. The facts upon which the applicant(s) is/~~are~~ entitled to make this application are as follows:-

the applicant is the assignee of the actual inventorDECLARED at Beloit, WI this 18th day of October 19 88

BELOIT CORPORATION

By: D. J. Veneman  
Dirk J. Veneman, Patent Counsel

This form may be completed and filed after the filing of a patent application but the form must not be signed until after it has been completely filled in as indicated by the marginal notes. The place and date of signing must be filled in. Company stamps or seals should not be used.

---

**(12) PATENT ABRIDGMENT (11) Document No. AU-B-24926/88**  
**(19) AUSTRALIAN PATENT OFFICE (10) Acceptance No. 609207**

---

- (54) Title  
METHOD AND APPARATUS FOR PRETREATING AND DEBARKING LOGS
- International Patent Classification(s)  
(51)<sup>4</sup> B27L 001/00
- (21) Application No. : 24926/88 (22) Application Date : 08.11.88
- (30) Priority Data
- (31) Number (32) Date (33) Country  
120289 12.11.87 US UNITED STATES OF AMERICA
- (43) Publication Date : 18.05.89
- (44) Publication Date of Accepted Application : 26.04.91
- (71) Applicant(s)  
BELOIT CORPORATION
- (72) Inventor(s)  
EUGENE E. KUTILIN
- (74) Attorney or Agent  
SMITH SHELSTON BEADLE, PO Box 410, HAWTHORN VIC 3122
- (56) Prior Art Documents  
US 3991800

(57) Another objection of the present invention is to provide a pretreatment apparatus which when associated with a debarker can be used for removing bark from all types of wood, and which operates at a high level of bark removing efficiency when processing short logs, frozen logs and logs of odd shape; eliminating the need for multiple debarking operations.

### CLAIM

1. An apparatus for removing a bark layer from a log comprising:
- a first cutting bed means for slitting the bark layer on the log in a first series of generally helical cuts;
  - a second cutting bed means for scoring the bark on the log in a second series of generally helical cuts;
  - said first and second cutting bed means being

oppositely facing and each having a plurality of parallel, spaced cutting members disposed relative to each other, so that said first and second sets of generally helical cuts intersect periodically around the log circumference, thereby defining discrete bark pieces of a size for convenient bark handling;

means for rolling logs between said beds with the longitudinal axes of said logs being disposed at an angle with respect to said cutting members, and

scraping means for dislodging the discrete bark pieces from the log.

14. An apparatus for pretreating a log prior to removing bark therefrom comprising:

first cutting bed means for slitting the bark;

second cutting bed means for slitting the bark in cuts intersecting with cuts made by said first cutting means;

said first and second cutting bed means being oppositely facing, and each bed including a plurality of parallel spaced cutting members disposed at an angle with respect to a log being pretreated;

means for causing relative movement between a log being pretreated and said first and second cutting means, causing the cuts made by said cutting means to surround the log.

18. A method for removing bark from a log comprising:  
scoring the log in a first set of substantially parallel helical cuts penetrating the bark layer;

scoring the log in a second series of generally

(11) AU-B-24926/88  
(10) 609207

-3-

parallel helical cuts penetrating the bark layer, said second series of cuts intersecting with said first series of cuts to define discrete bark pieces;

rolling the log between cutting means for simultaneously performing said first and second scoring steps;  
and

scraping the discrete bark pieces from the log.



This invention relates generally to the wood processing industry, and more specifically relates to a method and apparatus for pretreating logs before conventional debarkers, or for replacing conventional debarkers in removing bark from logs.

While generally having utility for removing bark from all log species, the invention is seen as having its greatest advantage for removing bark from log species normally considered to be difficult or troublesome to debark.

In many log utilizing industries, such as the papermaking industry, it is desirable to remove the bark from whole logs before further processing. In the past, several different types of debarkers have been used, generally groupable into three main categories based on the operating principles by which the bark is removed.

One general category of debarker, known as hydraulic debarkers, utilizes high pressure water jets to separate the bark from the log. Hydraulic debarkers include designs in which a single water jet traverses the log longitudinally, initially opening the bark layer. The log is rolled on its longitudinal axis, and the water jet used to separate the bark further around the circumference of the log, until the bark is completely separated from the log. In other types of hydraulic debarkers, a plurality of stationary or oscillating water jets are positioned around the circumference of a log, which traverses longitudinally, and the water jets separate the bark from the log.

While working well for some wood species and in some mill applications, hydraulic debarkers do not work well for species in which the bark is generally difficult to remove, and all hydraulic debarkers pre-

sent operational disadvantages, in that very large volumes of water are used, and must be treated after use. Thus, the environmental concerns for water treatment are significant, and the cost for equipment and for operating water treatment facilities can be high. Additionally, bark removed by hydraulic debarkers is wet and soggy; therefore, being difficult to handle after removal.

A second general category of debarker currently used is referred to as mechanical debarkers. In one type of mechanical debarker, a plurality of cutting tools are positioned around the circumference of the log, and the tools are rotated around the log as the log travels therebetween. The tools strip the bark from the log. This type of debarker is inefficient for short logs, and is generally prone to mechanical failure. Additionally, mechanical debarkers work well only for log species in which the bark readily fractures. Stringly types of bark tend to separate from the log in large sheets and wrap around the cutting tools, thereby making handling difficult.

In another type of mechanical debarker, the logs are positioned on two support rolls, and a cutting or grinding roll is positioned above the log. As the log is rolled, the roll grinds the bark from the log.

A third general category of debarker is known as a drum debarker, in which a large drum having surface elements on the inside thereof for cutting bark, receives a plurality of logs at one time. The drum is rotated to tumble the logs, and the surface elements remove the bark from the log. Drum debarkers normally are designed with slotted openings for bark to fall from the drum.

Mechanical debarkers and drum debarkers do not work well on severely bowed logs when cutting tool

contact along the log is restricted. In Northern climates, bark removal efficiency is reduced substantially when logs become frozen, regardless of the type of debarker being used. In some situations, it has been  
5 found necessary to subject logs to several consecutive debarking operations in order to achieve acceptable levels of bark removal.

Certain wood species present debarking difficulties. For example, eucalyptus, aspen, and other species  
10 at certain stages of log freshness or at certain times of the year actually debark too easily. The bark separates in large sheets, which clog debarking tools and generally are difficult to handle. In a drum debarker, bark from fresh eucalyptus will often accumulate in  
15 large balls that stay in the debarker and are removed therefrom only when the logs are removed. Apparatus must be provided to separate the bark pieces from the debarked logs, to ensure that the bark does not accompany the logs into subsequent log processing steps. In spite  
20 of these difficulties, drum debarkers are still most frequently used for eucalyptus, aspen and the like, in that the other types of debarkers are even less effective with these species than are the drum debarkers.

Handling bark removed from certain species is also  
25 difficult. The large bark sheets from eucalyptus can plug conveyors and will often intertwine in holding bins and adhere to each other, such that the entire bin of bark becomes a single mass. To alleviate this, separate bark handling process lines are often used, including chopping apparatus for reducing the size of the  
30 bark pieces. Such apparatus is expensive to obtain and is subject to clogging and mechanical failure during operation.

In the past, complicated pretreating devices have  
35 been used with some log species in an attempt to faci-

litate bark removal and handling; however, most such devices have generally been prohibitively expensive and operationally ineffective.

5 Accordingly an object of the present invention is to provide a method for debarking logs that overcomes many of the difficulties associated with debarking eucalyptus, aspen, and other wood species that present debarking problems.

10 Another objection of the present invention is to provide a pretreatment apparatus which when associated with a debarker can be used for removing bark from all types of wood, and which operates at a high level of bark removing efficiency when processing short logs, frozen logs and logs of odd shape; eliminating the need for multiple debarking operations.

15 Thus the invention in one form provides an apparatus for pretreating a log prior to removing bark therefrom comprising:

first cutting bed means for slitting the bark;

20 second cutting bed means for slitting the bark in cuts intersecting with cuts made by said first cutting means;

said first and second cutting bed means being oppositely facing, and each bed including a plurality of parallel spaced cutting members disposed at an angle with respect to a log being pretreated;

25 means for causing relative movement between a log being pretreated and said first and second cutting means, causing the cuts made by said cutting means to surround the log.

In another form the invention provides an apparatus for removing a bark layer from a log comprising:



a first cutting bed means for slitting the bark layer on the log in a first series of generally helical cuts;

a second cutting bed means for scoring the bark on the log in a second series of generally helical cuts;

said first and second cutting bed means being oppositely facing and each having a plurality of parallel, spaced cutting members disposed relative to each other, so that said first and second sets of generally helical cuts intersect periodically around the log circumference, thereby defining discrete bark pieces of a size for convenient bark handling;

means for rolling logs between said beds with the longitudinal axes of said logs being disposed at an angle with respect to said cutting members, and

scraping means for dislodging the discrete bark pieces from the log.

In a still further form the invention provides a method for removing bark from a log comprising:

scoring the log in a first set of substantially parallel helical cuts penetrating the bark layer;

scoring the log in a second series of generally parallel helical cuts penetrating the bark layer, said second series of cuts intersecting with said first series of cuts to define discrete bark pieces;

rolling the log between cutting means for simultaneously performing said first and second scoring steps; and

scraping the discrete bark pieces from the log.

In a preferred design useful in practicing the method



of the present invention, the top and bottom cutting elements are disposed in bed-like arrangements and the log is placed at one end of the lower bed. The upper bed is positioned above the log, only minimally overlapping the lower bed. After the log has been positioned on the lower bed, the upper bed is brought against the log with sufficient pressure to cause the cutting elements to pierce the bark layer. The upper bed is then advanced over the lower bed. The resultant movement is such that the log will roll between the beds and the angularly disposed cutting surfaces will score the log as described.

In order that the invention may be more readily understood reference should be made to the following detailed description and the accompanying drawings.

Figure 1 is a schematic illustration of a debarking process including the debarking apparatus of the present invention, as debarking of a log is begun.

Figure 2 is a schematic illustration of the debarking process of Figure 1, but showing the present debarking apparatus part way through the debarking procedure.

Figure 3 is a schematic illustration similar to the previous figures, depicting the debarking apparatus at completion of the debarking step.

Figure 4 is a schematic illustration similar to the previous figures, but illustrating the debarking



apparatus at the log loading step.

Figure 5 is a schematic illustration similar to the previous figures, depicting the debarking apparatus as the log loading step is completed, and just prior to commencement of bark removal.

Figure 6 is an enlarged, fragmentary cross-sectional view of the debarking apparatus shown in Figure 2, taken along line 6-6 of Figure 2.

Figure 7 is an enlarged top view showing the knife arrangement.

Figure 8 is an enlarged cross sectional view showing a particularly suitable knife embodiment for the present debarking apparatus, operating on a bowed log.

Figure 9 and 10 schematically illustrate basic control circuitry for the debarking apparatus.

Figure 11 is an enlarged view illustrating the bark scraping tool of the present invention.

Figure 12 illustrates a modified cutting assembly for the present debarking apparatus.

Figure 13 illustrates yet another embodiment of a suitable cutting apparatus for the present debarking apparatus.

Figure 14 is a schematic representation of a knife arrangement for the present debarking apparatus.

Figure 15 is an illustration of a log on which scoring lines are shown after processing through the present apparatus.

Referring now more specifically to the drawings, and to Figures 1 through 5 in particular, numeral 10 illustrates a debarking process in which a debarking apparatus 12 of the present invention is utilized for removing bark from logs designated by numerals 14a through j. The process apparatus further includes a log supply conveyor 16, and a singling conveyor 18

for supplying logs individually to the debarking apparatus 12. The conveyors 16 and 18 can be of any suitable design known to those skilled in the art, do not constitute a part of the present invention, and will not  
5 be described in more detail herein.

The debarking apparatus 12 includes an upper bed cutting assembly 20 and a lower bed cutting assembly 22. It should be recognized that the upper and lower bed assemblies 20 and 22 will be at least as wide as, and  
10 preferably slightly wider than the length of the longest logs to be debarked thereon. In the process depicted in Figures 1 through 5, individual logs are fed from the singling conveyor 18 to the debarking apparatus 12. A  
15 log positioner 24 pivotally connected at 26 is provided for receiving and positioning the log from the singling conveyor 18. The log positioner 24 may consist of a plurality of retaining arms located across the debarking apparatus, and should include at least positioners  
20 near each end of a log, and perhaps intermediate the log ends. The log positioner may take different forms, but should operate to catch and position the logs from the singling conveyor until the debarking operation commences, at which time the log positioner or positioners will be moved from the elevated position to a  
25 retracted position, thereby allowing the log to roll along the lower bed assembly. In this regard, the log positioner 24 can be spring-loaded, to be pushed out of the way by the rolling action of the log, or the retainer can be positively controlled to be moved out of  
30 the way through mechanical operation.

In the debarking apparatus 12, as illustrated in Figures 1 through 5, the lower bed cutting assembly 22 is stationary, and the upper bed cutting assembly 20 moves thereover, substantially parallel to the lower  
35 bed assembly, during operation of the apparatus. Each

of the upper and lower bed cutting assemblies 20 and 22 include a plurality of cutting edges 28 and 30, respectively, disposed in spaced relationship at locations across the longitudinal extent of the log. During operation, the cutting edges penetrate the bark layer circumferentially about the log as the log rolls. It will be recognized that as the upper bed cutting assembly moves toward the lower end of the lower bed cutting assembly the sliding motion will cause the log 14a to roll. Further details of the cutting edges will be described hereinafter.

As shown particularly in Figures 4 and 5, the upper bed cutting assembly 20 is operationally mounted to be raised out of the way during the log loading steps. It will be apparent to those skilled in the art that a suitable frame permitting translational movement of the upper bed over the lower bed can be provided, and the upper bed can be mounted on pneumatic, hydraulic, or other devices allowing it to be picked up for return movement to the upper end of the lower bed assembly. The design of the supporting frame work for the upper bed assembly will be one of design choice, and in and of itself does not constitute a part of this invention.

The upper and lower bed cutting assemblies 20 and 22 have been shown to be positioned at an angle with respect to the horizontal, and it is felt that such an orientation will be beneficial in the log loading and debarking process, in that the natural tendency of the logs to roll can be utilized. It should be recognized, however, that, in some applications, the beds may be disposed substantially horizontal, or at angles greater than or less than the angle shown in the drawings.

Referring now more specifically to Figures 6 and

7, the upper bed cutting assembly 20, lower bed cutting assembly 22, and cutting edges 28 and 30 will be described in more detail. As stated previously, a plurality of cutting edges 28 are provided in the upper bed assembly, and a plurality of cutting edges 30 are provided on the lower bed cutting assembly. The cutting edges depicted are sharpened edges on knives 32 and 34 of upper and lower bed assemblies 20 and 22, respectively, and the knives are disposed at an angle with respect to the axis of a log as it is rolled through the debarking apparatus. The upper and lower knives are parallel, but are not vertically aligned. As the log rolls through the debarking apparatus, each knife penetrates the bark layer 36 and imparts a helical cut or slit in the bark. As a result of the angular orientation of the knives with respect to the movement of logs through the apparatus, and the vertical misalignment between the upper and lower knives, the helical slits imparted by the knives intersect at various locations about the circumference of the log. Thus, as more clearly shown in Figure 15, the upper and lower bed cutting assemblies operate cooperatively to create discrete, generally diamond shaped bark pieces separated from each other by the helical slits 38 and 40. The size of the bark pieces is controlled by the spacing between adjacent blades and the angle at which the blades are disposed relative to the direction of log movement. Therefore, a debarking apparatus of the present invention can be designed to provide optimal bark size for bark handling operations following the debarker, and may eliminate the need for bark hogging operations, or other steps necessary for reducing bark size for subsequent processing.

Although the knives shown in Figures 6 and 7 are depicted as being solid throughout their extent across the debarking apparatus, it may be desirable to provide

the knives as segmented sections, separately mounted. As shown in Figure 8, each blade segment can be adjustably mounted by springs 42 or the like, to permit vertical movement. This type of mounting is particularly advantageous for the debarking of irregular or bowed logs. It is also advantageous if the logs vary in diameter from one end thereof to the other. The vertical adjustability of the knives permits each to contact the log at the necessary location. It will be recognized that, in this regard, relatively short knife segments would be preferable to knives extending across the entire dimension of the upper or lower bed. Figure 8 illustrates how each knife can assume the proper vertical position for the log being debarked. An exaggerated bow is shown in a log 44 in Figure 8. Each knife can adjust upwardly or downwardly as a high or low surface of the log is presented.

In utilizing the present debarking apparatus, it is necessary only to roll the log one full rotation. After one revolution, each blade will have performed a helical slit about the log, intersecting with slits of adjacent knives, and slits made by knives from the opposite cutting bed assembly. Since it is likely that any debarking apparatus will receive logs of varying diameters, it is desirable to provide means for determining the log diameter and adjusting the operation of the apparatus to correspond to the log diameter. In Figure 9, a microprocessing unit 50 is shown operationally connected to a location sensing mechanism 52 for the upper bed cutting assembly. Sensing means can be provided for determining the location of the upper bed cutting assembly after it is brought into contact with the log. Since the lower bed cutting assembly is stationary, the distance between the upper bed cutting assembly and the lower bed cutting assembly can be cal-

culated, or, alternatively, the position of the upper  
bed cutting assembly with respect to its supporting  
frame work can be determined, and the circumference of  
the log calculated therefrom. Those skilled in the art  
5 will recognize that different types of sensing me-  
chanisms can be used, such as, for example, proximity  
switches, photoelectric sensors, or the like. Those  
skilled in the art will also recognize that other con-  
trols are desirable for sensing when a log has been pro-  
10 perly located against the log positioner 24, and when a  
processed log has been removed from the assembly. In  
Figures 9 and 10, a proximity switch 54 is shown for  
sensing when the log has been removed from the appara-  
tus. Operation of the supply conveyors and the debarker  
15 can be automated in response thereto. Alternatively,  
the device can be controlled manually.

To ensure complete circumferential scoring of the  
bark, it is desirable to slightly exceed one revolution  
of the log. Therefore, the translational operation of  
20 the upper bed cutting assembly over the lower bed  
cutting assembly can be limited to just slightly greater  
than the calculated log circumference. As shown in  
Figure 10, it is advantageous to limit operation to this  
distance, so that the greatest efficiency of log pro-  
25 cessing can be reached.

As described heretofore, the present apparatus  
scores the bark to define discrete diamond shaped bark  
pieces. Logs so pretreated can be passed to other de-  
barking apparatus, such as drum debarkers, ring de-  
30 barkers, or the like for actual bark removal. For tree  
species such as eucalyptus, aspen, and like which  
have stringy bark presenting debarking and bark  
handling difficulties as described previously herein,  
the present apparatus for pretreating the bark elimina-  
35 tes these problems. The bark pieces, once removed from

the log, are small and easily handled. The bark will not conglomerate in a drum debarker, as described previously, but will fall easily therefrom through the open spaces. Large sheets of bark will not accumulate in and around ring debarkers, and the operational efficiency of a ring or drum debarker in processing eucalyptus, aspen, and similar species, will be improved by using the present invention for pretreating the logs.

The present apparatus and method can, however, be adapted to also remove the bark, thereby eliminating the need for additional debarking apparatus. In Figure 11, a scraping tool 60 is illustrated, which operates against the log to dislodge the bark pieces therefrom. The scraping tool 60 can be similar to those used in ring debarkers, or the like, in which a spring 62 is provided to urge the tool against the log and under the bark. The tool 60 is pivotally mounted on a supporting member 64 at pivot point 66, and will be slidably mounted on supporting apparatus parallel to the knives. Thus, as the log rolls along the cutting bed assemblies, the scraping tool 60 will slide from one end of the knife to the opposite end of the knife, chipping the bark therefrom, as the log advances.

Knife-type cutting edges have been described for the upper and lower cutting bed assemblies previously herein; however, it should be recognized that other types of cutting mechanisms can be utilized. For example, Figure 12 illustrates a saw tooth edge 70 for one of the cutting devices, which may oscillate during operation, and Figure 13 illustrates a cutting chain 80 for one of the cutting assemblies. Appropriate driving mechanisms for the chain are not shown. The modifications shown in Figures 12 and 13 can be used to replace some or all of the knife-like edges, to perform the helical cuts; or, alternatively, the modifications can be

provided to grip rather than cut the bark. Placed between other cutting edges, a gripping edge or chain will aid in rolling the log as the upper bed is advanced.

5 Previously herein, the lower bed cutting assembly has been described to be stationary; however, it should be realized that the upper bed could be stationary and the lower bed movable or, alternatively, the upper and lower beds can be movable in opposite directions. As yet a further modification, the cutting assemblies can  
10 be stationary, and the log pulled therebetween by gripping chains, edges or other grabbing mechanisms similar to that described above, operating above or below the log. If stationary cutting edges are used, it is likely that a plurality of gripping and pulling  
15 chains similar to chain 80 would be required, positioned at various locations between cutting edges.

In the use and operation of a log pretreating and debarking apparatus of the present invention, and of the embodiment illustrated in Figures 1 through 5,  
20 logs are loaded on the supply conveyor 16 by a crane or the like, and are advanced to the singling supply conveyor 18. As shown in Figures 4 and 5, the upper bed cutting assembly 20 is elevated and out of the way during the log loading steps. A single log is advanced  
25 onto the lower bed cutting assembly and is retained and positioned by the log positioner 24. The upper bed cutting assembly is lowered against the log with sufficient force to cause the cutting edges 28 and 30 of the upper and lower bed cutting assemblies to penetrate the  
30 bark layer of the log. When appropriate sensing mechanisms are provided, the circumference of the log is calculated, and the upper bed assembly is moved parallel to the lower bed assembly, as shown in Figures 2 and 3. As the log is advanced in a rolling ac-  
35 tion, each of the cutting edges creates a helical slit

in the bark layer, intersecting with adjacent slits. When the upper bed cutting assembly has advanced a calculated distance related to the log circumference, forward advancement is stopped, and the upper bed cutting assembly is raised out of the way, permitting the log to roll from the lower bed cutting assembly onto conveyors or the like for subsequent handling.

5 cutting assembly is raised out of the way, permitting the log to roll from the lower bed cutting assembly onto conveyors or the like for subsequent handling.

If the apparatus is used as a preconditioning device, after being pretreated, the log is processed through a ring debarker, drum debarker, or the like for actual bark removal. As described previously, the present invention greatly facilitates and simplifies bark removal, eliminating many of the problems associated with eucalyptus, aspen, or the like. The present invention, whether used as a pretreater or as a total debarker, may eliminate the need for further bark handling apparatus, such as hoggers or the like, utilized to reduce bark size.

10 through a ring debarker, drum debarker, or the like for actual bark removal. As described previously, the present invention greatly facilitates and simplifies bark removal, eliminating many of the problems associated with eucalyptus, aspen, or the like. The present invention, whether used as a pretreater or as a total debarker, may eliminate the need for further bark handling apparatus, such as hoggers or the like, utilized to reduce bark size.

15 present invention, whether used as a pretreater or as a total debarker, may eliminate the need for further bark handling apparatus, such as hoggers or the like, utilized to reduce bark size.

If the present invention is used as a total debarker, as the log end reaches a knife end, the bark scraping tool 60 contacts the log and begins scraping the bark pieces therefrom. As the log advances, the scraping tool slides on its supporting frame along the respective knife with which it is associated.

20 barker, as the log end reaches a knife end, the bark scraping tool 60 contacts the log and begins scraping the bark pieces therefrom. As the log advances, the scraping tool slides on its supporting frame along the respective knife with which it is associated.

25 Normally, the scraping tools are provided on the lower bed, and the bark pieces will fall through the lower bed to be collected for further handling. After the log passes fully over a knife, the scraping tool returns to the knife end nearest the loading end of the apparatus.

30 the apparatus.

In processing frozen logs, or the like, in which bark removal may be difficult, it may be advantageous to provide a flow of electrical current to the knife edges, <sup>below the bark layer and preferably</sup> to be imparted to the interface between the bark layer and the log. The rapid heating of

35 between the bark layer and the log. The rapid heating of



the moisture in the interface will assist in separating the bark from the log.

5 The present invention will provide many process advantages. Since the bark cutting and scraping devices can adjust in position to respond to varying log surface configurations, bark removal efficiency, as measured by the percentage of bark removed, is high. The need for multiple debarking steps, in most instances, will be eliminated. If subsequent log handling process steps would be improved thereby, log sorting can be performed easily as logs are removed from the apparatus. If log diameter or circumference has been calculated, deflecting gates can direct different size logs to different process paths as the logs roll off the lower bed assembly.

10

15

While a preferred embodiment and several modifications of a bark pretreating and removing method and apparatus have been shown and described in detail herein, it should be recognized that various changes and modifications can be made without departing from the scope of the present invention.

20

The claims form part of the disclosure of this specification.

The claims defining the invention are as follows:

1. An apparatus for removing a bark layer from a log comprising:

a first cutting bed means for slitting the bark layer on the log in a first series of generally helical cuts;

a second cutting bed means for scoring the bark on the log in a second series of generally helical cuts;

said first and second cutting bed means being oppositely facing and each having a plurality of parallel, spaced cutting members disposed relative to each other, so that said first and second sets of generally helical cuts intersect periodically around the log circumference, thereby defining discrete bark pieces of a size for convenient bark handling;

means for rolling logs between said beds with the longitudinal axes of said logs being disposed at an angle with respect to said cutting members, and

scraping means for dislodging the discrete bark pieces from the log.

2. An apparatus for removing bark from a log, as defined in claim 1, in which said second bed is stationary and transport means is provided for said first bed to move said first bed over said second bed with a log therebetween.

3. An apparatus for removing bark from a log, as defined in claim 2, in which said cutting members are knives having sharpened edges.

4. An apparatus for removing bark from a log, as defined in claim 2, in which said cutting members are cutting chains.



5 5. An apparatus for removing bark from a log, as defined in claim 2, in which electric circuit means are provided operatively connected to said cutting members for imparting an electrical current below the bark layer of the log.

6. An apparatus for removing bark from a log, as defined in claim 2, in which said scraping means includes a plurality of scraping tools slidable along the cutting members.

10 7. An apparatus for removing bark from a log, as defined in claim 2, in which sensing means are provided for calculating the <sup>circumference</sup> ~~diameter~~ of a log to be debarked, and for controlling the length of movement of said first bed over said second bed in response thereto.

8. An apparatus for removing bark from a log, as defined in claim 2, in which said first and second beds are disposed at a downward angle to the horizontal in the direction of movement of the log.

20 9. An apparatus for removing bark from a log, as defined in claim 1, in which said cutting members are vertically, resiliently mounted for vertical adjustment responsive to the log surface.

25 10. An apparatus for removing bark from a log, as defined in claim 2, in which a log positioner is provided near one end of said second bed, for receiving and positioning a log thereon, and said log positioner is retractable to allow a log to roll thereover.

11. An apparatus for removing bark from a log, as defined in claim 10, in which said cutting members are knives



having sharpened edges, and said log positioner extends upwardly between said knives of said second bed.

12. An apparatus for removing bark from a log, as defined in claim 1 in which said means for rolling logs includes transport means gripping the log and pulling the log  
5 between said first and second cutting means.

13. An apparatus for removing bark from a log, as defined in claim 12 in which said transport means includes a chain revolving between at least some of said cutting members, said chain including apparatus for gripping a log.  
10

14. An apparatus for pretreating a log prior to removing bark therefrom comprising:

first cutting bed means for slitting the bark;

second cutting bed means for slitting the bark in cuts intersecting with cuts made by said first cutting means;  
15

said first and second cutting bed means being oppositely facing, and each bed including a plurality of parallel spaced cutting members disposed at an angle with respect to a log being pretreated;

means for causing relative movement between a log being pretreated and said first and second cutting means, causing the cuts made by said cutting means to surround the log.  
20

15. An apparatus for pretreating a log, as defined in claim 14, in which log positioning apparatus is provided for receiving and positioning a log on said second bed; and lifting apparatus connected to said first bed is provided for raising said first bed from the path of a log being loaded on said second bed.  
25



16. An apparatus for pretreating a log prior to removing the bark therefrom, as defined in claim 15, in which transport means are provided for moving said first bed substantially parallel to said second bed, with a log positioned therebetween, causing said log to roll along said second bed.

17. An apparatus for pretreating a log prior to removing bark therefrom, as defined in claim 15, in which gripping means are provided between said cutting members for grasping a log, and said gripping means are transportable from one end of said beds to another end of said beds for rolling the log between said beds.

18. A method for removing bark from a log comprising:  
scoring the log in a first set of substantially parallel helical cuts penetrating the bark layer;

scoring the log in a second series of generally parallel helical cuts penetrating the bark layer, said second series of cuts intersecting with said first series of cuts to define discrete bark pieces;

rolling the log between cutting means for simultaneously performing said first and second scoring steps; and

scraping the discrete bark pieces from the log.

19. A method for removing bark from a log, as defined in claim 18, wherein said cutting means comprises first and second cutting means and said log is received between the respective cutting means for performing said first and second scoring steps; and said first and second cutting means are moved relative to each other thereby causing said rolling of



said log therebetween.

20. A method for removing bark from a log, as defined in claim 18, including the step of providing an electrical charge below the bark layer.

5 21. A method for removing bark from a log, as defined in claim 18, and further including the steps of sensing and determining the circumference of a log from which the bark will be removed, and said rolling of the log between cutting means for simultaneously performing said first and second  
10 scoring steps further involves controlling the duration of said rolling step with respect to the circumference of the log.

15 22. A method for removing bark from a log, as defined in claim 18, including the step of transporting the log from said cutting means to separate apparatus for performing said scraping step.

23. A method for removing bark from a log, as defined in claim 18, wherein said scraping step is performed simultaneously with said scoring steps.

20 24. An apparatus for removing a bark layer from a log substantially as hereinbefore described with reference to the accompanying drawings.

25 25. An apparatus for pretreating a log prior to removing bark substantially as hereinbefore described with reference to the accompanying drawings.

26. A method for removing bark from a log substantially as hereinbefore described with reference to the accompanying drawings.

DATED this 20 December 1990

**SMITH SHELSTON BEADLE**

Fellows Institute of Patent Attorneys of Australia

Patent Attorneys for the Applicant:

5

**BELOIT CORPORATION**

5  
2  
3  
4

5  
6  
7



FIG. 1

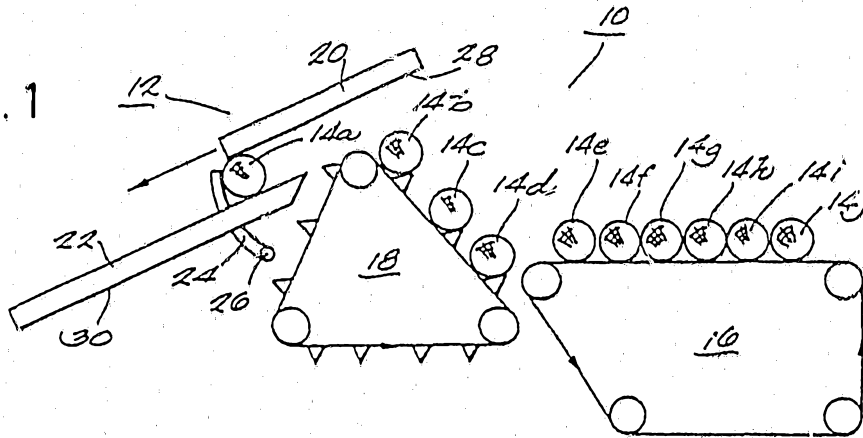

FIG. 2

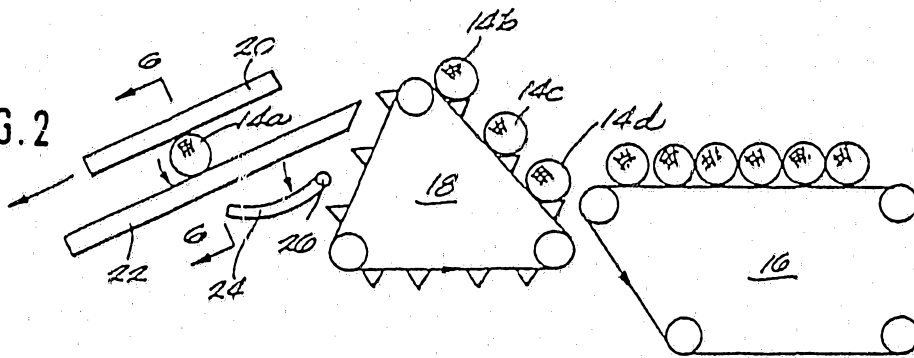

FIG. 3

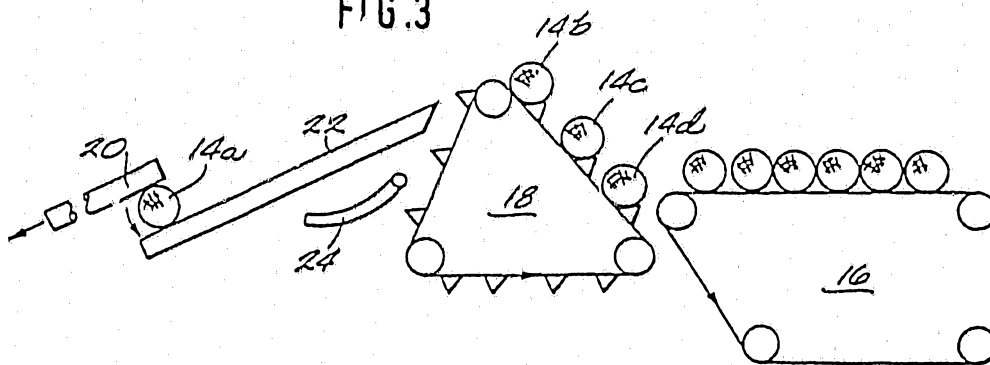

FIG. 4

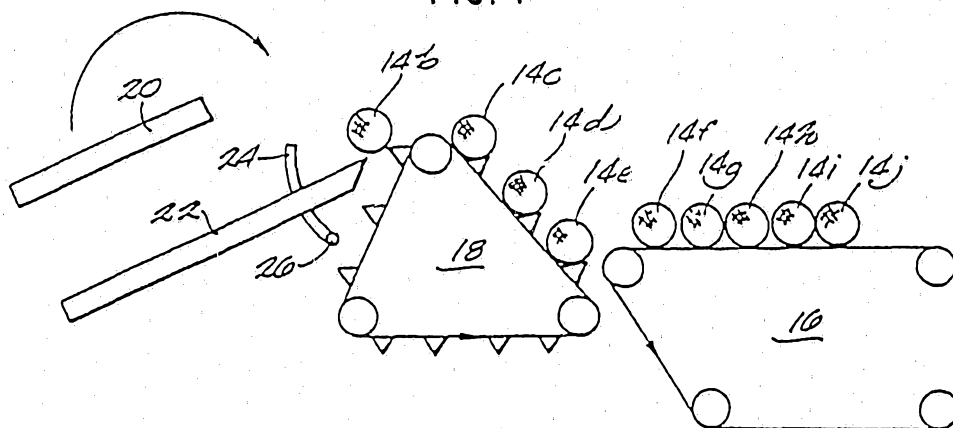
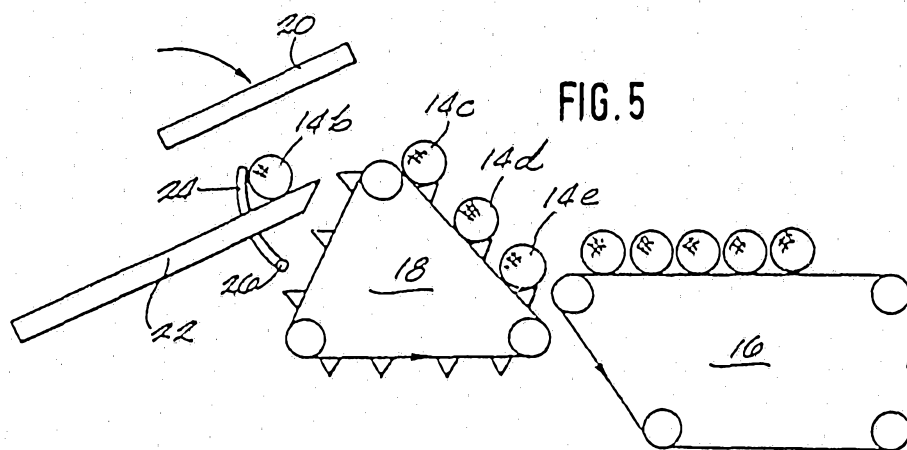

FIG. 5



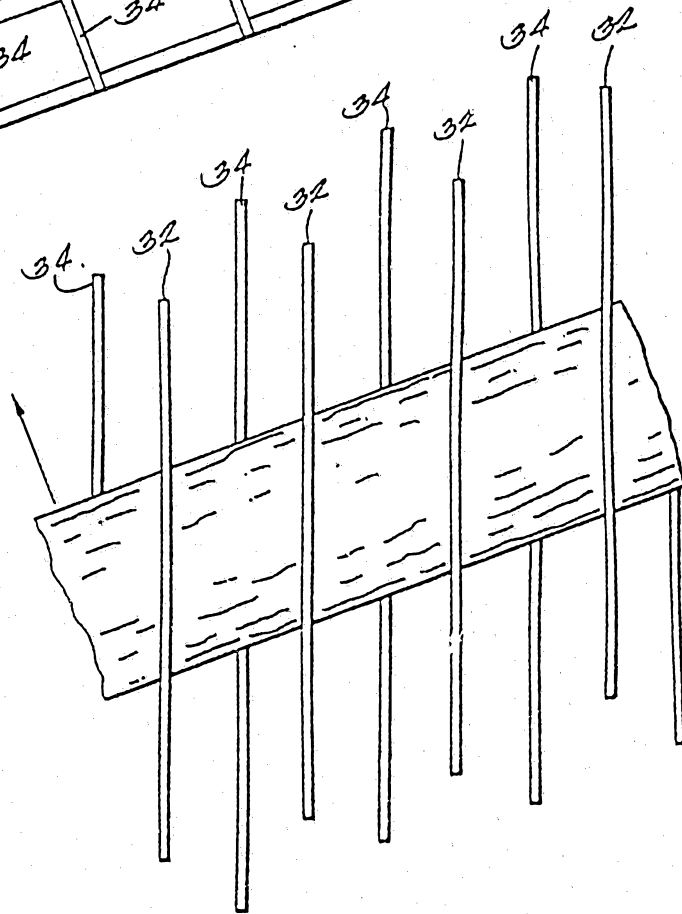
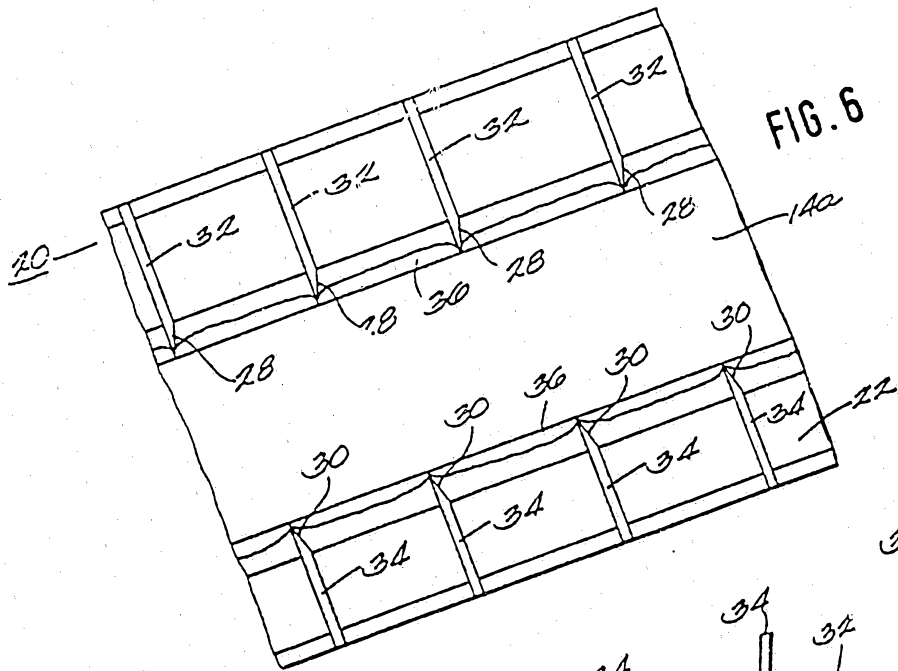

FIG. 8

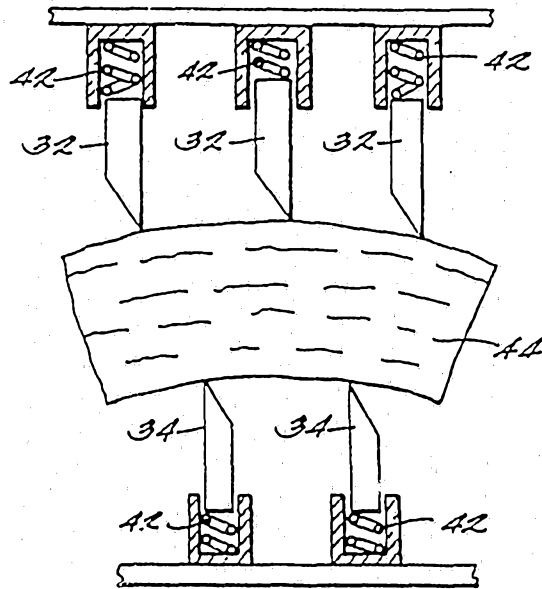

FIG. 9

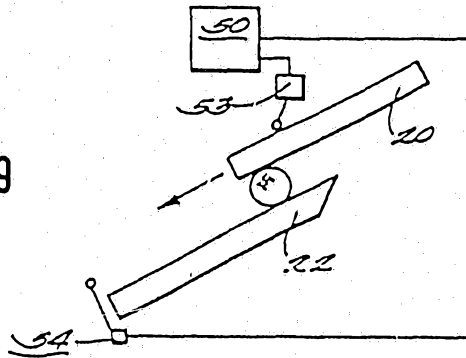
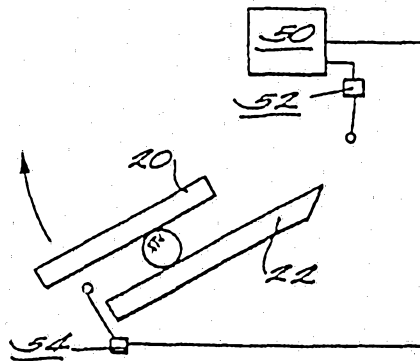
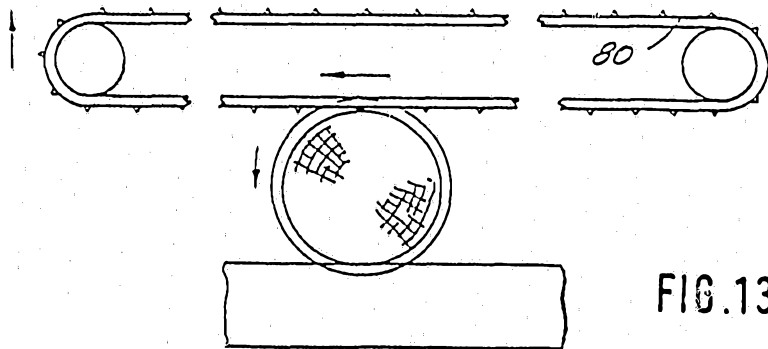
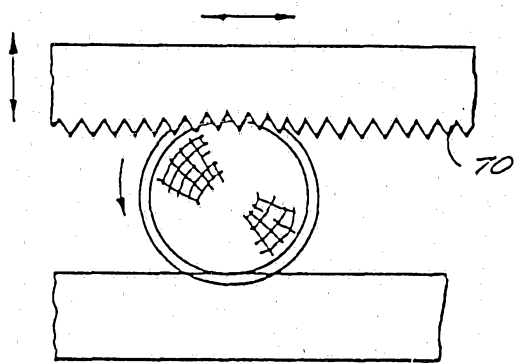
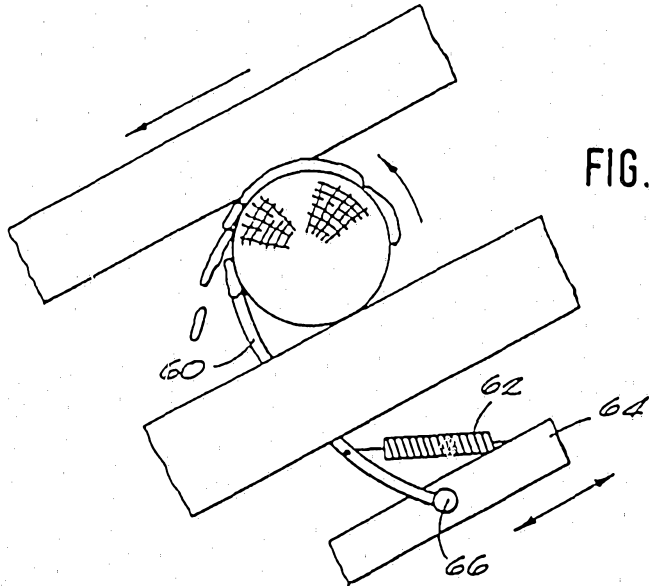

FIG. 10



24926/88



24926/88

FIG.14

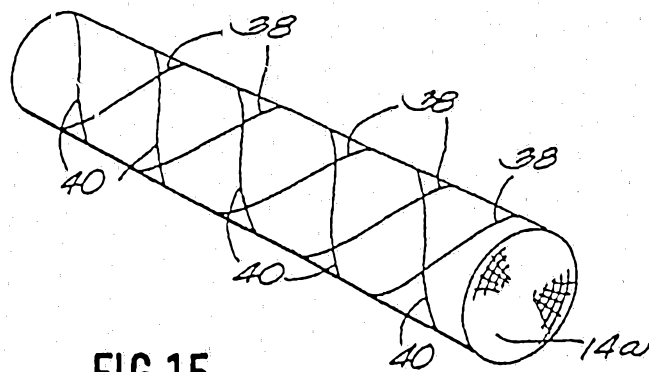
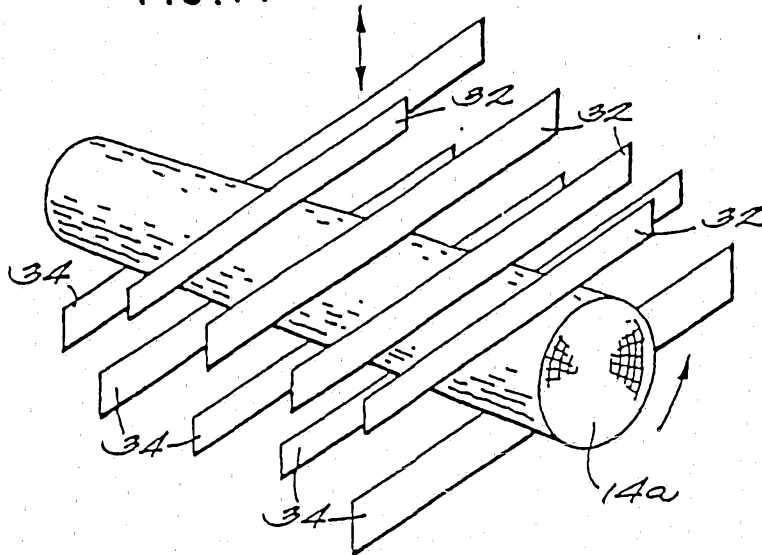

FIG.15