



INTERNATIONAL APPLICATION PUBLISHED UNDER THE PATENT COOPERATION TREATY (PCT)

<p>(51) International Patent Classification ⁶ : H01S 3/085, 3/105, 3/025, 3/25, G02B 26/08, G01D 5/26</p>	<p>A1</p>	<p>(11) International Publication Number: WO 95/13638 (43) International Publication Date: 18 May 1995 (18.05.95)</p>
<p>(21) International Application Number: PCT/EP93/03115 (22) International Filing Date: 8 November 1993 (08.11.93) (71) Applicant (for all designated States except US): INTERNATIONAL BUSINESS MACHINES CORPORATION [US/US]; Old Orchard Road, Armonk, NY 10504 (US). (72) Inventors; and (75) Inventors/Applicants (for US only): GERMANN, Roland [DE/CH]; Donnerweidstrasse 18, CH-8855 Wangen (CH). HAUSSER, Stefan [DE/CH]; Mythenstrasse 8, CH-8800 Tahlwil (CH). VETTIGER, Peter [CH/CH]; Langmoosstrasse 33, CH-8135 Langnau am Albis (CH). (74) Agent: BARTH, Carl, O.; International Business Machines Corp., Säumerstrasse 4, CH-8803 Rüschlikon (CH).</p>		<p>(81) Designated States: JP, US, European patent (AT, BE, CH, DE, DK, ES, FR, GB, GR, IE, IT, LU, MC, NL, PT, SE). Published <i>With international search report.</i></p>

(54) Title: HYBRID EXTERNAL COUPLED CAVITY SEMICONDUCTOR LASER DEVICE

(57) Abstract

This invention concerns a hybrid external coupled cavity semiconductor laser device with tunable wavelength. It uses a micromechanical, adjustable part (7, 17) integrated into a common support structure (3) bearing a semiconductor laser (1) and an external coupled cavity (2) functioning as an adjustable longitudinal mode filter. Positioning of said adjustable part (7, 17)

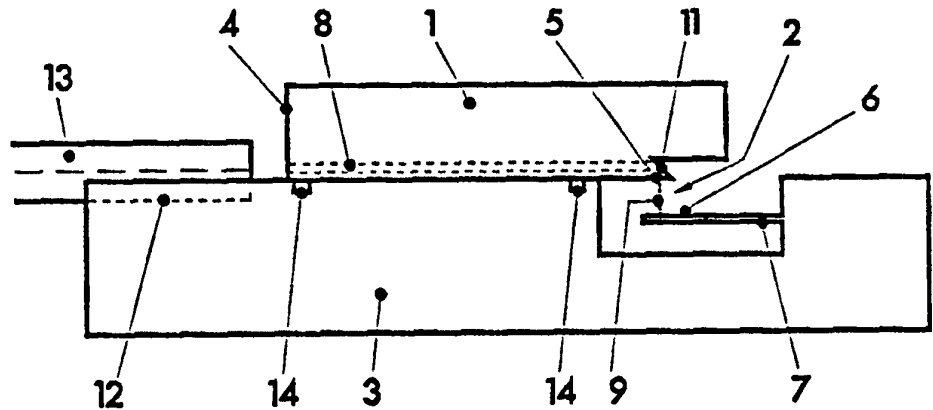

is preferably electrostatic, giving an approximately linear transfer function between the positioning voltage and the wavelength. Measuring sensors, wavelength multiplexing communication systems are envisioned as applications.

FOR THE PURPOSES OF INFORMATION ONLY

Codes used to identify States party to the PCT on the front pages of pamphlets publishing international applications under the PCT.

AT	Austria	GB	United Kingdom	MR	Mauritania
AU	Australia	GE	Georgia	MW	Malawi
BB	Barbados	GN	Guinea	NE	Niger
BE	Belgium	GR	Greece	NL	Netherlands
BF	Burkina Faso	HU	Hungary	NO	Norway
BG	Bulgaria	IE	Ireland	NZ	New Zealand
BJ	Benin	IT	Italy	PL	Poland
BR	Brazil	JP	Japan	PT	Portugal
BY	Belarus	KE	Kenya	RO	Romania
CA	Canada	KG	Kyrgystan	RU	Russian Federation
CF	Central African Republic	KP	Democratic People's Republic of Korea	SD	Sudan
CG	Congo	KR	Republic of Korea	SE	Sweden
CH	Switzerland	KZ	Kazakhstan	SI	Slovenia
CI	Côte d'Ivoire	LI	Liechtenstein	SK	Slovakia
CM	Cameroon	LK	Sri Lanka	SN	Senegal
CN	China	LU	Luxembourg	TD	Chad
CS	Czechoslovakia	LV	Latvia	TG	Togo
CZ	Czech Republic	MC	Monaco	TJ	Tajikistan
DE	Germany	MD	Republic of Moldova	TT	Trinidad and Tobago
DK	Denmark	MG	Madagascar	UA	Ukraine
ES	Spain	ML	Mali	US	United States of America
FI	Finland	MN	Mongolia	UZ	Uzbekistan
FR	France			VN	Viet Nam
GA	Gabon				

DESCRIPTION

Hybrid external coupled cavity semiconductor laser device

TECHNICAL FIELD

The present invention relates to semiconductor laser devices comprising a coupled external cavity. Proposed is a new and improved laser device with a stable wavelength which can be selected or changed at will according to intended use. Such use might be in fields like optical computing, optical communication, optical data transmission, optical measuring. Specifically, future high capacity optical data transmission networks using wavelength division multiplexing need light sources and receivers, whose wavelengths can be adjusted to one another and/or rapidly switched between different predetermined wavelengths. These applications are described e.g. in US 5 115 444 or US 5 191 625.

BACKGROUND OF THE INVENTION

Tunable semiconductor laser light sources of different types are already known, including multi-section distributed bragg-reflector lasers, as described e.g. in US 4 995 048, and external coupled cavity diode lasers, which may be found in WO 90/13161, US 5 023 885, or US 5 191 625. These are difficult to tune, since for tuning, one or more than a single parameter must be changed non linearly or interrelated.

An external coupled cavity laser has been realized as a hybrid device using a micropositionable mirror. Such a device is illustrated in IEEE J. Quant. Electronics, vol. QE-20, no.3, 3-1984, pages 223-229, J.P. van der Ziel et al., but

the device shown there is big and difficult to integrate in optoelectronic systems.

Diode lasers using an external coupled cavity for mode-stabilization are also known; their fabrication in a single monolithic structure is proposed in US 4 726 030 to simplify efficient batch processing. Further, US 5 115 444 describes in one embodiment a monolithic device which allows switching between different external coupled cavities.

External coupled cavity diode laser devices might function as light sources and/or detectors, as described e.g. in US 4 864 585 or US 4 803 695, including amplification of incoming light signals, useful in network nodes of optical communication systems, as known from US 5 191 625.

Micromechanically fabricated optical banks, mounts, or other support structures are already known for building hybrid optoelectronic microsystems with alignment aids, e.g. V-grooves or notches, and integrated electronic circuits. They allow integration of electrooptical components and electrostatic or other variation of their positions. Such optical banks may be found in WO 91/2392. The fabrication of micromechanical cantilevers, bridges, grooves, notches, and more complicated structures with a wide variety of micromachining techniques, e.g. selective etching, laser beam or charged particle beam machining, is well known, e.g. from *Microelectronic Engineering*, vol.3, 1985, pages 221-234, L. Csepregi.

It is a general object of this invention to avoid these different drawbacks of the prior art and to devise an easy to fabricate semiconductor laser device having adjustable wavelength. It is another object to provide a semiconductor laser device which is easy to tune or switch between different wavelengths within a range broader than heretofore provided. It is further intended to disclose a semiconductor laser device which is small, rugged and easily integratable into optical systems.

It is an object of this invention to propose a hybrid external coupled cavity semiconductor laser device comprising a conventional semiconductor laser and an external coupled cavity on a common support structure, the external coupled cavity acting as a longitudinal mode filter and being adjustable at will for switching or tuning the wavelength, an adjustable part of the external coupled cavity being integrated in the common support structure. A further object is to simplify fabrication of such devices by at least a micromachining step for integrating an adjustable part of the external coupled cavity in the common support structure.

Such hybrid external coupled cavity semiconductor laser devices may be used as light sources and/or detectors in optical systems.

They can also be used as transmitters and/or receivers for wavelength division multiplexing communication systems, e.g. for high capacity optical data transmission networks.

SUMMARY OF THE INVENTION

The above objects have been accomplished by integrating, in a common support structure, an adjustable part of an external coupled cavity. Coupled to a conventional semiconductor laser, the external cavity is adjustable at will and acts as a longitudinal mode filter for switching or tuning the wavelength accordingly.

As a result of the integration, such a hybrid external coupled cavity laser device may be miniaturized and easily integrated in various optoelectronic systems. It may be fast and easily tuned or switched, e.g. with a linear transfer function, over a broad range of wavelengths. Using micromachining for integration greatly simplifies the fabrication process and allows integration of other electronic, optic, fluidic or mechanic elements, or further miniaturization.

Additional aspects of this invention may contribute to further improved hybrid external coupled cavity semiconductor laser devices or to improved applicability or producibility of such devices. They can be useful alone or in combination depending on the intended use.

The adjustable part of the external coupled cavity can be formed in a single, in particular monolithic, support structure together with the common support structure. The adjustable part can also support a mirror and/or a light detector. Other adjustable parts may be useful to additionally adjust the external coupled cavity independently or for stabilizing the wavelength.

The adjustable part can be micropositioned, e.g. electrostatically by applying a voltage to it with respect to the support structure. Other micropositioning methods, e.g. thermo- or magneto-mechanic, hydraulic, or piezoelectric, may be used depending on the application.

The common support structure and/or the adjustable part of the external coupled cavity can be formed by micromachining. The support structure may comprise alignment aids, e.g. notches or V-grooves for supporting and aligning optical fibres that carry light to or from the device, or other optical elements. It may also comprise integrated optical or electronic elements.

The support structure may provide the anyhow necessary submount of the semiconductor laser, or a separate submount may be used. The support structure forms a support for a plurality, e.g. an array of such semiconductor laser devices of equal or different types. Semiconductor lasers of different types could be used, e.g. surface- or edge-emitting, mounted junction side up or junction side down, even directly grown on the support structure, with or without integrated deflectors, microlasers and others, which are subsumed as "conventional" semiconductor lasers, even if they are of very recent or yet unknown types. Certain other solid state microlasers might be useful, too. Such lasers may be of the types described in IEEE Photonics Technology

Letters, vol.4, no.7, 7-1992, pages 698-700, F.R.Gfeller et al. ; in Scientific American, 11-1991, pages 56-62, J.L. Jewell et al.; or in WO 91/02392.

BRIEF DESCRIPTION OF THE DRAWINGS

Embodiments of the invention are described in detail below with reference to the drawings (which are illustrative only and not to scale) to show more clearly the general inventive concept and additional aspects of the invention.

FIG. 1A,1B illustrate schematically a first and heretofore most preferred embodiment according to the invention.

The remaining figures illustrate different embodiments showing additional aspects of the invention, wherein

FIG. 2A,2B show two embodiments where deflection mirrors are omitted,

FIG. 3A,3B depict two more embodiments comprising separate deflection mirrors,

FIG. 4 illustrates a further embodiment comprising a vertical cavity surface emitting semiconductor microlaser,

FIG. 5A,5B illustrate an embodiment showing a rotationally movable mirror,

FIG. 6 shows another embodiment comprising an array of semiconductor laser devices, one of them adjustable,

FIG. 7 depicts still another embodiment comprising an array of semiconductor laser devices, each adjustable according to the invention.

DETAILED DESCRIPTION OF VARIOUS EMBODIMENTS
ACCORDING TO THE INVENTION

Figures 1A and 1B illustrate schematically in a partly sectional side view and a perspective view a first embodiment of the invention. A conventional semiconductor laser 1 is shown, mounted junction side down on a common support structure 3, in this embodiment a silicon submount required for such laser types, together with an adjustable external coupled cavity 2. An adjustable part 7, here a cantilever, is integrated in common support structure 3. The cantilever can be micromachined together with a hole by unisotropic etching well known in micromechanical arts. It supports a back-reflection mirror 6 of cavity 2. It may be coated with a conducting material and moved electrostatically by applying a voltage to it with respect to the rest of the submount. As is well known in micromechanical arts, other driving means, such as thermo- or magneto-mechanic, hydraulic or piezoelectric driving means may be used instead, but moving-mirror tuning together with electrostatic positioning gives a nearly linear transfer function between tuning voltage and adjusted wavelength. In an optical measuring or sensing device, the adjustable part may also be manipulated directly or indirectly by the variable to be measured. For example, a high voltage to be measured may be converted to a low voltage using a voltage dividing circuit and this low voltage is applied to the driving means. In an example of a temperature measuring device, thermal expansion may be used for manipulating the adjustable part. The cavity 2 is formed in this embodiment between back-reflection mirror 6 and a laser surface part 5 functioning additionally as one of the laser resonator mirrors. In this embodiment, laser 1 has one cleaved or etched mirror 4 and the other facet etched at a 45° angle with respect to the axis of the laser's active layer 8 to form an internal total reflection mirror 11, deflecting laser beam 9 onto the surface of the laser functioning as a second partially reflecting laser resonator mirror 5, and through said mirror and a narrow gap on back-reflection mirror 6 of cavity 2. Varying the narrow gap width adjusts cavity 2 and accordingly the wavelength of the tunable laser device. Additional aspects are shown in the embodiment

of Figures 1A,1B. At one end of the laser device, a V-groove 12 is formed, e.g. by micromachining steps as anisotropic etching, into the common support structure 3. Groove 12 supports and aligns an optical fibre 13 and improves coupling to the laser. Further alignment aids 14 may be integrated, e.g. pins, edges, notches, grooves or holes which serve in Figures 1A,1B to position the laser at a predefined place. Electrical contact pads and other electric or electronic elements are integrated, in this embodiment serving to drive laser or cantilever.

Figures 2A to 4 illustrate other embodiments according to the invention in a semblable schematic side view as Figure 1A. As is shown in Figures 2A,2B, deflection mirror (11 in Figure 1) can be dispensed with, depending on the chosen geometric layout. In Figure 2A, the laser 1 is mounted junction side up in a groove serving as an alignment aid 14. An adjustable cantilever carrying a back reflection mirror 6 of the external coupled cavity 2 projects down from an extension of the common support structure 3. Alignment aids 21 in form of abutments function to define end positions of said back reflection mirror, which may be tuned in the range or switched between said end positions. Clearly, these end positions may be adjustable, too. In Figure 2B, the adjustable cantilever projects up from the common support structure 3 and is formed monolithically with it, e.g. by micromachining. An abutment 21 defines the far-end position of the cantilever. Laser 1 is attached to the front side of common support structure 3 with help of alignment notches. Laser 1 may or may not contain a proper submount, for cooling and/or connecting purposes. Clearly, a common support structure like that of Figure 2B may be combined with a laser shown in Figure 1A incorporating a deflection mirror 11.

Figures 3A and 3B show separate deflection mirrors 16, positioned to deflect laser beam 9 on back reflection mirror 6. In Figure 3A, semiconductor laser 1 is directly grown on a common support structure 3 and a separate submount 19 is foreseen for cooling. Deflection mirror 16 is additionally adjustable, in this embodiment with help of a piezoelectric transducer 10. Alignment aids 14

help in positioning deflection mirror support 15 on common support structure 3. In Figure 3B, deflection mirror 16 is invariable and directly integrated in common support structure 3, e.g. deflection mirror support 15 may be monolithic with common support structure 3 and formed by micromachining methods. In Figure 3B, main parts of support structure 3 and laser 1 are not shown for simplicity.

Figure 4 illustrates the use of a vertical cavity surface emitting semiconductor microlaser 1 in an embodiment according to the present invention. Such a laser is mounted on a common support structure 3 using alignment edges 14. Beneath mirror 5 of laser 1, a hole is micromachined in support structure 3 which incorporates a cantilever as adjustable part 7 of an external coupled cavity 2 defined by back reflection mirror 6 and laser surface part 5.

Figures 5A and 5B schematically show a further embodiment according to the invention in top view and sectional front view taken along lines b-b. In this embodiment, not back reflection mirror 6 but deflection mirror 16 is adjustable due to the rotatable bridge-like adjustable part 17 of external coupled cavity 2. Such an adjustable part 17 may be monolithic with the common support structure. Depending on the rotational position of deflecting mirror 16 different parts 6¹ to 6⁴ of the back-reflection mirror 6 are selected, adjusting external coupled cavity 2. Abutment means may be provided to define one or more of said rotational positions, depending on the intended use. In the shown embodiment, an alignment aid 21 is used defining one end stop of the rotatable motion, allowing easy switching to a back-reflection mirror part 6¹. Back-reflection mirror 6 may consist of one or several pieces. Clearly, further optical elements may be incorporated into external coupled cavity 2 defining its optical length. Mirror support 18 may consist of one or several pieces, too, and may be monolithic with the support structure 3, or separate alignment aids (not shown) may be provided.

In Figures 6 and 7, two more embodiments according to the invention are shown schematically in top view (Figure 6) and sectional view (Figure 7),

respectively. Both illustrate a common support structure supporting a plurality of external coupled cavity semiconductor laser devices, at least one (but eventually many more) containing an adjustable part 7 for its external coupled cavity 2, said adjustable part being integrated into the common support structure 3.

Figure 6 illustrates that case for external coupled cavity semiconductor laser devices of a type similar to Figure 2B. Three semiconductor lasers are mounted side by side on a common support structure 3. Whereas outer devices have invariable back reflection mirrors 6^1 and 6^3 and invariable mirror supports 18^1 and 18^3 , a central device has an adjustable part 7 for its external coupled cavity 2, supporting related back reflection mirror 6^2 . As Figure 6 shows, the central device may be tuned in a range approximately given by outer, invariable devices.

In Figure 7, an example of a large array (maybe in one or more dimensions) of external coupled cavity laser devices is illustrated schematically using microlasers semblable to that shown in Figure 4. Microlasers of equal or different types, with equal or different wavelengths may be used according to the intended application. In Fig. 7, a case is illustrated where all devices are adjustable having each an adjustable part 7^1 to 7^n supporting a back-reflection mirror 6^1 to 6^n of the related external coupled cavity 2^1 to 2^n . A microlaser array is built on a substrate 20 and different lasers 1^1 to 1^n are separated by deep grooves, e.g. micromachined by etching. Afterwards, the laser array is mounted on a common support structure 3 containing a micromachined cantilever for each device. Again, alignment aids 14 may help positioning the laser array with respect to the common support structure 3.

As should be clear from the foregoing detailed description, numerous modifications depending on the intended use could be made in accord with the general concept of the invention; all these different embodiments fall within the scope of said concept for a person skilled in the art.

CLAIMS

1. Semiconductor laser device comprising at least one semiconductor laser (1), an external cavity (2) coupled to said semiconductor laser (1), and a common support structure (3) supporting at least said semiconductor laser (1) and said external cavity (2), said external cavity (2) being adjustable at will, characterized by an adjustable part (7,17) of said external cavity (2) being integrated in said common support structure (3).
2. Semiconductor laser device according to claim 1, wherein said common support structure (3) and/or said adjustable part (7,17) consist(s) of one or more micromechanical parts.
3. Semiconductor laser device according to claim 2, wherein said common support structure (3) and said adjustable part (7,17) form a single monolithic structure.
4. Semiconductor laser device according to claim 1, wherein said adjustable part (7,17) is a cantilever or bridge supporting a mirror and/or a light detector.
5. Semiconductor laser device according to claim 4, comprising means to position said cantilever or bridge (7,17) electrostatically.
6. Semiconductor laser device according to claim 1, comprising at least one deflecting mirror (11,16) deflecting light to/from said adjustable part (7,17).
7. Semiconductor laser device according to claim 2, comprising at least one V-groove (12) for supporting and aligning optical elements, in particular an optical fibre (13) carrying light to or from said semiconductor laser device.

8. Semiconductor laser device according to claim 1, wherein said common support structure (3) bears a plurality of said semiconductor laser devices.
9. Semiconductor laser device according to claim 1, wherein said external coupled cavity (2) comprises further means to adjust laser wavelength.
10. Semiconductor laser device according to claim 1, wherein said external coupled cavity (2) functions as adjustable longitudinal mode filter.
11. Use of a semiconductor laser device according to any of the preceding claims for tuning or switching the laser's wavelength.
12. Use of a semiconductor laser device according to any of the preceding claims as transmitter and/or receiver in wavelength division multiplexing systems.
13. Use of a semiconductor laser device according to claim 12, wherein said wavelength division multiplexing systems is part of high capacity optical data transmission networks.
14. Use of a semiconductor laser device according to claims 1 to 10 as an optical sensor, wherein variables to be measured directly or indirectly manipulate said adjustable part (7,17).
15. Method of forming a semiconductor laser device according to claims 1 to 10, characterised by micromachining a single monolithic structure forming at least said common support structure (3) and said adjustable part (7,17) of said external coupled cavity (2).

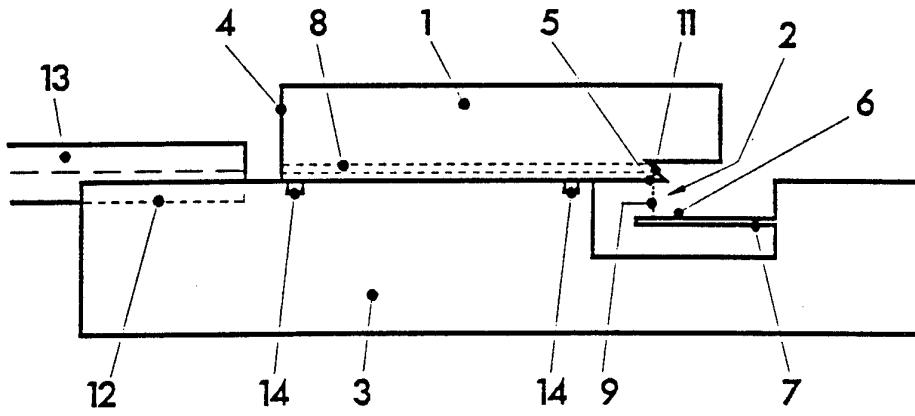

FIG. 1A

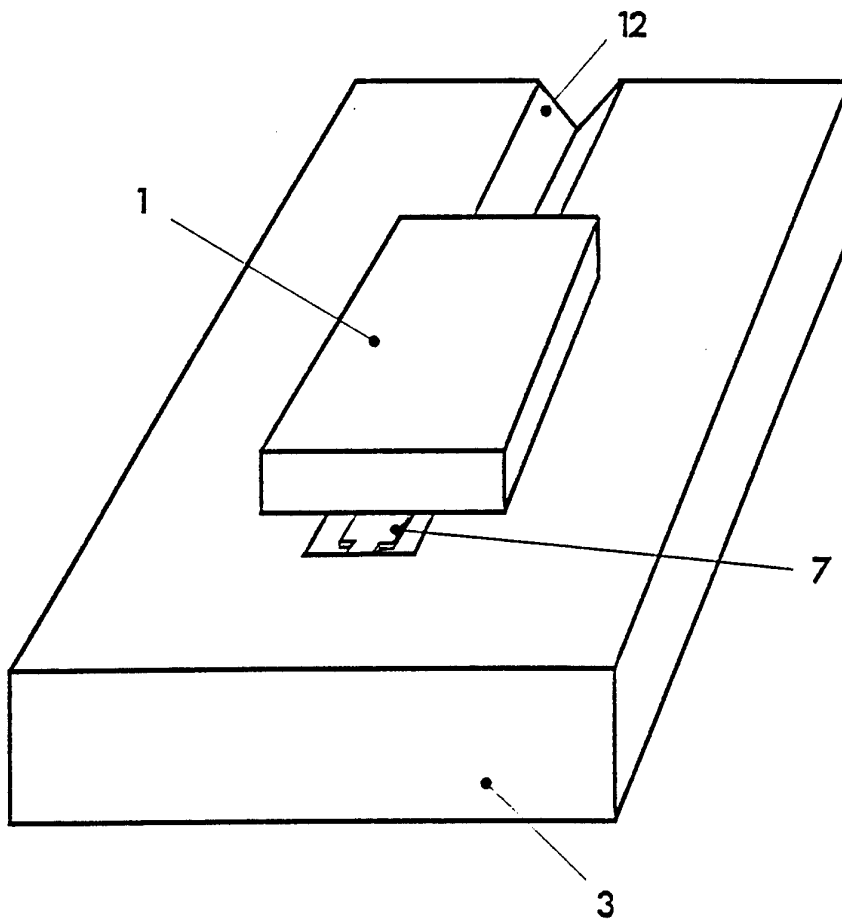

FIG. 1B

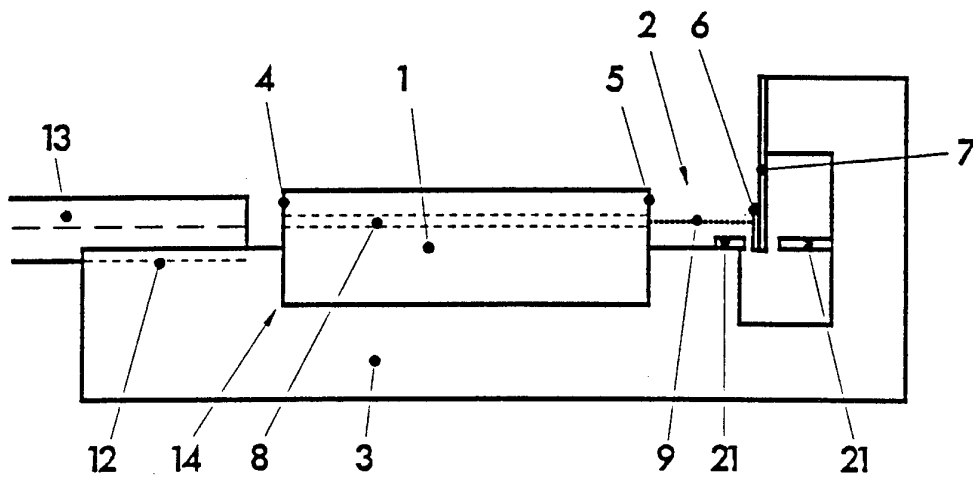

FIG. 2A

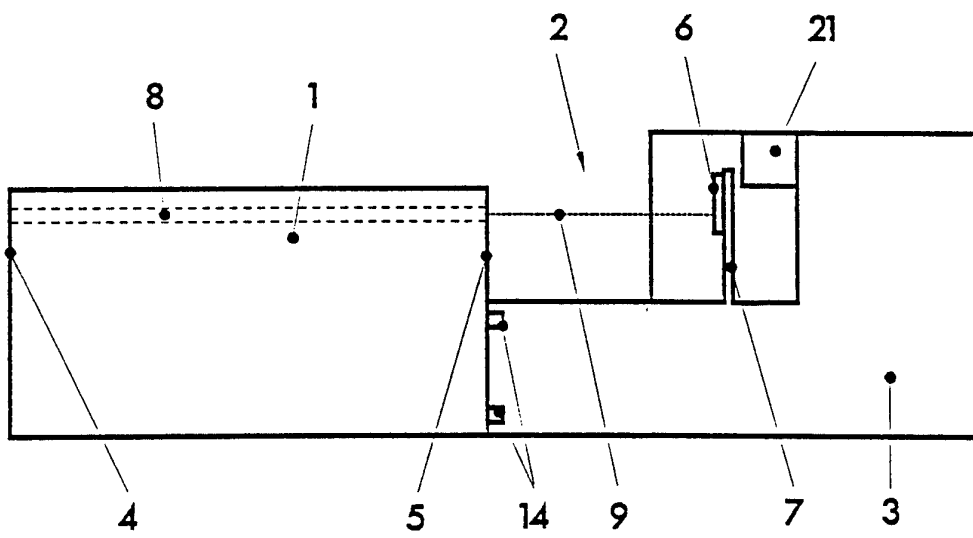

FIG. 2B

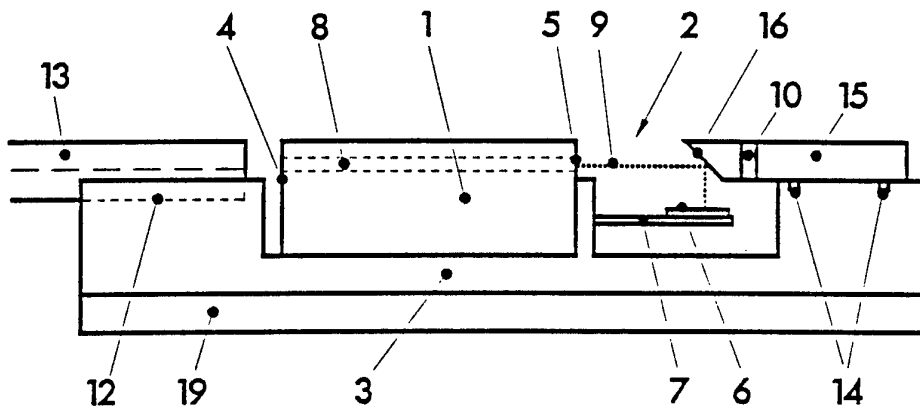

FIG. 3A

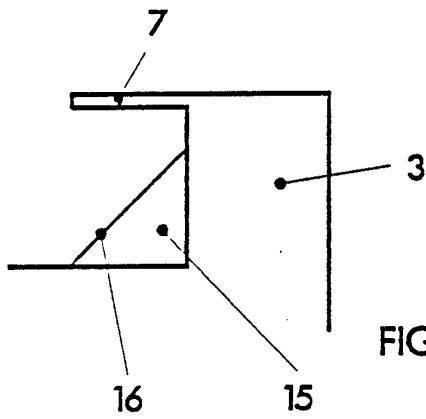

FIG. 3B

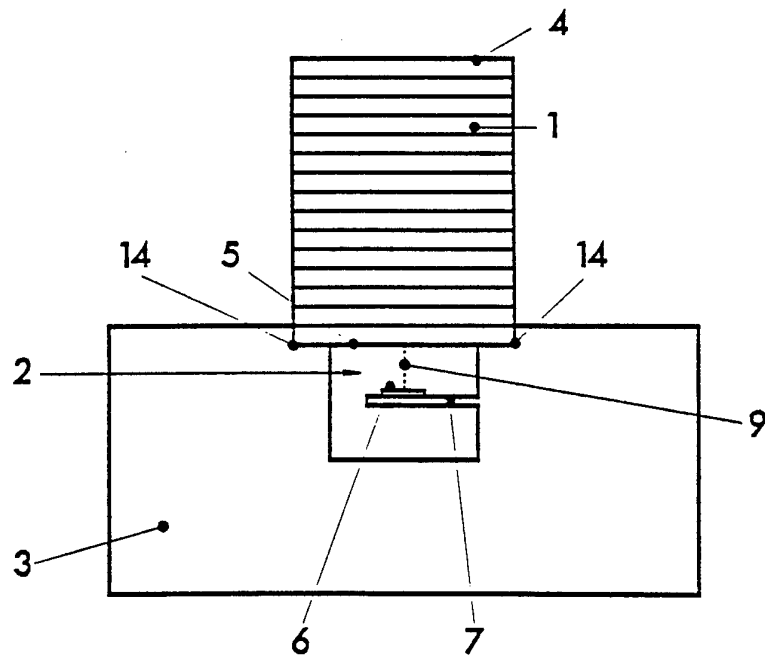

FIG. 4

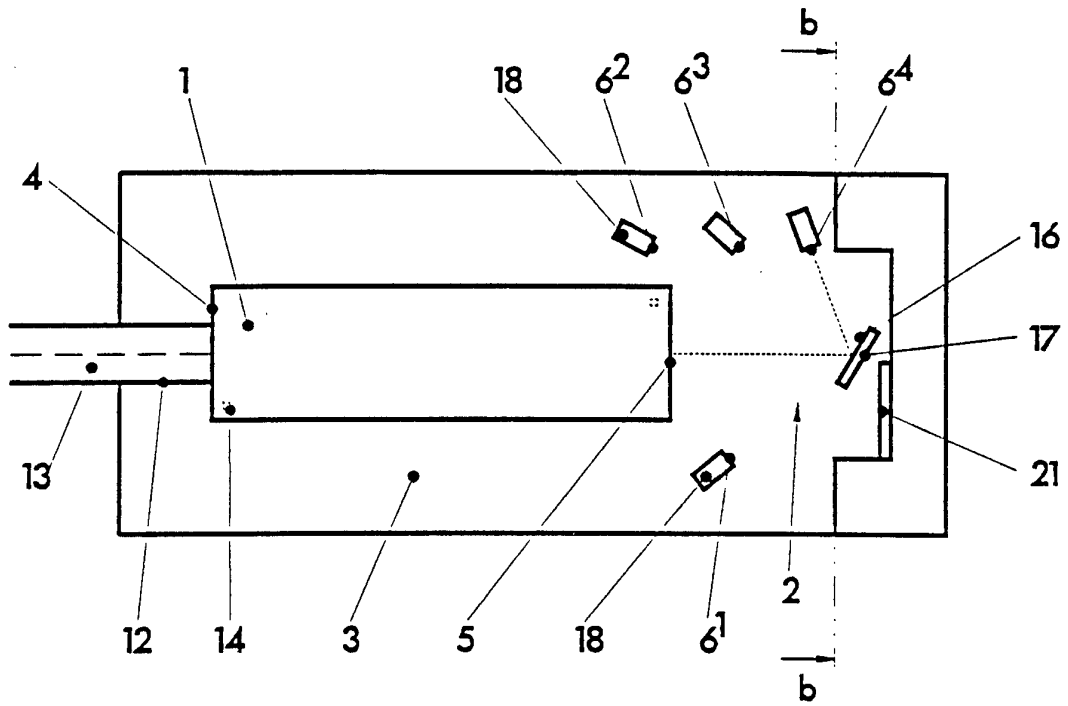

FIG. 5A

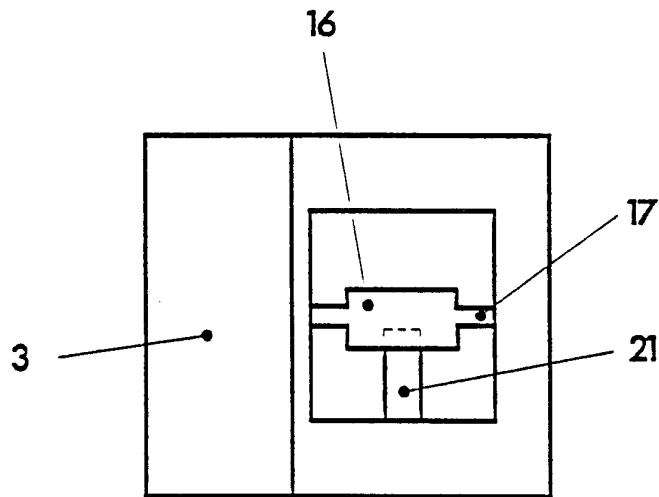

FIG. 5B

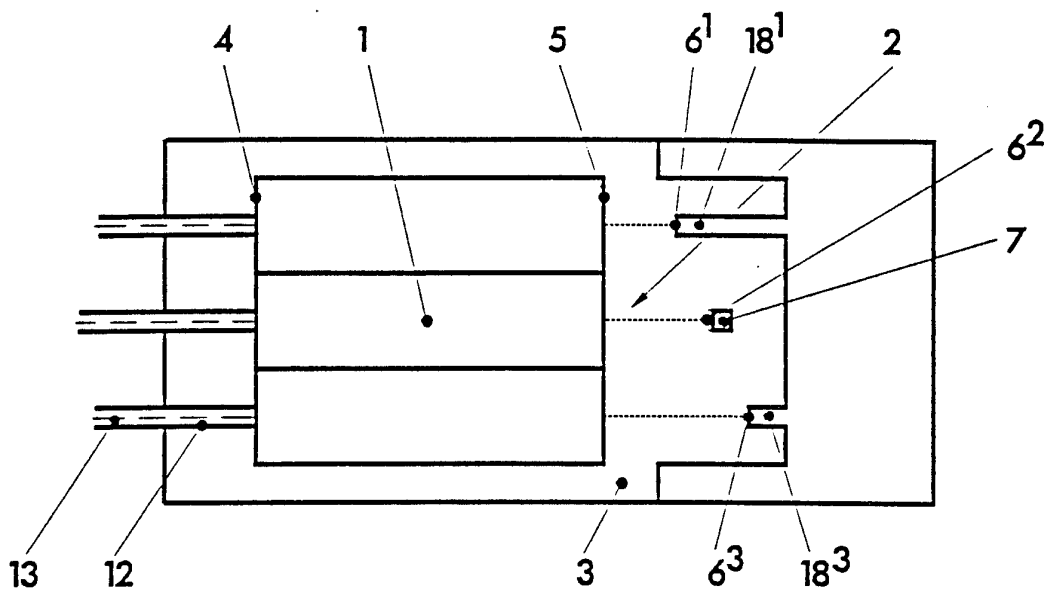

FIG. 6

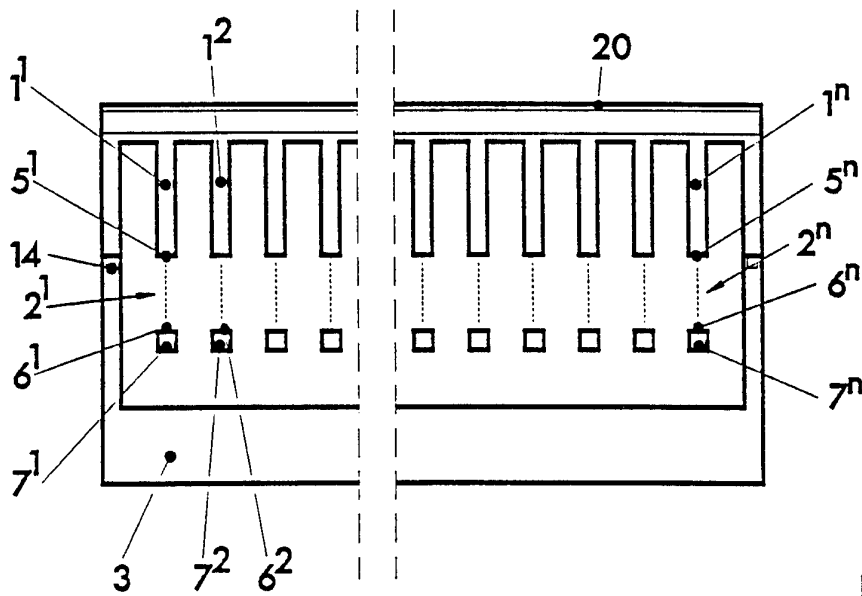

FIG. 7

INTERNATIONAL SEARCH REPORT

International Application No
PCT/EP 93/03115

A. CLASSIFICATION OF SUBJECT MATTER IPC 6 H01S3/085 H01S3/105 H01S3/025 H01S3/25 G02B26/08 G01D5/26				
According to International Patent Classification (IPC) or to both national classification and IPC				
B. FIELDS SEARCHED				
Minimum documentation searched (classification system followed by classification symbols) IPC 6 H01S G02B G01D				
Documentation searched other than minimum documentation to the extent that such documents are included in the fields searched				
Electronic data base consulted during the international search (name of data base and, where practical, search terms used)				
C. DOCUMENTS CONSIDERED TO BE RELEVANT				
Category ^o	Citation of document, with indication, where appropriate, of the relevant passages	Relevant to claim No.		
X	SCIENCE, vol.260, 7 May 1993, LANCASTER, PA US pages 786 - 789 H. UKITA ET AL 'A photomicrodynamic system with a mechanical resonator monolithically integrated with laser diodes on gallium arsenide'	1-4, 9-11,14, 15		
A	see the whole document	5,8,12, 13		
X	OPTICS COMMUNICATIONS., vol.93, no.1/2, 15 September 1992, AMSTERDAM NL pages 82 - 86 P.A. RUPRECHT ET AL 'Enhanced diode laser tuning with a short external cavity'	1,2,9-11		
A	see the whole document	3,4,12, 13		
--- -/--				
<input checked="" type="checkbox"/> Further documents are listed in the continuation of box C. <input checked="" type="checkbox"/> Patent family members are listed in annex.				
^o Special categories of cited documents : <table border="0" style="width: 100%;"> <tr> <td style="width: 50%; vertical-align: top;"> "A" document defining the general state of the art which is not considered to be of particular relevance "E" earlier document but published on or after the international filing date "L" document which may throw doubts on priority claim(s) or which is cited to establish the publication date of another citation or other special reason (as specified) "O" document referring to an oral disclosure, use, exhibition or other means "P" document published prior to the international filing date but later than the priority date claimed </td> <td style="width: 50%; vertical-align: top;"> "T" later document published after the international filing date or priority date and not in conflict with the application but cited to understand the principle or theory underlying the invention "X" document of particular relevance; the claimed invention cannot be considered novel or cannot be considered to involve an inventive step when the document is taken alone "Y" document of particular relevance; the claimed invention cannot be considered to involve an inventive step when the document is combined with one or more other such documents, such combination being obvious to a person skilled in the art. "&" document member of the same patent family </td> </tr> </table>			"A" document defining the general state of the art which is not considered to be of particular relevance "E" earlier document but published on or after the international filing date "L" document which may throw doubts on priority claim(s) or which is cited to establish the publication date of another citation or other special reason (as specified) "O" document referring to an oral disclosure, use, exhibition or other means "P" document published prior to the international filing date but later than the priority date claimed	"T" later document published after the international filing date or priority date and not in conflict with the application but cited to understand the principle or theory underlying the invention "X" document of particular relevance; the claimed invention cannot be considered novel or cannot be considered to involve an inventive step when the document is taken alone "Y" document of particular relevance; the claimed invention cannot be considered to involve an inventive step when the document is combined with one or more other such documents, such combination being obvious to a person skilled in the art. "&" document member of the same patent family
"A" document defining the general state of the art which is not considered to be of particular relevance "E" earlier document but published on or after the international filing date "L" document which may throw doubts on priority claim(s) or which is cited to establish the publication date of another citation or other special reason (as specified) "O" document referring to an oral disclosure, use, exhibition or other means "P" document published prior to the international filing date but later than the priority date claimed	"T" later document published after the international filing date or priority date and not in conflict with the application but cited to understand the principle or theory underlying the invention "X" document of particular relevance; the claimed invention cannot be considered novel or cannot be considered to involve an inventive step when the document is taken alone "Y" document of particular relevance; the claimed invention cannot be considered to involve an inventive step when the document is combined with one or more other such documents, such combination being obvious to a person skilled in the art. "&" document member of the same patent family			
Date of the actual completion of the international search 24 June 1994		Date of mailing of the international search report 13. 07. 94		
Name and mailing address of the ISA European Patent Office, P.B. 5818 Patentlaan 2 NL - 2280 HV Rijswijk Tel. (+ 31-70) 340-2040, Tx. 31 651 epo nl, Fax: (+ 31-70) 340-3016		Authorized officer Claessen, L		

INTERNATIONAL SEARCH REPORT

International Application No

PCT/EP 93/03115

C.(Continuation) DOCUMENTS CONSIDERED TO BE RELEVANT

Category	Citation of document, with indication, where appropriate, of the relevant passages	Relevant to claim No.
X	WO,A,93 21553 (DEUTSCHE AEROSPACE) 28 October 1993	1,2,6, 8-11
A	see abstract; figures ---	3,4
A	APPLIED PHYSICS LETTERS., vol.31, no.8, 15 October 1977, NEW YORK US pages 521 - 523 K.E. PETERSEN 'Micromechanical light modulator array fabricated on silicon' see the whole document ---	1,5
A	MICROELECTRONIC ENGINEERING, vol.3, 1985, AMSTERDAM NL pages 221 - 234 L. CSEPREGI 'Micromechanics: A silicon microfabrication technology' cited in the application see the whole document ---	1-15
A	PATENT ABSTRACTS OF JAPAN vol. 16, no. 272 (P-1373) 18 June 1992 & JP,A,04 070 506 (OLYMPUS OPTICAL CO LTD) see abstract ---	1,14
A	PATENT ABSTRACTS OF JAPAN vol. 12, no. 127 (E-602) 20 April 1988 & JP,A,62 254 479 (RICOH CO LTD) see abstract ---	1,6
A	PATENT ABSTRACTS OF JAPAN vol. 17, no. 328 (E-1385) 22 June 1993 & JP,A,05 037 087 (TOSHIBA CORP) see abstract ---	1,7
A	US,A,5 228 050 (LACOURSE ET AL) 13 July 1993 see abstract; figure 1 ---	1,8
A	EP,A,0 370 739 (STC PLC) 30 May 1990 cited in the application see abstract; figure 1 -----	1

INTERNATIONAL SEARCH REPORT
Information on patent family members

International Application No

PCT/EP 93/03115

Patent document cited in search report	Publication date	Patent family member(s)	Publication date
WO-A-9321553	28-10-93	DE-A- 4211898 DE-A- 4215797	28-10-93 25-11-93
US-A-5228050	13-07-93	NONE	
EP-A-0370739	30-05-90	GB-A- 2225482 JP-A- 2244784 US-A- 5115444	30-05-90 28-09-90 19-05-92