



(51) International Patent Classification:

H04L 5/00 (2006.01) H04L 29/06 (2006.01)  
H04L 27/26 (2006.01)

(21) International Application Number:

PCT/KR2019/011976

(22) International Filing Date:

17 September 2019 (17.09.2019)

(25) Filing Language:

English

(26) Publication Language:

English

(30) Priority Data:

10-2018-0111370 18 September 2018 (18.09.2018) KR

(71) Applicant: **LG ELECTRONICS INC.** [KR/KR]; 128, Yeoui-daero, Yeongdeungpo-gu, Seoul, 07336 (KR).

(72) Inventors: **BYUN, Daewook**; IP Center, LG Electronics Inc., 19, Yangjae-daero 11-gil, Seocho-gu, Seoul 06772 (KR). **XU, Jian**; IP Center, LG Electronics Inc., 19, Yangjae-daero 11-gil, Seocho-gu, Seoul 06772 (KR). **KIM,**

**Seokjung**; IP Center, LG Electronics Inc., 19, Yangjae-daero 11-gil, Seocho-gu, Seoul 06772 (KR).

(74) Agent: **ENVISION PATENT & LAW FIRM**; 8F, 16, Teheran-ro 70-gil, Gangnam-gu, Seoul 06193 (KR).

(81) Designated States (unless otherwise indicated, for every kind of national protection available): AE, AG, AL, AM, AO, AT, AU, AZ, BA, BB, BG, BH, BN, BR, BW, BY, BZ, CA, CH, CL, CN, CO, CR, CU, CZ, DE, DJ, DK, DM, DO, DZ, EC, EE, EG, ES, FI, GB, GD, GE, GH, GM, GT, HN, HR, HU, ID, IL, IN, IR, IS, JO, JP, KE, KG, KH, KN, KP, KR, KW, KZ, LA, LC, LK, LR, LS, LU, LY, MA, MD, ME, MG, MK, MN, MW, MX, MY, MZ, NA, NG, NI, NO, NZ, OM, PA, PE, PG, PH, PL, PT, QA, RO, RS, RU, RW, SA, SC, SD, SE, SG, SK, SL, SM, ST, SV, SY, TH, TJ, TM, TN, TR, TT, TZ, UA, UG, US, UZ, VC, VN, ZA, ZM, ZW.

(84) Designated States (unless otherwise indicated, for every kind of regional protection available): ARIPO (BW, GH, GM, KE, LR, LS, MW, MZ, NA, RW, SD, SL, ST, SZ, TZ, UG, ZM, ZW), Eurasian (AM, AZ, BY, KG, KZ, RU, TJ,

(54) Title: SIGNALING BETWEEN NODES FOR RESOURCE ALLOCATION

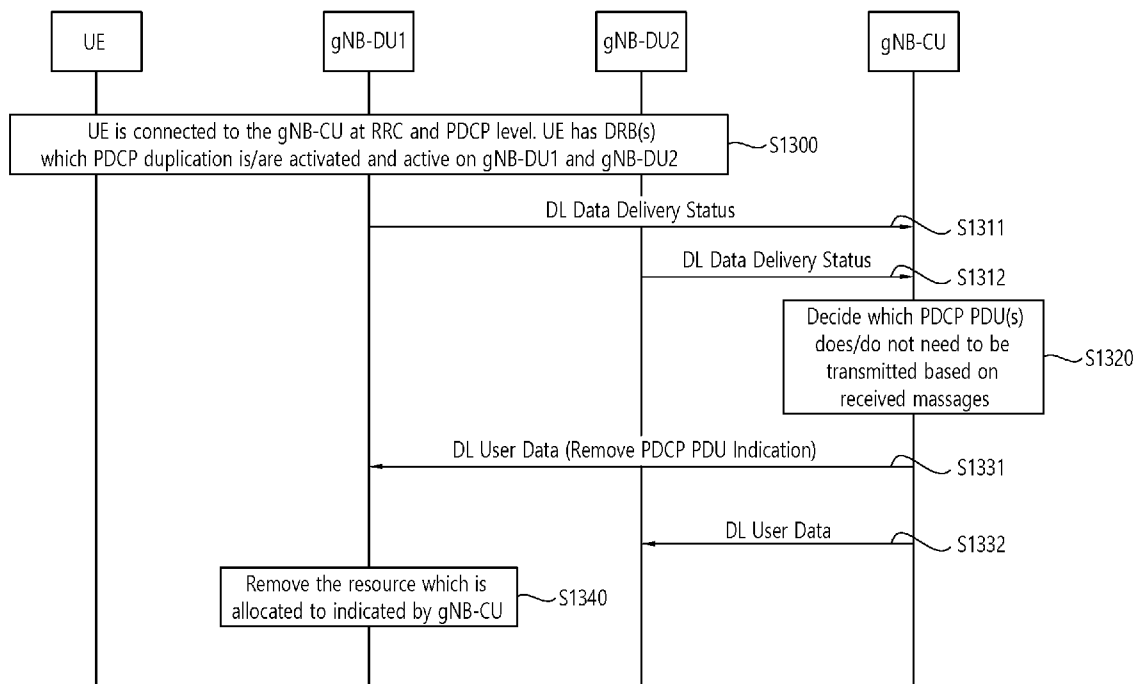

(57) Abstract: A method and apparatus for supporting signaling between nodes, e.g., gNB central unit (gNB-CU) and gNB distributed unit (gNB-DU), for efficient resource allocation is provided. The gNB-CU receives a delivery status of downlink (DL) data from a first gNB-DU and a second gNB-DU. The gNB-CU determines that a packet data convergence protocol (PDCP) protocol data unit (PDU) from the DL data does not need to be transmitted to a wireless device based on the delivery status of the DL data. The gNB-CU transmits an indication to at least one gNB-DU among the first gNB-DU and the second gNB-DU. The at least one gNB-DU has the PDCP PDU which does not need to be transmitted to the wireless device. Upon receiving the indication from the gNB-CU, the gNB-DU removes resources for transmitting the PDCP PDU based on the indication.



TM), European (AL, AT, BE, BG, CH, CY, CZ, DE, DK, EE, ES, FI, FR, GB, GR, HR, HU, IE, IS, IT, LT, LU, LV, MC, MK, MT, NL, NO, PL, PT, RO, RS, SE, SI, SK, SM, TR), OAPI (BF, BJ, CF, CG, CI, CM, GA, GN, GQ, GW, KM, ML, MR, NE, SN, TD, TG).

**Published:**

— *with international search report (Art. 21(3))*

## Description

### Title of Invention: SIGNALING BETWEEN NODES FOR RESOURCE ALLOCATION

#### Technical Field

- [1] The present disclosure relates to a signaling between nodes, e.g., gNB central unit (gNB-CU) and gNB distributed unit (gNB-DU), for efficient resource allocation.

#### Background Art

- [2] 3rd generation partnership project (3GPP) long-term evolution (LTE) is a technology for enabling high-speed packet communications. Many schemes have been proposed for the LTE objective including those that aim to reduce user and provider costs, improve service quality, and expand and improve coverage and system capacity. The 3GPP LTE requires reduced cost per bit, increased service availability, flexible use of a frequency band, a simple structure, an open interface, and adequate power consumption of a terminal as an upper-level requirement.
- [3] Work has started in international telecommunication union (ITU) and 3GPP to develop requirements and specifications for new radio (NR) systems. 3GPP has to identify and develop the technology components needed for successfully standardizing the new RAT timely satisfying both the urgent market needs, and the more long-term requirements set forth by the ITU radio communication sector (ITU-R) international mobile telecommunications (IMT)-2020 process. Further, the NR should be able to use any spectrum band ranging at least up to 100 GHz that may be made available for wireless communications even in a more distant future.
- [4] The NR targets a single technical framework addressing all usage scenarios, requirements and deployment scenarios including enhanced mobile broadband (eMBB), massive machine-type-communications (mMTC), ultra-reliable and low latency communications (URLLC), etc. The NR shall be inherently forward compatible.
- [5] Mobile carriers are providing more services in service areas which get smaller. This small service area may be specified as a small cell. However, it may be an issue to communicate travelling between these small service areas, in which all of capacity, coverage, and interference need to be considered. Accordingly, it has been proposed to serve small cells through a centralized radio access network (C-RAN). One requirement for implementing the C-RAN is a new concept called fronthaul.
- [6] In NR, it has been introduced to divide a base station (e.g. gNB) into a central unit (CU) and a distributed unit (DU) in order to solve the problem of fronthaul. The gNB-CU hosts radio resource control (RRC), packet data convergence protocol (PDCP), and optionally service data adaptation protocol (SDAP) protocols of the base station. The

gNB-DU hosts radio link control (RLC), media access control (MAC), and physical layers of the base station.

## **Disclosure of Invention**

### **Technical Problem**

- [7] In 5G NR, packet duplication (or, PDCP duplication) has been introduced. Duplication may be supported in CU-DU split. However, unnecessary resource utilization should be addressed.

### **Solution to Problem**

- [8] In an aspect, a method for a gNB central unit (CU) in a wireless communication system is provided. The gNB-CU receives a delivery status of downlink (DL) data from a first gNB distributed unit (DU) and a second gNB-DU. The gNB-CU determines that a packet data convergence protocol (PDCP) protocol data unit (PDU) from the DL data does not need to be transmitted to a wireless device based on the delivery status of the DL data. The gNB-CU transmits an indication to at least one gNB-DU among the first gNB-DU and the second gNB-DU. The at least one gNB-DU has the PDCP PDU which does not need to be transmitted to the wireless device.
- [9] In another aspect, a method for a gNB-DU in a wireless communication system is provided. The gNB-DU receives an indication indicating removal of resources for transmitting a packet data convergence protocol (PDCP) protocol data unit (PDU) from DL data which does not need to be transmitted to a wireless device from a gNB-CU, and removes the resources for transmitting the PDCP PDU based on the indication.
- [10] In another aspect, an apparatus for implementing the above mentioned methods is provided.

### **Advantageous Effects of Invention**

- [11] The present disclosure can have various advantageous effects.
- [12] For example, unnecessary radio resource allocation can be avoided in case packet data convergence protocol (PDCP) duplication is applied for adjacent gNB distributed units (gNB-DUs) within the same gNB central unit (gNB-CU).
- [13] For example, the gNB-CU can inform one gNB-DU which has PDCP protocol data units (PDUs) which has already been sent successfully at other gNB-DU.
- [14] For example, the gNB-DU which has PDCP PDUs which has already been sent successfully at other gNB-DU can remove resources to transmit the PDCP PDUs which does not need to be transmitted to the wireless device.
- [15] For example, gNB-DUs within the same gNB-CU can use radio resource efficiently.
- [16] For example, UE's experience can be enhanced (e.g., support of ultra-reliable low latency communication (URLLC)) when PDCP duplication is applied.

[17] Advantageous effects which can be obtained through specific embodiments of the present disclosure are not limited to the advantageous effects listed above. For example, there may be a variety of technical effects that a person having ordinary skill in the related art can understand and/or derive from the present disclosure. Accordingly, the specific effects of the present disclosure are not limited to those explicitly described herein, but may include various effects that may be understood or derived from the technical features of the present disclosure.

### **Brief Description of Drawings**

[18] FIG. 1 shows examples of 5G usage scenarios to which the technical features of the present disclosure can be applied.

[19] FIG. 2 shows an example of a wireless communication system to which the technical features of the present disclosure can be applied.

[20] FIG. 3 shows an example of a wireless communication system to which the technical features of the present disclosure can be applied.

[21] FIG. 4 shows another example of a wireless communication system to which the technical features of the present disclosure can be applied.

[22] FIG. 5 shows a block diagram of a user plane protocol stack to which the technical features of the present disclosure can be applied.

[23] FIG. 6 shows a block diagram of a control plane protocol stack to which the technical features of the present disclosure can be applied.

[24] FIG. 7 shows an example of the overall architecture of an NG-RAN to which technical features of the present disclosure can be applied.

[25] FIG. 8 shows an interface protocol structure for F1-C to which technical features of the present disclosure can be applied.

[26] FIG. 9 shows a data flow example to which technical features of the present disclosure can be applied.

[27] FIG. 10 shows an example of Assistance Information Data frame to which the technical features of the present disclosure can be applied.

[28] FIG. 11 shows an example of a method for gNB-CU according to the embodiment of the present disclosure.

[29] FIG. 12 shows an example of a method for gNB-DU according to the embodiment of the present disclosure.

[30] FIG. 13 shows an example of a procedure for inter-gNB-DU PDCP duplication according to the embodiment of the present disclosure.

[31] FIG. 14 shows an example of an AI device to which the technical features of the present disclosure can be applied.

[32] FIG. 15 shows an example of an AI system to which the technical features of the

present disclosure can be applied.

### **Mode for the Invention**

- [33] The technical features described below may be used by a communication standard by the 3rd generation partnership project (3GPP) standardization organization, a communication standard by the institute of electrical and electronics engineers (IEEE), etc. For example, the communication standards by the 3GPP standardization organization include long-term evolution (LTE) and/or evolution of LTE systems. The evolution of LTE systems includes LTE-advanced (LTE-A), LTE-A Pro, and/or 5G new radio (NR). The communication standard by the IEEE standardization organization includes a wireless local area network (WLAN) system such as IEEE 802.11a/b/g/n/ac/ax. The above system uses various multiple access technologies such as orthogonal frequency division multiple access (OFDMA) and/or single carrier frequency division multiple access (SC-FDMA) for downlink (DL) and/or uplink (UL). For example, only OFDMA may be used for DL and only SC-FDMA may be used for UL. Alternatively, OFDMA and SC-FDMA may be used for DL and/or UL.
- [34] In the present disclosure, the term "/" and "," should be interpreted to indicate "and/or." For instance, the expression "A/B" may mean "A and/or B." Further, "A, B" may mean "A and/or B." Further, "A/B/C" may mean "at least one of A, B, and/or C." Also, "A, B, C" may mean "at least one of A, B, and/or C."
- [35] Further, in the present disclosure, the term "or" should be interpreted to indicate "and/or." For instance, the expression "A or B" may comprise 1) only A, 2) only B, and/or 3) both A and B. In other words, the term "or" in the present disclosure should be interpreted to indicate "additionally or alternatively."
- [36] The following drawings are created to explain specific embodiments of the present disclosure. The names of the specific devices or the names of the specific signals/messages/fields shown in the drawings are provided by way of example, and thus the technical features of the present disclosure are not limited to the specific names used in the following drawings.
- [37] FIG. 1 shows examples of 5G usage scenarios to which the technical features of the present disclosure can be applied.
- [38] The 5G usage scenarios shown in FIG. 1 are only exemplary, and the technical features of the present disclosure can be applied to other 5G usage scenarios which are not shown in FIG. 1.
- [39] Referring to FIG. 1, the three main requirements areas of 5G include (1) enhanced mobile broadband (eMBB) domain, (2) massive machine type communication (mMTC) area, and (3) ultra-reliable and low latency communications (URLLC) area. Some use cases may require multiple areas for optimization and, other use cases may

only focus on only one key performance indicator (KPI). 5G is to support these various use cases in a flexible and reliable way.

[40] eMBB focuses on across-the-board enhancements to the data rate, latency, user density, capacity and coverage of mobile broadband access. The eMBB aims ~10 Gbps of throughput. eMBB far surpasses basic mobile Internet access and covers rich interactive work and media and entertainment applications in cloud and/or augmented reality. Data is one of the key drivers of 5G and may not be able to see dedicated voice services for the first time in the 5G era. In 5G, the voice is expected to be processed as an application simply using the data connection provided by the communication system. The main reason for the increased volume of traffic is an increase in the size of the content and an increase in the number of applications requiring high data rates. Streaming services (audio and video), interactive video and mobile Internet connectivity will become more common as more devices connect to the Internet. Many of these applications require always-on connectivity to push real-time information and notifications to the user. Cloud storage and applications are growing rapidly in mobile communication platforms, which can be applied to both work and entertainment. Cloud storage is a special use case that drives growth of uplink data rate. 5G is also used for remote tasks on the cloud and requires much lower end-to-end delay to maintain a good user experience when the tactile interface is used. In entertainment, for example, cloud games and video streaming are another key factor that increases the demand for mobile broadband capabilities. Entertainment is essential in smartphones and tablets anywhere, including high mobility environments such as trains, cars and airplanes. Another use case is augmented reality and information retrieval for entertainment. Here, augmented reality requires very low latency and instantaneous data amount.

[41] mMTC is designed to enable communication between devices that are low-cost, massive in number and battery-driven, intended to support applications such as smart metering, logistics, and field and body sensors. mMTC aims ~10 years on battery and/or ~1 million devices/km<sup>2</sup>. mMTC allows seamless integration of embedded sensors in all areas and is one of the most widely used 5G applications. Potentially by 2020, internet-of-things (IoT) devices are expected to reach 20.4 billion. Industrial IoT is one of the areas where 5G plays a key role in enabling smart cities, asset tracking, smart utilities, agriculture and security infrastructures.

[42] URLLC will make it possible for devices and machines to communicate with ultra-reliability, very low latency and high availability, making it ideal for vehicular communication, industrial control, factory automation, remote surgery, smart grids and public safety applications. URLLC aims ~1ms of latency. URLLC includes new services that will change the industry through links with ultra-reliability / low latency, such as

remote control of key infrastructure and self-driving vehicles. The level of reliability and latency is essential for smart grid control, industrial automation, robotics, drones control and coordination.

[43] Next, a plurality of use cases included in the triangle of FIG. 1 will be described in more detail.

[44] 5G can complement fiber-to-the-home (FTTH) and cable-based broadband (or DOCSIS) as a means of delivering streams rated from hundreds of megabits per second to gigabits per second. This high speed can be required to deliver TVs with resolutions of 4K or more (6K, 8K and above) as well as virtual reality (VR) and augmented reality (AR). VR and AR applications include mostly immersive sporting events. Certain applications may require special network settings. For example, in the case of a VR game, a game company may need to integrate a core server with an edge network server of a network operator to minimize delay.

[45] Automotive is expected to become an important new driver for 5G, with many use cases for mobile communications to vehicles. For example, entertainment for passengers demands high capacity and high mobile broadband at the same time. This is because future users will continue to expect high-quality connections regardless of their location and speed. Another use case in the automotive sector is an augmented reality dashboard. The driver can identify an object in the dark on top of what is being viewed through the front window through the augmented reality dashboard. The augmented reality dashboard displays information that will inform the driver about the object's distance and movement. In the future, the wireless module enables communication between vehicles, information exchange between the vehicle and the supporting infrastructure, and information exchange between the vehicle and other connected devices (e.g. devices accompanied by a pedestrian). The safety system allows the driver to guide the alternative course of action so that he can drive more safely, thereby reducing the risk of accidents. The next step will be a remotely controlled vehicle or self-driving vehicle. This requires a very reliable and very fast communication between different self-driving vehicles and between vehicles and infrastructure. In the future, a self-driving vehicle will perform all driving activities, and the driver will focus only on traffic that the vehicle itself cannot identify. The technical requirements of self-driving vehicles require ultra-low latency and high-speed reliability to increase traffic safety to a level not achievable by humans.

[46] Smart cities and smart homes, which are referred to as smart societies, will be embedded in high density wireless sensor networks. The distributed network of intelligent sensors will identify conditions for cost and energy-efficient maintenance of a city or house. A similar setting can be performed for each home. Temperature sensors, windows and heating controllers, burglar alarms and appliances are all wirelessly

connected. Many of these sensors typically require low data rate, low power and low cost. However, for example, real-time high-definition (HD) video may be required for certain types of devices for monitoring.

[47] The consumption and distribution of energy, including heat or gas, is highly dispersed, requiring automated control of distributed sensor networks. The smart grid interconnects these sensors using digital information and communication technologies to collect and act on information. This information can include supplier and consumer behavior, allowing the smart grid to improve the distribution of fuel, such as electricity, in terms of efficiency, reliability, economy, production sustainability, and automated methods. The smart grid can be viewed as another sensor network with low latency.

[48] The health sector has many applications that can benefit from mobile communications. Communication systems can support telemedicine to provide clinical care in remote locations. This can help to reduce barriers to distance and improve access to health services that are not continuously available in distant rural areas. It is also used to save lives in critical care and emergency situations. Mobile communication based wireless sensor networks can provide remote monitoring and sensors for parameters such as heart rate and blood pressure.

[49] Wireless and mobile communications are becoming increasingly important in industrial applications. Wiring costs are high for installation and maintenance. Thus, the possibility of replacing a cable with a wireless link that can be reconfigured is an attractive opportunity in many industries. However, achieving this requires that wireless connections operate with similar delay, reliability, and capacity as cables and that their management is simplified. Low latency and very low error probabilities are new requirements that need to be connected to 5G.

[50] Logistics and freight tracking are important use cases of mobile communications that enable tracking of inventory and packages anywhere using location based information systems. Use cases of logistics and freight tracking typically require low data rates, but require a large range and reliable location information.

[51] FIG. 2 shows an example of a wireless communication system to which the technical features of the present disclosure can be applied.

[52] Referring to FIG. 2, the wireless communication system may include a first device 210 and a second device 220.

[53] The first device 210 includes a base station, a network node, a transmitting UE, a receiving UE, a wireless device, a wireless communication device, a vehicle, a vehicle equipped with an autonomous driving function, a connected car, a drone, an unmanned aerial vehicle (UAV), an artificial intelligence (AI) module, a robot, an AR device, a VR device, a mixed reality (MR) device, a hologram device, a public safety device, an

MTC device, an IoT device, a medical device, a fin-tech device (or, a financial device), a security device, a climate/environmental device, a device related to 5G services, or a device related to the fourth industrial revolution.

[54] The second device 220 includes a base station, a network node, a transmitting UE, a receiving UE, a wireless device, a wireless communication device, a vehicle, a vehicle equipped with an autonomous driving function, a connected car, a drone, a UAV, an AI module, a robot, an AR device, a VR device, an MR device, a hologram device, a public safety device, an MTC device, an IoT device, a medical device, a fin-tech device (or, a financial device), a security device, a climate/environmental device, a device related to 5G services, or a device related to the fourth industrial revolution.

[55] For example, the UE may include a mobile phone, a smart phone, a laptop computer, a digital broadcasting terminal, a personal digital assistant (PDA), a portable multimedia player (PMP), a navigation device, a slate personal computer (PC), a tablet PC, an ultrabook, a wearable device (e.g. a smartwatch, a smart glass, a head mounted display (HMD)). For example, the HMD may be a display device worn on the head. For example, the HMD may be used to implement AR, VR and/or MR.

[56] For example, the drone may be a flying object that is flying by a radio control signal without a person boarding it. For example, the VR device may include a device that implements an object or background in the virtual world. For example, the AR device may include a device that implements connection of an object and/or a background of a virtual world to an object and/or a background of the real world. For example, the MR device may include a device that implements fusion of an object and/or a background of a virtual world to an object and/or a background of the real world. For example, the hologram device may include a device that implements a 360-degree stereoscopic image by recording and playing stereoscopic information by utilizing a phenomenon of interference of light generated by the two laser lights meeting with each other, called holography. For example, the public safety device may include a video relay device or a video device that can be worn by the user's body. For example, the MTC device and the IoT device may be a device that do not require direct human intervention or manipulation. For example, the MTC device and the IoT device may include a smart meter, a vending machine, a thermometer, a smart bulb, a door lock and/or various sensors. For example, the medical device may be a device used for the purpose of diagnosing, treating, alleviating, handling, or preventing a disease. For example, the medical device may be a device used for the purpose of diagnosing, treating, alleviating, or correcting an injury or disorder. For example, the medical device may be a device used for the purpose of inspecting, replacing or modifying a structure or function. For example, the medical device may be a device used for the purpose of controlling pregnancy. For example, the medical device may include a treatment

device, a surgical device, an (in vitro) diagnostic device, a hearing aid and/or a procedural device, etc. For example, a security device may be a device installed to prevent the risk that may occur and to maintain safety. For example, the security device may include a camera, a closed-circuit TV (CCTV), a recorder, or a black box. For example, the fin-tech device may be a device capable of providing financial services such as mobile payment. For example, the fin-tech device may include a payment device or a point of sales (POS). For example, the climate/environmental device may include a device for monitoring or predicting the climate/environment.

[57] The first device 210 may include at least one or more processors, such as a processor 211, at least one memory, such as a memory 212, and at least one transceiver, such as a transceiver 213. The processor 211 may perform the functions, procedures, and/or methods of the present disclosure described below. The processor 211 may perform one or more protocols. For example, the processor 211 may perform one or more layers of the air interface protocol. The memory 212 is connected to the processor 211 and may store various types of information and/or instructions. The transceiver 213 is connected to the processor 211 and may be controlled to transmit and receive wireless signals.

[58] The second device 220 may include at least one or more processors, such as a processor 221, at least one memory, such as a memory 222, and at least one transceiver, such as a transceiver 223. The processor 221 may perform the functions, procedures, and/or methods of the present disclosure described below. The processor 221 may perform one or more protocols. For example, the processor 221 may perform one or more layers of the air interface protocol. The memory 222 is connected to the processor 221 and may store various types of information and/or instructions. The transceiver 223 is connected to the processor 221 and may be controlled to transmit and receive wireless signals.

[59] The memory 212, 222 may be connected internally or externally to the processor 211, 221, or may be connected to other processors via a variety of technologies such as wired or wireless connections.

[60] The first device 210 and/or the second device 220 may have more than one antenna. For example, antenna 214 and/or antenna 224 may be configured to transmit and receive wireless signals.

[61] FIG. 3 shows an example of a wireless communication system to which the technical features of the present disclosure can be applied.

[62] Specifically, FIG. 3 shows a system architecture based on an evolved-UMTS terrestrial radio access network (E-UTRAN). The aforementioned LTE is a part of an evolved-UTMS (e-UMTS) using the E-UTRAN.

[63] Referring to FIG. 3, the wireless communication system includes one or more user

equipment (UE) 310, an E-UTRAN and an evolved packet core (EPC). The UE 310 refers to a communication equipment carried by a user. The UE 310 may be fixed or mobile. The UE 310 may be referred to as another terminology, such as a mobile station (MS), a user terminal (UT), a subscriber station (SS), a wireless device, etc.

[64] The E-UTRAN consists of one or more evolved NodeB (eNB) 320. The eNB 320 provides the E-UTRA user plane and control plane protocol terminations towards the UE 10. The eNB 320 is generally a fixed station that communicates with the UE 310. The eNB 320 hosts the functions, such as inter-cell radio resource management (RRM), radio bearer (RB) control, connection mobility control, radio admission control, measurement configuration/provision, dynamic resource allocation (scheduler), etc. The eNB 320 may be referred to as another terminology, such as a base station (BS), a base transceiver system (BTS), an access point (AP), etc.

[65] A downlink (DL) denotes communication from the eNB 320 to the UE 310. An uplink (UL) denotes communication from the UE 310 to the eNB 320. A sidelink (SL) denotes communication between the UEs 310. In the DL, a transmitter may be a part of the eNB 320, and a receiver may be a part of the UE 310. In the UL, the transmitter may be a part of the UE 310, and the receiver may be a part of the eNB 320. In the SL, the transmitter and receiver may be a part of the UE 310.

[66] The EPC includes a mobility management entity (MME), a serving gateway (S-GW) and a packet data network (PDN) gateway (P-GW). The MME hosts the functions, such as non-access stratum (NAS) security, idle state mobility handling, evolved packet system (EPS) bearer control, etc. The S-GW hosts the functions, such as mobility anchoring, etc. The S-GW is a gateway having an E-UTRAN as an endpoint. For convenience, MME/S-GW 330 will be referred to herein simply as a "gateway," but it is understood that this entity includes both the MME and S-GW. The P-GW hosts the functions, such as UE Internet protocol (IP) address allocation, packet filtering, etc. The P-GW is a gateway having a PDN as an endpoint. The P-GW is connected to an external network.

[67] The UE 310 is connected to the eNB 320 by means of the Uu interface. The UEs 310 are interconnected with each other by means of the PC5 interface. The eNBs 320 are interconnected with each other by means of the X2 interface. The eNBs 320 are also connected by means of the S1 interface to the EPC, more specifically to the MME by means of the S1-MME interface and to the S-GW by means of the S1-U interface. The S1 interface supports a many-to-many relation between MMEs / S-GWs and eNBs.

[68] FIG. 4 shows another example of a wireless communication system to which the technical features of the present disclosure can be applied.

[69] Specifically, FIG. 4 shows a system architecture based on a 5G NR. The entity used in the 5G NR (hereinafter, simply referred to as "NR") may absorb some or all of the

functions of the entities introduced in FIG. 3 (e.g. eNB, MME, S-GW). The entity used in the NR may be identified by the name "NG" for distinction from the LTE/LTE-A.

[70] Referring to FIG. 4, the wireless communication system includes one or more UE 410, a next-generation RAN (NG-RAN) and a 5th generation core network (5GC). The NG-RAN consists of at least one NG-RAN node. The NG-RAN node is an entity corresponding to the eNB 320 shown in FIG. 3. The NG-RAN node consists of at least one gNB 421 and/or at least one ng-eNB 422. The gNB 421 provides NR user plane and control plane protocol terminations towards the UE 410. The ng-eNB 422 provides E-UTRA user plane and control plane protocol terminations towards the UE 410.

[71] The 5GC includes an access and mobility management function (AMF), a user plane function (UPF) and a session management function (SMF). The AMF hosts the functions, such as NAS security, idle state mobility handling, etc. The AMF is an entity including the functions of the conventional MME. The UPF hosts the functions, such as mobility anchoring, protocol data unit (PDU) handling. The UPF an entity including the functions of the conventional S-GW. The SMF hosts the functions, such as UE IP address allocation, PDU session control.

[72] The gNBs 421 and ng-eNBs 422 are interconnected with each other by means of the Xn interface. The gNBs 421 and ng-eNBs 422 are also connected by means of the NG interfaces to the 5GC, more specifically to the AMF by means of the NG-C interface and to the UPF by means of the NG-U interface.

[73] A protocol structure between network entities described above is described. On the system of FIG. 3 and/or FIG. 4, layers of a radio interface protocol between the UE and the network (e.g. NG-RAN and/or E-UTRAN) may be classified into a first layer (L1), a second layer (L2), and a third layer (L3) based on the lower three layers of the open system interconnection (OSI) model that is well-known in the communication system.

[74] FIG. 5 shows a block diagram of a user plane protocol stack to which the technical features of the present disclosure can be applied. FIG. 6 shows a block diagram of a control plane protocol stack to which the technical features of the present disclosure can be applied.

[75] The user/control plane protocol stacks shown in FIG. 5 and FIG. 6 are used in NR. However, user/control plane protocol stacks shown in FIG. 5 and FIG. 6 may be used in LTE/LTE-A without loss of generality, by replacing gNB/AMF with eNB/MME.

[76] Referring to FIG. 5 and FIG. 6, a physical (PHY) layer belonging to L1. The PHY layer offers information transfer services to media access control (MAC) sublayer and higher layers. The PHY layer offers to the MAC sublayer transport channels. Data between the MAC sublayer and the PHY layer is transferred via the transport channels. Between different PHY layers, i.e., between a PHY layer of a transmission side and a

PHY layer of a reception side, data is transferred via the physical channels.

- [77] The MAC sublayer belongs to L2. The main services and functions of the MAC sublayer include mapping between logical channels and transport channels, multiplexing/de-multiplexing of MAC service data units (SDUs) belonging to one or different logical channels into/from transport blocks (TB) delivered to/from the physical layer on transport channels, scheduling information reporting, error correction through hybrid automatic repeat request (HARQ), priority handling between UEs by means of dynamic scheduling, priority handling between logical channels of one UE by means of logical channel prioritization (LCP), etc. The MAC sublayer offers to the radio link control (RLC) sublayer logical channels.
- [78] The RLC sublayer belong to L2. The RLC sublayer supports three transmission modes, i.e. transparent mode (TM), unacknowledged mode (UM), and acknowledged mode (AM), in order to guarantee various quality of services (QoS) required by radio bearers. The main services and functions of the RLC sublayer depend on the transmission mode. For example, the RLC sublayer provides transfer of upper layer PDUs for all three modes, but provides error correction through ARQ for AM only. In LTE/LTE-A, the RLC sublayer provides concatenation, segmentation and reassembly of RLC SDUs (only for UM and AM data transfer) and re-segmentation of RLC data PDUs (only for AM data transfer). In NR, the RLC sublayer provides segmentation (only for AM and UM) and re-segmentation (only for AM) of RLC SDUs and re-assembly of SDU (only for AM and UM). That is, the NR does not support concatenation of RLC SDUs. The RLC sublayer offers to the packet data convergence protocol (PDCP) sublayer RLC channels.
- [79] The PDCP sublayer belong to L2. The main services and functions of the PDCP sublayer for the user plane include header compression and decompression, transfer of user data, duplicate detection, PDCP PDU routing, retransmission of PDCP SDUs, ciphering and deciphering, etc. The main services and functions of the PDCP sublayer for the control plane include ciphering and integrity protection, transfer of control plane data, etc.
- [80] The service data adaptation protocol (SDAP) sublayer belong to L2. The SDAP sublayer is only defined in the user plane. The SDAP sublayer is only defined for NR. The main services and functions of SDAP include, mapping between a QoS flow and a data radio bearer (DRB), and marking QoS flow ID (QFI) in both DL and UL packets. The SDAP sublayer offers to 5GC QoS flows.
- [81] A radio resource control (RRC) layer belongs to L3. The RRC layer is only defined in the control plane. The RRC layer controls radio resources between the UE and the network. To this end, the RRC layer exchanges RRC messages between the UE and the BS. The main services and functions of the RRC layer include broadcast of system in-

formation related to AS and NAS, paging, establishment, maintenance and release of an RRC connection between the UE and the network, security functions including key management, establishment, configuration, maintenance and release of radio bearers, mobility functions, QoS management functions, UE measurement reporting and control of the reporting, NAS message transfer to/from NAS from/to UE.

[82] In other words, the RRC layer controls logical channels, transport channels, and physical channels in relation to the configuration, reconfiguration, and release of radio bearers. A radio bearer refers to a logical path provided by L1 (PHY layer) and L2 (MAC/RLC/PDCP/SDAP sublayer) for data transmission between a UE and a network. Setting the radio bearer means defining the characteristics of the radio protocol layer and the channel for providing a specific service, and setting each specific parameter and operation method. Radio bearer may be divided into signaling RB (SRB) and data RB (DRB). The SRB is used as a path for transmitting RRC messages in the control plane, and the DRB is used as a path for transmitting user data in the user plane.

[83] An RRC state indicates whether an RRC layer of the UE is logically connected to an RRC layer of the E-UTRAN. In LTE/LTE-A, when the RRC connection is established between the RRC layer of the UE and the RRC layer of the E-UTRAN, the UE is in the RRC connected state (RRC\_CONNECTED). Otherwise, the UE is in the RRC idle state (RRC\_IDLE). In NR, the RRC inactive state (RRC\_INACTIVE) is additionally introduced. RRC\_INACTIVE may be used for various purposes. For example, the massive machine type communications (MMTC) UEs can be efficiently managed in RRC\_INACTIVE. When a specific condition is satisfied, transition is made from one of the above three states to the other.

[84] A predetermined operation may be performed according to the RRC state. In RRC\_IDLE, public land mobile network (PLMN) selection, broadcast of system information (SI), cell re-selection mobility, core network (CN) paging and discontinuous reception (DRX) configured by NAS may be performed. The UE shall have been allocated an identifier (ID) which uniquely identifies the UE in a tracking area. No RRC context stored in the BS.

[85] In RRC\_CONNECTED, the UE has an RRC connection with the network (i.e. E-UTRAN/NG-RAN). Network-CN connection (both C/U-planes) is also established for UE. The UE AS context is stored in the network and the UE. The RAN knows the cell which the UE belongs to. The network can transmit and/or receive data to/from UE. Network controlled mobility including measurement is also performed.

[86] Most of operations performed in RRC\_IDLE may be performed in RRC\_INACTIVE. But, instead of CN paging in RRC\_IDLE, RAN paging is performed in RRC\_INACTIVE. In other words, in RRC\_IDLE, paging for mobile

terminated (MT) data is initiated by core network and paging area is managed by core network. In RRC\_INACTIVE, paging is initiated by NG-RAN, and RAN-based notification area (RNA) is managed by NG-RAN. Further, instead of DRX for CN paging configured by NAS in RRC\_IDLE, DRX for RAN paging is configured by NG-RAN in RRC\_INACTIVE. Meanwhile, in RRC\_INACTIVE, 5GC-NG-RAN connection (both C/U-planes) is established for UE, and the UE AS context is stored in NG-RAN and the UE. NG-RAN knows the RNA which the UE belongs to.

[87] NAS layer is located at the top of the RRC layer. The NAS control protocol performs the functions, such as authentication, mobility management, security control.

[88] Split of gNB central unit (gNB-CU) and gNB distributed unit (gNB-DU) is described. Section 6 of 3GPP TS 38.401 V15.2.0 (2018-06) and Sections 5.2 and 7.1 of 3GPP TS 38.470 V15.2.0 (2018-06) may be referred.

[89] FIG. 7 shows an example of the overall architecture of an NG-RAN to which technical features of the present disclosure can be applied.

[90] Referring to FIG. 7, a gNB may include a gNB-CU (hereinafter, gNB-CU may be simply referred to as CU) and at least one gNB-DU (hereinafter, gNB-DU may be simply referred to as DU).

[91] The gNB-CU is a logical node hosting RRC, SDAP and PDCP protocols of the gNB or an RRC and PDCP protocols of the en-gNB. The gNB-CU controls the operation of the at least one gNB-DU.

[92] The gNB-DU is a logical node hosting RLC, MAC, and physical layers of the gNB or the en-gNB. The operation of the gNB-DU is partly controlled by the gNB-CU. One gNB-DU supports one or multiple cells. One cell is supported by only one gNB-DU.

[93] The gNB-CU and gNB-DU are connected via an F1 interface. The gNB-CU terminates the F1 interface connected to the gNB-DU. The gNB-DU terminates the F1 interface connected to the gNB-CU. One gNB-DU is connected to only one gNB-CU. However, the gNB-DU may be connected to multiple gNB-CUs by appropriate implementation. The F1 interface is a logical interface. For NG-RAN, the NG and Xn-C interfaces for a gNB consisting of a gNB-CU and gNB-DUs, terminate in the gNB-CU. For E-UTRAN-NR dual connectivity (EN-DC), the S1-U and X2-C interfaces for a gNB consisting of a gNB-CU and gNB-DUs, terminate in the gNB-CU. The gNB-CU and connected gNB-DUs are only visible to other gNBs and the 5GC as a gNB.

[94] The node hosting user plane part of NR PDCP (e.g., gNB-CU, gNB-CU-UP, and for EN-DC, MeNB or SgNB depending on the bearer split) shall perform user inactivity monitoring and further informs its inactivity or (re)activation to the node having C-plane connection towards the core network (e.g., over E1, X2). The node hosting NR RLC (e.g., gNB-DU) may perform user inactivity monitoring and further inform its inactivity or (re)activation to the node hosting control plane, e.g., gNB-CU or gNB-

CU-CP.

- [95] UL PDCP configuration (i.e., how the UE uses the UL at the assisting node) is indicated via X2-C (for EN-DC), Xn-C (for NG-RAN) and F1-C. Radio Link outage/resume for DL and/or UL is indicated via X2-U (for EN-DC), Xn-U (for NG-RAN) and F1-U.
- [96] The NG-RAN is layered into a radio network layer (RNL) and a transport network layer (TNL).
- [97] The NG-RAN architecture, i.e., the NG-RAN logical nodes and interfaces between them, is defined as part of the RNL.
- [98] Functions of the F1 interface includes F1 control (F1-C) functions as follows.
- [99] (1) F1 interface management function
- [100] The error indication function is used by the gNB-DU or gNB-CU to indicate to the gNB-CU or gNB-DU that an error has occurred.
- [101] The reset function is used to initialize the peer entity after node setup and after a failure event occurred. This procedure can be used by both the gNB-DU and the gNB-CU.
- [102] The F1 setup function allows to exchange application level data needed for the gNB-DU and gNB-CU to interoperate correctly on the F1 interface. The F1 setup is initiated by the gNB-DU.
- [103] The gNB-CU configuration update and gNB-DU configuration update functions allow to update application level configuration data needed between gNB-CU and gNB-DU to interoperate correctly over the F1 interface, and may activate or deactivate cells.
- [104] The F1 setup and gNB-DU configuration Update functions allow to inform the single network slice selection assistance information (S-NSSAI) supported by the gNB-DU.
- [105] The F1 resource coordination function is used to transfer information about frequency resource sharing between gNB-CU and gNB-DU.
- [106] (2) System Information management function
- [107] Scheduling of system broadcast information is carried out in the gNB-DU. The gNB-DU is responsible for transmitting the system information according to the scheduling parameters available.
- [108] The gNB-DU is responsible for the encoding of NR master information block (MIB). In case broadcast of system information block type-1 (SIB1) and other SI messages is needed, the gNB-DU is responsible for the encoding of SIB1 and the gNB-CU is responsible for the encoding of other SI messages.
- [109] (3) F1 UE context management function
- [110] The F1 UE context management function supports the establishment and modification of the necessary overall UE context.

- [111] The establishment of the F1 UE context is initiated by the gNB-CU and accepted or rejected by the gNB-DU based on admission control criteria (e.g., resource not available).
- [112] The modification of the F1 UE context can be initiated by either gNB-CU or gNB-DU. The receiving node can accept or reject the modification. The F1 UE context management function also supports the release of the context previously established in the gNB-DU. The release of the context is triggered by the gNB-CU either directly or following a request received from the gNB-DU. The gNB-CU request the gNB-DU to release the UE Context when the UE enters RRC\_IDLE or RRC\_INACTIVE.
- [113] This function can be also used to manage DRBs and SRBs, i.e., establishing, modifying and releasing DRB and SRB resources. The establishment and modification of DRB resources are triggered by the gNB-CU and accepted/rejected by the gNB-DU based on resource reservation information and QoS information to be provided to the gNB-DU. For each DRB to be setup or modified, the S-NSSAI may be provided by gNB-CU to the gNB-DU in the UE context setup procedure and the UE context modification procedure.
- [114] The mapping between QoS flows and radio bearers is performed by gNB-CU and the granularity of bearer related management over F1 is radio bearer level. To support packet duplication for intra-gNB-DU carrier aggregation (CA), one data radio bearer should be configured with two GPRS tunneling protocol (GTP)-U tunnels between gNB-CU and a gNB-DU.
- [115] With this function, gNB-CU requests the gNB-DU to setup or change of the special cell (SpCell) for the UE, and the gNB-DU either accepts or rejects the request with appropriate cause value.
- [116] With this function, the gNB-CU requests the setup of the secondary cell(s) (SCell(s)) at the gNB-DU side, and the gNB-DU accepts all, some or none of the SCell(s) and replies to the gNB-CU. The gNB-CU requests the removal of the SCell(s) for the UE.
- [117] (4) RRC message transfer function
- [118] This function allows to transfer RRC messages between gNB-CU and gNB-DU. RRC messages are transferred over F1-C. The gNB-CU is responsible for the encoding of the dedicated RRC message with assistance information provided by gNB-DU.
- [119] (5) Paging function
- [120] The gNB-DU is responsible for transmitting the paging information according to the scheduling parameters provided.
- [121] The gNB-CU provides paging information to enable the gNB-DU to calculate the exact paging occasion (PO) and paging frame (PF). The gNB-CU determines the paging attempt (PA). The gNB-DU consolidates all the paging records for a particular PO, PF and PA, and encodes the final RRC message and broadcasts the paging

message on the respective PO, PF in the PA.

[122] (6) Warning messages information transfer function

[123] This function allows to cooperate with the warning message transmission procedures over NG interface. The gNB-CU is responsible for encoding the warning related SI message and sending it together with other warning related information for the gNB-DU to broadcast over the radio interface.

[124] FIG. 8 shows an interface protocol structure for F1-C to which technical features of the present disclosure can be applied.

[125] TNL is based on Internet protocol (IP) transport, comprising a stream control transmission protocol (SCTP) layer on top of the IP layer. An application layer signaling protocol is referred to as an F1 application protocol (E1AP).

[126] FIG. 9 shows a data flow example to which technical features of the present disclosure can be applied.

[127] Referring to FIG. 9, a transport block is generated by MAC by concatenating two RLC PDUs from  $RB_x$  and one RLC PDU from  $RB_y$ . The two RLC PDUs from  $RB_x$  each corresponds to one IP packet ( $n$  and  $n+1$ ) while the RLC PDU from  $RB_y$  is a segment of an IP packet ( $m$ ). That is, IP packet and PDCP PDU can be segmented into multiple RLC PDUs. H depicts the headers and subheaders.

[128] Packet duplication (or, PDCP duplication) is described. Section 16.1.3 of 3GPP TS 38.300 V15.2.0 (2018-06), Section 5.4.3 and 5.5.2.3 of 3GPP TS 38.425 V15.2.0 (2018-06) and Section 9.2.2.2 and 9.2.2.8 of 3GPP TS 38.473 V15.2.1 (2018-07) can be referred.

[129] In 5G NR, packet duplication (or, PDCP duplication) has been introduced. When duplication is configured for a radio bearer by RRC, a secondary RLC entity and a secondary logical channel are added to the radio bearer to handle the duplicated PDCP PDUs. Duplication at PDCP therefore consists in submitting the same PDCP PDUs twice: once to the primary RLC entity and a second time to the secondary RLC entity. With two independent transmission paths, packet duplication therefore increases reliability and reduces latency and is especially beneficial for URLLC services. PDCP control PDUs are not duplicated and always submitted to the primary RLC entity.

[130] When duplication is activated, the original PDCP PDU and the corresponding duplicate shall not be transmitted on the same carrier. The two different logical channels can either belong to the same MAC entity (CA) or to different ones (DC). In the former case, logical channel mapping restrictions are used in MAC to ensure that the logical channel carrying the original PDCP PDUs and logical channel carrying the corresponding duplicates are not sent on the same carrier.

[131] When an RLC entity acknowledges the transmission of a PDCP PDU, the PDCP entity shall indicate to the other RLC entity to discard it. And when the secondary RLC

entity reaches the maximum number of retransmissions for a PDCP PDU, the UE informs the gNB but does not trigger radio link failure (RLF).

- [132] When configuring duplication for a DRB, RRC also sets the initial state (either activated or deactivated). After the configuration, the state can then be dynamically controlled by means of a MAC control element and in DC, the UE applies the MAC CE commands regardless of their origin (master cell group (MCG) or secondary cell group (SCG)). When duplication is deactivated for a DRB, the secondary RLC entity is not re-established, the HARQ buffers are not flushed but the corresponding logical channel mapping restrictions - if any - are lifted, and the transmitting PDCP entity should indicate to the secondary RLC entity to discard all duplicated PDCP PDUs.
- [133] When duplication is configured for an SRB, the state is always active and cannot be dynamically controlled.
- [134] When activating duplication for a DRB, NG-RAN should ensure that at least one serving cell is activated for each logical channel of the DRB. And when the deactivation of SCells leaves no serving cells activated for a logical channel of the DRB, NG-RAN should ensure that duplication is also deactivated.
- [135] In order to support duplication for DRB, assistance information can be transferred. The purpose of the transfer of assistance information procedure is to provide assistance information to the node hosting the NR PDCP. Such information may be taken into consideration by the node hosting the NR PDCP for UP management and optimization procedures.
- [136] An NR user plane instance making use of the transfer of assistance information procedure is associated to a single data bearer only.
- [137] The transfer of assistance information procedure may be invoked if the corresponding node decides to send the radio quality assistance Information and/or the PDCP duplication activation suggestion to the node hosting the NR PDCP for that particular data bearer.
- [138] FIG. 10 shows an example of Assistance Information Data frame to which the technical features of the present disclosure can be applied.
- [139] This frame format is defined to allow the node hosting the NR PDCP entity to receive assistance information.
- [140] The Assistance Information Data frame may include radio quality assistance Information. The information shall consist of one or more of the information indicated in the Assistance Information Type.
- [141] The Assistance Information Data shall be sent when the corresponding node receives a DL USER DATA PDU including the Assistance Information Report Polling Flag set to 1.
- [142] The Assistance Information Data frame may include the PDCP Duplication Ac-

tivation Suggestion, which informs the node hosting the NR PDCP of the suggestion from the corresponding node on whether to activate or not activate PDCP duplication. The node hosting the NR PDCP may take this information into account to take a decision on whether to activate or not activate PDCP duplication.

[143] Furthermore, gNB-CU may receive UE Context Setup Response message or UE Context Modification Response message from gNB-DU. The UE Context Setup Response message or UE Context Modification Response message may include LCID for the primary path if PDCP duplication is applied.

[144] Table 1 shows an example of UE Context Setup Response message. This message is sent by the gNB-DU to confirm the setup of a UE context.

[145] [Table 1]

IE/Group Name	Presence	Range	IE type and reference	Semantics description	Criticality	Assigned Criticality
Message Type	M		9.3.1.1		YES	reject
gNB-CU UE F1AP ID	M		9.3.1.4		YES	reject
gNB-DU UE F1AP ID	M		9.3.1.5		YES	reject
...						
DRB Setup List		<i>0..1</i>		The List of DRBs which are successfully established.	YES	ignore
>DRB Setup Item List		<i>1 .. &lt;maxnoofDRBs&gt;</i>			EACH	ignore
>>DRB ID	M		9.3.1.8		-	
>>LCID	O		9.3.1.35	LCID for the primary path if PDCP duplication is applied		

[146] Table 2 shows an example of UE Context Modification Response message. This message is sent by the gNB-DU to confirm the modification of a UE context.

[147] [Table 2]

IE/Group Name	Presence	Range	IE type and reference	Semantics description	Criticality	Assigned Criticality
Message Type	M		9.3.1.1		YES	reject
gNB-CU UE F1AP ID	M		9.3.1.4		YES	reject
gNB-DU UE F1AP ID	M		9.3.1.5		YES	reject
...						
DRB Setup List		0..1		The List of DRBs which are successfully established.	YES	ignore
>DRB Setup Item IEs		1 .. <maxnoof DRBs>			EACH	ignore
>>DRB ID	M		9.3.1.8		-	
>>LCID	O		9.3.1.35	LCID for primary path if PDCP duplication is applied		
...						
DRB Modified List		0..1		The List of DRBs which are successfully modified.	YES	ignore
>DRB Modified		1 ..			EACH	ignore

Item IEs		<maxnoof DRBs>				
>>DRB ID	M		9.3.1.8		-	
>>LCID	O		9.3.1.35	LCID for primary path if PDCP du- plication is applied		

- [148] When duplication is applied/supported for CU-DU split, the above scheme may be performed as follows. First, the gNB-CU (i.e., the node hosting the NR PDCP) receives from the gNB-DU (i.e., the corresponding node) the PDCP Duplication Indication and PDCP Duplication Activation Suggestion included in the Assistance Information Data frame. The gNB-CU decides whether PDCP duplication should be activated or not. Then, the gNB-CU gets to know the primary path if PDCP duplication is applied by receiving the LCID information element (IE) contained in the UE Context Setup/Modification Response messages from the gNB-DU.
- [149] Meanwhile, for inter-gNB-DU duplicated transmission/fast re-transmission, there may be unnecessary resource utilization especially for AM mode DRBs. For example, current feedback from the corresponding node to the node hosting NR PDCP only includes the highest PDCP sequence number (SN) that is transmitted successfully to the UE in sequence. However, it is possible that other part of the data which share the same PDCP SN has already been transmitted successfully in the first leg and/or some PDCP PDUs are delivered to UE out of order in one leg. In this case, it is not necessary to re-transmit these data to save radio resources.
- [150] In detail, in case PDCP duplication is applied for inter-gNB-DU for intra-gNB-CU, the gNB-DUs transmit PDCP PDU with same PDCP SN to the UE. After sending the PDCP PDU to the UE, for AM mode DRBs, each gNB-DU provides the gNB-CU with feedback including the highest PDCP SN that is transmitted successfully to the UE in sequence. As mentioned above, however, it is possible that other part of the data which share the same PDCP SN has already been transmitted successfully at the first gNB-DU and/or some PDCP PDUs are delivered to the UE out of order at other gNB-DU. As a result, radio resource may be used so that other gNB-DU sends these PDCP PDUs which do not need to be transmitted.
- [151] Hereinafter, signaling between nodes, e.g., gNB-CU and gNB-DU, for resource allocation are described according to an embodiment of the present disclosure. The embodiment of the present disclosure proposes solutions for avoiding unnecessary

resource utilization at first gNB-DU to transmit PDCP PDUs which has already been sent successfully at second gNB-DU.

- [152] In some implementations of the present disclosure, the gNB-CU informs one gNB-DU among multiple gNB-DUs to which PDCP duplication is applied of removing allocated resource for PDCP PDUs which do not need to be transmitted based on the feedback information received from the multiple gNB-DUs. In some implementations of the present disclosure, the RRC and PDCP layers are located in the gNB-CU, and the RLC, MAC and PHY layers are located in the gNB-DU. Also, in some implementations of the present disclosure, it is assumed that the UE has DRB(s) which PDCP duplication is/are activated. According to the embodiment of the present disclosure, efficient resource allocation can be achieved.
- [153] FIG. 11 shows an example of a method for gNB-CU according to the embodiment of the present disclosure.
- [154] In step S1100, the gNB-CU establishes connection to a first gNB-DU and a second gNB-DU. In step S1110, the gNB-CU transmits DL data to a wireless device via the first gNB-DU and the second gNB-DU.
- [155] In step S1120, the gNB-CU receives a delivery status of the DL data from the first gNB-DU and the second gNB-DU. The delivery status of the DL data may include a feedback about in-sequence delivery status of the DL data. The feedback may include a highest successfully delivered PDCP SN of the DL data.
- [156] In step S1130, the gNB-CU determines that PDCP PDU from the DL data does not need to be transmitted to the wireless device based on the delivery status of the DL data. The gNB-CU may determine that the PDCP PDU does not need to be transmitted based on difference between the delivery status (e.g., PDCP SNs) of the DL data received from each of the first gNB-DU and the second gNB-DU.
- [157] In step S1140, the gNB-CU transmits an indication to at least one gNB-DU among the first gNB-DU and the second gNB-DU. The at least one gNB-DU has the PDCP PDU which does not need to be transmitted to the wireless device. The indication may include a PDCP PDU remove indication informing removal of resources for transmitting the PDCU PDU which does not need to be transmitted to the wireless device. The indication may include information for a start and end of PDCP SNs related to the PDCP PDU which does not need to be transmitted to the wireless device.
- [158] According to the embodiment of the present disclosure shown in FIG. 11, in case of PDCP duplication, the gNB-CU can inform one gNB-DU which has PDCP PDUs which has already been sent successfully at other gNB-DU. It is possible to avoid unnecessary resource utilization at first gNB-DU to transmit PDCP PDUs which has already been sent successfully at second gNB-DU and vice versa.
- [159] FIG. 12 shows an example of a method for gNB-DU according to the embodiment of

the present disclosure.

- [160] In step S1200, the gNB-DU establishes connection to a gNB-CU. In step S1210, the gNB-DU transmits DL data received from the gNB-CU to a wireless device.
- [161] In step S1220, the gNB-DU transmits a delivery status of the DL data to the gNB-CU. The delivery status of the DL data may include a feedback about in-sequence delivery status of the DL data. The feedback may include a highest successfully delivered PDCP SN of the DL data.
- [162] In step S1230, the gNB-DU receives an indication indicating removal of resources for transmitting a PDCP PDU from the DL data which does not need to be transmitted to the wireless device from the gNB-CU. The indication may include information for a start and end of PDCP SNs related to the PDCP PDU which does not need to be transmitted to the wireless device.
- [163] In step S1240, the gNB-DU removes the resources for transmitting the PDCP PDU based on the indication.
- [164] According to the embodiment of the present disclosure shown in FIG. 12, in case of PDCP duplication, the gNB-DU which has PDCP PDUs which has already been sent successfully at other gNB-DU can remove resources to transmit the PDCP PDUs which does not need to be transmitted to the wireless device. It is possible to avoid unnecessary resource utilization at first gNB-DU to transmit PDCP PDUs which has already been sent successfully at second gNB-DU and vice versa. Therefore, gNB-DUs within the same gNB-CU can use radio resource efficiently.
- [165] FIG. 13 shows an example of a procedure for inter-gNB-DU PDCP duplication according to the embodiment of the present disclosure.
- [166] Step S1300: The UE is connected to the gNB-DU at RRC and PDCP level. The UE has DRB(s) to which PDCP duplication is activated. It is assumed that PDCP duplication is activated at gNB-DU1 and gNB-DU2. The UE may receive the duplicated data from the gNB-DU1 and gNB-DU2.
- [167] Step S1311/S1312: gNB-DU1 and/or gNB-DU2 send(s) the DL Data Delivery Status message to the gNB-CU over the F1-U interface. The DL Data Delivery Status message may include the *Highest successfully delivered* NR PDCP Sequence Number IE. The *Highest successfully delivered* NR PDCP Sequence Number IE may inform feedback about the in-sequence delivery status of NR PDCP PDUs at the gNB-DU1 and/or gNB-DU2 towards the UE.
- [168] Step S1320: Upon receiving the DL Data Delivery Status message from the gNB-DU1 and/or gNB-DU2, the gNB-CU decides which PDCP PDUs do not need to be transmitted. The gNB-CU may determine PDCP PDUs which do not need to be transmitted based on feedback information (e.g., PDCP SNs) within the received DL Data Delivery Status message(s) and which gNB-DU has PDCP PDUs related to these

PDCP SNs. If the DL Data Delivery Status messages are received from both the gNB-DU1 and gNB-DU2, the gNB-CU may obtain PDCP SNs which are unnecessary to be transmitted based on difference between received PDCP SNs. If the DL Data Delivery Status message is received only from one of the gNB-DU1 or gNB-DU2, the gNB-CU may determine the PDCP SNs which do not need to be sent based on difference between PDCP SN received from the gNB-DU1 (or gNB-DU2) and PDCP SN received from gNB-DU2 (or gNB-DU1) in the last time respectively.

[169] Step S1331/S1332: The gNB-CU transmits the DL User Data (or new message) over the F1-U interface to the gNB-DU1 and gNB-DU2. In this example, it is assumed that the gNB-DU1 has PDCP PDUs which do not need to be transmitted. Therefore, in step S1331, the gNB-CU transmits the DL User Data including an indication to the gNB-DU1 which has PDCP PDUs which do not need to be transmitted. The indication may include a remove PDCP PDU indication. The remove PDCP PDU indication may inform removal of allocated resource for transmitting PDCP PDUs which are unnecessary to be sent. The indication may also contain the *Start of removed* NR-U Sequence Number range and *End of removed* NR-U Sequence Number range to inform a beginning and an end of PDCP SNs related to the PDCP PDUs which do not need to be transmitted. In step S1332, the gNB-CU may transmit the DL User Data without the indication to the gNB-DU2.

[170] In step S1340: Upon receiving the DL User Data including the indication from the gNB-CU, the gNB-DU1 removes resource allocated to the PDCP PDUs which do not need to be transmitted, i.e., PDCP SNs between the received two range values. The gNB-DU1 may discard these PDCP PDUs.

[171] According to the embodiment of the present disclosure shown in FIG. 13, in case of PDCP duplication, it is possible to avoid unnecessary resource utilization at first gNB-DU to transmit PDCP PDUs which has already been sent successfully at second gNB-DU and vice versa. Therefore, gNB-DUs within the same gNB-CU can use radio resource efficiently. In addition, UE's experience can be enhanced (e.g., support of ultra-reliable low latency communication (URLLC)) when PDCP duplication is applied.

[172] The present disclosure may be applied to various future technologies, such as AI.

[173] <AI>

[174] AI refers to artificial intelligence and/or the field of studying methodology for making it. Machine learning is a field of studying methodologies that define and solve various problems dealt with in AI. Machine learning may be defined as an algorithm that enhances the performance of a task through a steady experience with any task.

[175] An artificial neural network (ANN) is a model used in machine learning. It can mean a whole model of problem-solving ability, consisting of artificial neurons (nodes) that

form a network of synapses. An ANN can be defined by a connection pattern between neurons in different layers, a learning process for updating model parameters, and/or an activation function for generating an output value. An ANN may include an input layer, an output layer, and optionally one or more hidden layers. Each layer may contain one or more neurons, and an ANN may include a synapse that links neurons to neurons. In an ANN, each neuron can output a summation of the activation function for input signals, weights, and deflections input through the synapse. Model parameters are parameters determined through learning, including deflection of neurons and/or weights of synaptic connections. The hyper-parameter means a parameter to be set in the machine learning algorithm before learning, and includes a learning rate, a repetition number, a mini batch size, an initialization function, etc. The objective of the ANN learning can be seen as determining the model parameters that minimize the loss function. The loss function can be used as an index to determine optimal model parameters in learning process of ANN.

[176] Machine learning can be divided into supervised learning, unsupervised learning, and reinforcement learning, depending on the learning method. Supervised learning is a method of learning ANN with labels given to learning data. Labels are the answers (or result values) that ANN must infer when learning data is input to ANN. Unsupervised learning can mean a method of learning ANN without labels given to learning data. Reinforcement learning can mean a learning method in which an agent defined in an environment learns to select a behavior and/or sequence of actions that maximizes cumulative compensation in each state.

[177] Machine learning, which is implemented as a deep neural network (DNN) that includes multiple hidden layers among ANN, is also called deep learning. Deep learning is part of machine learning. In the following, machine learning is used to mean deep learning.

[178] FIG. 14 shows an example of an AI device to which the technical features of the present disclosure can be applied.

[179] The AI device 1400 may be implemented as a stationary device or a mobile device, such as a TV, a projector, a mobile phone, a smartphone, a desktop computer, a notebook, a digital broadcasting terminal, a PDA, a PMP, a navigation device, a tablet PC, a wearable device, a set-top box (STB), a digital multimedia broadcasting (DMB) receiver, a radio, a washing machine, a refrigerator, a digital signage, a robot, a vehicle, etc.

[180] Referring to FIG. 14, the AI device 1400 may include a communication part 1410, an input part 1420, a learning processor 1430, a sensing part 1440, an output part 1450, a memory 1460, and a processor 1470.

[181] The communication part 1410 can transmit and/or receive data to and/or from

external devices such as the AI devices and the AI server using wire and/or wireless communication technology. For example, the communication part 1410 can transmit and/or receive sensor information, a user input, a learning model, and a control signal with external devices. The communication technology used by the communication part 1410 may include a global system for mobile communication (GSM), a code division multiple access (CDMA), an LTE/LTE-A, a 5G, a WLAN, a Wi-Fi, Bluetooth™, radio frequency identification (RFID), infrared data association (IrDA), ZigBee, and/or near field communication (NFC).

[182] The input part 1420 can acquire various kinds of data. The input part 1420 may include a camera for inputting a video signal, a microphone for receiving an audio signal, and a user input part for receiving information from a user. A camera and/or a microphone may be treated as a sensor, and a signal obtained from a camera and/or a microphone may be referred to as sensing data and/or sensor information. The input part 1420 can acquire input data to be used when acquiring an output using learning data and a learning model for model learning. The input part 1420 may obtain raw input data, in which case the processor 1470 or the learning processor 1430 may extract input features by preprocessing the input data.

[183] The learning processor 1430 may learn a model composed of an ANN using learning data. The learned ANN can be referred to as a learning model. The learning model can be used to infer result values for new input data rather than learning data, and the inferred values can be used as a basis for determining which actions to perform. The learning processor 1430 may perform AI processing together with the learning processor of the AI server. The learning processor 1430 may include a memory integrated and/or implemented in the AI device 1400. Alternatively, the learning processor 1430 may be implemented using the memory 1460, an external memory directly coupled to the AI device 1400, and/or a memory maintained in an external device.

[184] The sensing part 1440 may acquire at least one of internal information of the AI device 1400, environment information of the AI device 1400, and/or the user information using various sensors. The sensors included in the sensing part 1440 may include a proximity sensor, an illuminance sensor, an acceleration sensor, a magnetic sensor, a gyro sensor, an inertial sensor, an RGB sensor, an IR sensor, a fingerprint recognition sensor, an ultrasonic sensor, an optical sensor, a microphone, a light detection and ranging (LIDAR), and/or a radar.

[185] The output part 1450 may generate an output related to visual, auditory, tactile, etc. The output part 1450 may include a display unit for outputting visual information, a speaker for outputting auditory information, and/or a haptic module for outputting tactile information.

- [186] The memory 1460 may store data that supports various functions of the AI device 1400. For example, the memory 1460 may store input data acquired by the input part 1420, learning data, a learning model, a learning history, etc.
- [187] The processor 1470 may determine at least one executable operation of the AI device 1400 based on information determined and/or generated using a data analysis algorithm and/or a machine learning algorithm. The processor 1470 may then control the components of the AI device 1400 to perform the determined operation. The processor 1470 may request, retrieve, receive, and/or utilize data in the learning processor 1430 and/or the memory 1460, and may control the components of the AI device 1400 to execute the predicted operation and/or the operation determined to be desirable among the at least one executable operation. The processor 1470 may generate a control signal for controlling the external device, and may transmit the generated control signal to the external device, when the external device needs to be linked to perform the determined operation. The processor 1470 may obtain the intention information for the user input and determine the user's requirements based on the obtained intention information. The processor 1470 may use at least one of a speech-to-text (STT) engine for converting speech input into a text string and/or a natural language processing (NLP) engine for acquiring intention information of a natural language, to obtain the intention information corresponding to the user input. At least one of the STT engine and/or the NLP engine may be configured as an ANN, at least a part of which is learned according to a machine learning algorithm. At least one of the STT engine and/or the NLP engine may be learned by the learning processor 1430 and/or learned by the learning processor of the AI server, and/or learned by their distributed processing. The processor 1470 may collect history information including the operation contents of the AI device 1400 and/or the user's feedback on the operation, etc. The processor 1470 may store the collected history information in the memory 1460 and/or the learning processor 1430, and/or transmit to an external device such as the AI server. The collected history information can be used to update the learning model. The processor 1470 may control at least some of the components of AI device 1400 to drive an application program stored in memory 1460. Furthermore, the processor 1470 may operate two or more of the components included in the AI device 1400 in combination with each other for driving the application program.
- [188] FIG. 15 shows an example of an AI system to which the technical features of the present disclosure can be applied.
- [189] Referring to FIG. 15, in the AI system, at least one of an AI server 1520, a robot 1510a, an autonomous vehicle 1510b, an XR device 1510c, a smartphone 1510d and/or a home appliance 1510e is connected to a cloud network 1500. The robot 1510a, the autonomous vehicle 1510b, the XR device 1510c, the smartphone 1510d, and/or the

home appliance 1510e to which the AI technology is applied may be referred to as AI devices 1510a to 1510e.

[190] The cloud network 1500 may refer to a network that forms part of a cloud computing infrastructure and/or resides in a cloud computing infrastructure. The cloud network 1500 may be configured using a 3G network, a 4G or LTE network, and/or a 5G network. That is, each of the devices 1510a to 1510e and 1520 constituting the AI system may be connected to each other through the cloud network 1500. In particular, each of the devices 1510a to 1510e and 1520 may communicate with each other through a base station, but may directly communicate with each other without using a base station.

[191] The AI server 1520 may include a server for performing AI processing and a server for performing operations on big data. The AI server 1520 is connected to at least one or more of AI devices constituting the AI system, i.e., the robot 1510a, the autonomous vehicle 1510b, the XR device 1510c, the smartphone 1510d and/or the home appliance 1510e through the cloud network 1500, and may assist at least some AI processing of the connected AI devices 1510a to 1510e. The AI server 1520 can learn the ANN according to the machine learning algorithm on behalf of the AI devices 1510a to 1510e, and can directly store the learning models and/or transmit them to the AI devices 1510a to 1510e. The AI server 1520 may receive the input data from the AI devices 1510a to 1510e, infer the result value with respect to the received input data using the learning model, generate a response and/or a control command based on the inferred result value, and transmit the generated data to the AI devices 1510a to 1510e. Alternatively, the AI devices 1510a to 1510e may directly infer a result value for the input data using a learning model, and generate a response and/or a control command based on the inferred result value.

[192] Various embodiments of the AI devices 1510a to 1510e to which the technical features of the present disclosure can be applied will be described. The AI devices 1510a to 1510e shown in FIG. 15 can be seen as specific embodiments of the AI device 1400 shown in FIG. 14.

[193] In view of the exemplary systems described herein, methodologies that may be implemented in accordance with the disclosed subject matter have been described with reference to several flow diagrams. While for purposes of simplicity, the methodologies are shown and described as a series of steps or blocks, it is to be understood and appreciated that the claimed subject matter is not limited by the order of the steps or blocks, as some steps may occur in different orders or concurrently with other steps from what is depicted and described herein. Moreover, one skilled in the art would understand that the steps illustrated in the flow diagram are not exclusive and other steps may be included or one or more of the steps in the example flow diagram

may be deleted without affecting the scope of the present disclosure.

[194] Claims in the present description can be combined in a various way. For instance, technical features in method claims of the present description can be combined to be implemented or performed in an apparatus, and technical features in apparatus claims can be combined to be implemented or performed in a method. Further, technical features in method claim(s) and apparatus claim(s) can be combined to be implemented or performed in an apparatus. Further, technical features in method claim(s) and apparatus claim(s) can be combined to be implemented or performed in a method. Other implementations are within the scope of the following claims.

## Claims

- [Claim 1] A method for a gNB central unit (gNB-CU) in a wireless communication system, the method comprising:  
establishing connection to a first gNB distributed unit (gNB-DU) and a second gNB-DU;  
transmitting downlink (DL) data to a wireless device via the first gNB-DU and the second gNB-DU;  
receiving a delivery status of the DL data from the first gNB-DU and the second gNB-DU;  
determining that a packet data convergence protocol (PDCP) protocol data unit (PDU) from the DL data does not need to be transmitted to the wireless device based on the delivery status of the DL data; and  
transmitting an indication to at least one gNB-DU among the first gNB-DU and the second gNB-DU, wherein the at least one gNB-DU has the PDCP PDU which does not need to be transmitted to the wireless device.
- [Claim 2] The method of claim 1, wherein the indication includes a PDCP PDU remove indication informing removal of resources for transmitting the PDCP PDU which does not need to be transmitted to the wireless device.
- [Claim 3] The method of claim 1, wherein the indication includes information for a start and end of PDCP sequence numbers (SNs) related to the PDCP PDU which does not need to be transmitted to the wireless device.
- [Claim 4] The method of claim 1, wherein the delivery status of the DL data includes a feedback about in-sequence delivery status of the DL data.
- [Claim 5] The method of claim 4, wherein the feedback includes a highest successfully delivered PDCP SN of the DL data.
- [Claim 6] The method of claim 1, wherein it is determined that the PDCP PDU does not need to be transmitted based on difference between the delivery status of the DL data received from each of the first gNB-DU and the second gNB-DU.
- [Claim 7] The method of claim 1, wherein the gNB-CU is a logical node constituting a gNB that hosts a radio resource control (RRC) layer and a packet data convergence protocol (PDCP) layer.
- [Claim 8] The method of claim 1, wherein the wireless device is in communication with at least one of a mobile terminal, a network, and/or autonomous vehicles other than the wireless device.

- [Claim 9] A method for a gNB distributed unit (gNB-DU) in a wireless communication system, the method comprising:  
establishing connection to a gNB central unit (gNB-CU);  
transmitting downlink (DL) data received from the gNB-CU to a wireless device;  
transmitting a delivery status of the DL data to the gNB-CU;  
receiving an indication indicating removal of resources for transmitting a packet data convergence protocol (PDCP) protocol data unit (PDU) from the DL data which does not need to be transmitted to the wireless device from the gNB-CU; and  
removing the resources for transmitting the PDCP PDU based on the indication.
- [Claim 10] The method of claim 9, wherein the indication includes information for a start and end of PDCP sequence numbers (SNs) related to the PDCP PDU which does not need to be transmitted to the wireless device.
- [Claim 11] The method of claim 9, wherein the delivery status of the DL data includes a feedback about in-sequence delivery status of the DL data.
- [Claim 12] The method of claim 11, wherein the feedback includes a highest successfully delivered PDCP SN of the DL data.
- [Claim 13] The method of claim 9, wherein the gNB-DU is a logical node constituting a gNB that hosts a radio link control (RLC) layer, a media access control (MAC) layer and a physical layer.

[Fig. 1]

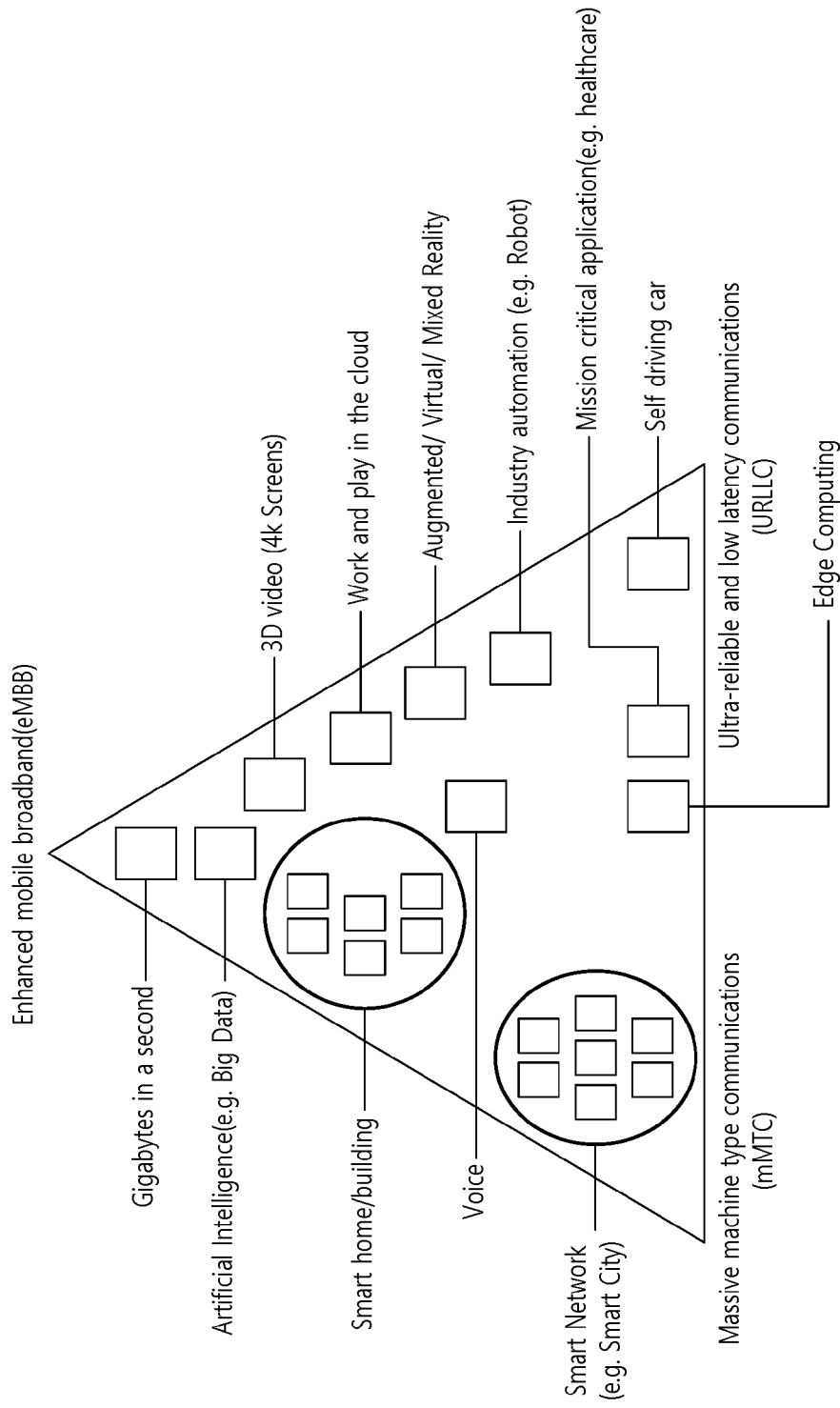

[Fig. 2]

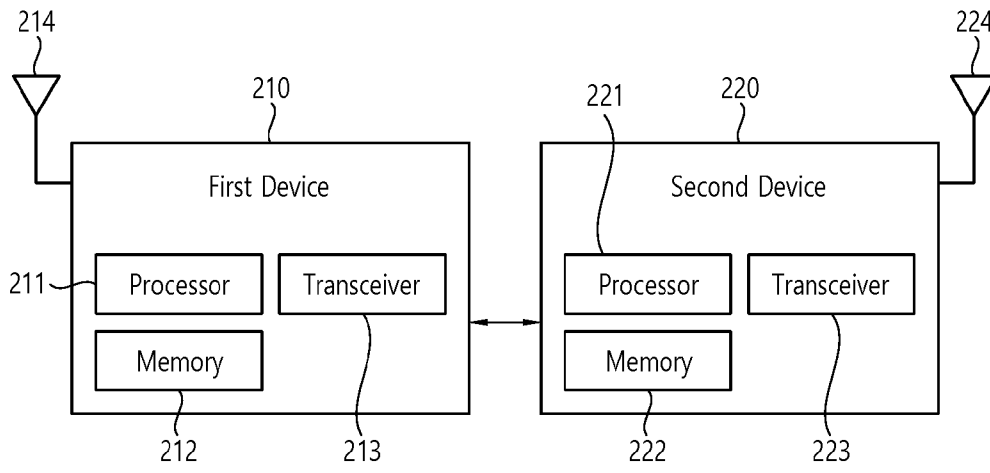

[Fig. 3]

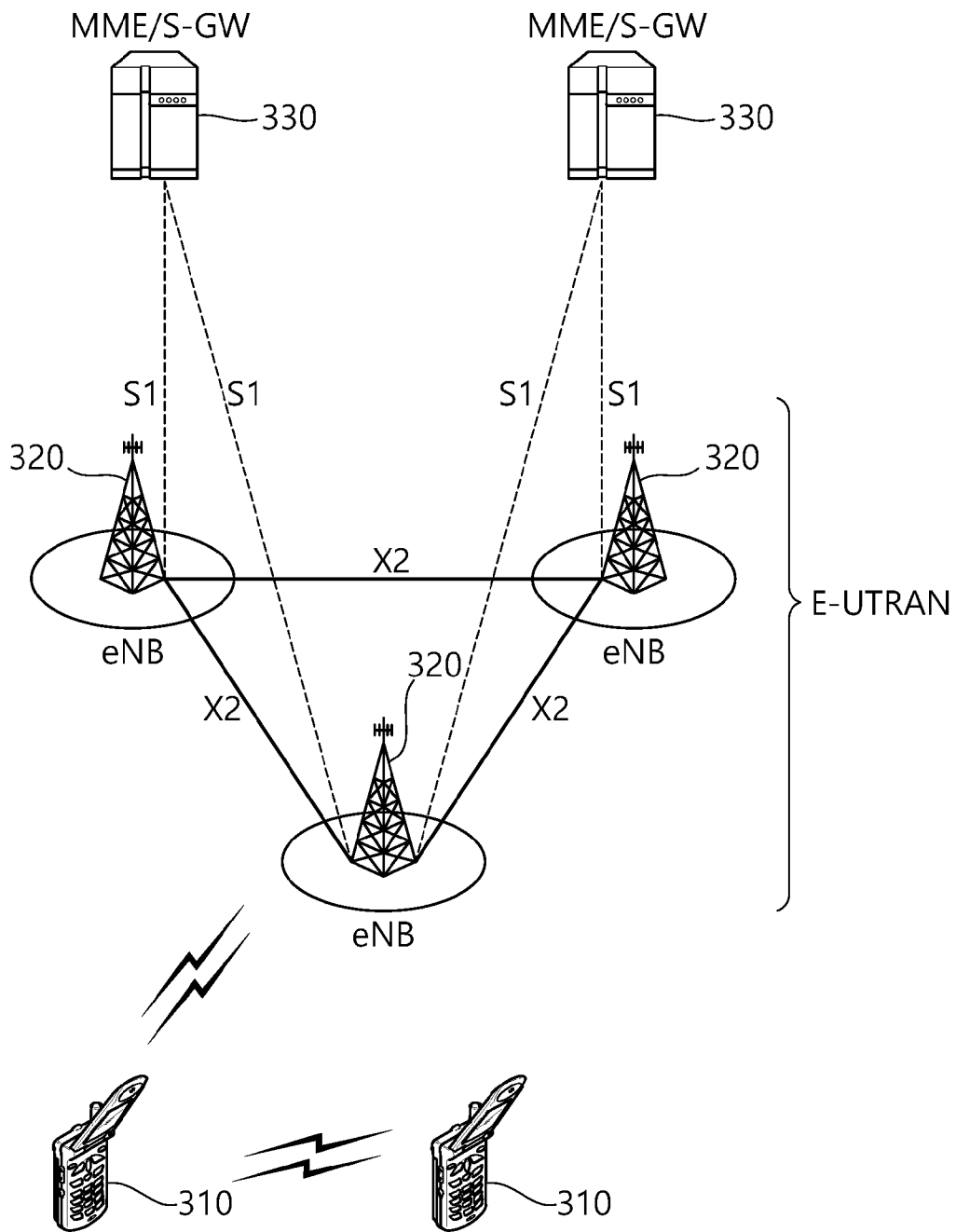

[Fig. 4]

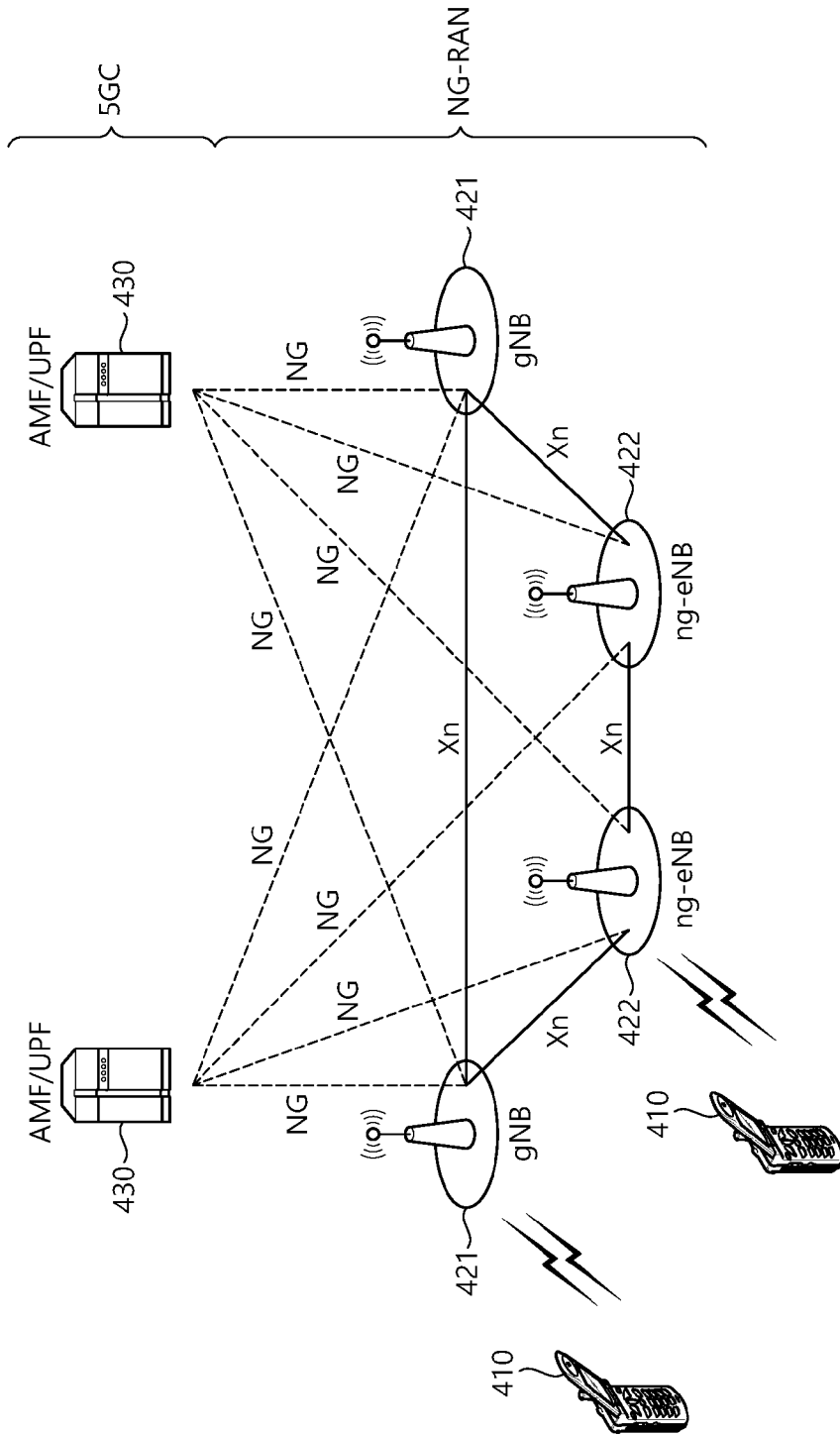

[Fig. 5]

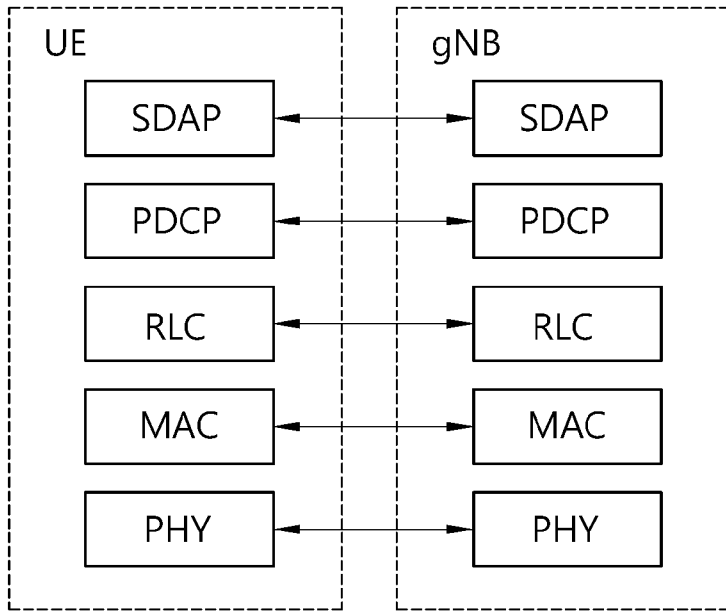

[Fig. 6]

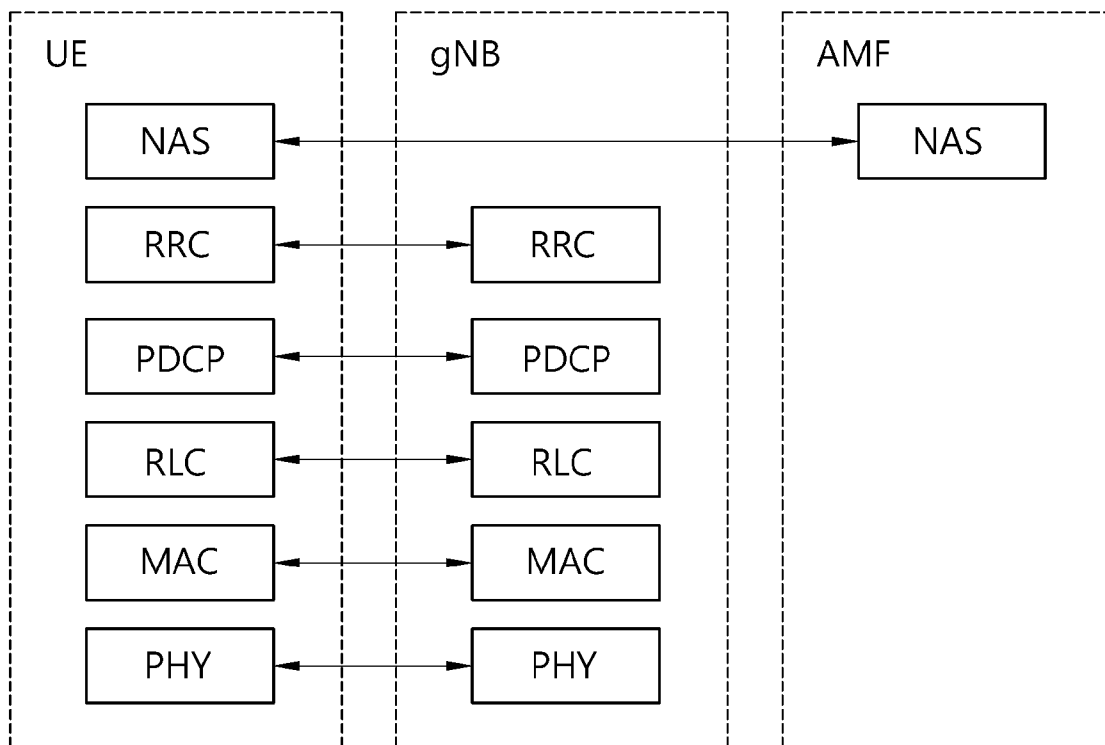

[Fig. 7]

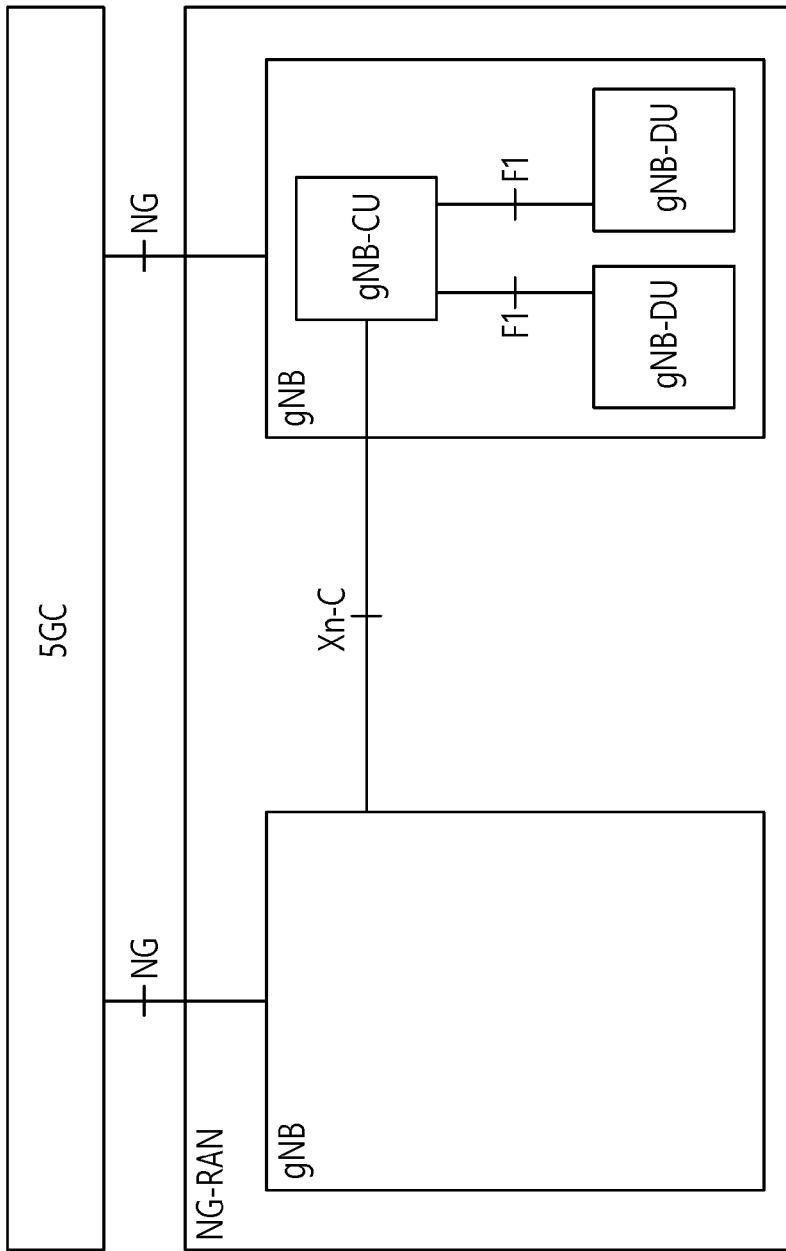

[Fig. 8]

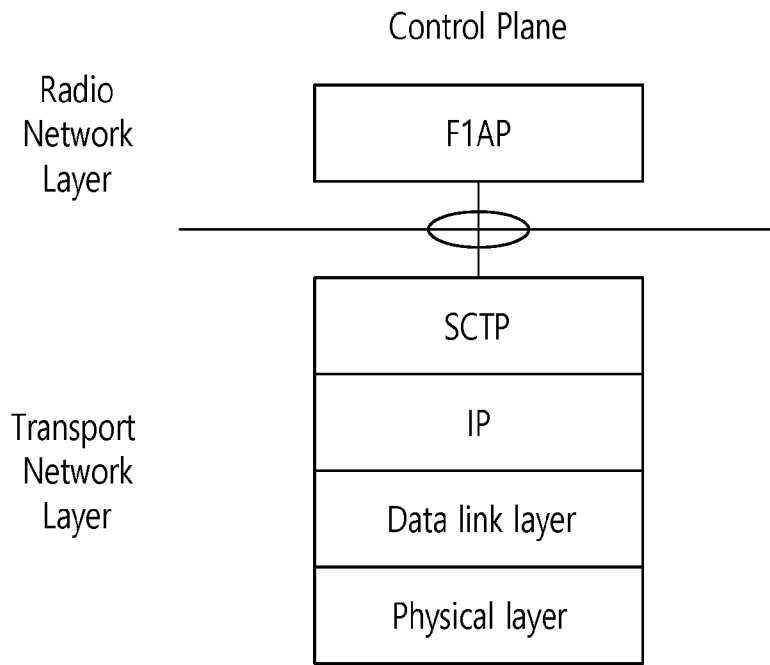

[Fig. 9]

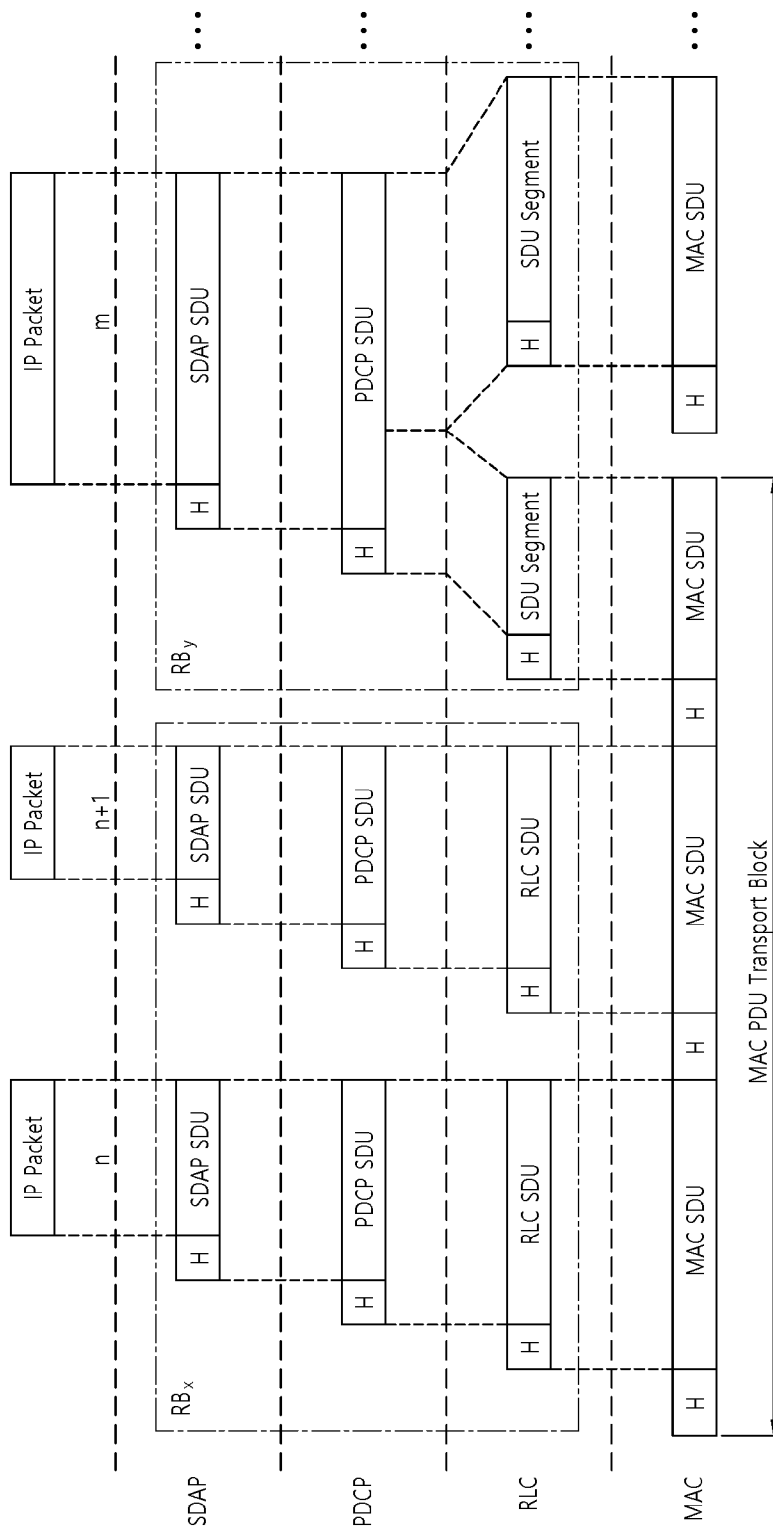

[Fig. 10]

Bits								Number of Octets
7	6	5	4	3	2	1	0	
PDU Type (=2)				PDCP Dupl. Ind.	Spare			1
Spare							PDCP Duplication Activation Suggestion	1
Number of Assistance Information Fields								0 or 1
Assistance Information Type								0 or (2*Number of Assistance Info Field)
Radio Quality Assistance Information								

[Fig. 11]

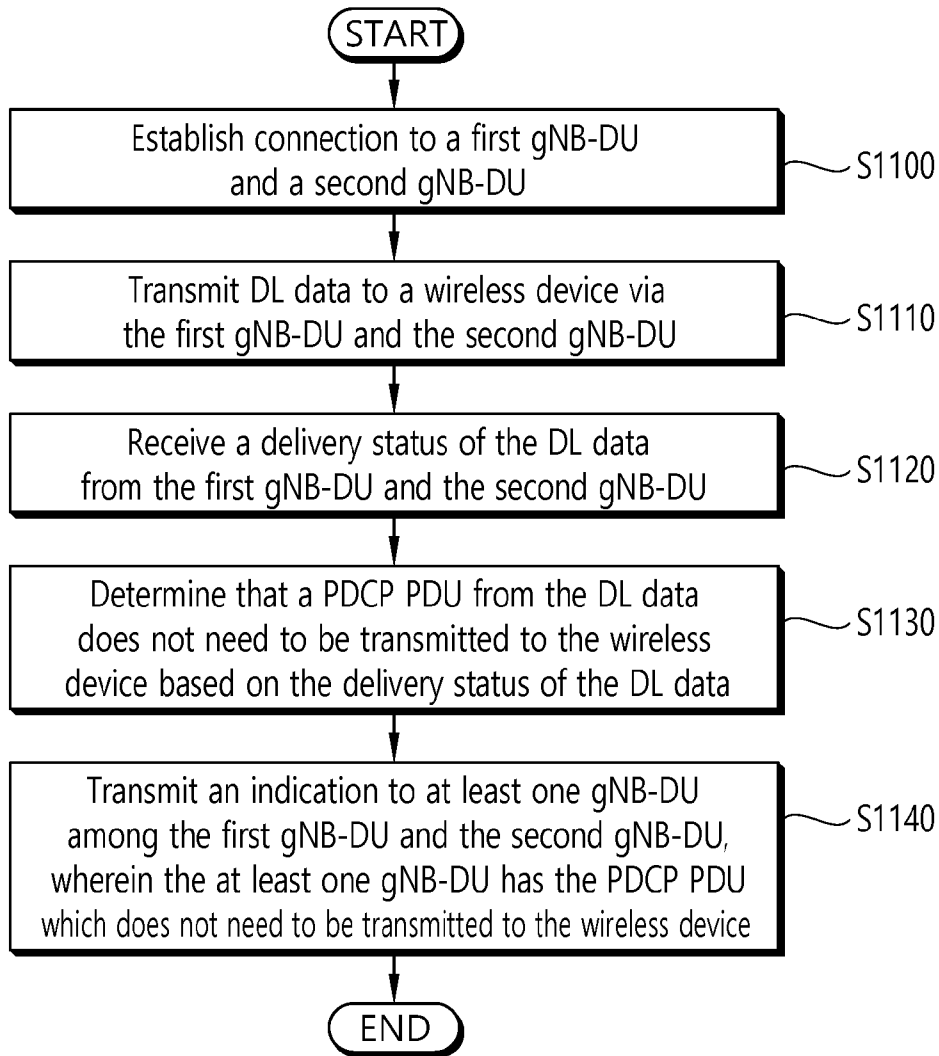

[Fig. 12]

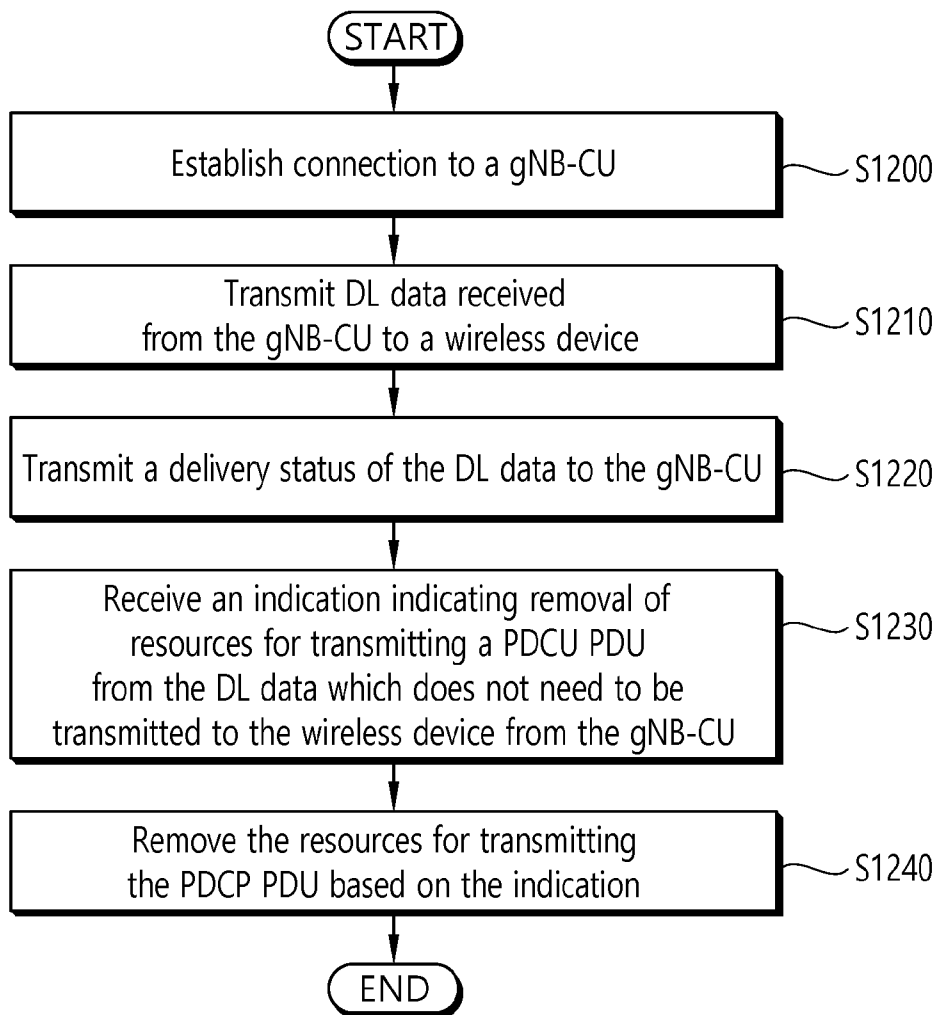

[Fig. 13]

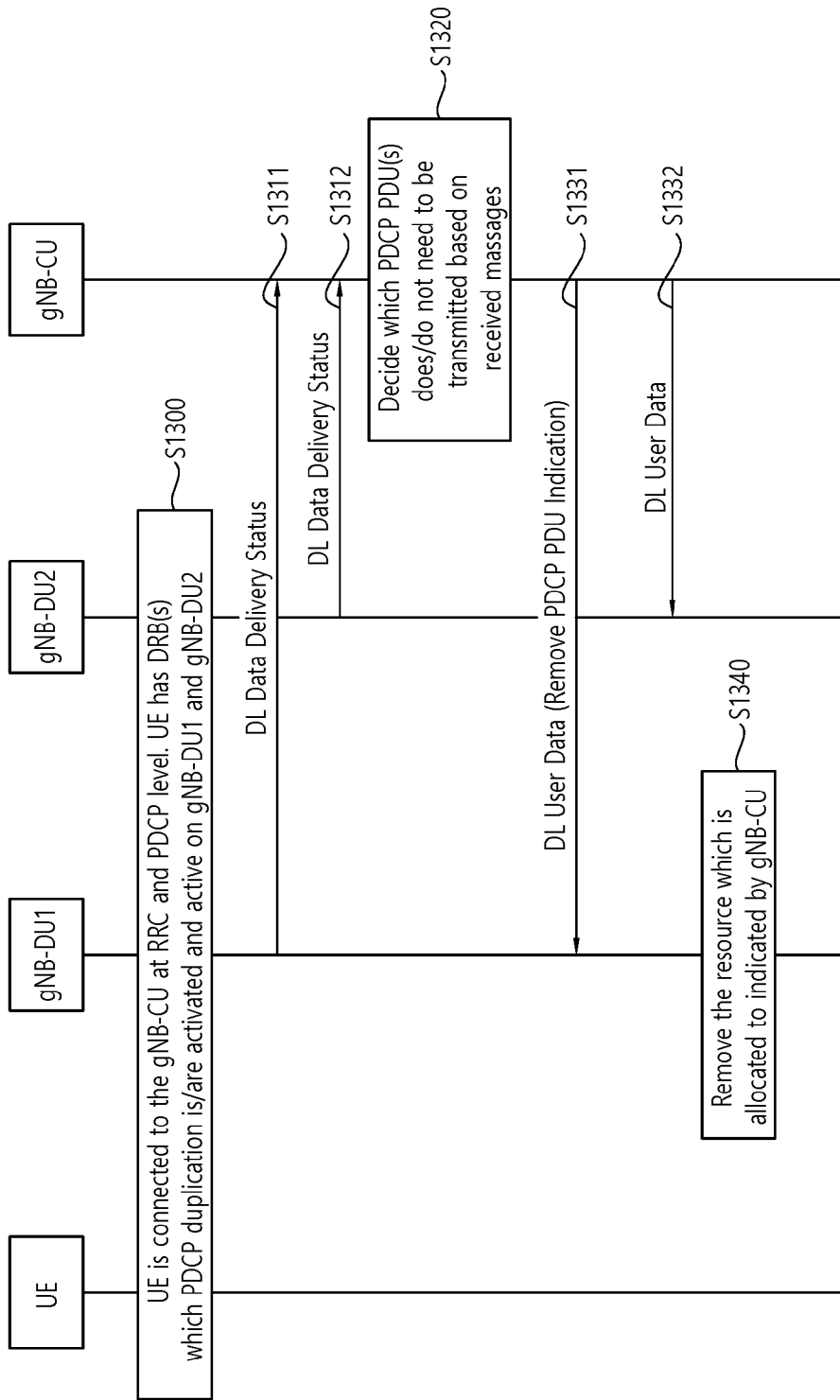

[Fig. 14]

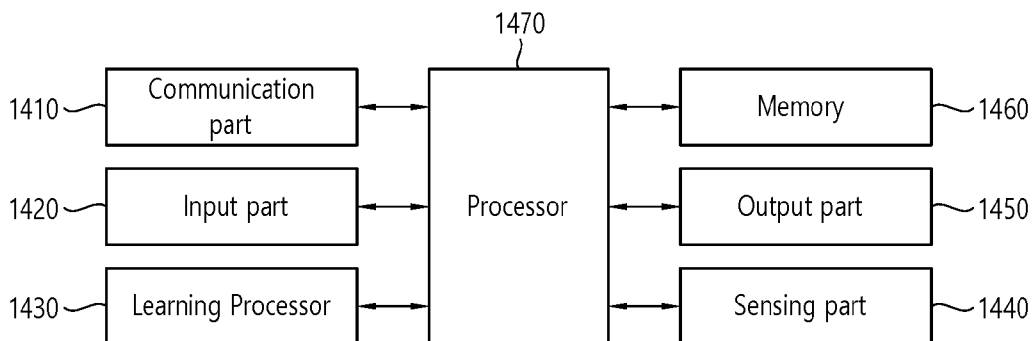

[Fig. 15]

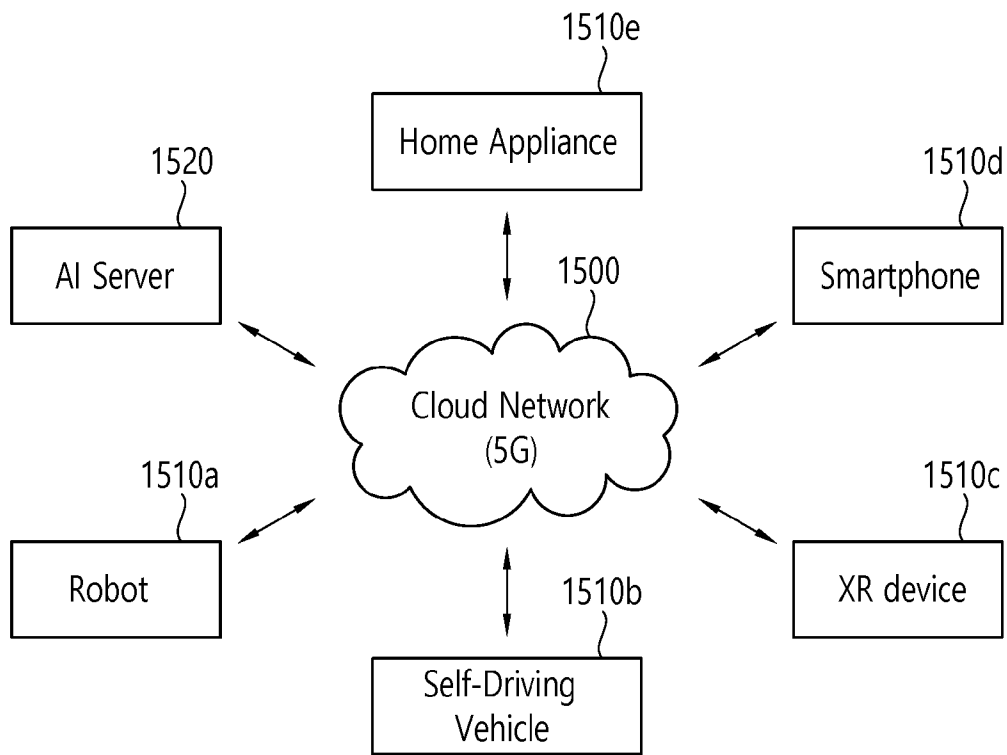

## INTERNATIONAL SEARCH REPORT

International application No.  
**PCT/KR2019/011976****A. CLASSIFICATION OF SUBJECT MATTER****H04L 5/00(2006.01)i, H04L 27/26(2006.01)i, H04L 29/06(2006.01)i**

According to International Patent Classification (IPC) or to both national classification and IPC

**B. FIELDS SEARCHED**Minimum documentation searched (classification system followed by classification symbols)  
H04L 5/00; H04W 76/11; H04W 76/12; H04L 27/26; H04L 29/06Documentation searched other than minimum documentation to the extent that such documents are included in the fields searched  
Korean utility models and applications for utility models  
Japanese utility models and applications for utility modelsElectronic data base consulted during the international search (name of data base and, where practicable, search terms used)  
eKOMPASS(KIPO internal) & keywords: gNB-CU, gNB-DU, DL data, PDCP PDU, indication, removal, sequence numbers, delivery status, in-sequence, feedback, difference, RRC**C. DOCUMENTS CONSIDERED TO BE RELEVANT**

Category*	Citation of document, with indication, where appropriate, of the relevant passages	Relevant to claim No.
Y	3GPP TS 38.401 v15.2.0, '3GPP; TSGRAN; NG-RAN; Architecture description (Release 15)', 22 June 2018 See sections 3.1, 8.2.1.1, 8.3.1; and figures 8.2.1.1-1, 8.3.1-1.	1-13
Y	ERICSSON, 'Final Frame Indication', R3-182754, 3GPP TSG-RAN WG3 Meeting #100, Busan, South Korea, 11 May 2018 See section 2.	1-13
Y	3GPP TS 38.425 v15.2.0, '3GPP; TSGRAN; NG-RAN; NR user plane protocol (Release 15)', 22 June 2018 See sections 5.5.3.10, 5.5.3.19.	3-5,10-12
A	ZTE, 'Discussion on IAB link switch and topology adaptation', R2-1812467, 3GPP TSG-RAN WG2#103, Gothenburg, Sweden, 10 August 2018 See section 2.	1-13
A	US 2018-0213579 A1 (KT CORPORATION) 26 July 2018 See paragraphs [0071]-[0099].	1-13

 Further documents are listed in the continuation of Box C. See patent family annex.

\* Special categories of cited documents:

"A" document defining the general state of the art which is not considered to be of particular relevance

"D" document cited by the applicant in the international application

"E" earlier application or patent but published on or after the international filing date

"L" document which may throw doubts on priority claim(s) or which is cited to establish the publication date of another citation or other special reason (as specified)

"O" document referring to an oral disclosure, use, exhibition or other means

"P" document published prior to the international filing date but later than the priority date claimed

"T" later document published after the international filing date or priority date and not in conflict with the application but cited to understand the principle or theory underlying the invention

"X" document of particular relevance; the claimed invention cannot be considered novel or cannot be considered to involve an inventive step when the document is taken alone

"Y" document of particular relevance; the claimed invention cannot be considered to involve an inventive step when the document is combined with one or more other such documents, such combination being obvious to a person skilled in the art

"&amp;" document member of the same patent family

Date of the actual completion of the international search

24 December 2019 (24.12.2019)

Date of mailing of the international search report

**24 December 2019 (24.12.2019)**

Name and mailing address of the ISA/KR

International Application Division  
Korean Intellectual Property Office  
189 Cheongsa-ro, Seo-gu, Daejeon, 35208, Republic of Korea

Facsimile No. +82-42-481-8578

Authorized officer

KWON, Sung Ho

Telephone No. +82-42-481-3547



**INTERNATIONAL SEARCH REPORT**

Information on patent family members

International application No.

**PCT/KR2019/011976**

Patent document cited in search report	Publication date	Patent family member(s)	Publication date
US 2018-0213579 A1	26/07/2018	KR 10-2016-0135090 A WO 2017-010693 A1	24/11/2016 19/01/2017