

[54] **DISPENSER FOR C-WASHERS AND THE LIKE AND WASHER PACKAGE FOR USE WITH DISPENSER**

[75] Inventors: **Peter Benzing**, Munchingen; **Richard Klein**, Berkheim; **Alfred Trampisch**, Stuttgart-Zuffenhausen, all of Germany

[73] Assignee: **Hugo Benzing oHG**, Munchingen, Germany

[22] Filed: **Nov. 16, 1967**

[21] Appl. No.: **683,598**

[30] **Foreign Application Priority Data**

Nov. 11, 1966 Germany.....B 89975
Jan. 17, 1967 Germany.....B 90764

[52] U.S. Cl.....**206/65 R, 206/56 DF**

[51] Int. Cl.....**B65d 85/58, B65d 85/62**

[58] Field of Search.....**206/56 A, 56 DF, 206/56 A, 65, 0.82; 229/87.2; 53/26, 30; 83/701; 30/2**

[56] **References Cited**

UNITED STATES PATENTS

209,585	11/1878	Raymond et al.	206/0.82
2,810,243	10/1957	Mellowes	53/26
2,985,295	5/1961	Erdmann	206/65 B
3,055,163	9/1962	Ramseier	206/65
3,187,477	6/1965	Dreyfus	53/30
3,341,110	9/1967	Warfel	229/87.2
3,357,554	12/1967	Walter	206/65

Primary Examiner—William T. Dixon, Jr.
Attorney—Richard Low

[57] **ABSTRACT**

C-Washers are packaged in a tubular plastic envelope by sliding the washers over a carrier bar, inserting the coaxially stacked washers on the bar into a loosely fitting plastic tube, contracting the tube by shrinkage or otherwise until it conformingly engages the washers and secures them in aligned position, and withdrawing the carrier bar. The dispenser has a guide rail similar to the carrier and a cutting blade near one end of the guide rail and obliquely inclined relative to the direction of rail elongation which slits the tube when the stack of washers is slipped over the guide rail so that the tube may be peeled off.

3 Claims, 11 Drawing Figures

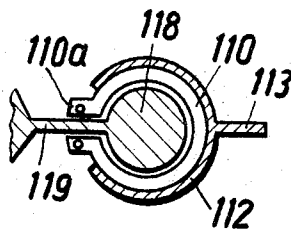

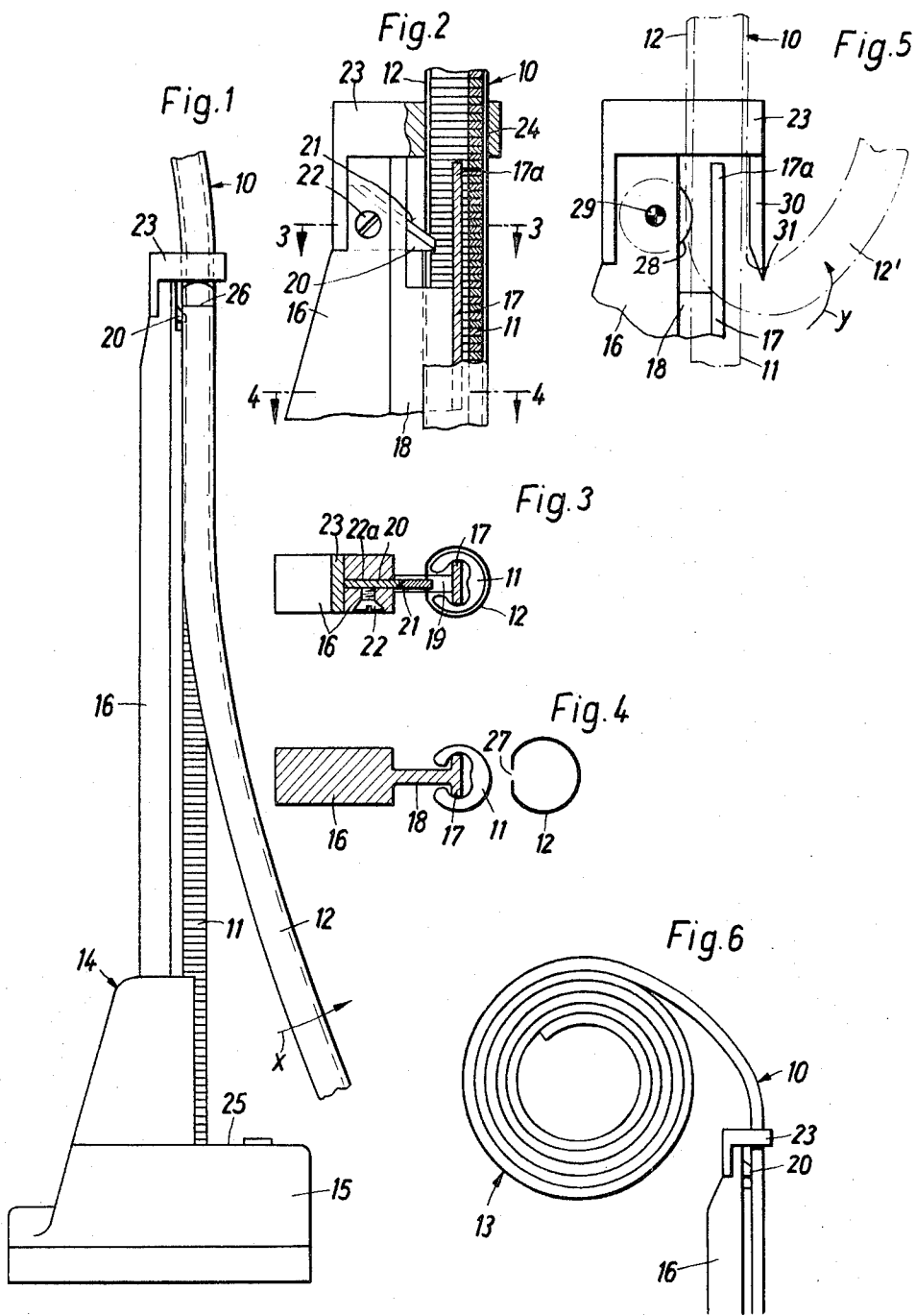

Inventors
Peter Benzing, Richard
Klein, Alfred Trampisch
By Richard Lind
att

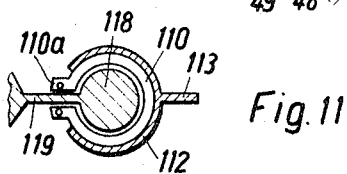
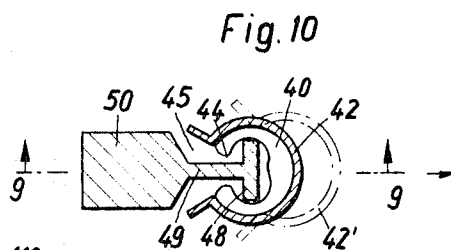
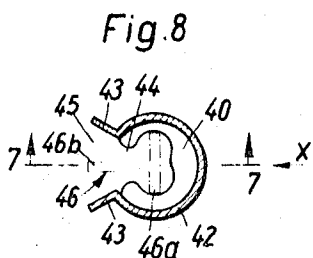
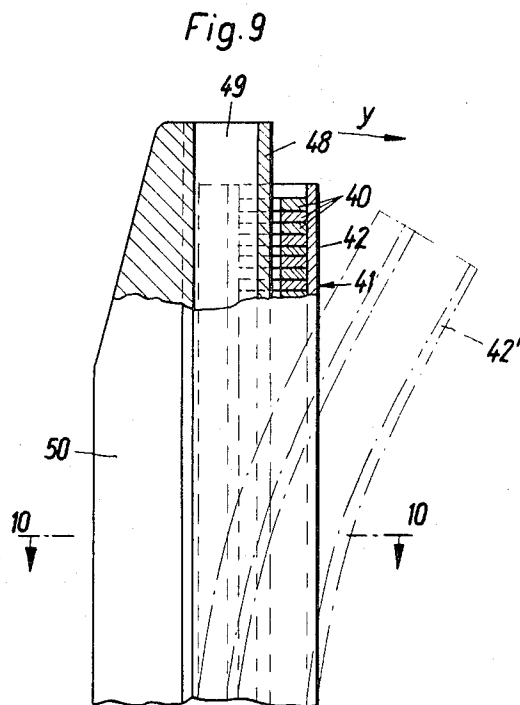
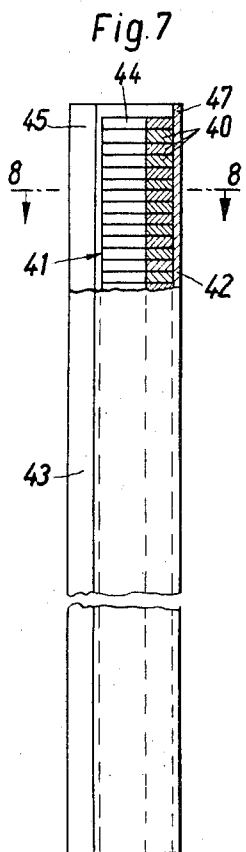

Inventors
Peter Benzing, Richard Klein,
Alfred Trampisch
By Richard *[Signature]*
att

DISPENSER FOR C-WASHERS AND THE LIKE AND WASHER PACKAGE FOR USE WITH DISPENSER

BACKGROUND OF THE INVENTION

This application relates to the handling of C-washers and of similar small, substantially flat elements which extend in an arc about an axial opening, and particularly to a dispenser for C-washers and the like, to a package of washers especially suitable for use with the dispenser, and to a method of making the package.

It is known to arrange lock washers in coaxial alignment on a carrier bar, and to handle and ship the stack of washers so produced together with the carrier bar. The bar with its stack of washers may be inserted into a dispenser which permits the washers to be withdrawn individually from the bar. The carrier bars are returned to the washer manufacturer for reuse.

The carrier bars materially add to the weight of the merchandise to be shipped from the washer manufacturer to the consumer, thereby significantly increasing the cost of the washers, additional cost being incurred by the return of the empty carriers. The stacks of washers on the bars are quite long, and thus inconvenient to handle and to store even if they accommodate only a relatively small number of washers, such as a few thousand.

Among the objects of the instant invention is the provision of a package of washers or similar, relatively small, flat elements in which the elements are held in the necessary alignment by a structure so light as not materially to increase the weight of the washers while in transit, so inexpensive as to be disposable, and of such properties that the package may be shaped so as to occupy a minimum of space while being handled.

SUMMARY OF THE DISCLOSURE

The invention, in one of its aspects, resides in a package including a multiplicity of substantially flat elements, each element having an axis and extending in an arc about the axis, and an envelope which conformingly engages the elements and holds the same loosely superimposed in coaxial alignment, the envelope being elongated in the common direction of the element axes.

The invention also resides in a method of making such a package in which the elements, each defining an axial opening therethrough, are slid over an elongated carrier until the carrier is received in each of the openings and the elements are coaxially mounted on the carrier. The carrier and the elements mounted thereon are thereafter inserted into a loosely fitting, substantially tubular envelope until the envelope is approximately coaxial with the elements, whereupon the envelope is contracted transversely of the common axis of the envelope and of the elements until the envelope conformingly engages each element. The carrier may then be withdrawn from the element openings.

The dispenser of the invention which is employed during use of the above described package preferably has an elongated, substantially straight guide member and is equipped with a cutting blade whose edge is obliquely inclined relative to the direction of elongation of the guide member.

Other features, additional objects, and many of the attendant advantages of this invention will readily be

appreciated as the same becomes better understood by reference to the following detailed description of preferred embodiments when considered in connection with the accompanying drawings.

BRIEF DESCRIPTION OF THE DRAWINGS

In the drawings:

FIG. 1 shows apparatus of the invention for dispensing washers from a package of the same, the view being in side elevation;

FIG. 2 illustrates the apparatus of FIG. 1 in partial side-elevation section on a scale larger than that of FIG. 1;

FIGS. 3 and 4 show the device of FIG. 2 in plan section on the lines 3—3 and 4—4 respectively;

FIG. 5 shows a portion of dispensing apparatus of the invention in side elevation and on the scale of FIG. 2;

FIG. 6 shows a package of the invention together with the top portion of the dispenser of FIG. 1 in side elevation;

FIG. 7 illustrates a modified package of the invention in side-elevation and partly in section;

FIG. 8 illustrates the package of FIG. 7 in section on the line 8—8;

FIG. 9 shows a dispenser for use with the package of FIGS. 7 and 8 in a view corresponding to that of FIG. 2, and in section on the line 9—9 in FIG. 10;

FIG. 10 shows the apparatus of FIG. 9 in section on the line 10—14; and

FIG. 11 illustrates a modification of the apparatus of FIG. 10.

DESCRIPTION OF THE PREFERRED EMBODIMENTS

Referring now to the drawings in detail, and initially to FIGS. 1 to 4, there is seen a loose stack 10 of stirrup-shaped C-washers 11 coaxially superimposed in such a manner that their open sides face in the same direction. The upper portion of the stack 10 is shrink-wrapped in an envelope 12 of pliable polyvinyl chloride tubing. The tubing conformingly engages each washer about its circumference, is partly received in the radial slot of each washer, and also penetrates to a small extent between successive washers in the stack so as to keep them loosely superimposed in coaxial alignment, thereby permitting the flexible package formed by the washers and their envelope to be coiled, for instance into a spiral 13 as shown in FIG. 6.

The dispenser 14 on which individual washers 11 are taken from the package has a base 15 which may be fixedly mounted on a work table, if so desired. An upright column 16 on the base 15 carries a vertical guide rail 19 of T-shaped section, the flange 17 of the rail being connected to the column 16 by a web 18.

The web 18 is partly cut away near the top end of the rail 19, and the flange 17 is cut away near the bottom end of the rail to leave a gap sufficient for passage of a washer 11 between the end of the flange 17 and the top surface 25 of the base 15.

The top end 17a of the flange 17 and the column 16 define an opening into which a cutting blade 20 projects. The straight edge 21 of the blade 20 is obliquely downwardly inclined relative to the guide rail 19, and extends in a common plane with the rail. The blade 20 is fastened in a slot 22a of the column 16 by a screw 22.

23 having a passage 24 therethrough which is vertically aligned with the flange 17 of the guide rail 19. The straight end of the package formed by the washer stack 10 and the envelope 12 extends from the spiral 13 through the passage 24 and over the guide rail 19, the flange 17 of the latter being received in the axial openings of the stacked washers 11, and the web 18 extending outwardly through the aligned radial slots of the washers 11 and an axial slot 27 (FIG. 4) which is cut into the lastic envelope 12 when the package is pushed downward through the passage 24 and over the cutting edge 21 of the blade 20. The slotted envelope 12' thus may be peeled from the stack 10 by moving its lower end as indicated by the arrow x, and cutting it transversely near the bracket 23 as shown at 26.

In the modified dispenser illustrated in FIG. 5, the straightedged blade 20 is replaced by a circular blade 28 rotatably mounted on the column 16 by a pin 29 in such a position that the descending envelope 12 is slotted as it meets an obliquely inclined portion of the circular cutting edge of the blade 28. The bracket 23 carries a depending blade 30 having a horizontal cutting edge 31 which permits an envelope portion 12' to be cut off by bending it upward as indicated by the arrow y after it has been peeled from the stacked washers 11, the washers and the envelope being shown in phantom view in FIG. 5.

In preparing a package of washers 11, the washers are punched from sheet metal and finished as is usual. They are then fed from a hopper through a vibrating feeder in a conventional manner to a straight, rigid carrier bar having the same T-shaped cross section as the guide rail 19 in such a manner that the washers slide over the web of the carrier until the latter is received in the openings of all washers which it is intended to include in the package. The initial length of the package and the number of washers that it is desired to include in the package may be selected at will for reasons which will presently become apparent.

The carrier bar with the stack of washers mounted thereon is thereafter inserted in a loosely fitting tube of shrinkable plastic, such as a tube of shrinkable polyvinyl chloride film. If so desired, the tube may be formed on the stack from flat, shrinkable, plastic foil which is wrapped about the stack until its edges overlap, and by thereafter heat sealing the edges to each other. The heat of the sealing operation may cause the foil to contract and conformingly to engage such washers as described above.

If an extruded or otherwise pre-shaped tube is employed, the carrier bar with the stacked washers is inserted axially into the tube, and the wrapped washers with the carrier are briefly exposed to an ambient temperature of about 150°C. to shrink the tube about the washers. The resulting circumferential and partly axial tension in the plastic material of the tube maintains the desired alignment of the washers, thus permitting the carrier bar to be withdrawn in an axial direction. The axial ends of the stack may be secured by heat sealing opposite walls of a projecting end portion of the plastic envelope to each other or in any other desired manner.

The package so formed is flexible enough to be bent into a spiral or wound on a core to form a spool which occupies but a fraction of the storage space required

for holding an handling the straight length of the package. The coiled package may be shipped in flat cans or other containers, and is gradually unwound and straightened during use. Because of the great number of individual washers accommodated in each package, a new coil need be supplied only at great intervals.

The manner in which the dispensed washers are withdrawn from the free end of the stack 10 along the base surface 25 has not been illustrated in detail. Individual washers may be pulled from the stack by hand or by a simple tool, but a mechanized pusher or gripper arrangement, conventional in this art, may be resorted to.

If so desired, the washer packages may be made straight where relatively few washers are to be combined in a package, and short stacks of washers may be shrink-wrapped in plastic foil by the method outlined above. Another package of the invention, which is particularly convenient with relatively short stacks of washers, is shown in FIGS. 7 and 8.

Stirrup-shaped washers 40 are aligned in a straight stack 41 and are enveloped over more than three quarters of their circumference by a relatively rigid and shape retaining plastic envelope 42 which may consist of polyvinyl chloride containing only a moderate amount of plasticizer. The envelope 42 is also approximately C-shaped in cross section and has an axial slot 45 radially aligned with the radial slots 44 of the several C-washers 40. Edge portions 43 of the envelope 42 extend radially outward from the remainder of the envelope 42 and diverge in a radially outward direction.

As illustrated in FIG. 8, the envelope 42 is under radial stress and engages the washer 40 under its resilient force. In the relaxed condition, the envelope 42 has an internal cross section which is materially smaller than the cross section of each washer 40.

The package is assembled by slipping the washers 40 over a carrier bar 46, shown in phantom view in FIG. 8, and forcing the stack of washers while supported on the carrier bar through the inwardly tapering gap between the edge portions 43 until the envelope 42 snaps over the stack of washers 40, the flange 46a being within the envelope, and the web 46b projecting outwardly through the aligned slots 44, 45. The carrier bar 46 may then be withdrawn in an axial direction from the loosely fitting washers 40, and the ends 47 of the envelope 42 may then be sealed over both ends of the stack 41 as described above.

FIGS. 9 and 10 partly illustrate a dispenser for washer packages of the type illustrated in FIGS. 7 and 8, the portion of the dispenser omitted from the showing of FIG. 9 being substantially identical with the corresponding parts of the dispenser of FIG. 1.

A flange 48 of a guide rail is attached to the upright column 50 of the dispenser by the web 49 of the rail which freely projects through the aligned slots 44, 45 when the package is slipped over the guide rail from the top down. The resilient envelope 42 is then removed by bending it away from the firmly held stack 41 of washers 40 at the top of the stack in the direction of the arrow y as indicated at 42'.

FIG. 11 shows a modified dispenser for somewhat different C-washers in a fragmentary, sectional plan view. Each washer 110 is provided with radial lugs 110a on either side of its radial slot. The stacked

washers are held in aligned position prior to and during installation on the dispenser by an envelope 112 which is a slotted tube provided with a fin or rib 113 diametrically opposite the slot. The guide rail of the dispenser has a head or flange 118 of cylindrical shape slidably matching the internal contour of the washers 110, and attached to a column, not fully shown in FIG. 11, by a thin web 119 which extends outward of the mounted package between the two rows of lugs 110a.

The fin or rib 113 facilitates handling of the envelope 112 during insertion of the washers 110 while the washers are held in alignment on a carrier bar, not itself seen in FIG. 11, and makes it particularly simple to strip the envelope 112 from the stack of washers after the washers are supported on the flange 118. During use, but they are so inexpensive to be disposable without significantly affecting the cost of the washers. They greatly simplify the transportation and use of the washers. The cost of the slotted tube envelopes 42,112 shown in FIGS. 7 to 11 is slightly higher so as to justify their return from the user to the manufacturer of the washers in some instances. Their weight, however, is so small as to reduce transportation cost to a minimum.

It is entirely practical to combine many thousands of washers in a single package of the invention, as shown in FIG. 6, without causing any difficulties in the handling and shipping of the package, which are not inherent in the weight of the washers themselves.

It should be understood, of course, that the foregoing disclosure relates only to a preferred embodiment of the invention, and that it is intended to cover all changes and modifications of the examples of the in-

vention herein chosen for the purpose of the disclosure which do not constitute departures from the spirit and scope of the invention.

We claim:

1. A package comprising a plurality of substantially flat elements, each element having an axis and extending in an arc about said axis, said elements being aligned generally along their axes, a resilient envelope radially contracted over said plurality of elements to conformingly engage each of said elements under circumferential tension to secure each element in alignment about said axis, said envelope having an axial slot and a projection substantially diametrically opposite thereto, said plurality of elements being held in loose axial superimposition to cause said elements to flex along their axes, whereby said elements, together with said envelope, is permitted to assume the shape of a coil while maintaining alignment of each of said elements.

2. A package as set forth in claim 1, wherein said envelope is tubular and consists of shrinkable synthetic resin composition having a cross section in the relaxed condition smaller than the corresponding dimension of said elements.

3. A package as set forth in claim 1, wherein each element is formed with a radial slot so as to be substantially C-shaped, the radial slots of said elements are aligned axially with the slot of said envelope, said envelope having portions extending into and received in the radial slots of the engaged elements.

* * * * *

35

40

45

50

55

60

65