

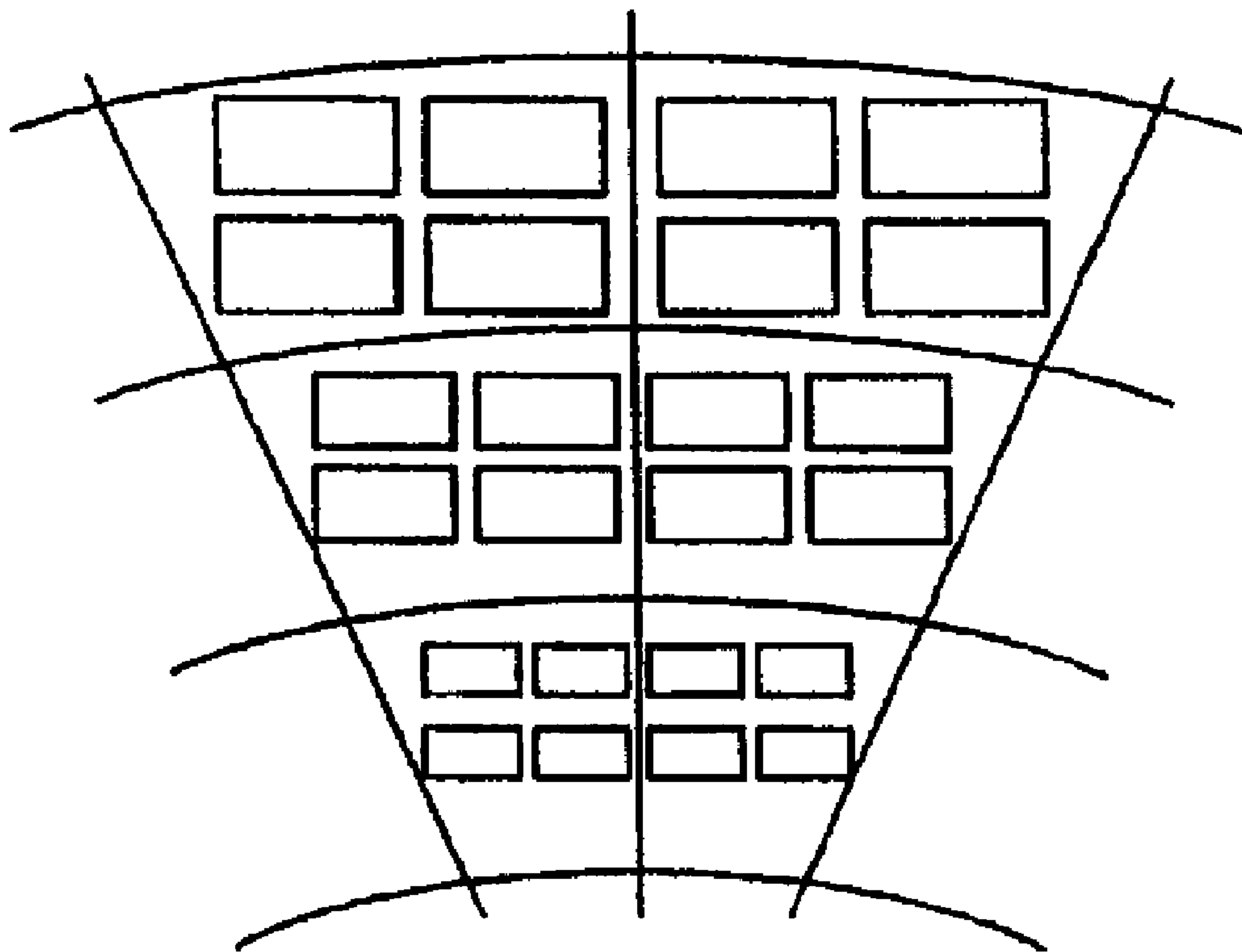

(22) Date de dépôt/Filing Date: 2005/09/13
 (41) Mise à la disp. pub./Open to Public Insp.: 2006/03/27
 (30) Priorités/Priorities: 2004/09/27 (60/613,853) US;
 2005/05/20 (11/134,837) US

(51) Cl.Int./Int.Cl. *G02F 1/01* (2006.01),
G09G 5/00 (2006.01), *G09F 9/30* (2006.01),
G02B 26/00 (2006.01), *B81B 7/02* (2006.01),
G02B 26/08 (2006.01)
 (71) Demandeur/Applicant:
 IDC, LLC, US
 (72) Inventeur/Inventor:
 CHUI, CLARENCE, US
 (74) Agent: SMART & BIGGAR

(54) Titre : PIXELS D'AFFICHAGE REFLECHISSANTS DISPOSES EN RESEAUX NON RECTANGULAIRES
 (54) Title: REFLECTIVE DISPLAY PIXELS ARRANGED IN NON-RECTANGULAR ARRAYS



(57) Abrégé/Abstract:

A display is formed with a plurality of reflective display pixels arranged in a curvilinear configuration, and a plurality of electrodes, where each electrode is electrically coupled to two or more reflective display pixels. In some embodiments, the array is at least partially curvilinear. The reflective display pixels include interferometric modulators.

Abstract

A display is formed with a plurality of reflective display pixels arranged in a curvilinear configuration, and a plurality of electrodes, where each electrode is electrically coupled to two or
5 more reflective display pixels. In some embodiments, the array is at least partially curvilinear. The reflective display pixels include interferometric modulators.

Internal reference: IRDM.092 NON-EP / IDC-040054

REFLECTIVE DISPLAY PIXELS ARRANGED IN NON-RECTANGULAR ARRAYSBackgroundField of the Invention

5 The field of the invention relates to microelectromechanical systems (MEMS). More particularly, this application relates to interferometric display pixels in non-rectangular arrays.

Description of the Related Technology

10 Microelectromechanical systems (MEMS) include micro mechanical elements, actuators, and electronics. Micromechanical elements may be created using deposition, etching, and other micromachining processes that etch away parts of substrates and/or deposited material layers or that add layers to form electrical and electromechanical devices. One type of MEMS device is called an interferometric modulator. As used herein, the term interferometric modulator or interferometric light modulator refers to a device that selectively absorbs and/or reflects light
15 using the principles of optical interference. In certain embodiments, an interferometric modulator may comprise a pair of conductive plates, one or both of which may be transparent and/or reflective in whole or part and capable of relative motion upon application of an appropriate electrical signal. In a particular embodiment, one plate may comprise a stationary layer deposited on a substrate and the other plate may comprise a metallic membrane separated from the
20 stationary layer by an air gap. As described herein in more detail, the position of one plate in relation to another can change the optical interference of light incident on the interferometric modulator. Such devices have a wide range of applications, and it would be beneficial in the art to utilize and/or modify the characteristics of these types of devices so that their features can be exploited in improving existing products and creating new products that have not yet been
25 developed.

Summary of Certain Embodiments

30 The system, method, and devices of the invention each have several aspects, no single one of which is solely responsible for its desirable attributes. Without limiting the scope of this invention, its more prominent features will now be discussed briefly. After considering this discussion, and particularly after reading the section entitled "Detailed Description of Certain Embodiments" one will understand how the features of this invention provide advantages over other display devices.

35 In certain embodiments, an apparatus comprises a display. The display comprises a plurality of interferometric modulators arranged in an at least partially curvilinear configuration.

The display further comprises a plurality of electrodes. Each electrode is electrically coupled to two or more interferometric modulators.

In certain embodiments, a display comprises a plurality of interferometric modulators arranged in an at least partially curvilinear configuration. The display further comprises a first electrode electrically coupled to a first group of interferometric modulators. The display further comprises a second electrode electrically coupled to a second group of interferometric modulators. Each of the first group and the second group of interferometric modulators contains at least one interferometric modulator in common, and contains at least one interferometric modulator not in common.

In certain embodiments, an apparatus comprises a display. The display comprises a plurality of means for interferometrically modulating light. The display further comprises a plurality of means for conducting electricity, wherein each conducting means is electrically coupled to two or more modulating means.

In certain embodiments, a method forms a display device. The method comprises forming a plurality of interferometric modulators on the substrate. The interferometric modulators are arranged in an at least partially curvilinear configuration. The method further comprises forming a plurality of electrodes on the substrate. Each electrode is electrically coupled to two or more interferometric modulators.

In certain embodiments, a method displays an image. The method comprises providing a display comprising a plurality of interferometric modulators arranged in an at least partially curvilinear configuration. The display further comprises a plurality of electrodes. Each electrode is electrically coupled to two or more interferometric modulators. The method further comprises selectively applying signals to the plurality of electrodes to activate selected interferometric modulators of the plurality of interferometric modulators.

In certain embodiments, a display comprises a plurality of interferometric modulators arranged in an at least partially curvilinear configuration. The display further comprises a viewing surface comprising a plurality of regions. Each region comprises an optically active area and an optically inactive area. Each region has a ratio of the optically active area to the optically inactive area. The ratio of any first region larger than a designated surface area is substantially the same as the ratio of any second region of the display larger than the designated area.

In certain embodiments, a display comprises means for interferometrically modulating light arranged in an at least partially curvilinear configuration. The display further comprises means for viewing an image. The viewing means comprises a plurality of regions. Each region comprises an optically active area and an optically inactive area. Each region has a ratio of the optically active area to the optically inactive area. The ratio of any first region larger than a designated surface area is substantially the same as the ratio of any second region of the display larger than the designated area.

In certain embodiments, a method forms a display device. The method comprises forming a plurality of interferometric modulators arranged in an at least partially curvilinear configuration. The method further comprises forming a viewing surface comprising a plurality of regions. Each region comprises an optically active area and an optically inactive area. Each region has a ratio of the optically active area to the optically inactive area. The ratio of any first region larger than a designated surface area is substantially the same as the ratio of any second region of the display larger than the designated area.

In certain embodiments, a method displays an image. The method comprises providing a display comprising a plurality of interferometric modulators arranged in an at least partially curvilinear configuration. The display further comprises a viewing surface comprising a plurality of regions. Each region comprises an optically active area and an optically inactive area. Each region has a ratio of the optically active area to the optically inactive area. The ratio of any first region larger than a designated surface area is substantially the same as the ratio of any second region of the display larger than the designated area. The method further comprises selectively activating selected interferometric modulators of the plurality of interferometric modulators.

In certain embodiments, a display has an at least partially curvilinear edge. The display comprises a plurality of interferometric modulators arranged in an at least partially curvilinear configuration of pixels. The pixels form a boundary, wherein the boundary corresponds to the edge.

In certain embodiments, a display has an at least partially curvilinear edge. The display comprises a plurality of means for interferometrically modulating light arranged in an at least partially curvilinear configuration of pixels. The pixels form a boundary, wherein the boundary corresponds to the edge.

In certain embodiments, a method forms a display device. The method comprises forming a plurality of interferometric modulators arranged in an at least partially curvilinear configuration of pixels. The pixels form a boundary, wherein the boundary corresponds to an at least partially curvilinear edge of the display.

In certain embodiments, a method displays an image. The method comprises providing a display comprising a plurality of interferometric modulators arranged in an at least partially curvilinear configuration of pixels. The pixels form a boundary, wherein the boundary corresponds to an at least partially curvilinear edge of the display. The method further comprises selectively activating selected interferometric modulators of the plurality of interferometric modulators.

Brief Description of the Drawings

Figure 1 is an isometric view depicting a portion of one embodiment of an interferometric modulator display in which a movable reflective layer of a first interferometric modulator is in a

released position and a movable reflective layer of a second interferometric modulator is in an actuated position.

Figure 2 is a system block diagram illustrating one embodiment of an electronic device incorporating a 3x3 interferometric modulator display.

5 Figure 3 is a diagram of movable mirror position versus applied voltage for one exemplary embodiment of an interferometric modulator of Figure 1.

Figure 4 is an illustration of a set of row and column voltages that may be used to drive an interferometric modulator display.

10 Figure 5A illustrates one exemplary frame of display data in the 3x3 interferometric modulator display of Figure 2.

Figure 5B illustrates one exemplary timing diagram for row and column signals that may be used to write the frame of Figure 5A.

Figure 6A is a cross section of the device of Figure 1.

15 Figure 6B is a cross section of an alternative embodiment of an interferometric modulator.

Figure 6C is a cross section of another alternative embodiment of an interferometric modulator.

Figure 7 is a perspective view depicting a wrist watch with an enlarged illustration of a non-rectangular pixel array used on the face thereof.

20 Figure 8 is an illustration of a non-rectangular pixel array in which each pixel has substantially the same area.

Figure 9A is an illustration of a non-rectangular pixel array in which each pixel contains a single interferometric modulator.

25 Figure 9B is an illustration of a non-rectangular pixel array in which each pixel contains four interferometric modulators that are substantially the same shape.

Figure 9C is an illustration of a non-rectangular pixel array in which each pixel contains multiple interferometric modulators that are substantially the same size and substantially the same shape.

Figure 10A is a system block diagram illustrating an embodiment of a display device.

30 Figure 10B is a system block diagram illustrating an embodiment of a display device.

Detailed Description of Certain Embodiments

35 The following detailed description is directed to certain specific embodiments of the invention. However, the invention can be embodied in a multitude of different ways. In this description, reference is made to the drawings wherein like parts are designated with like numerals throughout. As will be apparent from the following description, the embodiments may be implemented in any device that is configured to display an image, whether in motion (e.g.,

video) or stationary (e.g., still image), and whether textual or pictorial. More particularly, it is contemplated that the embodiments may be implemented in or associated with a variety of electronic devices such as, but not limited to, mobile telephones, wireless devices, personal data assistants (PDAs), hand-held or portable computers, GPS receivers/navigators, cameras, MP3
 5 players, camcorders, game consoles, wrist watches, clocks, calculators, television monitors, flat panel displays, computer monitors, auto displays (e.g., odometer display, etc.), cockpit controls and/or displays, display of camera views (e.g., display of a rear view camera in a vehicle), electronic photographs, electronic billboards or signs, projectors, architectural structures, packaging, and aesthetic structures (e.g., display of images on a piece of jewelry). MEMS
 10 devices of similar structure to those described herein can also be used in non-display applications such as in electronic switching devices.

One interferometric modulator display embodiment comprising an interferometric MEMS display element is illustrated in Figure 1. In these devices, the pixels are in either a bright or dark state. In the bright (“on” or “open”) state, the display element reflects a large portion of incident
 15 visible light to a user. When in the dark (“off” or “closed”) state, the display element reflects little incident visible light to the user. Depending on the embodiment, the light reflectance properties of the “on” and “off” states may be reversed. MEMS pixels can be configured to reflect predominantly at selected colors, allowing for a color display in addition to black and white.

Figure 1 is an isometric view depicting two adjacent pixels in a series of pixels of a visual display, wherein each pixel comprises a MEMS interferometric modulator. In some
 20 embodiments, an interferometric modulator display comprises a row/column array of these interferometric modulators. Each interferometric modulator includes a pair of reflective layers positioned at a variable and controllable distance from each other to form a resonant optical cavity with at least one variable dimension. In one embodiment, one of the reflective layers may be
 25 moved between two positions. In the first position, referred to herein as the relaxed, the movable layer is positioned at a relatively large distance from a fixed partially reflective layer. In the second position, the movable layer is positioned more closely adjacent to the partially reflective layer. Incident light that reflects from the two layers interferes constructively or destructively
 30 depending on the position of the movable reflective layer, producing either an overall reflective or non-reflective state for each pixel.

The depicted portion of the pixel array in Figure 1 includes two adjacent interferometric modulators 12a and 12b. In the interferometric modulator 12a on the left, a movable and highly reflective layer 14a is illustrated in a relaxed position at a predetermined distance from a fixed
 35 partially reflective layer 16a. In the interferometric modulator 12b on the right, the movable highly reflective layer 14b is illustrated in an actuated position adjacent to the fixed partially reflective layer 16b.

The fixed layers 16a, 16b are electrically conductive, partially transparent and partially reflective, and may be fabricated, for example, by depositing one or more layers each of chromium and indium-tin-oxide onto a transparent substrate 20. The layers are patterned into parallel strips, and may form row electrodes in a display device as described further below. The
 5 movable layers 14a, 14b may be formed as a series of parallel strips of a deposited metal layer or layers (orthogonal to the row electrodes 16a, 16b) deposited on top of posts 18 and an intervening sacrificial material deposited between the posts 18. When the sacrificial material is etched away, the deformable metal layers 14a, 14b are separated from the fixed metal layers by a defined gap
 10 19. A highly conductive and reflective material such as aluminum may be used for the deformable layers, and these strips may form column electrodes in a display device.

With no applied voltage, the cavity 19 remains between the layers 14a, 16a and the deformable layer is in a mechanically relaxed state as illustrated by the pixel 12a in Figure 1. However, when a potential difference is applied to a selected row and column, the capacitor formed at the intersection of the row and column electrodes at the corresponding pixel becomes
 15 charged, and electrostatic forces pull the electrodes together. If the voltage is high enough, the movable layer is deformed and is forced against the fixed layer (a dielectric material which is not illustrated in this Figure may be deposited on the fixed layer to prevent shorting and control the separation distance) as illustrated by the pixel 12b on the right in Figure 1. The behavior is the same regardless of the polarity of the applied potential difference. In this way, row/column
 20 actuation that can control the reflective vs. non-reflective pixel states is analogous in many ways to that used in conventional LCD and other display technologies.

Figures 2 through 5B illustrate one exemplary process and system for using an array of interferometric modulators in a display application.

Figure 2 is a system block diagram illustrating one embodiment of an electronic device
 25 that may incorporate aspects of the invention. In the exemplary embodiment, the electronic device includes a processor 21 which may be any general purpose single- or multi-chip microprocessor such as an ARM, Pentium[®], Pentium II[®], Pentium III[®], Pentium IV[®], Pentium[®] Pro, an 8051, a MIPS[®], a Power PC[®], an ALPHA[®], or any special purpose microprocessor such as a digital signal processor, microcontroller, or a programmable gate array. As is conventional in
 30 the art, the processor 21 may be configured to execute one or more software modules. In addition to executing an operating system, the processor may be configured to execute one or more software applications, including a web browser, a telephone application, an email program, or any other software application.

In one embodiment, the processor 21 is also configured to communicate with an array
 35 controller 22. In one embodiment, the array controller 22 includes a row driver circuit 24 and a column driver circuit 26 that provide signals to a display array or panel 30. The cross section of the array illustrated in Figure 1 is shown by the lines 1-1 in Figure 2. For MEMS interferometric

modulators, the row/column actuation protocol may take advantage of a hysteresis property of these devices illustrated in Figure 3. It may require, for example, a 10 volt potential difference to cause a movable layer to deform from the relaxed state to the actuated state. However, when the voltage is reduced from that value, the movable layer maintains its state as the voltage drops back below 10 volts. In the exemplary embodiment of Figure 3, the movable layer does not relax completely until the voltage drops below 2 volts. There is thus a range of voltage, about 3 to 7 V in the example illustrated in Figure 3, where there exists a window of applied voltage within which the device is stable in either the relaxed or actuated state. This is referred to herein as the “hysteresis window” or “stability window.” For a display array having the hysteresis characteristics of Figure 3, the row/column actuation protocol can be designed such that during row strobing, pixels in the strobed row that are to be actuated are exposed to a voltage difference of about 10 volts, and pixels that are to be relaxed are exposed to a voltage difference of close to zero volts. After the strobe, the pixels are exposed to a steady state voltage difference of about 5 volts such that they remain in whatever state the row strobe put them in. After being written, each pixel sees a potential difference within the “stability window” of 3-7 volts in this example. This feature makes the pixel design illustrated in Figure 1 stable under the same applied voltage conditions in either an actuated or relaxed pre-existing state. Since each pixel of the interferometric modulator, whether in the actuated or relaxed state, is essentially a capacitor formed by the fixed and moving reflective layers, this stable state can be held at a voltage within the hysteresis window with almost no power dissipation. Essentially no current flows into the pixel if the applied potential is fixed.

In typical applications, a display frame may be created by asserting the set of column electrodes in accordance with the desired set of actuated pixels in the first row. A row pulse is then applied to the row 1 electrode, actuating the pixels corresponding to the asserted column lines. The asserted set of column electrodes is then changed to correspond to the desired set of actuated pixels in the second row. A pulse is then applied to the row 2 electrode, actuating the appropriate pixels in row 2 in accordance with the asserted column electrodes. The row 1 pixels are unaffected by the row 2 pulse, and remain in the state they were set to during the row 1 pulse. This may be repeated for the entire series of rows in a sequential fashion to produce the frame. Generally, the frames are refreshed and/or updated with new display data by continually repeating this process at some desired number of frames per second. A wide variety of protocols for driving row and column electrodes of pixel arrays to produce display frames are also well known and may be used in conjunction with the present invention.

Figures 4, 5A, and 5B illustrate one possible actuation protocol for creating a display frame on the 3x3 array of Figure 2. Figure 4 illustrates a possible set of column and row voltage levels that may be used for pixels exhibiting the hysteresis curves of Figure 3. In the Figure 4 embodiment, actuating a pixel involves setting the appropriate column to $-V_{\text{bias}}$, and the

appropriate row to $+\Delta V$, which may correspond to -5 volts and +5 volts respectively. Relaxing the pixel is accomplished by setting the appropriate column to $+V_{\text{bias}}$, and the appropriate row to the same $+\Delta V$, producing a zero volt potential difference across the pixel. In those rows where the row voltage is held at zero volts, the pixels are stable in whatever state they were originally in, regardless of whether the column is at $+V_{\text{bias}}$, or $-V_{\text{bias}}$. As is also illustrated in Figure 4, it will be appreciated that voltages of opposite polarity than those described above can be used, e.g., actuating a pixel can involve setting the appropriate column to $+V_{\text{bias}}$, and the appropriate row to $-\Delta V$. In this embodiment, releasing the pixel is accomplished by setting the appropriate column to $-V_{\text{bias}}$, and the appropriate row to the same $-\Delta V$, producing a zero volt potential difference across the pixel.

Figure 5B is a timing diagram showing a series of row and column signals applied to the 3x3 array of Figure 2 which will result in the display arrangement illustrated in Figure 5A, where actuated pixels are non-reflective. Prior to writing the frame illustrated in Figure 5A, the pixels can be in any state, and in this example, all the rows are at 0 volts, and all the columns are at +5 volts. With these applied voltages, all pixels are stable in their existing actuated or relaxed states.

In the Figure 5A frame, pixels (1,1), (1,2), (2,2), (3,2) and (3,3) are actuated. To accomplish this, during a "line time" for row 1, columns 1 and 2 are set to -5 volts, and column 3 is set to +5 volts. This does not change the state of any pixels, because all the pixels remain in the 3-7 volt stability window. Row 1 is then strobed with a pulse that goes from 0, up to 5 volts, and back to zero. This actuates the (1,1) and (1,2) pixels and relaxes the (1,3) pixel. No other pixels in the array are affected. To set row 2 as desired, column 2 is set to -5 volts, and columns 1 and 3 are set to +5 volts. The same strobe applied to row 2 will then actuate pixel (2,2) and relax pixels (2,1) and (2,3). Again, no other pixels of the array are affected. Row 3 is similarly set by setting columns 2 and 3 to -5 volts, and column 1 to +5 volts. The row 3 strobe sets the row 3 pixels as shown in Figure 5A. After writing the frame, the row potentials are zero, and the column potentials can remain at either +5 or -5 volts, and the display is then stable in the arrangement of Figure 5A. It will be appreciated that the same procedure can be employed for arrays of dozens or hundreds of rows and columns. It will also be appreciated that the timing, sequence, and levels of voltages used to perform row and column actuation can be varied widely within the general principles outlined above, and the above example is exemplary only, and any actuation voltage method can be used with the systems and methods described herein.

Figures 10A and 10B are system block diagrams illustrating an embodiment of a display device 40. The display device 40 can be, for example, a cellular or mobile telephone. However, the same components of display device 40 or slight variations thereof are also illustrative of various types of display devices such as televisions and portable media players.

The display device 40 includes a housing 41, a display 30, an antenna 43, a speaker 44, an input device 48, and a microphone 46. The housing 41 is generally formed from any of a variety

of manufacturing processes as are well known to those of skill in the art, including injection molding, and vacuum forming. In addition, the housing 41 may be made from any of a variety of materials, including but not limited to plastic, metal, glass, rubber, and ceramic, or a combination thereof. In one embodiment the housing 41 includes removable portions (not shown) that may be
5 interchanged with other removable portions of different color, or containing different logos, pictures, or symbols.

The display 30 of exemplary display device 40 may be any of a variety of displays, including a bi-stable display, as described herein. In other embodiments, the display 30 includes a flat-panel display, such as plasma, EL, OLED, STN LCD, or TFT LCD as described above, or a
10 non-flat-panel display, such as a CRT or other tube device, as is well known to those of skill in the art. However, for purposes of describing the present embodiment, the display 30 includes an interferometric modulator display, as described herein.

The components of one embodiment of exemplary display device 40 are schematically illustrated in Figure 10B. The illustrated exemplary display device 40 includes a housing 41 and
15 can include additional components at least partially enclosed therein. For example, in one embodiment, the exemplary display device 40 includes a network interface 27 that includes an antenna 43 which is coupled to a transceiver 47. The transceiver 47 is connected to a processor 21, which is connected to conditioning hardware 52. The conditioning hardware 52 may be configured to condition a signal (e.g. filter a signal). The conditioning hardware 52 is connected
20 to a speaker 44 and a microphone 46. The processor 21 is also connected to an input device 48 and a driver controller 29. The driver controller 29 is coupled to a frame buffer 28, and to an array controller 22, which in turn is coupled to a display array 30. A power supply 50 provides power to all components as required by the particular exemplary display device 40 design.

The network interface 27 includes the antenna 43 and the transceiver 47 so that the
25 exemplary display device 40 can communicate with one or more devices over a network. In one embodiment the network interface 27 may also have some processing capabilities to relieve requirements of the processor 21. The antenna 43 is any antenna known to those of skill in the art for transmitting and receiving signals. In one embodiment, the antenna transmits and receives RF signals according to the IEEE 802.11 standard, including IEEE 802.11(a), (b), or (g). In another
30 embodiment, the antenna transmits and receives RF signals according to the BLUETOOTH standard. In the case of a cellular telephone, the antenna is designed to receive CDMA, GSM, AMPS or other known signals that are used to communicate within a wireless cell phone network. The transceiver 47 pre-processes the signals received from the antenna 43 so that they may be received by and further manipulated by the processor 21. The transceiver 47 also processes
35 signals received from the processor 21 so that they may be transmitted from the exemplary display device 40 via the antenna 43.

In an alternative embodiment, the transceiver 47 can be replaced by a receiver. In yet another alternative embodiment, network interface 27 can be replaced by an image source, which can store or generate image data to be sent to the processor 21. For example, the image source can be a digital video disc (DVD) or a hard-disc drive that contains image data, or a software
5 module that generates image data.

Processor 21 generally controls the overall operation of the exemplary display device 40. The processor 21 receives data, such as compressed image data from the network interface 27 or an image source, and processes the data into raw image data or into a format that is readily processed into raw image data. The processor 21 then sends the processed data to the driver
10 controller 29 or to frame buffer 28 for storage. Raw data typically refers to the information that identifies the image characteristics at each location within an image. For example, such image characteristics can include color, saturation, and gray-scale level.

In one embodiment, the processor 21 includes a microcontroller, CPU, or logic unit to control operation of the exemplary display device 40. Conditioning hardware 52 generally
15 includes amplifiers and filters for transmitting signals to the speaker 44, and for receiving signals from the microphone 46. Conditioning hardware 52 may be discrete components within the exemplary display device 40, or may be incorporated within the processor 21 or other components.

The driver controller 29 takes the raw image data generated by the processor 21 either
20 directly from the processor 21 or from the frame buffer 28 and reformats the raw image data appropriately for high speed transmission to the array controller 22. Specifically, the driver controller 29 reformats the raw image data into a data flow having a raster-like format, such that it has a time order suitable for scanning across the display array 30. Then the driver controller 29 sends the formatted information to the array controller 22. Although a driver controller 29, such
25 as a LCD controller, is often associated with the system processor 21 as a stand-alone Integrated Circuit (IC), such controllers may be implemented in many ways. They may be embedded in the processor 21 as hardware, embedded in the processor 21 as software, or fully integrated in hardware with the array controller 22.

Typically, the array controller 22 receives the formatted information from the driver
30 controller 29 and reformats the video data into a parallel set of waveforms that are applied many times per second to the hundreds and sometimes thousands of leads coming from the display's x-y matrix of pixels.

In one embodiment, the driver controller 29, array controller 22, and display array 30 are appropriate for any of the types of displays described herein. For example, in one embodiment,
35 driver controller 29 is a conventional display controller or a bi-stable display controller (e.g., an interferometric modulator controller). In another embodiment, array controller 22 is a conventional driver or a bi-stable display driver (e.g., an interferometric modulator display). In

one embodiment, a driver controller 29 is integrated with the array controller 22. Such an embodiment is common in highly integrated systems such as cellular phones, watches, and other small area displays. In yet another embodiment, display array 30 is a typical display array or a bi-stable display array (e.g., a display including an array of interferometric modulators).

5 The input device 48 allows a user to control the operation of the exemplary display device 40. In one embodiment, input device 48 includes a keypad, such as a QWERTY keyboard or a telephone keypad, a button, a switch, a touch-sensitive screen, a pressure- or heat-sensitive membrane. In one embodiment, the microphone 46 is an input device for the exemplary display device 40. When the microphone 46 is used to input data to the device, voice commands may be
10 provided by a user for controlling operations of the exemplary display device 40.

Power supply 50 can include a variety of energy storage devices as are well known in the art. For example, in one embodiment, power supply 50 is a rechargeable battery, such as a nickel-cadmium battery or a lithium ion battery. In another embodiment, power supply 50 is a renewable energy source, a capacitor, or a solar cell, including a plastic solar cell, and solar-cell
15 paint. In another embodiment, power supply 50 is configured to receive power from a wall outlet.

In some implementations control programmability resides, as described above, in a driver controller which can be located in several places in the electronic display system. In some cases control programmability resides in the array controller 22. Those of skill in the art will recognize that the above-described optimization may be implemented in any number of hardware and/or
20 software components and in various configurations.

The details of the structure of interferometric modulators that operate in accordance with the principles set forth above may vary widely. For example, Figures 6A-6C illustrate three different embodiments of the moving mirror structure. Figure 6A is a cross section of the embodiment of Figure 1, where a strip of metal material 14 is deposited on orthogonally
25 extending supports 18. In Figure 6B, the moveable reflective material 14 is attached to supports at the corners only, on tethers 32. In Figure 6C, the moveable reflective material 14 is suspended from a deformable layer 34. This embodiment has benefits because the structural design and materials used for the reflective material 14 can be optimized with respect to the optical properties, and the structural design and materials used for the deformable layer 34 can be
30 optimized with respect to desired mechanical properties. The production of various types of interferometric devices is described in a variety of published documents, including, for example, U.S. Published Application 2004/0051929. A wide variety of known techniques may be used to produce the above described structures involving a series of material deposition, patterning, and etching steps.

35 Many displays, such as computer monitors, televisions, and displays for cell phones, calculators, and PDA's are rectangular. There are some display applications, a watch face, for example, where the display is not rectangular. The usual procedure for making these non –

rectangular displays is to form a rectangular display, and then remove or cover the corners, as necessary. Part of the reason for exclusively rectangular displays is that many display element technologies, such as, for example that used in active matrix LCD's, require complex driving and addressing circuitry. Because the circuitry would have to match or at least compensate for
 5 irregular display geometries, only recti-linear geometries have been preferred. It can be appreciated that this can be a waste of material and thus an aspect of device cost that would be beneficial to eliminate. Additionally, aesthetic sacrifices are made at least at the perimeter when using a square display in a round application.

As described more fully below, interferometric modulators such as those described above
 10 are very suitable for the production of non-rectangular arrays of pixels. As discussed in reference to Figure 1, an interferometric light modulating cavity is formed at the intersections of movable layer columns 14a and 14b, and electrode rows 16a and 16b. Because of less complex driving and addressing circuitry, display arrays comprising interferometric modulators described herein are not constrained to have linear rows and columns. When the general structure shown in Figure
 15 1 is maintained, each movable layer column will be modulated by an electrode row intersecting it, at the intersection, regardless of the local or general shape of the rows or columns. Such modulation will happen as discussed above in reference to Figures 5A and 5B. Accordingly, interferometric modulators may be formed according to the principles taught above having curvilinear shapes. This characteristic of interferometric modulators enables creation of display
 20 arrays in a wide variety of configurations.

Figure 7 shows a wristwatch 700 having a non-rectangular display, a portion of which is shown enlarged as display portion 702. In this embodiment the array is comprised of movable layer columns 714 and curvilinear electrode rows 716, wherein interferometric modulators are formed at row and column intersections. Although in this embodiment electrode rows 716 and
 25 movable layer columns 714 are discussed, it is understood that selection of row and column designation is arbitrary, and that either rows or columns can be formed by the interferometric modulator electrode or movable layer structures. It is further understood that the movable layer, despite being referred to as "movable layer" to distinguish it from the structure referred to as "electrode," is, in fact, an electrode. It is still further understood that rows and columns may be
 30 linear or nonlinear or curvilinear.

In Figure 7, rows 716 are shown as a series of concentric arcs, and the linear columns 714 extend radially from a common center point. The center point of the columns in the embodiment of Figure 7 is shared with a center point of the concentric arcs. And, as discussed above, interferometric modulator pixels are formed at the row 716 and column 714 intersections.

35 In some embodiments rows 716 and columns 714 may be concentric arcs or circles, or they may have different centers. They may have substantially identical or may have different amounts of curvature. They may be partially or wholly linear. They may curve in one or in

multiple directions. They may have substantially the same or different widths. The width of a row 716 or column 714 may change along its length according to or not according to an amount of local curvature. Rows 716 and columns 714 may have substantially the same or differing curvature characteristics. Adjacent rows 716 or adjacent columns 714 may or may not appear substantially parallel. One portion of the display may have curvature characteristics which are substantially the same or different than another portion of the display. One portion of the display may not share a row 716 or column 714 or either with another portion of the display. The curvature of rows 716 and columns 714 may correspond to an overall shape of the entire display, or a portion thereof, or the shape of some other portion of the device comprising the display. The rows 716 and columns 714 may intersect at a range of angles ranging from substantially right angles to very acute angles. Such characteristics of rows 716 and columns 714 as curvature, angles, and widths may be manipulated to achieve a desired aesthetic result. A display may contain rows 716 and columns 714, or may contain only rows 716 or columns 714. Rows 716 and columns 714 may appear to intersect themselves, or to be continuous, having no end point. Electrical connections for the rows 716 and columns 714 may be made with vias to lower layers of the electronics. Such connections may occur singly or multiply, and may be formed at the end or not at the end of the rows 716 and columns 714.

As the pixels are formed by intersections of rows 716 and columns 714, the shapes of pixels will vary with the characteristics of rows 716 and columns 714. Pixels may have straight and/or curved edges. They may be of substantially the same size and/or shape or may have different sizes and shapes. Some pixels may be triangular.

In the embodiment of Figure 7, the rows 716 in the array are substantially equally spaced, resulting in all pixels having the same length along their column edges. As the rows 716 decrease in length toward the center, the width of the pixels along the row edges decreases, resulting in a decrease in the area of the pixels toward the center of the array. Thus, Figure 7 demonstrates one particular embodiment in which the area of different pixels in the array can vary. Additional configurations of the arrays can permit the area of the pixels to vary as desired. For example, varying the width of columns 714 in Figure 7 also results in pixels that vary in area.

Also contemplated herein are embodiments in which most or all of the pixels in the array can have substantially the same area. Figure 8 shows a portion of such an embodiment. By necessity, the columns 814 narrow as they approach the center. To compensate, the rows 816 widen, thereby keeping the area substantially constant throughout the array. Some pixels may also be formed to have a larger or smaller area than the majority of the pixels of the array. For example, in Figure 8, the pixels nearest the center may be made smaller (e.g., divided in half) or larger (e.g., two united into one), while the remainder of the pixels in the array can be configured to have substantially the same area.

In some embodiments, pixels may consist of one interferometric modulator. In such instances, the shape and size of the pixel is the same as the shape and size of the interferometric modulator, as shown in Figure 9A. In other examples, a pixel can contain multiple interferometric modulators, as shown in Figures 9B and 9C. An interferometric modulator can be
5 formed in any selected shape (e.g., circular, oval, etc.) and size, according to the shape and size of the pixel desired, subject only to the state of manufacturing capabilities at the time of fabrication.

Figure 9B shows an example of multiple interferometric modulators within pixels of an array, where the number of interferometric modulators within each pixel is the same for multiple pixels in the array. To realize different sized pixels, different sized interferometric modulators are
10 used. Figure 9C shows an example of an array of pixels where the size of the interferometric modulators within each pixel is the same. To realize different sized pixels, more or fewer interferometric modulators are used. These embodiments are representative of a variety of configurations that can be designed by one skilled in the art.

The shape and size of interferometric modulators to be used in any particular embodiment
15 can be selected according to the principles discussed herein, and principles known in the art, where the knowledge of one skilled in the art includes subject matter covered in U.S. Pat. Nos. 6,794,119, 6,741,377, 6,710,908 and 5,835,255. Design considerations include, but are not limited to the fabrication process of the interferometric modulators, the process for actuating the interferometric modulators, and desired properties of the display such as density of active area,
20 brightness, size and shape.

Displays containing interferometric modulators discussed herein contain an optically active portion, of which the optical properties can be modified in response to signals applied to the interferometric modulators. The displays also contain an optically inactive portion of which the optical properties are not modified in response to signals applied to the interferometric
25 modulators. Typically, most of or the entire inactive portion is the portion separating the interferometric modulators.

In some circumstances it is useful to compare various regions of a viewing area of a display, where regions of the display are any part of the display that contains a sufficient number of pixels so as to represent a generalized density of interferometric modulators. For example, a
30 region must not be so small that it includes only the inactive area separating two interferometric modulators. Typically, a region includes at least four interferometric modulators, but can include any larger number of interferometric modulators, such as 100, 1000 or 10,000 interferometric modulators. The region also can be measured in terms of area, where a region is typically at least 0.0025 mm^2 , but can be larger, such as 0.1 mm^2 , 1 mm^2 , or 10 mm^2 .

35 In some embodiments displays may be configured such that any region of the display having a sufficient area (e.g., as discussed above) has an area ratio of the active portion to inactive portion that is substantially the same as the area ratio of the active portion to inactive portion for

any other region of the display having a sufficient area. Thus, in such embodiments, the area ratio of the active portion to inactive portion is substantially uniform throughout the entire surface of the display. The actual area ratio of the active portion to inactive portion of the displays discussed herein can be any of a broad variety of values, according to the desired appearance of the display.

5 In many embodiments, the amount of active area is maximized.

In other embodiments, when a display with properties other than uniform area ratio of the active portion to inactive portion, is desired, such a display can be designed in accordance with the teachings discussed herein for ordering pixels in a non-rectangular array and for arranging interferometric modulators within those pixels. For example, for circular displays in which the
10 outer portion is desired to have a greater area ratio of the active portion to inactive portion, a design such as that shown in Figure 7 may be used. The pixel size in this embodiment increases at the outer regions of the display. The principles described herein also can be used to create a display in which the inner portion of a circle has a greater area ratio of the active portion to inactive portion, or any of a variety of different configurations according to the desired shape and
15 appearance of the display.

The embodiments discussed herein are those presently preferred and are described so that an understanding of the present invention can be gained. There are, however, many configurations of non-rectangular arrays containing interferometric modulators not specifically described herein but in which the present invention is embodied. The invention should therefore
20 not be seen as limited to the particular embodiments described herein, but rather, it is understood that the present invention has wide applicability with respect to non-rectangular arrays containing interferometric modulators. The invention may be embodied within a form that does not provide all of the features and benefits set forth herein, as some features may be used or practiced separately from others. All modifications, variations, or equivalent arrangements and
25 implementations that are within the scope of the attached claims should therefore be considered within the scope of the invention.

WHAT IS CLAIMED IS:

1. An apparatus comprising:
a plurality of interferometric modulators arranged in an at least partially curvilinear configuration; and
a plurality of electrodes, wherein each electrode is electrically coupled to at least two of the plurality of interferometric modulators.
2. The apparatus of Claim 1, wherein the interferometric modulators of the plurality of interferometric modulators are arranged along arc segments generally parallel to one another.
3. The apparatus of Claim 2, wherein the arc segments are concentric circular segments.
4. The apparatus of Claim 2, wherein at least some of the plurality of interferometric modulators are further arranged along straight lines generally perpendicular to the arc segments.
5. The apparatus of Claim 4, wherein the straight lines are generally non-parallel to one another.
6. The apparatus of Claim 1, wherein at least one interferometric modulator has a generally rectangular shape.
7. The apparatus of Claim 1, wherein at least one interferometric modulator has one or more substantially straight edges.
8. The apparatus of Claim 1, wherein each interferometric modulator has substantially the same area.
9. The apparatus of Claim 1, wherein each interferometric modulator has substantially the same shape.
10. The apparatus of Claim 1, wherein a viewing surface of the apparatus comprises a plurality of regions, each region comprising an optically active area and an optically inactive area, each region having a ratio of the optically active area to the optically inactive area, wherein the ratio of any first region larger than a designated surface area is substantially the same as the ratio of any second region larger than the designated area.
11. The apparatus of Claim 10, wherein the designated area is between about 0.01mm^2 and about 1mm^2 .
12. The apparatus of Claim 1, wherein a viewing surface of the apparatus comprises a plurality of regions, each region comprising an optically active area and an optically inactive area, each region having a ratio of the optically active area to the optically inactive area, wherein the ratio of a first region larger than a designated surface area is different than the ratio of a second region larger than the designated area.

13. The apparatus of Claim 1, further comprising:
 - a processor that is in electrical communication with the plurality of electrodes, the processor being configured to process image data; and
 - a memory device in electrical communication with the processor.
14. The apparatus of Claim 13, further comprising:
 - a driver circuit configured to send at least one signal to the plurality of electrodes.
15. The apparatus of Claim 14, further comprising:
 - a controller configured to send at least a portion of the image data to the driver circuit.
16. The apparatus of Claim 13, further comprising an image source module configured to send the image data to the processor.
17. The apparatus of Claim 16, wherein the image source module comprises at least one of a receiver, transceiver, and transmitter.
18. The apparatus of Claim 13, further comprising an input device configured to receive input data and to communicate the input data to the processor.
19. A display comprising:
 - a plurality of interferometric modulators arranged in an at least partially curvilinear configuration;
 - a first electrode electrically coupled to a first group of interferometric modulators;
 - and
 - a second electrode electrically coupled to a second group of interferometric modulators, and wherein each of the first group and the second group of interferometric modulators contains at least one interferometric modulator in common, and contains at least one interferometric modulator not in common.
20. The display of Claim 19, wherein at least some of the plurality of interferometric modulators are arranged along straight lines.
21. The display of Claim 19, wherein at least one interferometric modulator has one or more substantially straight edges.
22. The display of Claim 19, wherein each interferometric modulator has substantially the same area.
23. The display of Claim 19, wherein each interferometric modulator has substantially the same shape.
24. The display of Claim 19, wherein a viewing surface of the display comprises a plurality of regions, each region comprising an optically active area and an optically inactive area, each region having a ratio of the optically active area to the optically inactive area, wherein the ratio of any first region larger than a designated surface area is substantially the same as the ratio of any second region larger than the designated area.

25. An apparatus comprising a display, wherein the display comprises:
a plurality of means for interferometrically modulating light; and
a plurality of means for conducting electricity, wherein each conducting means is electrically coupled to two or more modulating means.
26. The apparatus of Claim 25, wherein the plurality of modulating means comprises a plurality of interferometric modulators.
27. The apparatus of Claim 25, wherein the plurality of conducting means comprises a plurality of electrodes.
28. A method of forming a display device, the method comprising:
forming a plurality of interferometric modulators on a substrate, the interferometric modulators being arranged in an at least partially curvilinear configuration; and
forming a plurality of electrodes on the substrate, wherein each electrode is electrically coupled to two or more interferometric modulators.
29. The method of Claim 28, wherein each interferometric modulator has substantially the same area.
30. The method of Claim 28, further comprising forming a viewing surface of the display device comprising a plurality of regions, each region comprising an optically active area and an optically inactive area, each region having a ratio of the optically active area to the optically inactive area, wherein the ratio of any first region larger than a designated surface area is substantially the same as the ratio of any second region larger than the designated area.
31. The method of Claim 28, further comprising forming at least one interferometric modulator having one or more substantially straight edges.
32. The method of Claim 28, further comprising forming each interferometric modulator having substantially the same shape.
33. A display device formed by the method of Claim 28.
34. A method of displaying an image, the method comprising:
providing a display comprising a plurality of interferometric modulators arranged in an at least partially curvilinear configuration, the display further comprising a plurality of electrodes, wherein each electrode is electrically coupled to two or more interferometric modulators; and
selectively applying signals to the plurality of electrodes to activate selected interferometric modulators of the plurality of interferometric modulators.
35. A display comprising:
a plurality of interferometric modulators arranged in an at least partially curvilinear configuration; and

a viewing surface comprising a plurality of regions, each region comprising an optically active area and an optically inactive area, each region having a ratio of the optically active area to the optically inactive area, wherein the ratio of any first region larger than a designated surface area is substantially the same as the ratio of any second region of the display larger than the designated area.

36. The display of Claim 35, wherein at least one interferometric modulator has one or more substantially straight edges.

37. The display of Claim 35, wherein each interferometric modulator has substantially the same area.

38. The display of Claim 35, wherein each interferometric modulator has substantially the same shape.

39. The display of Claim 35, further comprising:

a processor that is in electrical communication with said plurality of interferometric modulators, the processor being configured to process image data; and

a memory device in electrical communication with the processor.

40. The display of Claim 39, further comprising:

a driver circuit configured to send at least one signal to said plurality of interferometric modulators.

41. The display of Claim 40, further comprising:

a controller configured to send at least a portion of the image data to the driver circuit.

42. The display of Claim 39, further comprising an image source module configured to send the image data to the processor.

43. The display of Claim 42, wherein the image source module comprises at least one of a receiver, transceiver, and transmitter.

44. The display of Claim 39, further comprising an input device configured to receive input data and to communicate the input data to the processor.

45. A display comprising:

means for interferometrically modulating light arranged in an at least partially curvilinear configuration; and

means for viewing an image, the viewing means comprising a plurality of regions, each region comprising an optically active area and an optically inactive area, each region having a ratio of the optically active area to the optically inactive area, wherein the ratio of any first region larger than a designated surface area is substantially the same as the ratio of any second region of the display larger than the designated area.

46. The display of Claim 45, wherein the modulating means comprises a plurality of interferometric modulators.

47. The display of Claim 45, wherein the viewing means comprises a surface.
48. A method of forming a display device, the method comprising:
forming a plurality of interferometric modulators arranged in an at least partially curvilinear configuration; and
forming a viewing surface comprising a plurality of regions, each region comprising an optically active area and an optically inactive area, each region having a ratio of the optically active area to the optically inactive area, wherein the ratio of any first region larger than a designated surface area is substantially the same as the ratio of any second region of the display larger than the designated area.
49. A display device formed by the method of Claim 48.
50. A method of displaying an image, the method comprising:
providing a display comprising a plurality of interferometric modulators arranged in an at least partially curvilinear configuration, the display further comprising a viewing surface comprising a plurality of regions, each region comprising an optically active area and an optically inactive area, each region having a ratio of the optically active area to the optically inactive area, wherein the ratio of any first region larger than a designated surface area is substantially the same as the ratio of any second region of the display larger than the designated area; and
selectively activating selected interferometric modulators of the plurality of interferometric modulators.
51. A display having an at least partially curvilinear edge, the display comprising a plurality of interferometric modulators arranged in an at least partially curvilinear configuration of pixels, the pixels forming a boundary, wherein the boundary corresponds to the edge.
52. The display of Claim 51, wherein at least one interferometric modulator has one or more substantially straight edges.
53. The display of Claim 51, wherein each interferometric modulator has substantially the same area.
54. The display of Claim 51, wherein each interferometric modulator has substantially the same shape.
55. The display of Claim 51 further comprising a viewing surface having a plurality of regions, each region comprising an optically active area and an optically inactive area, each region having a ratio of the optically active area to the optically inactive area, wherein the ratio of any first region larger than a designated surface area is substantially the same as the ratio of any second region larger than the designated area.

56. The display of Claim 51, further comprising:
a processor that is in electrical communication with the plurality of interferometric modulators, the processor being configured to process image data; and
a memory device in electrical communication with the processor.
57. The display of Claim 56, further comprising:
a driver circuit configured to send at least one signal to the plurality of interferometric modulators.
58. The display of Claim 57, further comprising:
a controller configured to send at least a portion of the image data to the driver circuit.
59. The display of Claim 56, further comprising an image source module configured to send the image data to the processor.
60. The display of Claim 59, wherein the image source module comprises at least one of a receiver, transceiver, and transmitter.
61. The display of Claim 56, further comprising an input device configured to receive input data and to communicate the input data to the processor.
62. A display having an at least partially curvilinear edge, the display comprising a plurality of means for interferometrically modulating light arranged in an at least partially curvilinear configuration of pixels, the pixels forming a boundary, wherein the boundary corresponds to the edge.
63. The display of Claim 62, wherein the plurality of modulating means comprises a plurality of interferometric modulators.
64. A method of forming a display device, the method comprising forming a plurality of interferometric modulators arranged in an at least partially curvilinear configuration of pixels, the pixels forming a boundary, wherein the boundary corresponds to an at least partially curvilinear edge of the display.
65. A display device formed by the method of Claim 64.
66. A method of displaying an image, the method comprising:
providing a display comprising a plurality of interferometric modulators arranged in an at least partially curvilinear configuration of pixels, the pixels forming a boundary, wherein the boundary corresponds to an at least partially curvilinear edge of the display;
and
selectively activating selected interferometric modulators of the plurality of interferometric modulators.

Smart & Biggar
Ottawa, Canada
Patent Agents

1/9

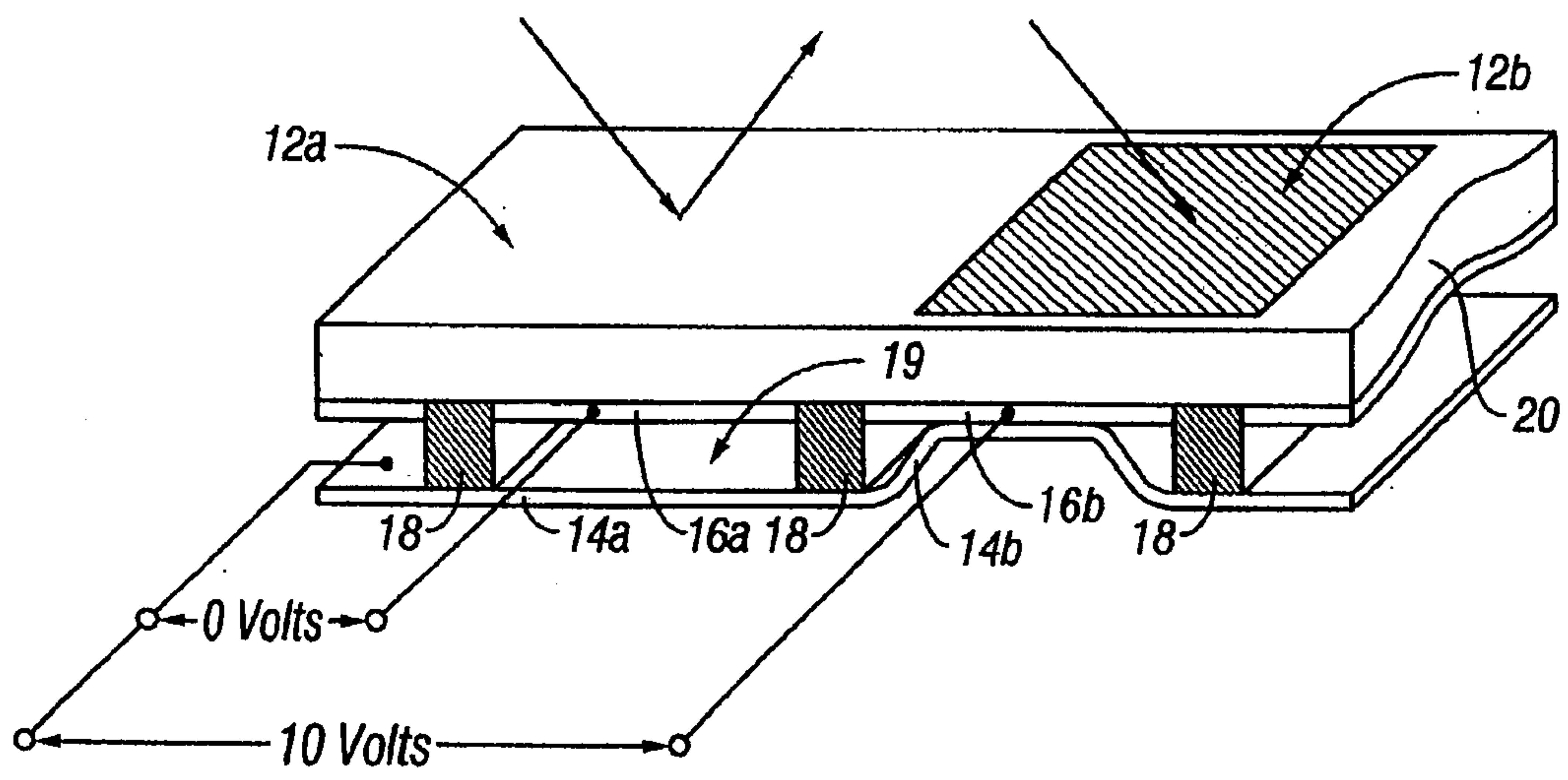

FIG. 1

2/9

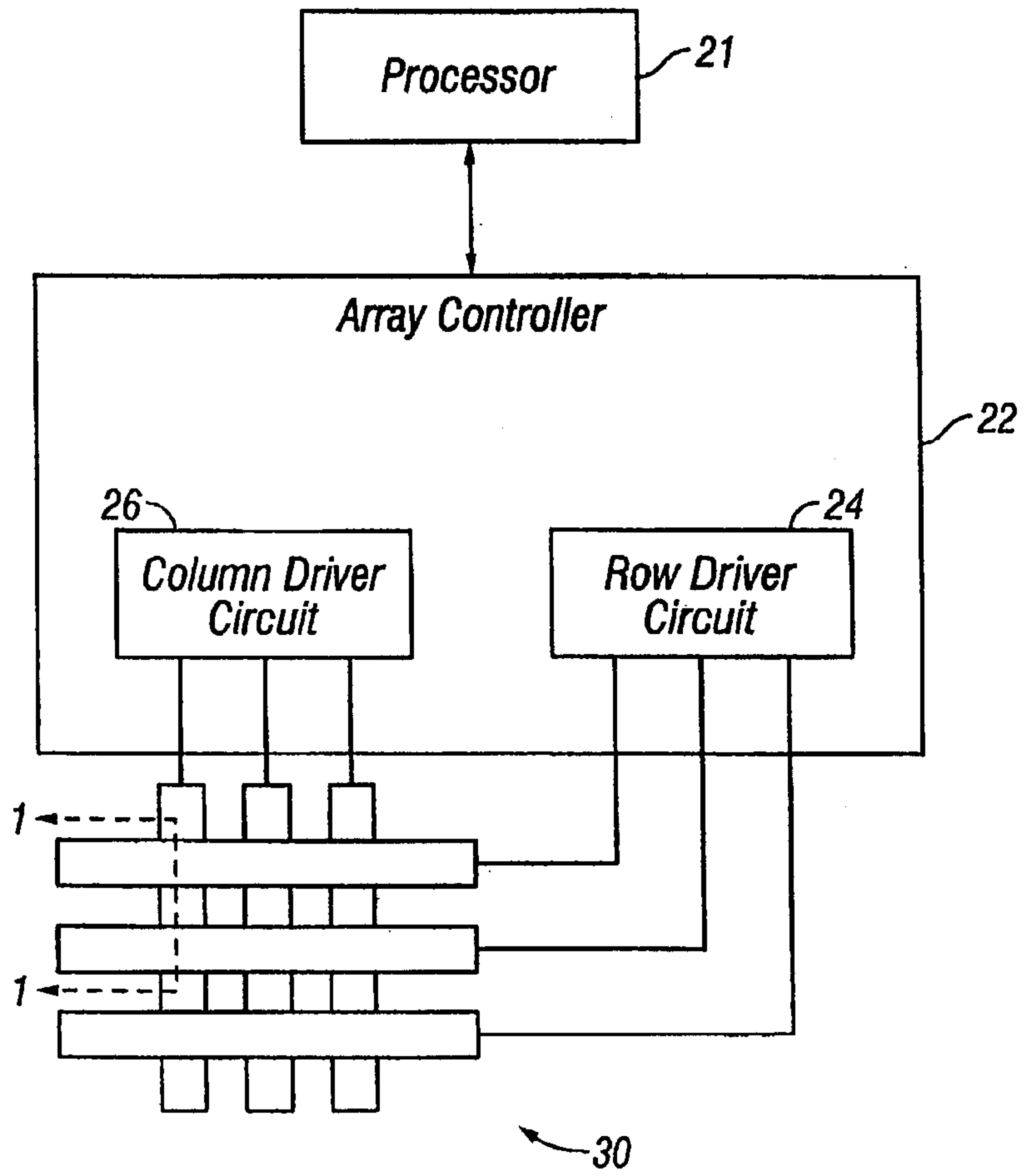

FIG. 2

3/9

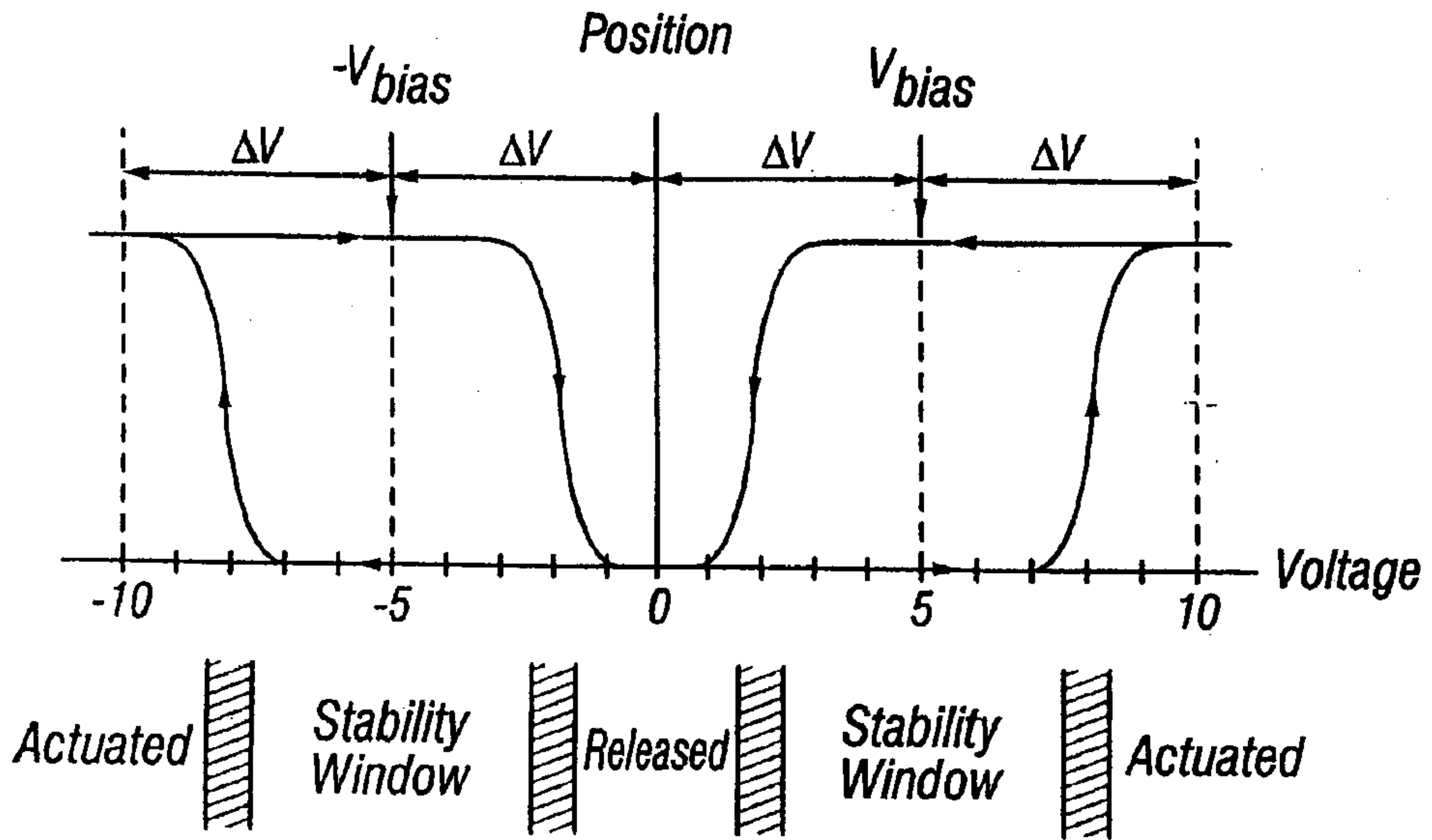

FIG. 3

		Column Output Signals	
		$+V_{bias}$	$-V_{bias}$
Row Output Signals	0	Stable	Stable
	$+\Delta V$	Release	Actuate
	$-\Delta V$	Actuate	Release

FIG. 4

4/9

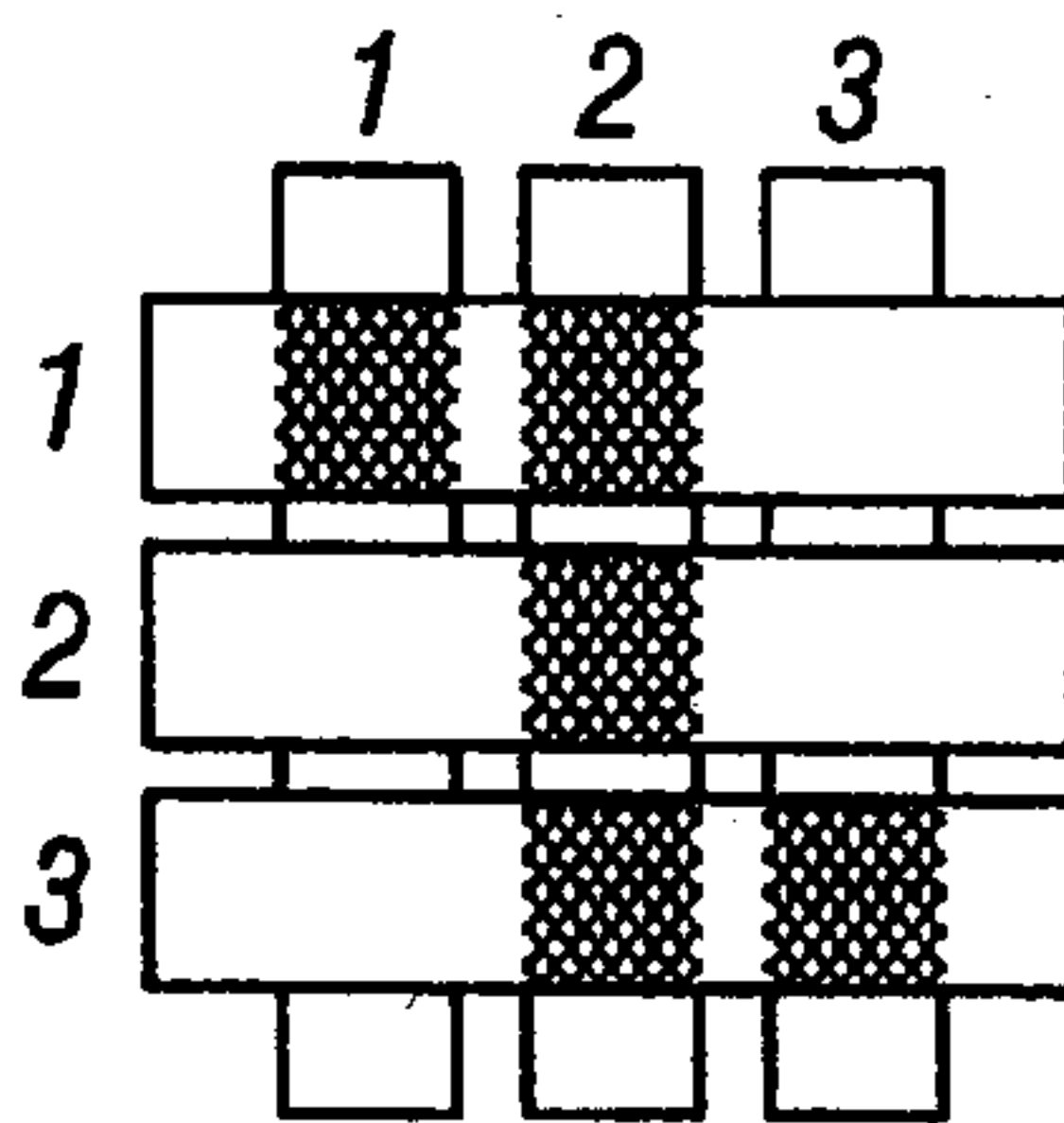

FIG. 5A

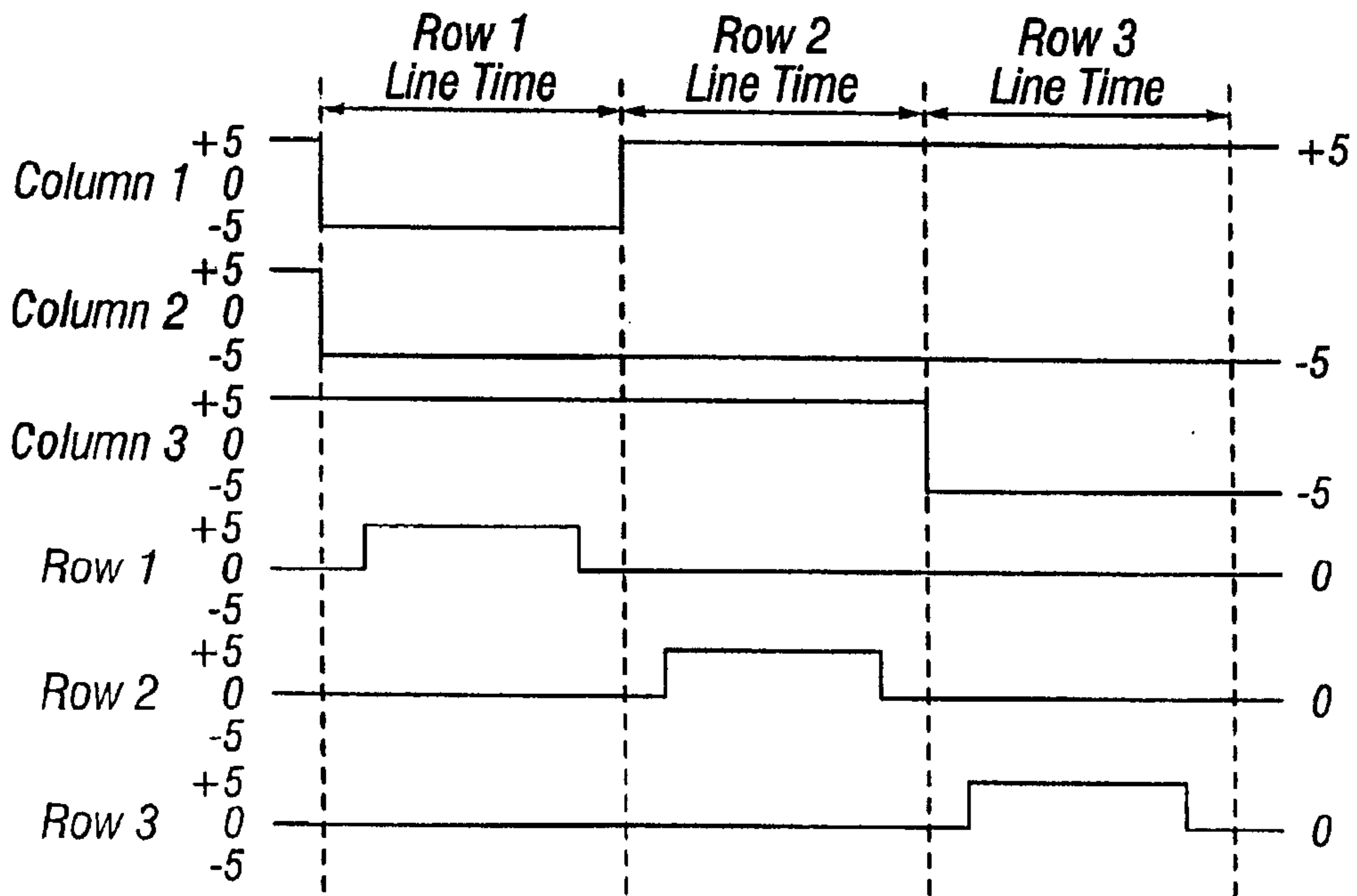

FIG. 5B

5/9

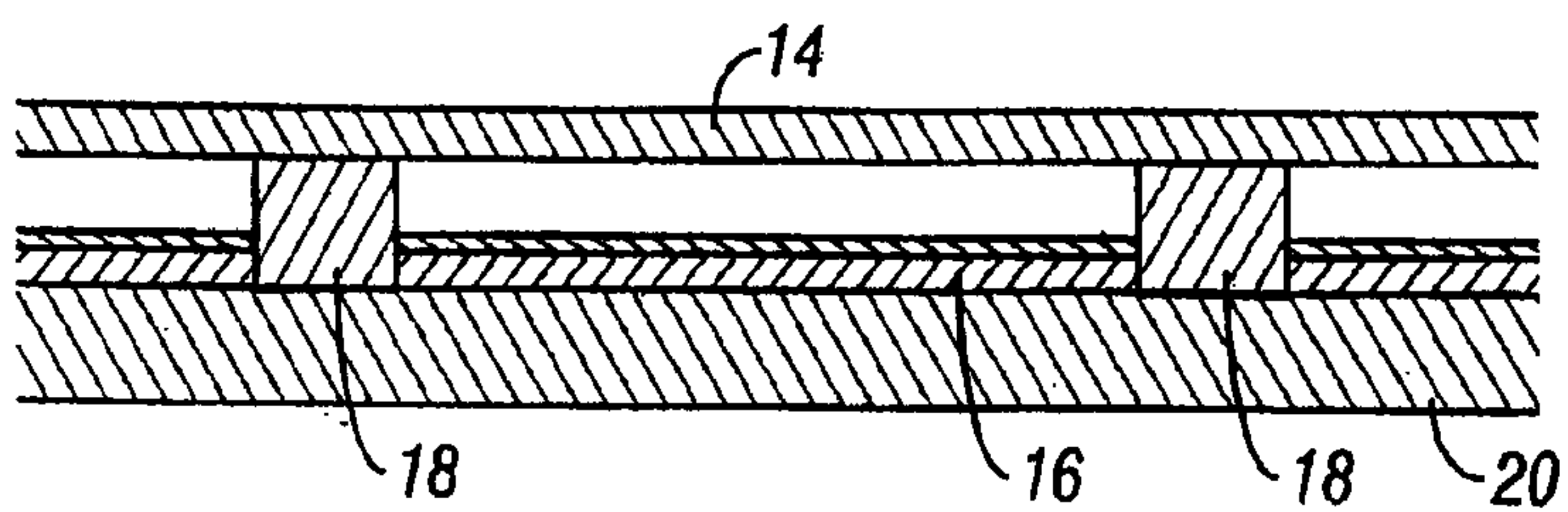

FIG. 6A

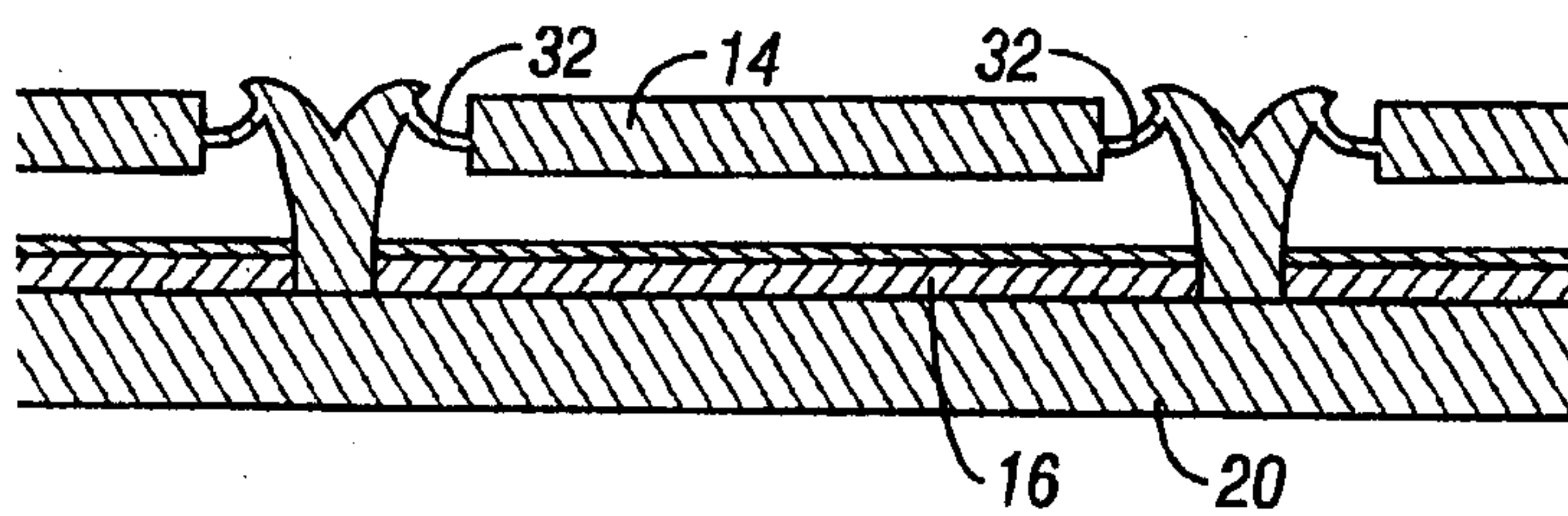

FIG. 6B

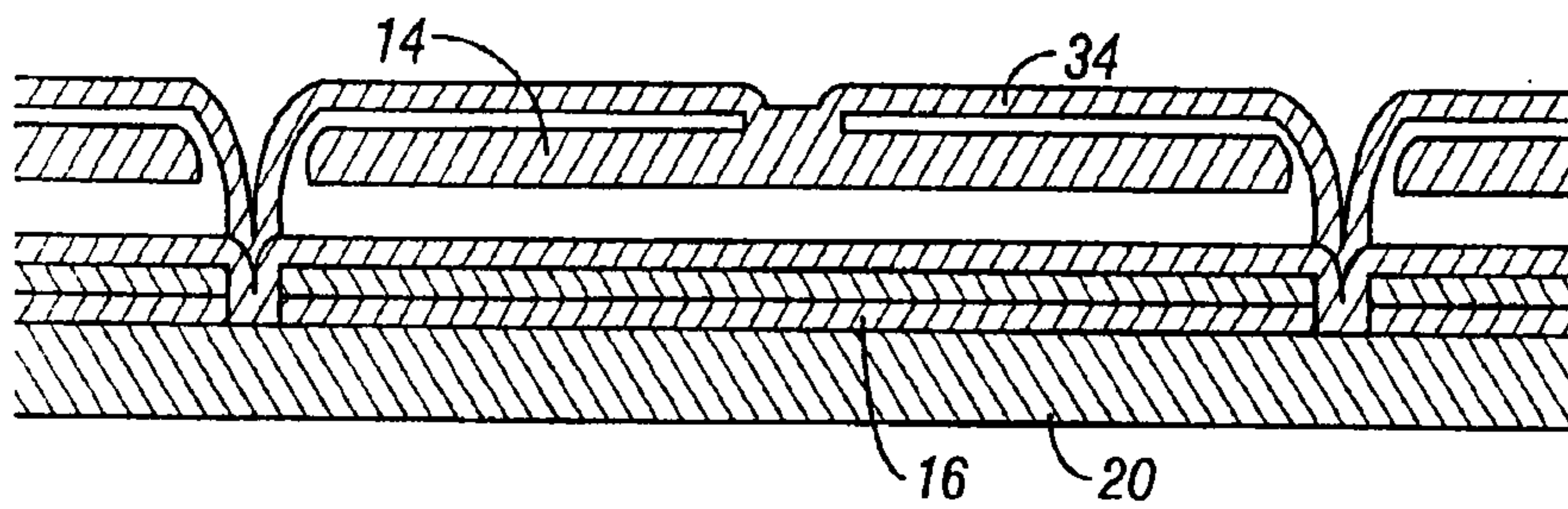

FIG. 6C

6/9

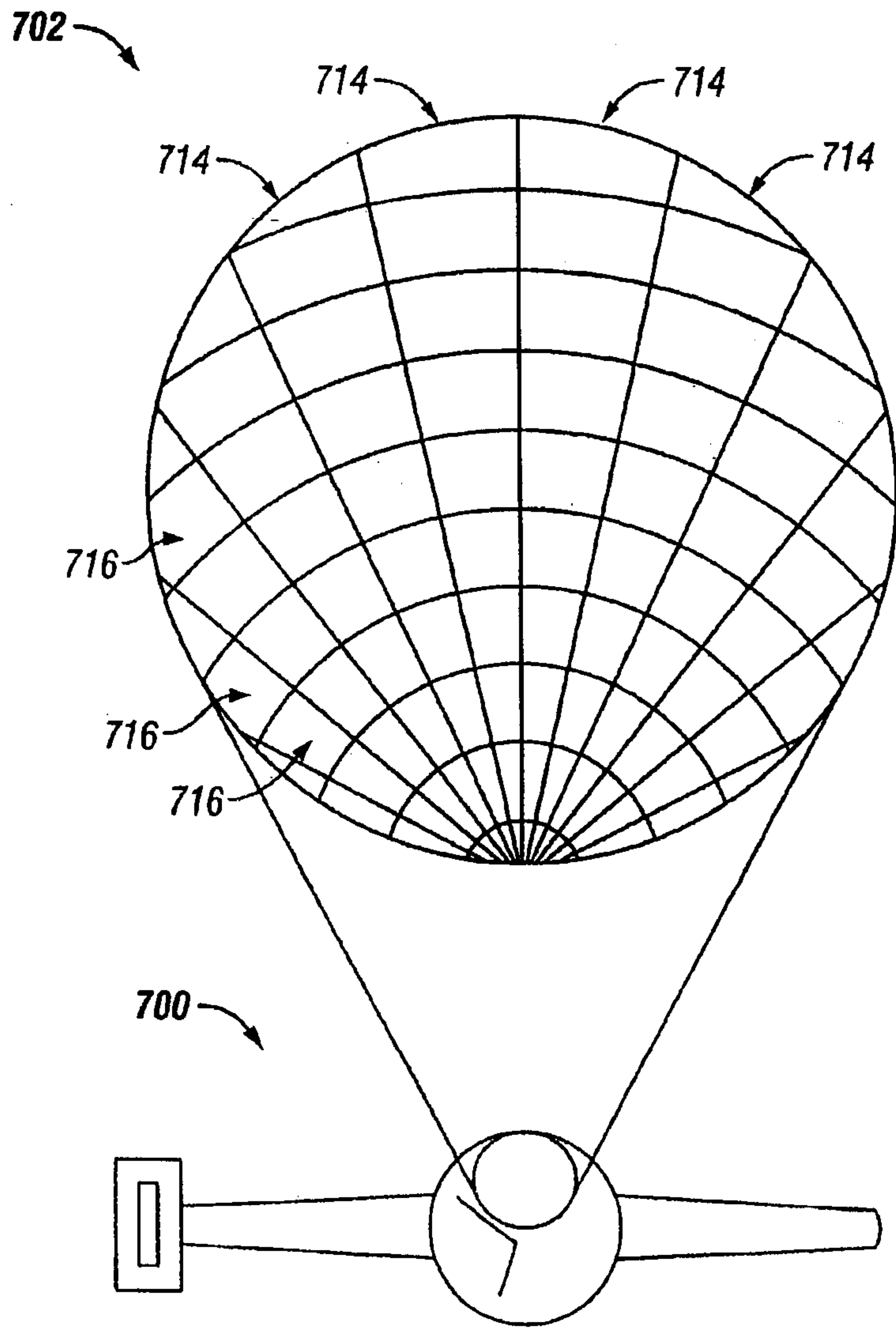

FIG. 7

7/9

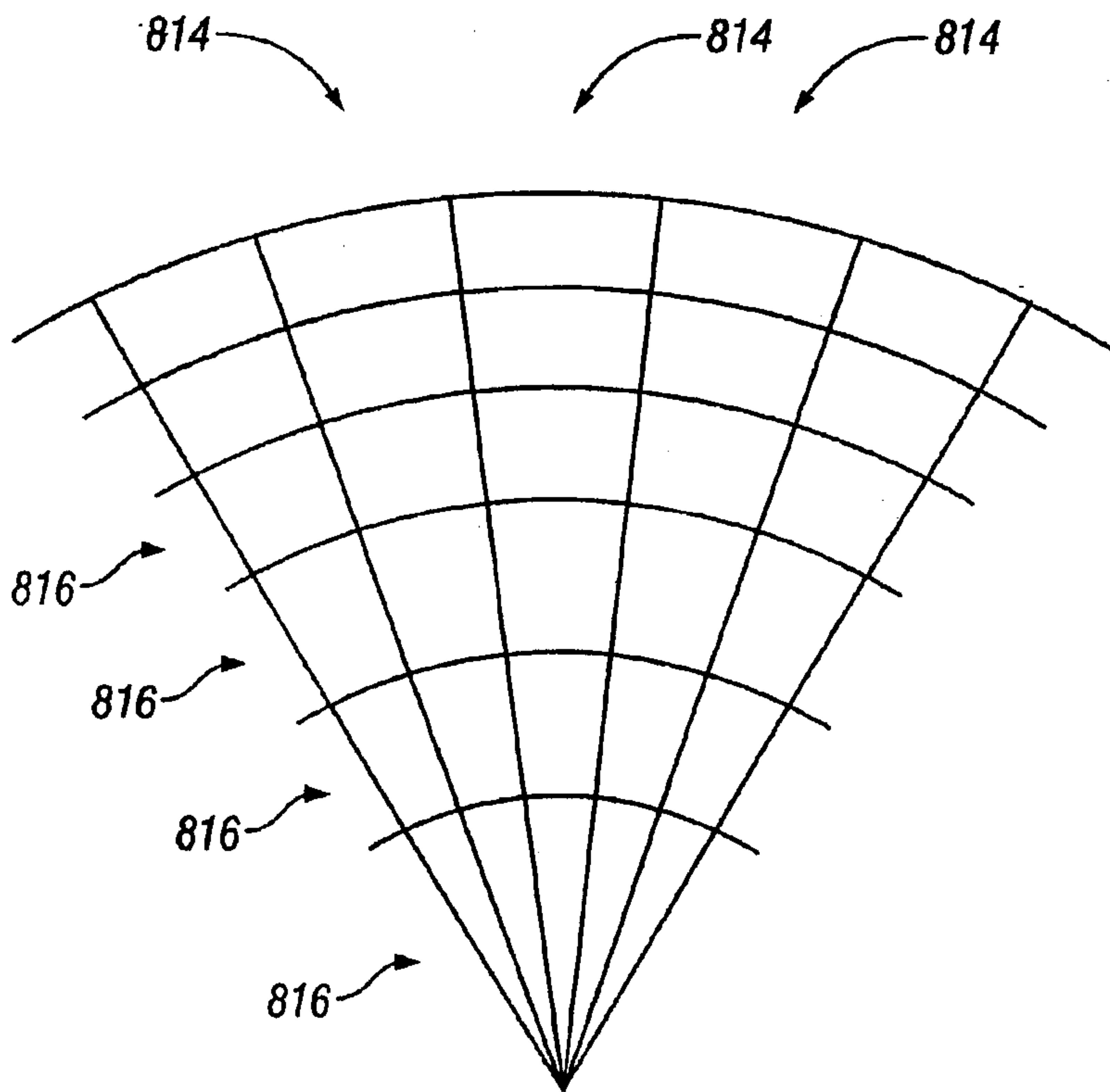

FIG. 8

8/9

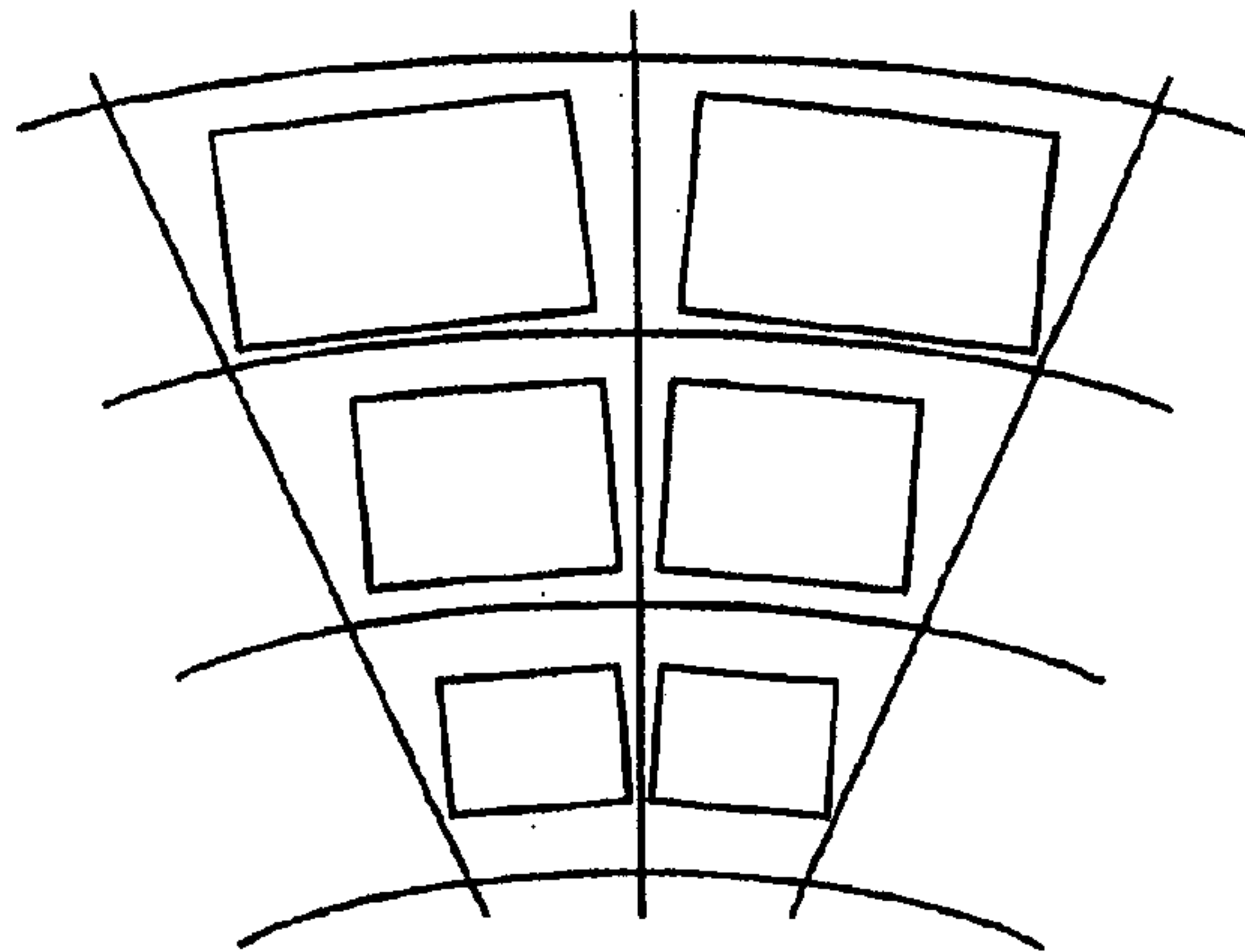

FIG. 9A

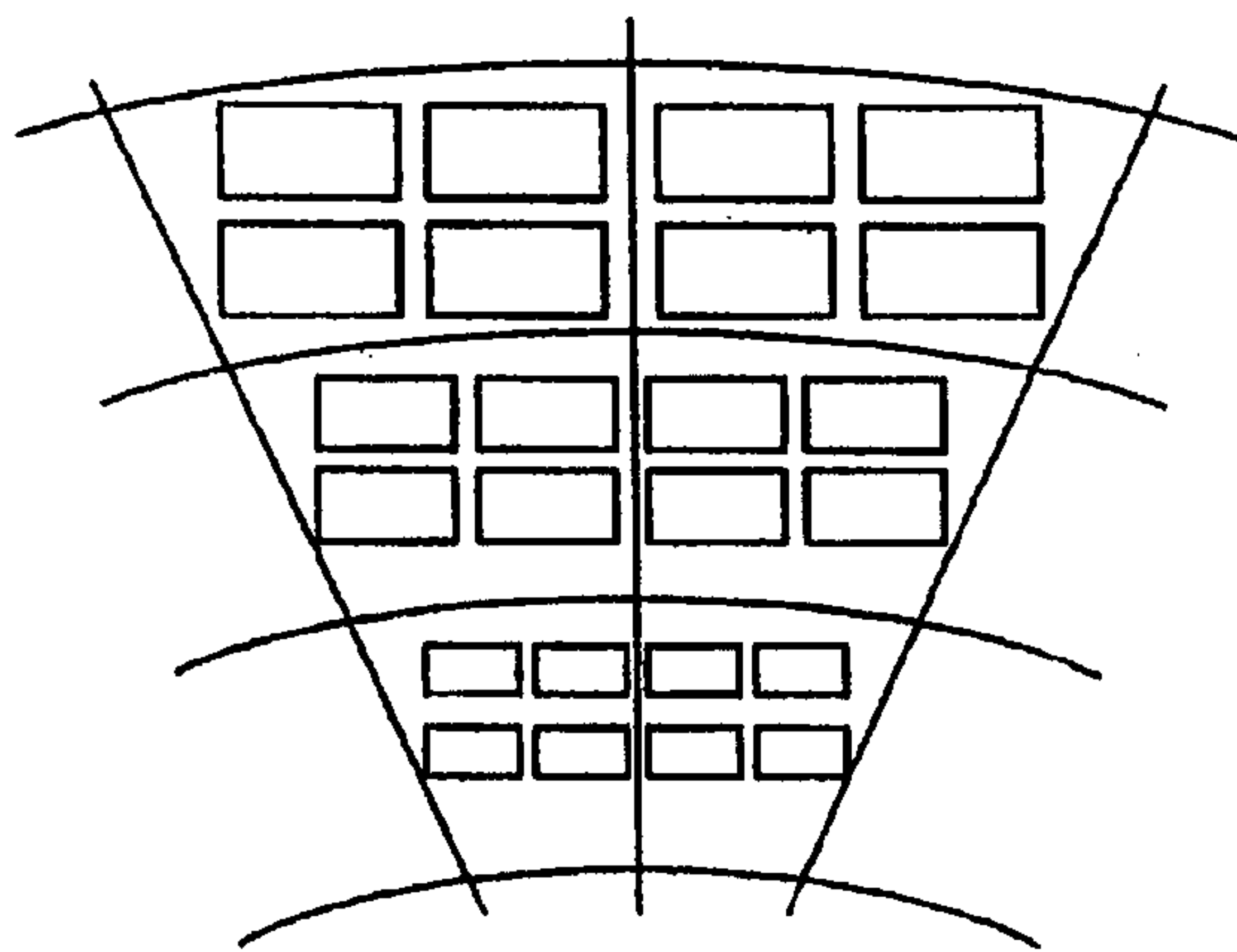

FIG. 9B

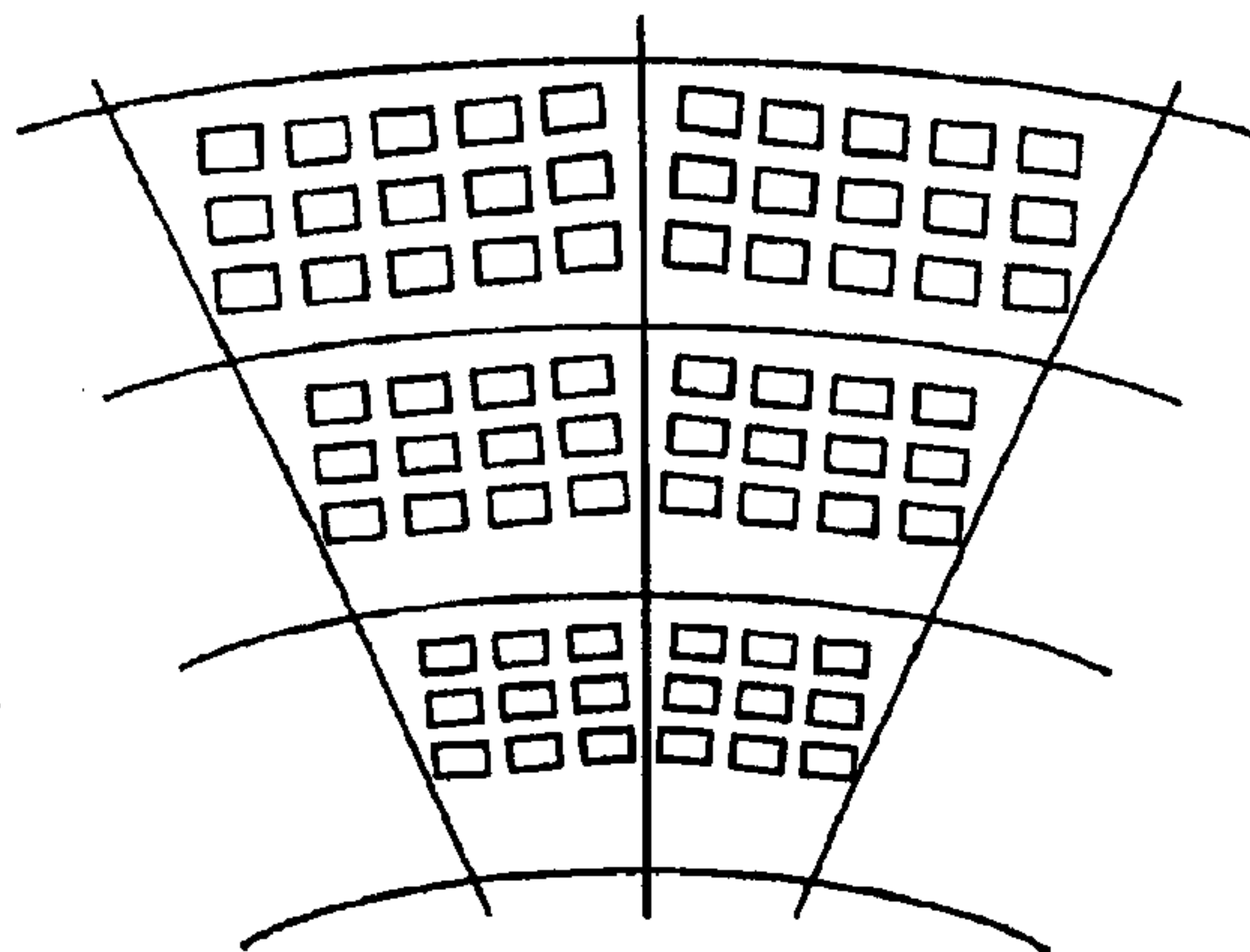

FIG. 9C

40

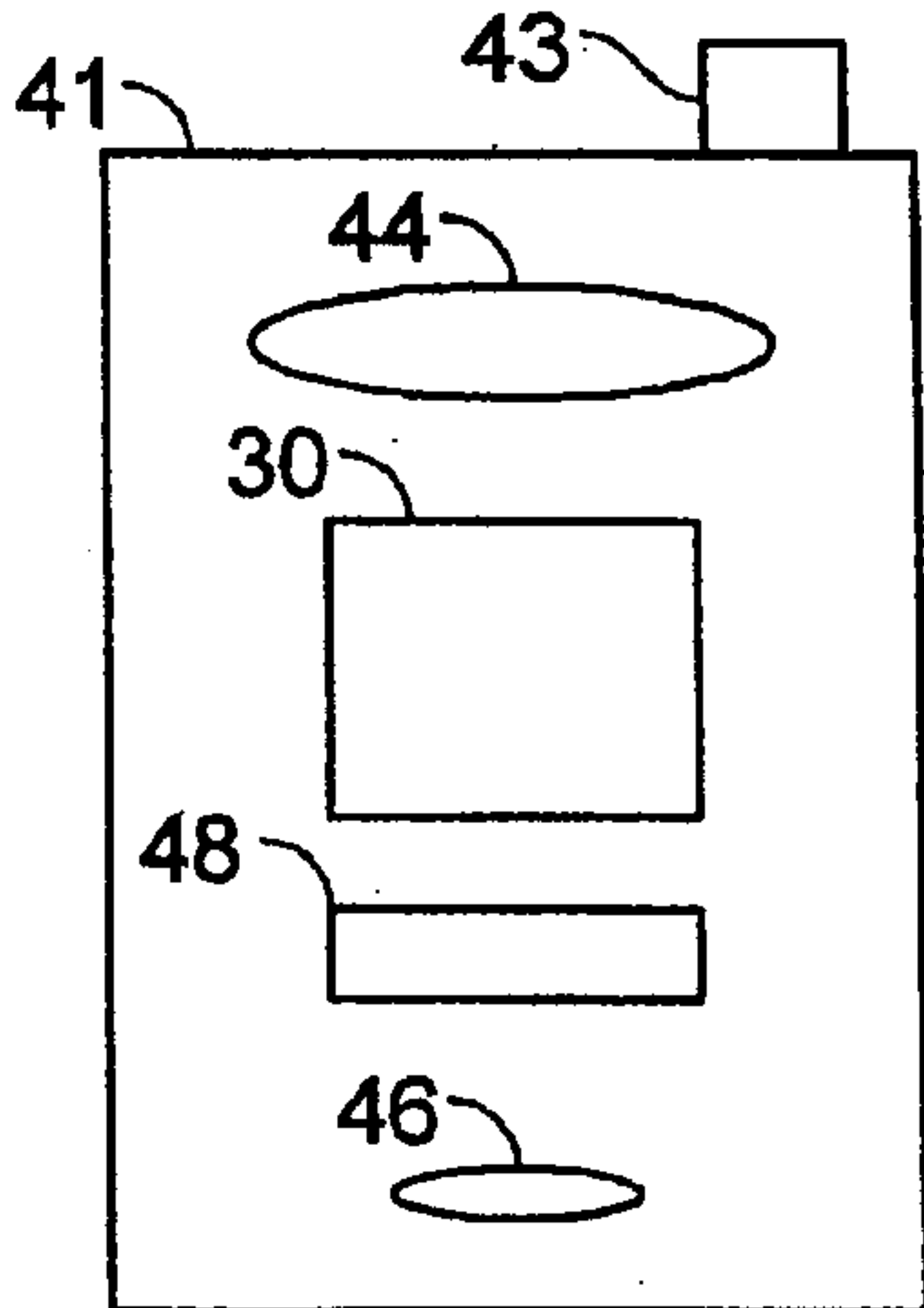

FIG. 10A

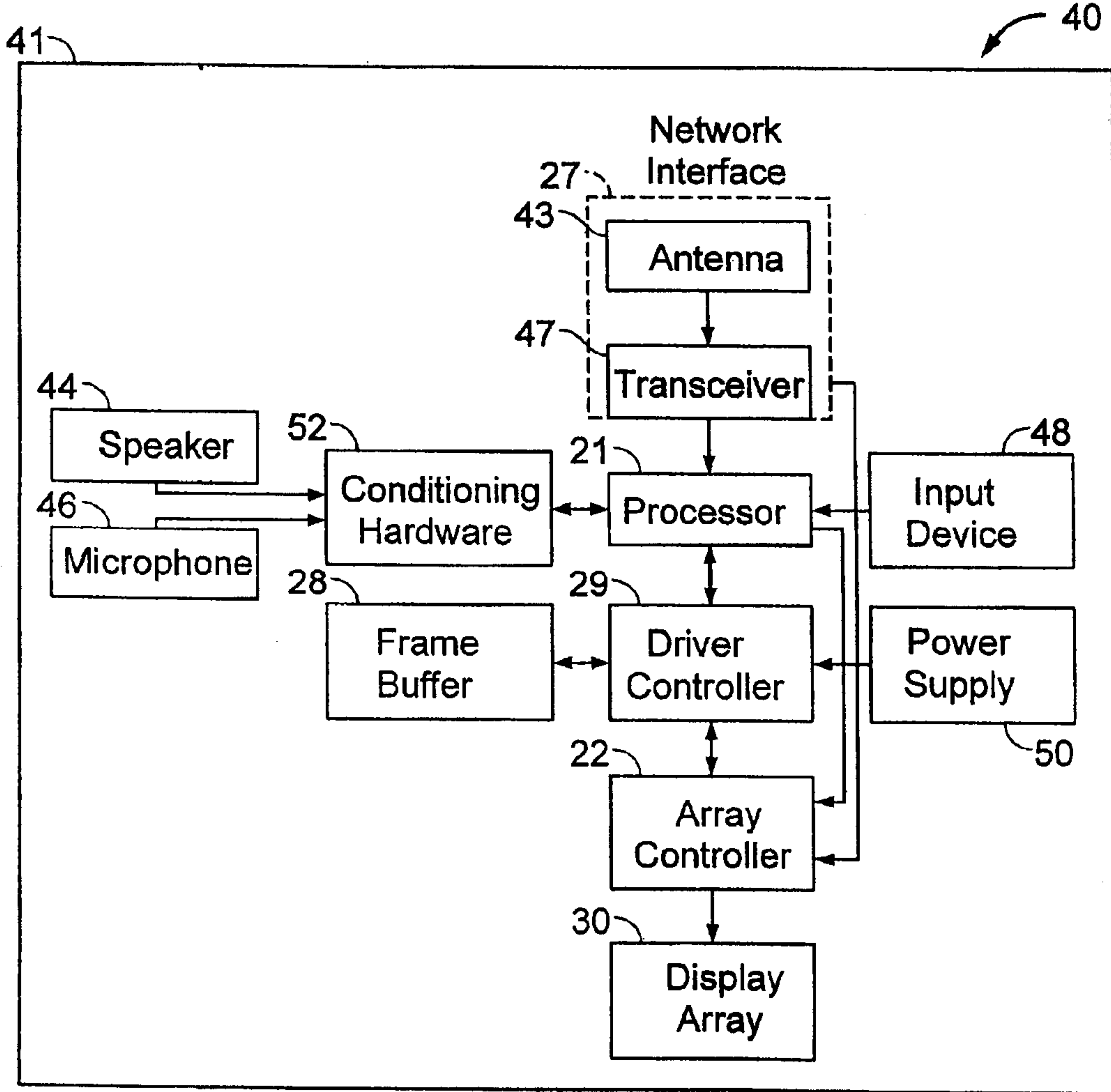

FIG. 10B

