

(19)



Europäisches Patentamt  
European Patent Office  
Office européen des brevets



(11)

**EP 1 568 816 A2**

(12)

**EUROPEAN PATENT APPLICATION**

(43) Date of publication:

**31.08.2005 Bulletin 2005/35**

(51) Int Cl.7: **D06F 39/14, D06F 39/00**

(21) Application number: **05009529.8**

(22) Date of filing: **07.08.2001**

(84) Designated Contracting States:

**AT BE CH CY DE DK ES FI FR GB GR IE IT LI LU  
MC NL PT SE TR**

Designated Extension States:

**AL LT LV MK RO SI**

(72) Inventors:

- **Bükülmez, Bora c/o Arcelik A.S.  
81719 Tuzla Istanbul (TR)**
- **Kutlay, Engin c/o Arcelik A.S.  
81719 Tuzla Istanbul (TR)**

(30) Priority: **11.08.2000 TR 200002362**

(74) Representative: **LOUIS, PÖHLAU, LOHRENTZ**

(62) Document number(s) of the earlier application(s) in accordance with Art. 76 EPC:

**01967926.5 / 1 309 749**

**P.O. Box 30 55**

**90014 Nürnberg (DE)**

(71) Applicant: **Arcelik A.S.**

**81719 Istanbul (TR)**

Remarks:

This application was filed on 30 - 04 - 2005 as a divisional application to the application mentioned under INID code 62.

(54) **A washing machine with washing steps monitored remotely**

(57) The present invention is related to a washing machine (16), preferably of the front-loading type, with the control and indicator panel provided on the loading door (1) and which can be monitored from a remote distance. The loading door (1) comprises one or more than one transparent pieces comprising the illuminating, controlling parts and equipment. Required symbols are marked on said pieces, using various printing techniques. Parts that are not desired to be shown are covered, again preferably by using printing techniques or

by painting. Said loading door (1) is connected to the cabinet by a hinge (6) and the lighting, controlling parts and equipment can be connected to the required points by means of the hinged region and of the electrical cables (26) in the protecting hose (3). The handle (5) on the frame provides the locking of the loading door (1) and may be detached from the machine after locking, so that it can remotely control the programs by means of the buttons and monitors/controls the program steps by means of the light indicators (15); thus the user is enabled to control and monitor the machine remotely.

Figure 3

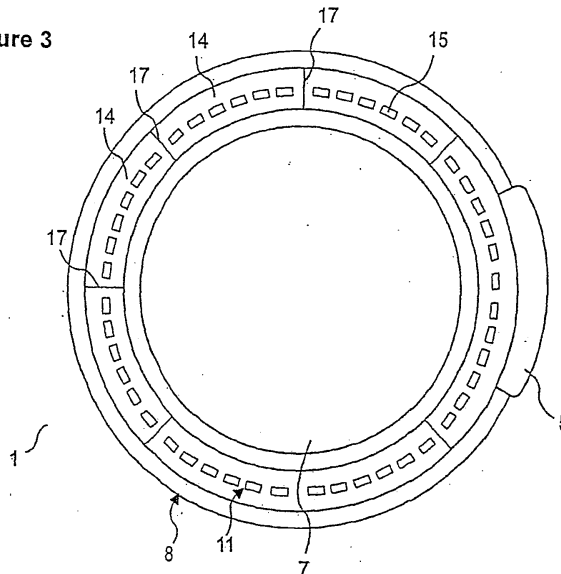

**EP 1 568 816 A2**

**Description**

**[0001]** The present invention is related to a washing machine, preferably of the front-loading type, with the control and indicator panel provided on the loading door and which can be monitored from a remote distance.

**[0002]** The control of the washing machines is made by means of the control and indicator panel which is located on the upper portion of the front wall of the cabinet. The user selects the washing cycle/program by using the buttons provided on the panel. Legends symbolizing the programs are provided on the buttons or on the surfaces where the buttons/keys are located. The selected program and its stages are generally understood by the positions of the symbols on the keys, during the rotational movement of the selected button. As the dimensions of the buttons are limited with the size of the panel, the stages of the selected program is followed in a restricted manner, the user is obliged to be in the proximity of the washing machine in order to perform the control and monitoring functions.

**[0003]** The object of the present invention is to enable the user to monitor the operation and program steps of the domestic appliances, preferably of the washing machines, from a distal position, i.e. remotely.

**[0004]** The indicator and control panel on the loading door, realized to attain the above mentioned object of the present invention, has been illustrated in the attached drawings, wherein:

Figure 1, is the three-dimensional overall front view of the washing machine.

Figure 2, is the plan view of the loading door of the washing machine in an open position.

Figure 3, is the front view of an indicator and control panel with only light indicators, located on the loading door.

Figure 4, is the front view of an indicator and control panel with buttons and light indicators, located on the loading door.

Figure 5, is the front view of an indicator and control panel with only buttons located on the loading door.

Figure 6, is the front view of an indicator and control panel with only light indicators located on the loading door, with buttons and light indicators located on the handle fixed onto it.

Figure 7, is the front view of an indicator and control panel with only light indicators, located on the loading door with buttons and light indicators located on the detachable handle.

Figure 8, is the front view of a loading door with a detachable handle which has buttons and light indicators.

Figure 9, is the side cross-section view of a part of the frame wherein the light indicators are present.

Figure 10, is the three dimensional view of the handle and handle recess.

Figure 11, is the schematical view of the parts con-

stituting the locking mechanism.

**[0005]** The components shown in the drawings have been separately enumerated as follows :

- 5 1. Loading door
2. Control and indicator panel
3. Protection hose
4. Handle recess
- 10 5. Handle
6. Hinge
7. Windows
8. Frame
9. Front wall
- 15 10. Locking mechanism
11. Frame surface
12. Frame body
13. Frame recess
14. Compartment
- 20 15. Light indicator
16. Washing machine
17. Rib
18. Button
19. Contact plate
- 25 20. Front Wall Lock Handle
21. Loading Door Hook
22. Spring
23. Tub
24. Bellow
- 30 25. Circuit board
26. Cable
27. Separating button
28. Handle hook recess
29. Handle hook

**[0006]** The domestic appliances, such as washing machines (16) of the front-loading type, comprise a loading door (1) to load the laundry to be washed into the machine, a tub (23) wherein the laundry is placed, a bellow (24) to provide an isolation between the loading door (1) and the tub (23). A circular window (7) in the form of a recess is provided at the center of the loading door (1) in order to avoid the laundry from being pinched into the bellow (24) during the washing cycle. Said window (7) made in a circular shape in line with that of the loading door, is preferably made of glass due to such factors as resistance to scratching and easy monitoring. A plastic frame, (8) preferably in a circular shape is provided around said window (7). Said frame (8) comprises one or more than one pieces. In a preferred embodiment of the present invention, a frame surface (11) is provided above the frame (8) and a frame body (12) below it. A handle (5) provided on the frame surface (11) is controlled outside the washing machine (16) and is located in the handle recess (4) opened on the frame (8). One or more than one hinge(s) (6) that are fastened onto the frame body (12) below the frame (8), are preferably located just opposite the handle (5). The loading door (1)

is attached to the front wall (9) of the washing machine (16) by means of said hinge(s) (6), and is opened/closed by a pivotal movement around the axis of the hinge. Said hinge (6) also supports the cables (26) from the control panel (2) on the loading door (1), to pass towards the inner sections of the washing machine (16) in a protecting hose (3) in order to provide isolation and to avoid any deformations. Said protecting hose (3) provides the isolation required for the cables and prevents any deformations that may occur during the movements of the hinge. The closing, locking and opening of the loading door (1) is ensured by a locking mechanism (10) connected to the handle (5).

**[0007]** The control and indicator panel (2) is placed in a frame recess (13) located below the frame surface (11) and in the frame body (12). Said control and indicator panel (2) may be so made as to show only the washing programs and stages or only as to control the operational programs of the machine or as both to show and control the washing programs and stages of the machine. The indicator and control panel comprises the buttons (18) by means of which the washing machine (16) programs are determined by the user; light indicators (15) showing the course of the program; circuit boards (23) to which the buttons (18) and light indicators (15) are connected; and cables (26) connecting all of the above components to each other and to the control unit. The frame recess (13) comprises one or more compartments (14) which are divided by ribs (17). The compartments (14) are provided with controllable light indicators (15) such as leds or lamps, buttons (18), circuit boards (25), and cables (26). The circuit boards (25), therefore the buttons (18) and light indicators (15) are connected to each other between the compartments (14) by means of cables (26) and reach the programming device and control unit provided in the washing machine; over the hinge (6) which is below the frame body (12). Said programming device and the control unit, operate the washing machine (16) according to the commands received from the control panels (2).

**[0008]** The frame surface (11) is made of transparent or light transmitting, preferably of semi-transmitting material or glass, so that the control panel (2) located underneath can be seen from outside the loading door (1). Depending on the material used, said frame surface (11) is attached to the frame body (12) as snap-fitted or mechanically or by various welding techniques such as vibration, ultrasonic welding, and the like. The frame (8) or the frame surface (11), before or after being attached, depending on the purpose, location and material of use, is preferably painted and/or printed by using various techniques. During printing, symbols, signs, legends, and letters of a size and color that can easily be differentiated from a distance; are used. For the indications made on the frame, badges or material that can be glued later on, may also be used.

**[0009]** The light indicators (15) on the circuit board (25) attached on the frame body (12) are turned on ac-

5 cording to the program steps, in order to illuminate the printed surface preferably with illustrative signs from below. The reflectors on the inner surfaces of the compartment (14) and the circuit board (25) are used to direct the light toward the frame surface (11). In this manner a potent light source is obtained by consuming little energy. Meanwhile the leakage of light to other compartments (14) is provided by the ribs (17) defining the compartments (14) which enable different program stages to be separated from each other and shown, and thus to be monitored over the loading door (1). The frame surface (11) in turn, which is prepared according to the key out in the compartments (14) describes, by means of symbols or letters, the washing programs and/or stages selected, by the user to the user, by virtue of the printings made on the inner and/or outer surface of the frame.

10 In an embodiment wherein only the washing programs or stages of the washing machine (16) are monitored, the compartments (14) of the frame (8) are preferably arranged in such an order that they show the pre-washing, main washing, water drainage, rinsing, water softener application, spinning, door-opening steps. The light indicators (15) are "on or off" depending on the order of washing stage and/or time. In one embodiment, all light indicators (15) in the compartment showing the selected washing program are illuminated when the program button is pressed. As the washing stages are completed, the light indicators (15) pass to the "off" position respectively. In another embodiment, only the light indicator (15) showing the current washing stage is illuminated, for the purpose of energy saving and to lengthen the service life of the light indicator (15).

20 **[0010]** In the preferred embodiment, the light indicators (15) start to be illuminated according to the washing stages and when a certain stage is completed, all light indicators (15) associated with that stage will be illuminated. Thus, the user can easily follow the washing program and see at which stage it is.

30 The frames where both the programs are controlled and the stages are followed, the control and indicator panel (2) is provided with both the light indicators (15) showing the control stages, and the buttons (18) directing the washing programs and stages (Fig.4). Said light indicators (15) and buttons (18) are placed in the compartments (14) provided in the frame body (12). Said compartments (14) are so placed that they can be contained in the circular loading door (1), depending on the program stages and timings. The user illuminates a light indicator (15) showing the mode of operation by pressing the button (18) on the compartment showing the program she has selected and operates the washing machine (16). During the course of operation, the light indicators (15) present in this compartment (14) are respectively illuminated and inform the user about the operational status of this mode. The user can also be informed about the operation stages by virtue of these light indicators (15). The light indicators (15) associated

with the current washing step, during the consecutive course of steps such as washing, rinsing, spinning, etc., preferably keep on being illuminated until said selected group of washing steps is completed.

**[0011]** In the frames (8) where only washing programs are controlled, one or more button(s) (18) are placed at different locations on the frame (8), depending on the purpose and place of use (Fig.5). The buttons (18) are preferably placed so that they are located at the uppermost sections of the frame (8) for user's comfort. In this manner, the user who has bent down to load the laundry into the washing machine (16) and closed the loading door (1), is able to select the washing program without standing up again. As the uppermost sections of the frame (8) is more proximal to the upper region of the washing machine (16), the user can reach the buttons (18) without bending if she is standing up or without having to stand up if she is in a bending position.

In a preferred embodiment of the present invention, the handle (5), in addition to the frame (8), is also used for control and/or indication. In such embodiments, the frame (8) and the handle (5) are so made that they complement each other and/or they can be used separately. The handle (5) may be fixed onto the frame (8) or it can be detached from the frame (8) to function as a remote controller. Thus, the user can remotely monitor the fundamental steps of the program she has selected and can direct the machine (16) when required, by selecting programs. Whereas, in cases when the user is able to see the loading door (1) of the washing machine (16), she can follow the stages of the selected program, over the loading door (1), by means of the light indicators (15).

**[0012]** In one of the embodiments where both the handle (5) and the frame (8) are used, the selected program and its steps are followed (monitored) by means of the light indicators (15) on the frame (8) and programs are controlled and selected by means of the buttons (18) on the handle (5), in addition to the possibility to monitor the selected programs and/or steps by means of the light indicators (15) on the handle (5) (Fig. 8).

**[0013]** In another embodiment, all control and monitoring are made only on the handle preferably in a fixed manner (Fig.8). For such reasons as practical usage and facility of installation, the buttons (18) and light indicators (15) are preferably located on the handle (5) whereas the frame (8) is used for monitoring and/or control, according to the characteristics of the washing machine used.

**[0014]** Yet in another embodiment, all controls are made on the frame (8) by means of the buttons (18) and the handle (5) is used only to monitor by means of the light indicators (15). In another embodiment, both the programs are selected, and/or controlled, by means of the buttons (18) provided both on the frame (8) and the handle (5), and the programs and/or its stages are monitored by means of the light indicators provided both on the frame (8) and on the handle (5) (Fig.7).

In the embodiments where the handle (5) is used for control and/or indication, preferably the handle (5) cannot be detached before the loading door (1) is closed. When the loading door is closed, the handle (5) remains attached in the handle recess (4) until the separating button (27) on the handle (5) is pressed. When said separating button (27) is pressed, the handle (5) is released and detached from the loading door (1). After the detachment of the handle (5), the loading door (1) cannot be opened before the handle (5) is attached back to its place. This is provided preferably by the locking mechanism (10) operating mechanically. Therefore, whenever the handle (5) is seated into its recess, the loading door (1) can be opened by means of the locking mechanism (10), regardless of whether the mains voltage is on or off.

**[0015]** The handle (5) is connected to a locking mechanism (10), which preferably comprising a front wall lock handle (20), a loading door hook (21), a handle hook recess (28) on the loading door hook (21), a handle hook (29) and springs (22). In a preferred locking mechanism (10) embodiment, the loading door hook (21) is engaged to the front wall lock handle (20) when the loading door (1) is closed. In this case, the loading door hook (21) remains at a fixed position, parallel to the handle (5). Meanwhile, when the separating button (27) is pressed, the handle hook (29) connected to the separating button (27) rotates in a pivoting motion around a joint and thus the tip of the handle hook (29) is released from the hook recess (28). When the separating button (27) is released, it takes its original position by virtue of the spring provided on its rotational axis. Whereas, in case when the loading door (1) is open, the loading door hook (21) moves in a reverse direction, due to a spring on its rotational axis, and presses the handle hook (29) in its recess. (28) and prevents it from being released out of its place.

**[0016]** When the buttons (18) on the handle (5) are pressed, the command is transmitted to the connecting cables (26) by means of the contact plates (19); and the connecting cables (26) passing through the loading door (1) and through the hinge (6) region, reach the control card. When the handle (5) is detached from the loading door (1), information received by means of a receiver located at the upper control panel of the washing machine from the transmitter of the handle (5), is transmitted to the control unit.

In addition to the program buttons (18), open/close buttons (18), such economy buttons as those providing economical water intake or operation with less energy may also be provided on the handle (5). As the buttons (18) indicating programs are preferably illuminated, the user can see which program has been selected. In cases when the buttons are not illuminated, preferably a light indicator (15) is illuminated when they are pressed. The program stages are indicated by means of more than one light indicator (15) preferably provided on the handle, and which are used by all program buttons (18).

Said light indicators (15) operate preferably as synchronized with the light indicators on the loading door (1).

**[0017]** The control of the programs and monitoring the program stages of the washing machine (16) by means of a control and indicator panel located on the loading door (1) and/or the handle (5) are also applicable for the other domestic appliances such as drivers and the like.

### Claims

1. A washing machine (16) the washing steps of which can be remotely monitored, **characterized** with a handle (5) that may preferably be used as a remote controller, which comprises light indicators (15) showing the washing program and its steps, and/or buttons (18) by which the operational programs of the washing machine are controlled.
2. A washing machine (16) the washing steps of which can be remotely monitored as defined in claim 1, **characterized** with a locking mechanism (10) connected to the handle, which can open/close a loading door (1) to load the laundry to be washed into the machine and which comprises a front wall lock handle (20), a loading door hook (21), a handle hook recess (28), a handle hook (29) and springs (22).
3. A washing machine (16) the washing steps of which can be remotely monitored as defined in claim 1 or 2, includes a loading door (1) to load the laundry to be washed into the machine, **characterized with** a control/indicator panel placed on said loading door (1), which comprises light indicators (15) showing the washing program and its steps and/or buttons (18) by which the operation programs of the washing machine are controlled.
4. A washing machine (16) the washing steps of which can be remotely monitored as defined in claim 3, **characterized** with a loading door (1) comprising a window (7), a plastic frame (8), preferably in a circular shape including one or more than one pieces, provided around said window (7), a hinge (6) providing its connection to the front wall (9) and opening/closing of the door (1), and a handle (5) connected to the frame (8) and providing locking and re-opening of the door (1).
5. A washing machine (16) the washing steps of which can be remotely monitored as defined in claims 3 to 4, **characterized** with a frame (8), comprising a frame surface (11) above and a frame body (12) below it; a frame recess (13) below the frame surface (11) and in the frame body (12), wherein the control and indicator panel (2) is located; and one or more than one compartment(s) (17) in the frame recess

(13) which are separated by ribs (17), wherein controllable light indicators (15), buttons (18), circuit boards (25), cables (26) are placed.

- 5 6. A washing machine (16) the washing steps of which can be remotely monitored as defined in claims 3 to 5, **characterized** with a hinge (6) that supports the cables (26) from the control panel (2) on the loading door, to pass towards the inner sections of the washing machine (16) in a protecting hose (3) in order to provide isolation and to avoid any deformations.
- 10 7. A washing machine (16) the washing steps of which can be remotely monitored as defined in claims 3 to 6, **characterized with** the frame surface (11), made of transparent or light transmitting, preferably of semi-transmitting material or glass, so that the control panel (2) located underneath can be seen from outside the loading door (1), attached to frame body (12) as snap-fitted or mechanically or by various welding techniques such as vibration, ultrasonic welding, depending on the purpose, location and material of use, is preferably painted and/or printed by using various techniques by using symbols, signs, legends, and letters of a size and colour that can easily be differentiated from a distance.
- 20 8. A washing machine (16) the washing steps of which can be remotely monitored as defined in claims 3 to 7, **characterized** with reflectors located on the inner surfaces of the circuit board (25) and the compartments (14), and used for directing the light of the printed frame surface (11).
- 25 30 35 40 45 50 55

Figure 1

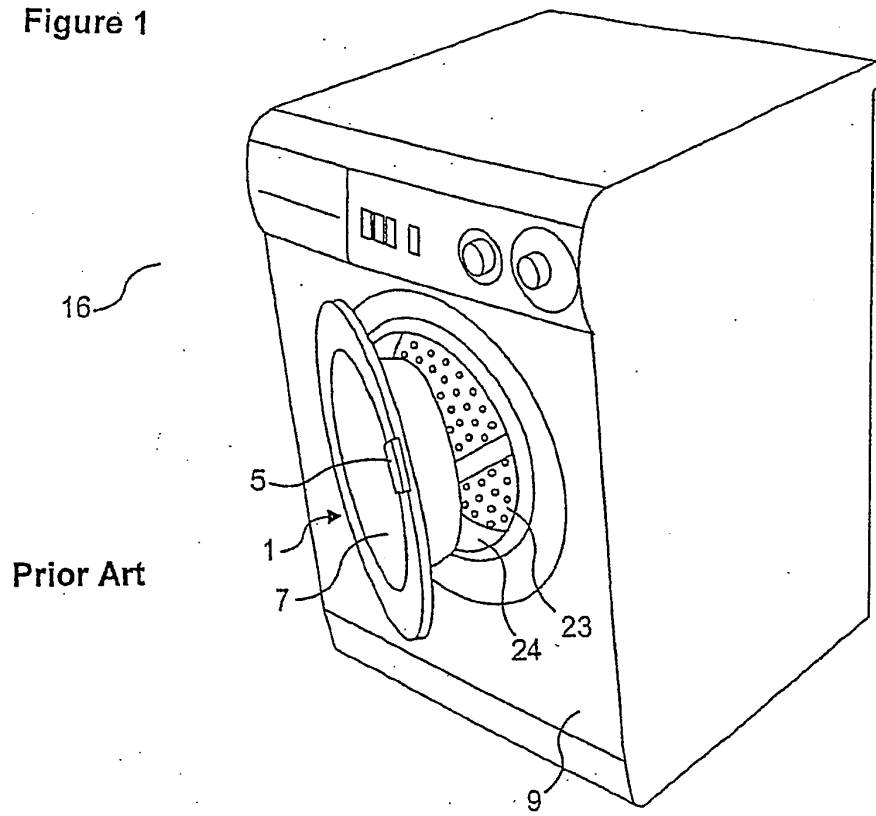

Prior Art

Figure 2

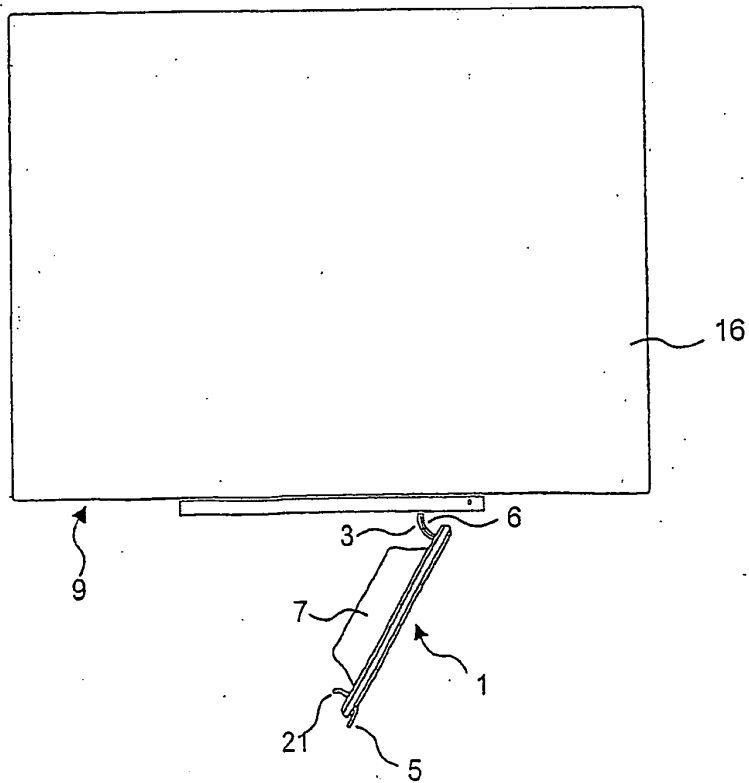

Figure 3

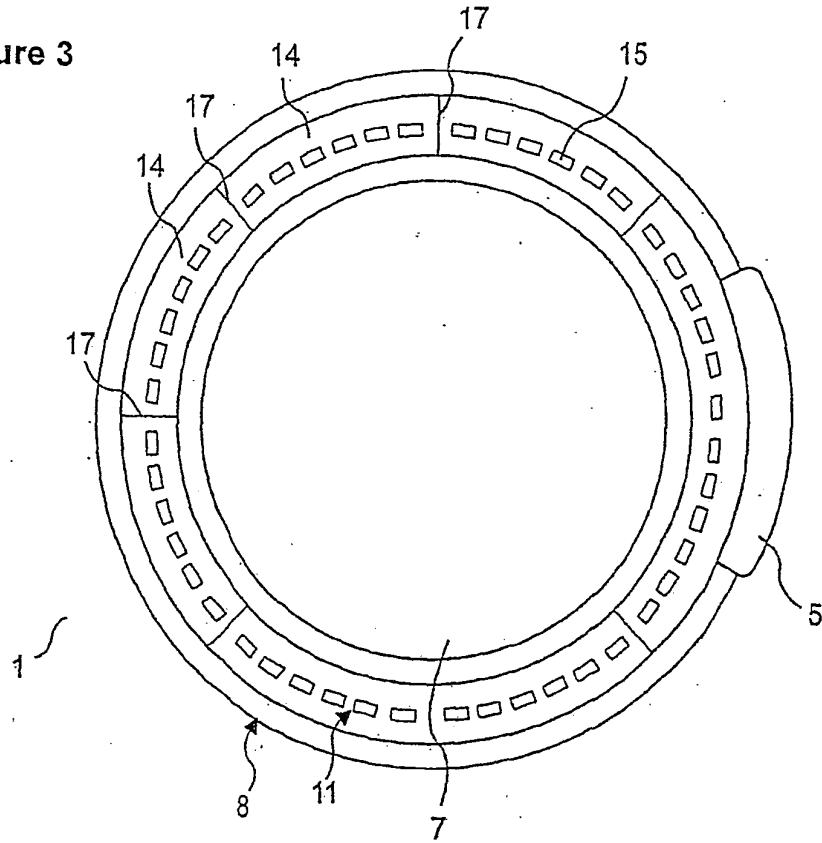

Figure 4

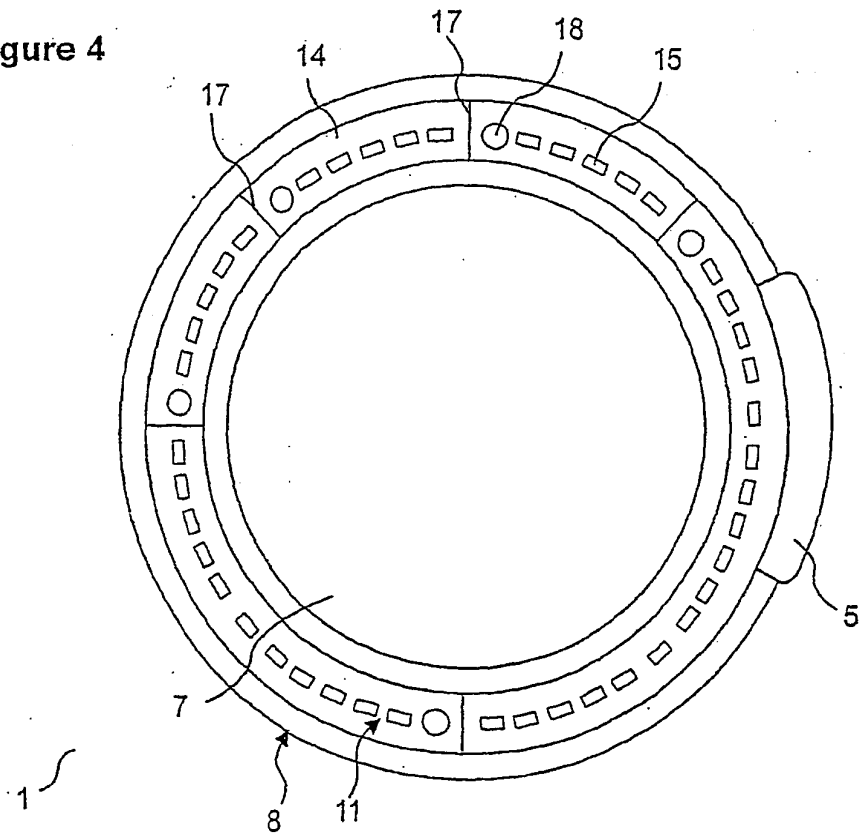

Figure 5

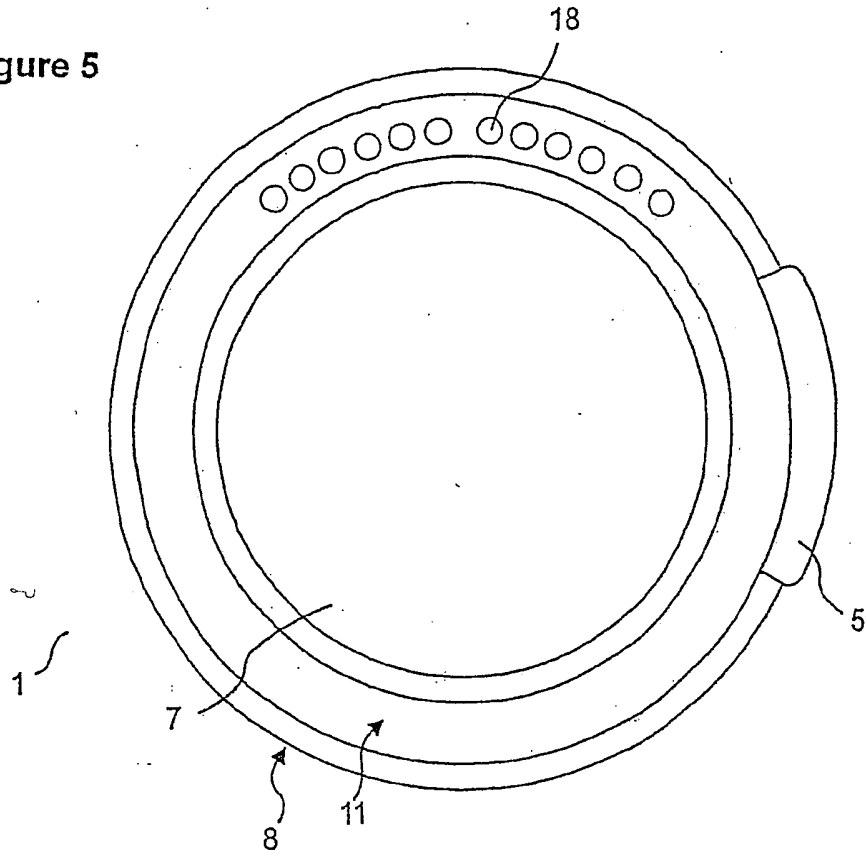

Figure 6

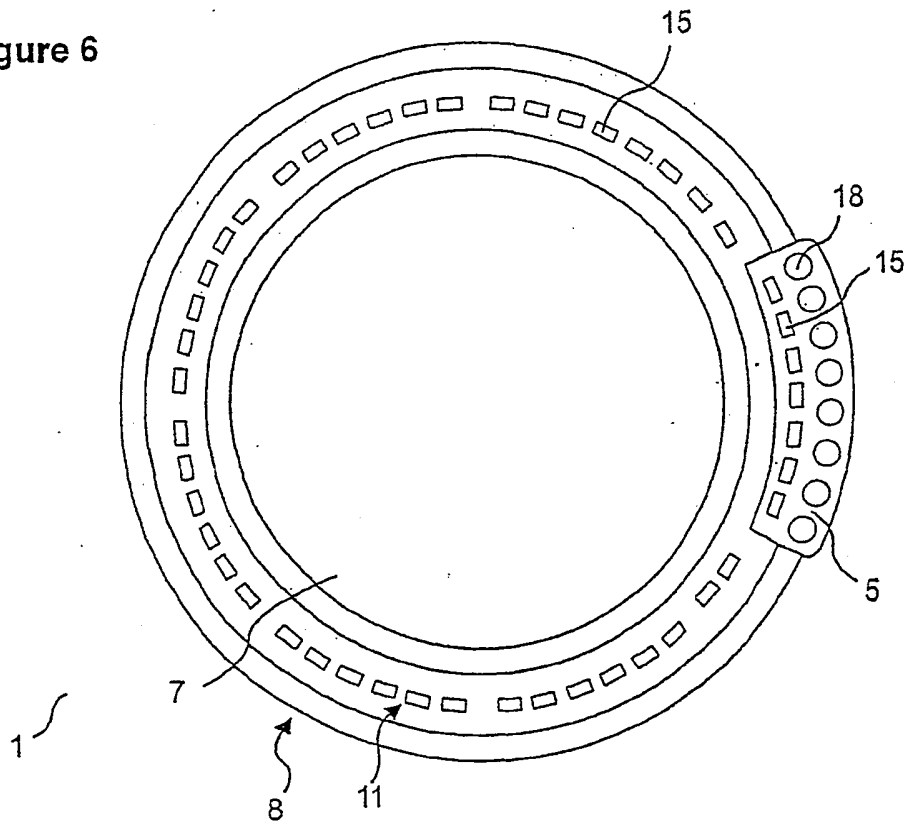



Figure 7

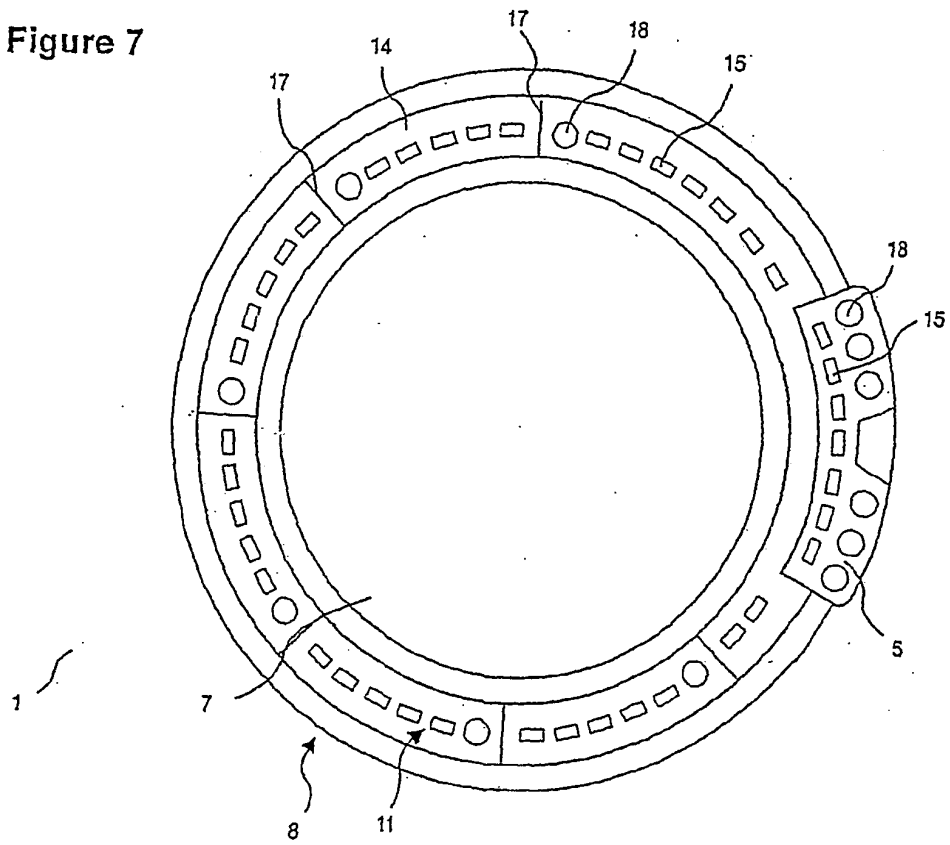

Figure 8

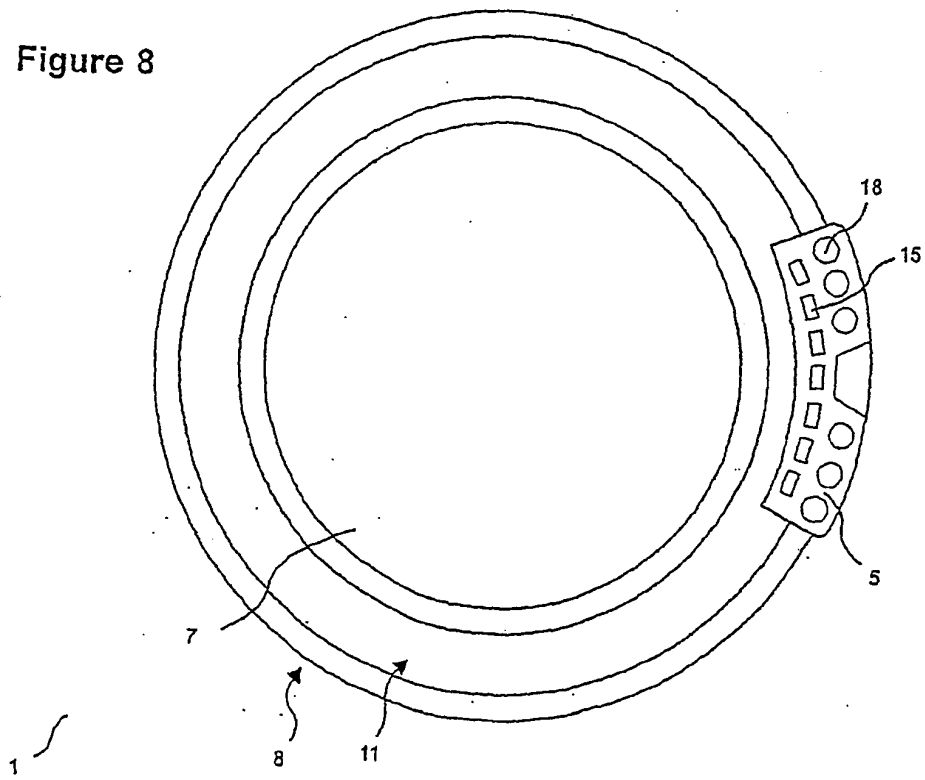

Figure 9

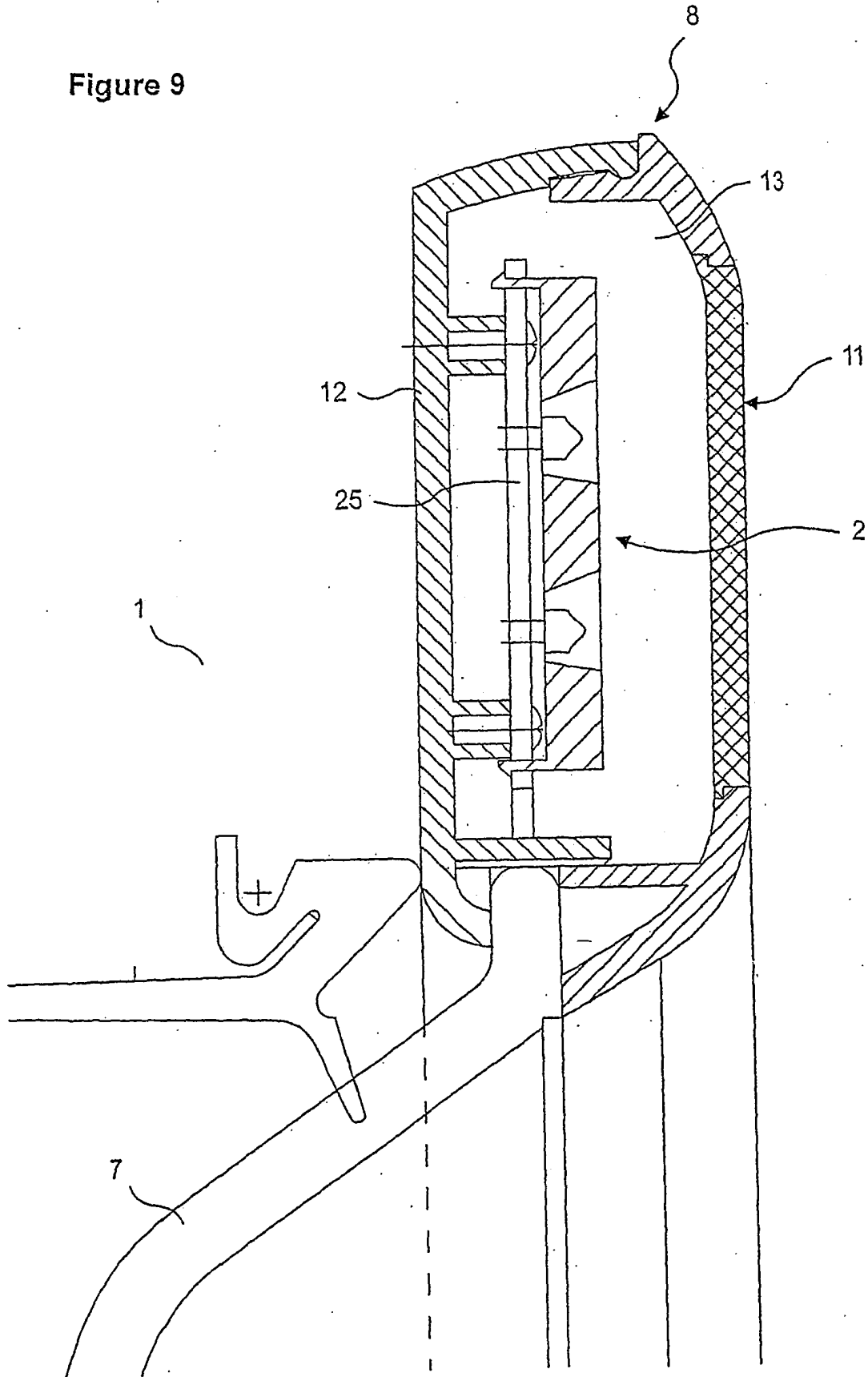

Figure 10

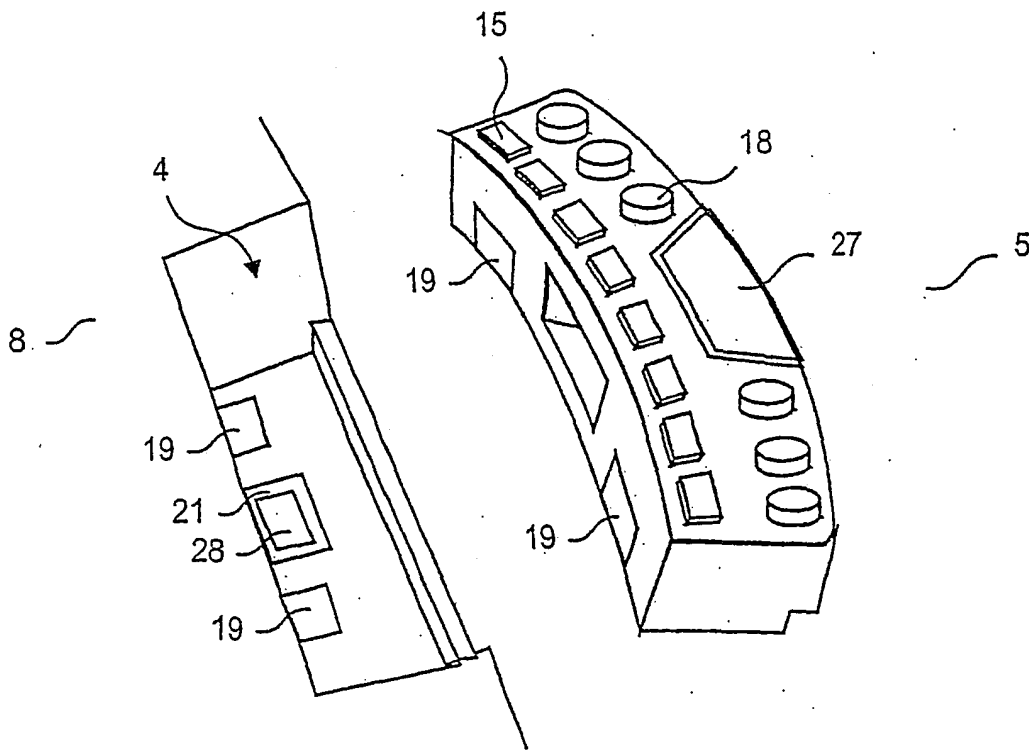

Figure 11

