

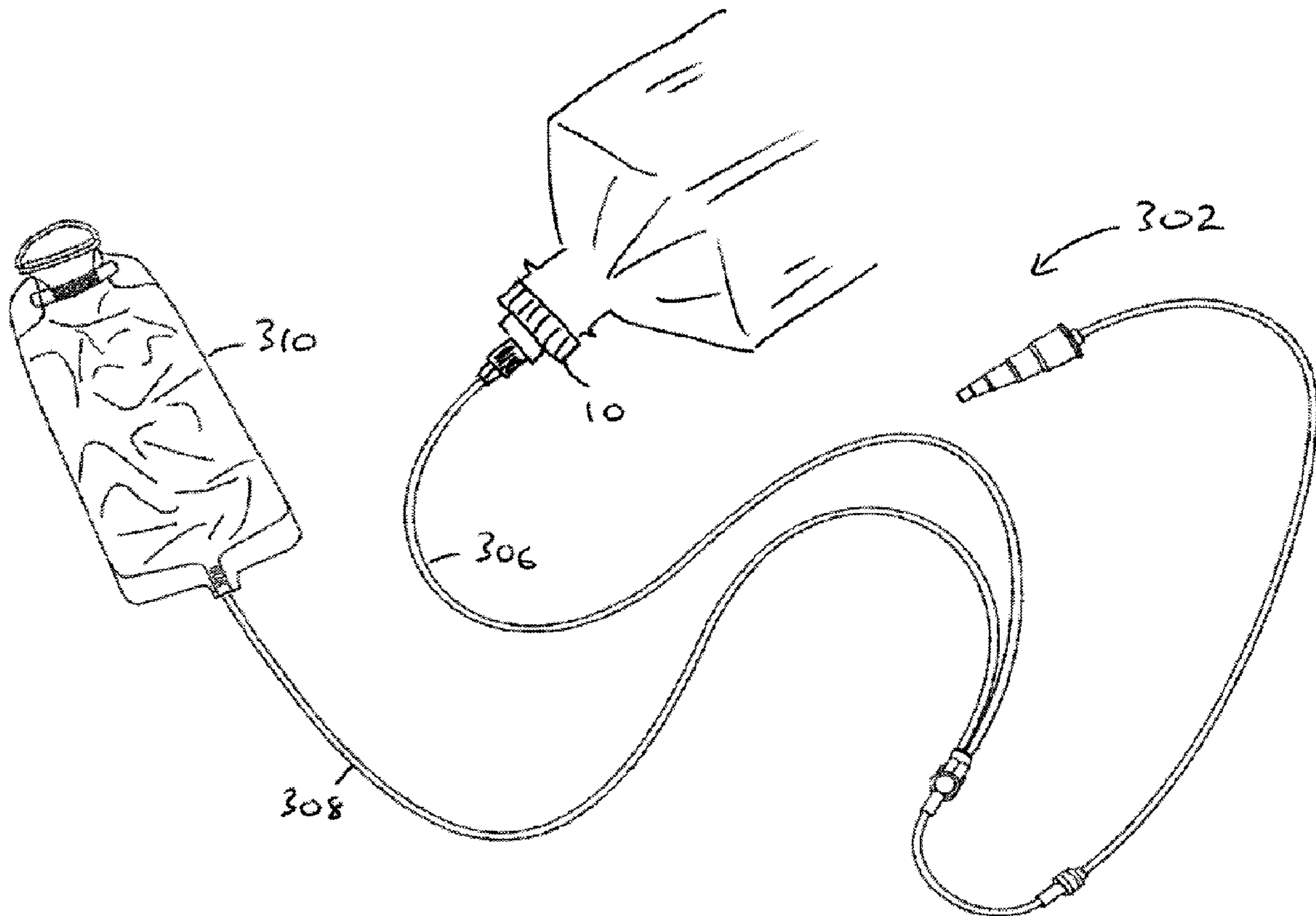

(22) Date de dépôt/Filing Date: 2007/11/14  
 (41) Mise à la disp. pub./Open to Public Insp.: 2008/05/17  
 (45) Date de délivrance/Issue Date: 2013/12/31  
 (30) Priorité/Priority: 2006/11/17 (US11/561,283)

(51) Cl.Int./Int.Cl. *A61J 15/00* (2006.01),  
*A61M 39/12* (2006.01)  
 (72) Inventeur/Inventor:  
DALY, PAUL J., IE  
 (73) Propriétaire/Owner:  
TYCO HEALTHCARE GROUP LP, US  
 (74) Agent: SMART & BIGGAR

(54) Titre : ENSEMBLE D'ALIMENTATION ENTERALE  
 (54) Title: ENTERAL FEEDING SET



(57) Abrégé/Abstract:

The present invention provides an enteral feeding set comprising tubing adapted for fluid flow therethrough and further adapted to be engaged by a pump unit, a valve mechanism in direct communication with said tubing, said valve mechanism being adapted to

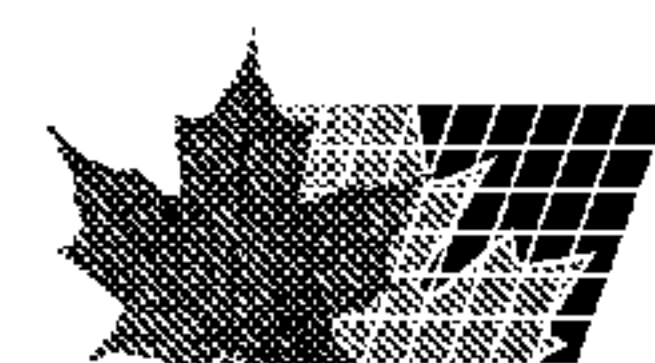

(57) **Abrégé(suite)/Abstract(continued):**

be engaged by said pump unit, and a feeding set indicator for permitting identification of the functional configuration of said administration feeding set by said pump unit, characterized in that said tubing comprises at least two inlet tubes on an upstream side of said valve mechanism and a single outlet tube on a downstream side thereof and wherein said inlet tubes each include a connector for connecting said tube to a supply of fluid at a connection end thereof, each of said connectors being of like form but visually distinguishable for indicating to a user which supply of fluid each connector should be attached thereto.

**ABSTRACT**

The present invention provides an enteral feeding set comprising tubing adapted for fluid flow therethrough and further adapted to be engaged by a pump unit, a valve mechanism in direct communication with said tubing, said valve mechanism being adapted to be engaged by said pump unit, and a feeding set indicator for permitting identification of the functional configuration of said administration feeding set by said pump unit, characterized in that said tubing comprises at least two inlet tubes on an upstream side of said valve mechanism and a single outlet tube on a downstream side thereof and wherein said inlet tubes each include a connector for connecting said tube to a supply of fluid at a connection end thereof, each of said connectors being of like form but visually distinguishable for indicating to a user which supply of fluid each connector should be attached thereto.

## ENTERAL FEEDING SET

**[0001]** The present invention relates to an enteral feeding set and in particular an enteral feeding set for connection to an automatic pump system wherein a fluid to be supplied to a patient is automatically selectable from one of two fluid sources.

**[0002]** Feeding sets with more than one connection to a fluid source are known. For example, Tyco Healthcare has marketed an enteral feeding set (product code no. 717324) for connection to a pump having two tubes from two connectors leading to a single Y-connection. Each of the tubes may be individually clamped shut.

**[0003]** An enteral feeding set incorporating two fluid sources is shown in WO 2005/115501. This document teaches the use of a flow control apparatus which controls the operation of a valve for selecting one of the fluid sources for fluid supply to a patient.

**[0004]** Another arrangement incorporating two fluid sources is described in WO 98/046293.

**[0005]** A wide variety of connectors for connecting enteral feeding sets to fluid sources are known. Examples include a sliding seal adapter described in WO 2004/017852 and a connector including a spike for piercing a foil seal described in EP 1 063 956.

**[0006]** It is desirable to provide an enteral feeding set for connection to two different fluid sources in a manner such that a correct correction of a fluid source can be more reliably made.

## SUMMARY OF THE INVENTION

**[0007]** In one aspect of the present invention, there is provided an enteral feeding set comprising: first and second containers of fluid, each having a connection end, tubing adapted for fluid flow therethrough and further adapted to be engaged by a pump unit, a valve mechanism in direct communication with the tubing, the valve mechanism being adapted to be engaged by the pump unit, and a feeding set indicator for permitting identification of the functional configuration of the administration feeding set by the pump unit, wherein the tubing

comprises first and second inlet tubes on an upstream side of the valve mechanism and a single outlet tube on a downstream side thereof, wherein the first inlet tube includes a first connector for connecting the tube to the first container of fluid at the connection end thereof, and wherein the second inlet tube includes a second connector for connecting the tube to the second container of fluid at the connection end thereof, each of the first and second connectors being of like form but visually distinguishable for indicating to a user which container of fluid each connector should be attached thereto, wherein at least a portion of the first connector and at least a portion of the first container of fluid has a first colour for colour coding the first connector and the first container of fluid to indicate to the user that the first connector should be attached to the first container of fluid, wherein at least a portion of the second connector and at least a portion of the second container of fluid has a second colour for colour coding the second connector and the second container of fluid to indicate to the user that the second connector should be attached to the second container of fluid, the second colour being visually distinguishable from the first colour.

**[0008]** The present disclosure also discloses an enteral feeding set comprising: first and second containers of fluid, each having a connection end, tubing adapted for fluid flow therethrough and further adapted to be engaged by a pump unit, a valve mechanism in direct communication with the tubing, the valve mechanism being adapted to be engaged by the pump unit, and a feeding set indicator for permitting identification of the functional configuration of the administration feeding set by the pump unit, characterized in that the tubing comprises first and second inlet tubes on an upstream side of the valve mechanism and a single outlet tube on a downstream side thereof, wherein the first inlet tube includes a first connector for connecting the tube to the first container of fluid at the connection end thereof, and wherein the second inlet tube includes a second connector for connecting the tube to the second container of fluid at the connection end thereof, each of the first and second connectors being of like form but

visually distinguishable for indicating to a user which container of fluid each connector should be attached thereto, wherein at least a portion of the first connector and at least a portion of the first container of fluid has a first colour for colour coding the first connector and the first container of fluid to indicate to the user that the first connector should be attached to the first container of fluid, wherein at least a portion of the second connector and at least a portion of the second container of fluid has a second colour for colour coding the second connector and the second container of fluid to indicate to the user that the second connector should be attached to the second container of fluid, the second colour being visually distinguishable from the first colour.

[0009] The present disclosure further discloses an enteral feeding set comprising: a flush connector adapted to be coupled to a flush container holding a flush fluid therein, the flush connector comprising a first connector body, and a first liquid passage defined in the first connector body, the first liquid passage being in fluid communication with the flush container when the flush connector is coupled to the flush container, the first connector body further comprising a first spike extending outward for piercing a puncturable seal within the flush container, and a first air passage defined in the first connector body, the first air passage being coupled in fluid communication with the flush container for introducing air into the flush container; flush tubing coupled in fluid communication to the first liquid passage for receiving a flow of the flush fluid from the flush container; a feed connector adapted to be coupled to a feed container holding an enteral feed fluid therein, the feed connector comprising a second connector body, and a second liquid passage defined in the second connector body, the second liquid passage being in fluid communication with the feed container when the feed connector is coupled to the feed container, the second connector body further comprising a second spike extending outward for piercing a puncturable seal within the feed container, and a second air passage defined in the second connector body, the second air passage being coupled in fluid

communication with the feed container for introducing air into the feed container; feed tubing coupled in fluid communication to the second liquid passage for receiving a flow of the enteral feed fluid from the feed container; and a valve having first and second inlets coupled in fluid communication with the feed and flush tubing, respectively, and a valve outlet, the valve being selectively operable to allow and block flow through the valve outlet; wherein the first connector body and the second connector body are of like form but visually distinguishable for indicating to a user which supply of fluid each connector body should be attached thereto, wherein the first and second connector bodies being visually distinguishable for indicating to a user which supply of fluid each connector body should be attached thereto, is achieved by colour coding at least a portion of at least one of the connector bodies and colour coding at least a portion of the respective supply of fluid.

[0010] The present disclosure also discloses an enteral feed set comprising a generally flexible flush bag adapted to hold a flush fluid therein; the flush tubing coupled in fluid communication with the flexible flush bag for receiving a flow of the flush fluid therefrom; a feed connector adapted to be coupled to a feed container holding an enteral feed fluid therein, the feed connector comprising a connector body, and a liquid passage defined in the connector body, the liquid passage being in fluid communication with the feed container when the feed connector is coupled to the feed container, the connector body further comprising a spike extending outward for piercing a puncturable seal within the feed container, and an air passage defined in the connector body, the air passage being coupled in fluid communication with the feed container for introducing air into the feed container; feed tubing coupled in fluid communication to the liquid passage of the feed connector for receiving a flow of the enteral feed fluid from the feed container; and a valve having first and second inlets coupled in fluid communication with the feed and flush tubing, respectively, and a valve outlet, the valve being selectively operable to allow and block flow through the valve outlet.

4a

## BRIEF INTRODUCTION TO THE DRAWINGS

[0011] Preferred embodiments of the present invention will now be described, by way of example only, with reference to the accompanying drawings in which:

[0012] Fig. 1 is a schematic illustration of an enteral feed set for connection to two fluid sources;

[0013] Fig. 2 is a perspective of a connector for connecting an enteral container of liquid nutrients to an enteral feeding tube;

[0014] Fig. 3 is a vertical section of the connector;

[0015] Fig. 4 is a vertical section of the connector snapped into to a small outlet container and attached to an enteral feeding tube;

[0016] Fig. 5 is a vertical section of the connector threaded onto a large outlet container and attached to an enteral feeding tube;

[0017] Fig. 6 is fragmentary exploded perspective of the large outlet container, the connector and the enteral feeding tube;

[0018] Fig. 7 is a bottom plan view of the connector;

[0019] Fig. 8 is a front elevation of the connector with a portion of a body of the connector broken away to reveal a spike of the connector;

[0020] Fig. 9 is a side elevation of the connector with a portion of the body of the connector broken away to reveal the spike;

[0021] Fig. 10 is a side elevation of the connector with an air filter exploded from the connector and a mount for the filter partially broken to illustrate internal;

[0022] Fig. 11 is a schematic illustration of a second enteral feeding set;

[0023] Fig. 12 shows a sliding seal connector; and

[0024] Fig. 13 is a schematic illustration of a third enteral feeding set.

## DETAILED DESCRIPTION OF THE PREFERRED EMBODIMENTS

[0025] Fig. 1 shows an enteral feeding set 2 having two tubes 4, 6 for connection to respective fluid sources 8, 9 by means of respective connectors 10.

[0026] Referring now to Figs. 2-3, the connector 10 is shown in more detail. The connector includes a body, generally indicated at 12, having an interior surface 14 (Fig. 3) that defines a cavity 16 for receiving an outlet of the container, as explained in more detail below (Figs. 4-6). The body 12 has a cylindrical lower portion 18 and a smaller cylindrical upper portion 20 projecting upward from a top surface 22 of the lower portion.

[0027] Referring to Figs. 4-6, the cavity 16 is configured for receiving different types of containers. As shown in Fig. 4, the cavity 16 at the upper portion 20 is sized and shaped for snap-fit reception of a relatively small outlet 24 of a container 26. The interior surface 14 at the upper portion 20 is elastically deformable to allow a rigid snap-fit member 27 (e.g., a projecting rim extending around the outlet 24) to snap-fit into the upper portion.

[0028] As shown in Fig. 5, the cavity 16 at the lower portion 18 is sized and shaped to threadably receive a relatively larger outlet 28 of a container 30. The interior surface 14 at the lower portion 18 of the connector 10 includes internally projecting threads 32 for attaching to external threads 33 extending around the outlet 28 of the container 30. The depth D (Fig. 3) of the cavity 16 at the lower portion 18 is between about 1.40 cm and 1.80 cm. This depth D allows the connector 10 to attach to containers 30 having necks of different sizes and accommodates a more secure connection with the different containers. Further, the internal threads 32 of the lower portion 18 have a thickness  $T_1$  of between about 0.12cm and about 0.11cm. Ridges 34 (Fig. 2) disposed around an exterior surface of the body 12 at the lower portion 18 provide a user with adequate grip when threading the connector 10 on the container 30. The connector 10 may be configured to attach to an outlet of a container in other ways without departing from the scope of this invention. Moreover, the connector 10 may be configured to attach only to one type of container, such as a threaded container or a snap-fit container, or the connector may be configured to attach to more than two types of containers.

[0029] Referring to Figs. 3-5, a liquid passage 38 extends through the upper portion 20 of the body 12 and is in fluid communication with the cavity 16. An opening 40 of the liquid passage 38 is substantially flush with an upper surface section 42 of the interior surface 14 of the body 12 (i.e., the liquid passage does not extend into the cavity 16), although it is contemplated that the liquid passage may extend into the cavity. In the illustrated embodiment, the upper surface section 42 is substantially flat. The liquid passage 38 also extends through a conduit 44 projecting outward from the exterior surface

of the body 12 at the upper portion 20. The conduit 44 has externally projecting threads 46 for attaching to an internally threaded adapter 52 of an enteral feeding tube 54 (Figs. 4-6). The external threads 46 of the conduit 44 have a thickness  $T_2$  of between about 0.11cm and about 0.06cm. Other ways of connecting the enteral feeding tube 54 to the connector 10, including the use of an interference fitting, is within the scope of this invention.

**[0030]** As shown in Figs. 4-6, when assembled, the connector 10 is secured to the outlet 24, 28 of the respective container 26, 30 by either threading (as shown in Figs. 5 and 6) or fitting the connector on the container (Fig. 4). The threaded adapter 52 is threaded on the conduit 44 of the connector 10. Thus, when assembled, the connector 10 fluidly connects the enteral feeding tube 54 to the attached container 26, 30.

**[0031]** Referring to Figs. 3-8, a generally elongate spike, generally indicated at 58, formed integrally with the body 12 projects from the upper surface section 42 of the body into the cavity 16. The spike 58 is spaced a distance  $S_1$  (Fig. 3) from a central axis  $A_B$  of the body 12 and a distance  $S_2$  (Fig. 3) from a longitudinal axis  $A_O$  of the opening 40 of the liquid passage 38. The spike 58 is configured to puncture a puncturable seal 60 (e.g., foil seal) (Figs. 4-6) covering the outlet 24, 28 of the container 26, 30 to allow the liquid nutrients to exit the container. As shown best in Fig. 7, the spike 58 has a pair of opposite narrow sides 63A, 63B and a pair of opposite broad sides 63C, 63D extending between its length  $L_S$  (Fig. 8).

**[0032]** Referring to Figs. 7 and 8, a bottom surface 62 of the spike 58 (i.e., at the free end of the spike) is generally flat. As shown in Fig. 8, the bottom surface 62 is bevelled from the narrow side 63A (broadly, a first narrow side) to the opposite narrow side 63B (broadly, a second narrow side), such that the bottom surface lies in a plane intersecting the central axis  $A_B$  of the body 12 at an angle  $\Theta_1$ . This bevelled configuration of the bottom surface 62 forms a sharp tip 64 for puncturing the seal 60 of the threaded container 30. As shown in Fig. 8, the bottom surface 62 is also bevelled from the broad side 63C (broadly, a first broad side) to the opposite broad side 63D (broadly, a second broad side), such that the bottom surface lies in a plane intersecting the central axis of the body  $A_B$  at an angle  $\Theta_2$ .

**[0033]** Referring to Fig. 8, the narrow side 63B is bevelled from the broad side 63D to the opposite broad side 63C, defining a knife edge 66 along the length  $L_S$  of the spike to the tip 64. After the seal 60 is punctured by the tip 64, the knife edge 66 cuts the

seal 60 as the connector 10 is rotated (e.g., threaded) on the outlet 24, 28 of the container 26, 30. The spike 58 makes a relatively large (i.e., larger than the width of the spike 58), generally circular opening 70 through the seal, as illustrated in Figs. 4 and 5.

[0034] Referring to Figs. 7-9, the broad side 63D of the spike 58 is generally arcuate and joins the bevelled narrow side 63B at folding edge 68. The narrow side 63B tapers toward the bottom surface 62 such that the folding edge 68 falls off or angles toward the tip 64. As the connector 10 is rotated on the container 26, 30, the knife edge 66 cuts the seal 60 and forms a foil edge margin 69 (Figs. 3 and 4) defining the opening 70. Referring to Figs. 4 and 5, as the connector 10 continues to rotate, the folding edge 68 of the spike 58 folds the foil edge margin 69 of the seal 60 away from the opening 70 in the seal 60 and away from the opening 40 of the liquid passage 38 so that the foil edge margin will not obstruct the openings.

[0035] Referring to Figs. 3-5, an air passage 72 extends from the cavity 16 through the spike 58 and the upper portion 20 of the body 12. A vacuum within the container 26, 30, created when the liquid exits the container, draws air into the container through the air passage 72, thereby allowing the liquid to flow continuously and freely out of the container through the liquid passage 38 of the connector 10. The air passage 72 opens at the bottom surface 62 of the spike 58 to communicate with the cavity 16, although the passage may open at other locations along the length  $L_s$  of the spike.

[0036] Referring to Figs. 3-5 and 9, the air passage 72 is fluidly connected to a filter mount, generally indicated at 74, projecting outward from the exterior surface of the body 12 at the upper portion 20. The filter mount 74 includes a large cylindrical opening 76 (Fig. 3) having a longitudinal axis  $A_{CO}$  extending generally transverse to the central axis  $A_B$  of the body 12. A tubular duct 78 disposed within the large opening 76 extends generally coaxially therein. As shown in Fig. 3, the duct 78 has a first open end 80 in fluid communication with the air passage 72 and a second open end 82 terminating within the large opening 76. The large opening 76 and an exterior surface of the duct 78 define an annular socket 84 (Fig. 3) making an interference fit with a tubular end 86 of a filter 88 (Fig. 10) such that the filter is in fluid communication with the duct and the air passage 72 when fitted in the socket. As shown in Figs. 2, 4 and 5, when the air filter 88 is received in the filter mount 74, a filter medium 90 of the filter extends outside the mount.

**[0037]** The entire connector 10, excluding the air filter 88, may be formed as a homogeneous and integral unit, such as by molding (e.g., injection molding) or by forming, including boring, from stock material. Alternatively, the connector 10 may be constructed of one or more separate components fastened together in a suitable manner. Suitable materials for making the connector 10 include polypropylene (e.g., polypropylene 535), polyethylene and other suitable polymers. Other material may be used, and different material may be used for the separate components of the connector 10.

**[0038]** Referring again to Fig. 1, the connectors 10 are connected to first ends of respective tubes 4 and 6. These tubes are connected at their opposite ends to a valve unit 100 which also connects to a single tube 102 at a first end thereof. The tube 102 is attached to an automated peristaltic pump (not shown) which as well as controlling the pumping of fluid through the feeding set 2 operates the valve unit 100. A magnetic feed set identifier 104 is attached to a second end of the tube 102 and a further tube 106 leads therefrom for connection to a patient-indwelling gastrostomy device (not shown). Details of a suitable automated pump arrangement are described in WO 2005/115501.

**[0039]** Fluid sources are attachable to the connectors 10. In the preferred embodiment, fluid sources 8 and 9 may be connected, in which fluid source 8 contains a feeding solution and fluid source 9 contains a flushing solution.

**[0040]** In view of the automated operation of the pump, it is important that an operator correctly connects the fluid sources to the feed set in order that the automatic pump controls the valve appropriately. In order to ensure correct matching of a particular connector 10 to a particular fluid source, in the preferred embodiment, the connectors are colour coded such that a colour of the plastic molding of the body 12 of the connector corresponds to a colour of the fluid source container, whereby the container may, for example, be appropriately coloured by colouring a screw fitting molding to which the connector 10 is attached or by a coloured foil around the fluid container. Rather than colouring the connector 10, a coloured flag could be attached to the appropriate tube 4 and 6 for matching with an appropriate coloured container. The connectors may therefore be of like form but visually distinguishable for indicating to an operator which supply of fluid each connector should be attached to.

8a

[0041] Another solution for providing an improved enteral feeding set is an arrangement as shown in Fig. 11. In the arrangement of Fig. 11, rather than the connectors 10 of the Fig. 1 arrangement, the enteral feeding set 202 shown in Fig. 11 includes two

sliding seal connectors 210. The sliding seal connectors 210 are fabricated in accordance with the arrangement shown in WO 2004/017852. An expanded view of one of the connectors 210 is shown in Fig. 12. As in the case of the feeding set 2, the feeding set 202 provides means for correctly matching up a respective connector 210 to a respective fluid source. The preferred means in the case of the arrangement shown in Fig. 11 is to colour code one of the components forming the connector, for example a body portion 220. Of course, a coloured flag arrangement could also be used, as with the arrangement of Fig. 1. The connectors may therefore also be of like form but visually distinguishable for indicating to an operator which supply of fluid each connector should be attached to.

**[0042]** A still further solution for providing an improved enteral feeding set is an arrangement as shown in Fig. 13. In this arrangement, the enteral feeding set 302 incorporates a single connector 10 in accordance with the connector shown in Figs. 2-10 attached to one tube 306. Second tube 308 terminates in a permanent connection to a refillable fluid bag 310. By providing two different fluid sources, one a rigid container containing a feeding solution and a refillable bag for receiving a flushing solution, the arrangement of Fig. 13 provides an enhanced degree of security that the correct fluid solution will be provided to the correct connection tube.

**[0043]** When introducing elements of the present invention or the preferred embodiment(s) thereof, the articles “a”, “an”, “the” and “said” are intended to mean that there are one or more of the elements. The terms “comprising”, “including” and “having” are intended to be inclusive and mean that there may be additional elements other than the listed elements.

**[0044]** In view of the above, it will be seen that the several objects of the invention are achieved and other advantageous results attained.

**[0045]** As various changes could be made in the above constructions, products, and methods without departing from the scope of the invention, it is intended that all matter contained in the above description and shown in the accompanying drawings shall be interpreted as illustrative and not in a limiting sense.

## CLAIMS

1. An enteral feeding set comprising:  
first and second containers of fluid, each having a connection end,  
tubing adapted for fluid flow therethrough and further adapted to be engaged by  
a pump unit,  
a valve mechanism in direct communication with said tubing, said valve  
mechanism being adapted to be engaged by said pump unit, and  
a feeding set indicator for permitting identification of the functional  
configuration of said administration feeding set by said pump unit,  
wherein said tubing comprises first and second inlet tubes on an upstream side  
of said valve mechanism and a single outlet tube on a downstream side  
thereof, wherein said first inlet tube includes a first connector for connecting  
said tube to the first container of fluid at the connection end thereof, and  
wherein said second inlet tube includes a second connector for connecting  
said tube to the second container of fluid at the connection end thereof, each  
of said first and second connectors being of like form but visually  
distinguishable for indicating to a user which container of fluid each  
connector should be attached thereto,  
wherein at least a portion of the first connector and at least a portion of the first  
container of fluid has a first colour for colour coding the first connector and  
the first container of fluid to indicate to the user that the first connector  
should be attached to the first container of fluid,  
wherein at least a portion of the second connector and at least a portion of the  
second container of fluid has a second colour for colour coding the second  
connector and the second container of fluid to indicate to the user that the

second connector should be attached to the second container of fluid, the second colour being visually distinguishable from the first colour.

2. The enteral feeding set according to claim 1, wherein the first colour is non-removable from the first connector and the first container of fluid, and wherein the second colour is non-removable from the second connector and the second container of fluid.

3. The enteral feeding set according to claim 2, wherein the connection end of the first container includes a first fitting for connection with the first connector, the first fitting having the first colour, wherein the connection end of the second container includes a second fitting for connection with the second connector, the second fitting having the second colour.

4. The enteral feeding set according to any one of claims 1 to 3, wherein said first and second containers each comprises an outlet and a puncturable seal covering the outlet,

wherein said connectors each comprises:

a body having an interior surface defining a cavity for receiving the outlet of the corresponding container, and an exterior surface;

a liquid passage defined in the body having a first end in fluid communication with the cavity and a second end for fluid connection to the corresponding one of the first and second inlet tubes to fluidly connect the first and second containers and the corresponding one of the first and second inlet tubes when the connector is received on the container;

a spike formed integrally with the body and having a free end projecting into the cavity for piercing the puncturable seal covering the outlet of the corresponding one of the first and second containers as the outlet of the container is being received in the cavity;

an air passage extending through the spike to the exterior surface of the body for introducing air from outside the connector into the corresponding one of the first and second containers when the connector is attached to the container; and

the body being free of structure that both defines any portion of the liquid passage and is formed for penetrating the puncturable seal of the container.

5. The enteral feeding set according to any one of claims 1 to 3, wherein the interior surface of the body includes an upper surface section, the liquid passage having an opening generally flush with the upper surface section, and further wherein no portion of the liquid passage extends into the cavity.

6. The enteral feeding set according to claim 4 further comprising an air filter and a filter mount disposed on the exterior surface of the body in fluid communication with the air passage for connecting the air filter to the body.

7. The enteral feeding set according to claim 4 wherein the body has a cylindrical lower portion and a cylindrical upper portion projecting from the lower portion, the interior surface at the lower portion having internally projecting threads for threadably attaching to the corresponding one of the first and second containers with a threaded, larger diameter outlet, the interior surface at the upper portion being adapted for snap fitting to the corresponding one of the first and second containers with a smaller diameter outlet.

8. The enteral feeding set according to claim 4 wherein the spike has a generally flat bottom surface and the air passage opens at the flat bottom surface into the cavity.

9. The enteral feeding set according to claim 4 wherein the spike has first and second opposite broad sides, and first and second opposite narrow sides, the second narrow side being beveled from the second broad side to the first broad side, so that a cutting edge is formed where the second narrow side meets the first broad side, the second narrow side tapering toward the free end of the spike such that a folding edge is formed where the second narrow side meets the second broad side.

10. The enteral feeding set according to any one of claims 1 to 3, wherein each of the first and second connectors comprises an internally threaded body for attaching the connector to the corresponding one of the first and second containers, and a spike member arranged within said internally threaded body and attached to a body member slidably movable along a shaft seal.

11. The enteral feeding set according to any one of claims 1 to 3:  
wherein the first container comprises a generally flexible flush bag adapted to hold a flush fluid therein;  
wherein the first connector is attached to the flexible flush bag and the first inlet tube is in fluid communication with the flexible flush bag for receiving a flow of the flush fluid therefrom, said first inlet tube being a flush tubing;  
wherein the second container comprises a feed container holding an enteral feed fluid therein, the feed container including a puncturable seal,  
wherein the second connector comprises a feed connector connected to the feed container, the feed connector comprising a connector body, and a liquid passage defined in the connector body, the liquid passage being in fluid communication with the feed container, the connector body further comprising a spike extending outward and piercing the puncturable seal of

the feed container, and an air passage defined in the connector body, the air passage being coupled in fluid communication with the feed container for introducing air into the feed container;

wherein the second inlet tube is in fluid communication with the liquid passage of the feed connector for receiving a flow of the enteral feed fluid from the feed container; and

wherein the valve mechanism has first and second inlets coupled in fluid communication with the first and second inlet tubes, respectively, and a valve outlet in communication with the single outlet tube, the valve being selectively operable to connect the first inlet tube in fluid communication with the single outlet tube and connect the second inlet tube in fluid communication with the single outlet tube.

12. The enteral feeding set of claim 11, wherein the connector body of the feed connector includes a cavity, a base, and said air passage, and wherein the air passage extends upward from the base into the cavity.

13. The enteral feeding set of claim 12, wherein the air passage is spaced apart from the spike along an interior surface of the connector body of the feed connector.

14. The enteral feeding set of claim 12, wherein the spike is located along the base adjacent to the liquid passage and remote from the stem.

15. The enteral feeding set of claim 12, wherein the air passage has an outer end located within the cavity, the outer end of the stem receiving a filter.

16. The enteral feeding set of claim 12, wherein the connector body of the feed connector includes a connection portion adapted to be connected to the feed container, the liquid passage extends through the base and comprises an inlet for receiving fluid from the cavity, and the air passage extends toward the connection portion from an end coupled to the base to a free end located within the cavity, wherein the free end is closer to the connection portion than the liquid passage inlet.

17. The enteral feeding set of claim 11, wherein the feed connector is threadably connected to the feed container.

18. The enteral feeding set of claim 11, wherein the feed container comprises a generally rigid container.

19. The enteral feeding set of claim 11, wherein the feed container comprises a generally flexible bag.

20. The enteral feeding set of claim 11, further comprising a pump tube coupled in fluid communication with the valve outlet, the pump tube being adapted to be acted upon to pump fluid received from the valve through the pump tube.

1 / 13

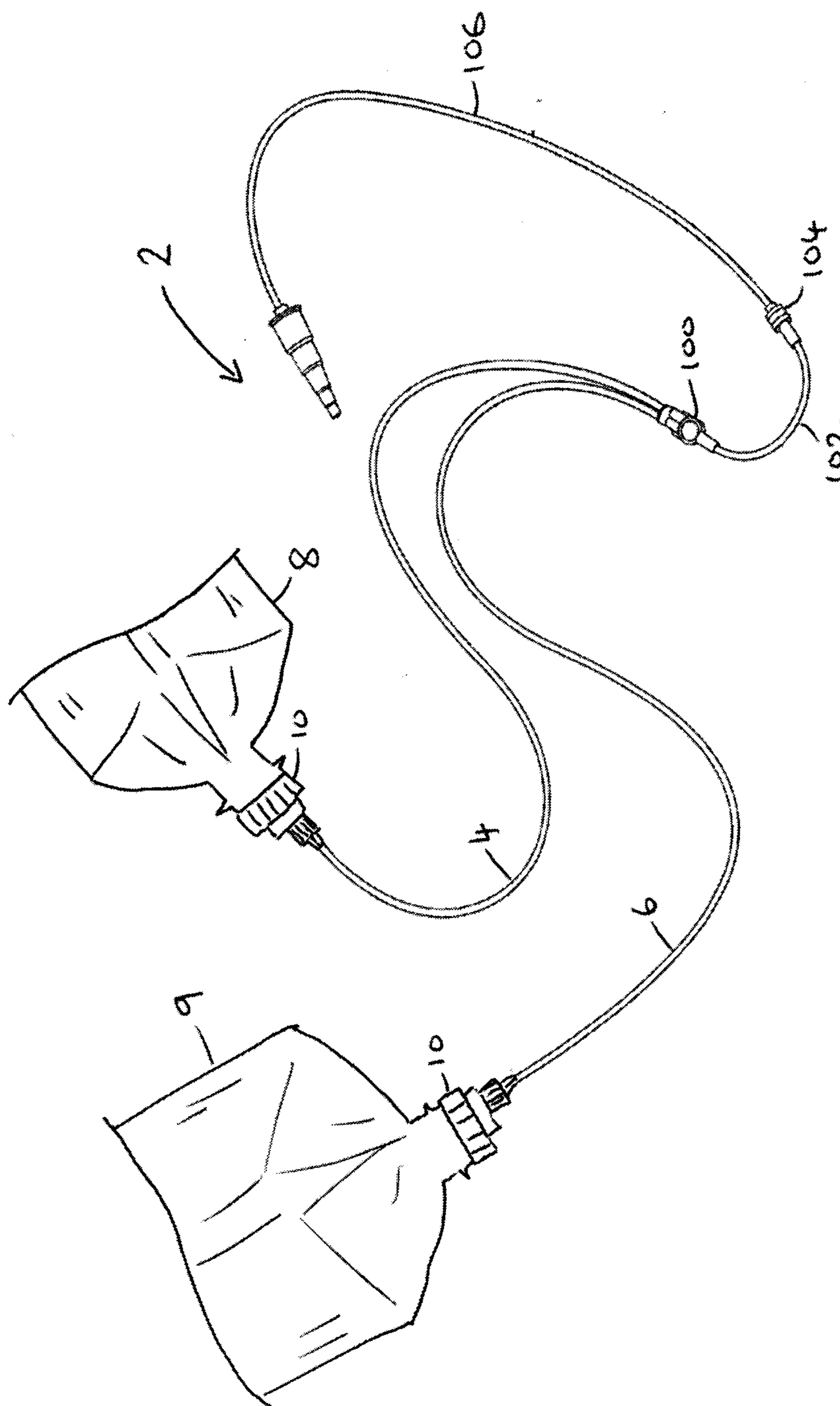

Fig. 1

2 / 13

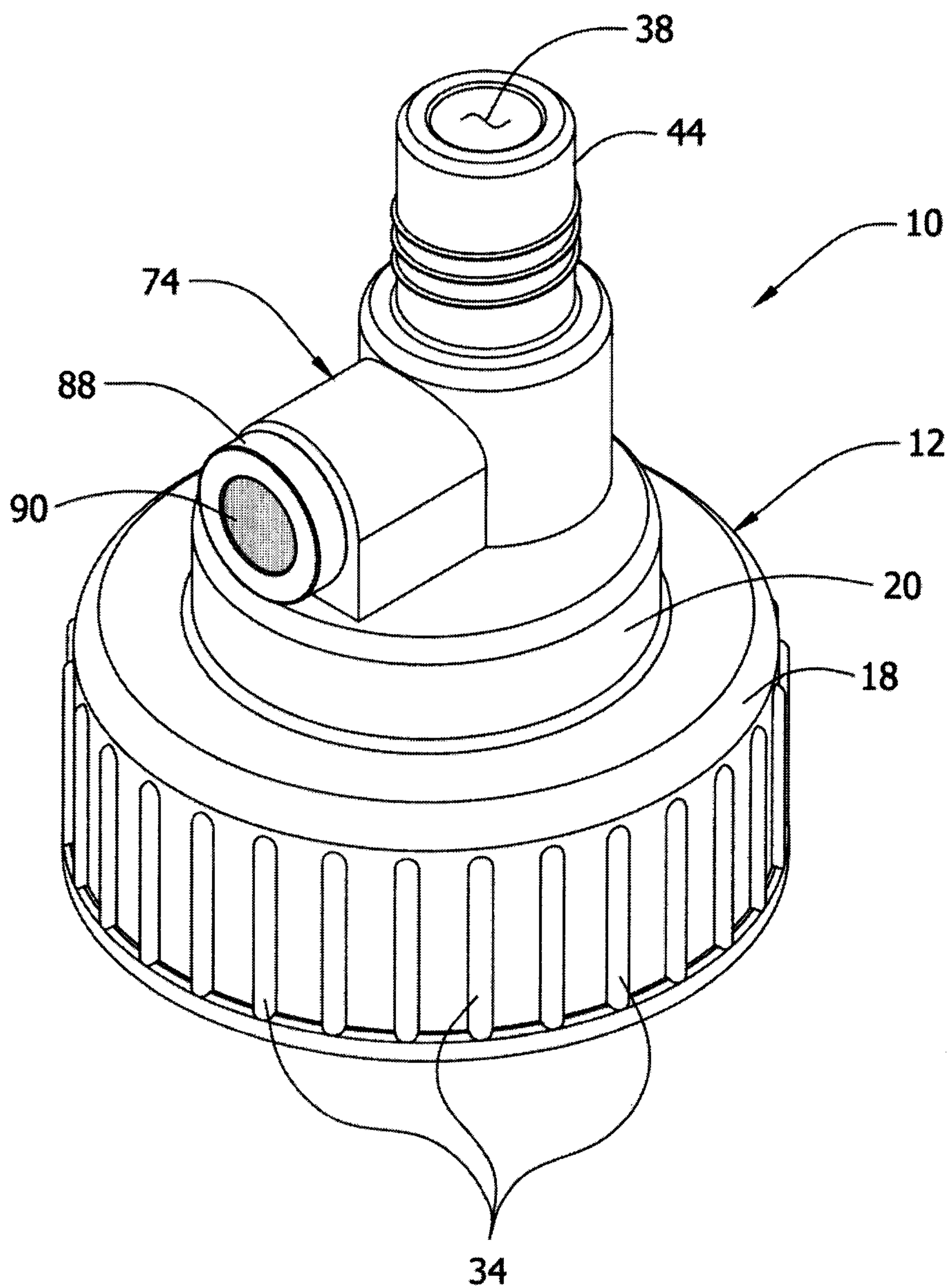
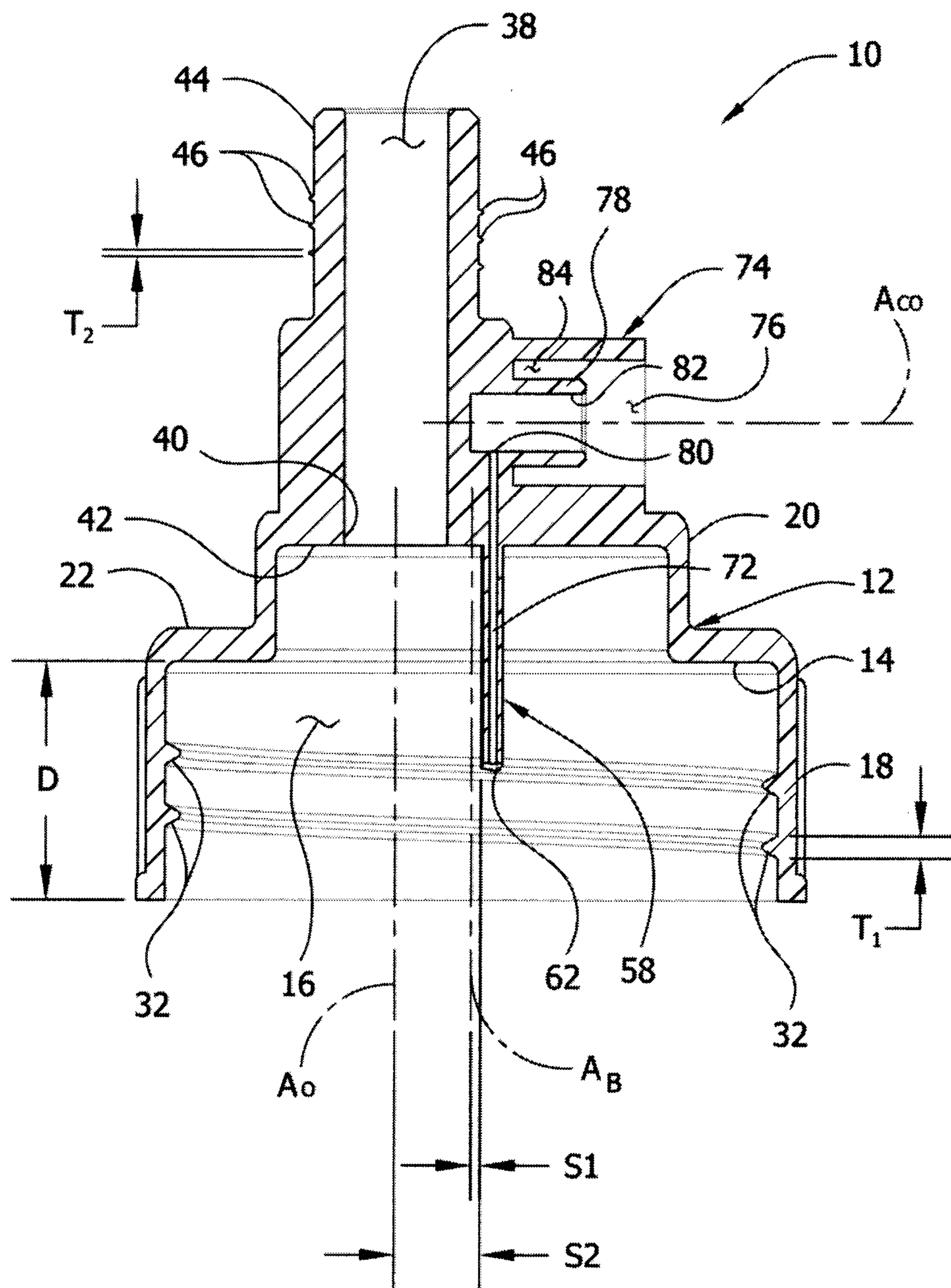

Fig. 2

3 / 13



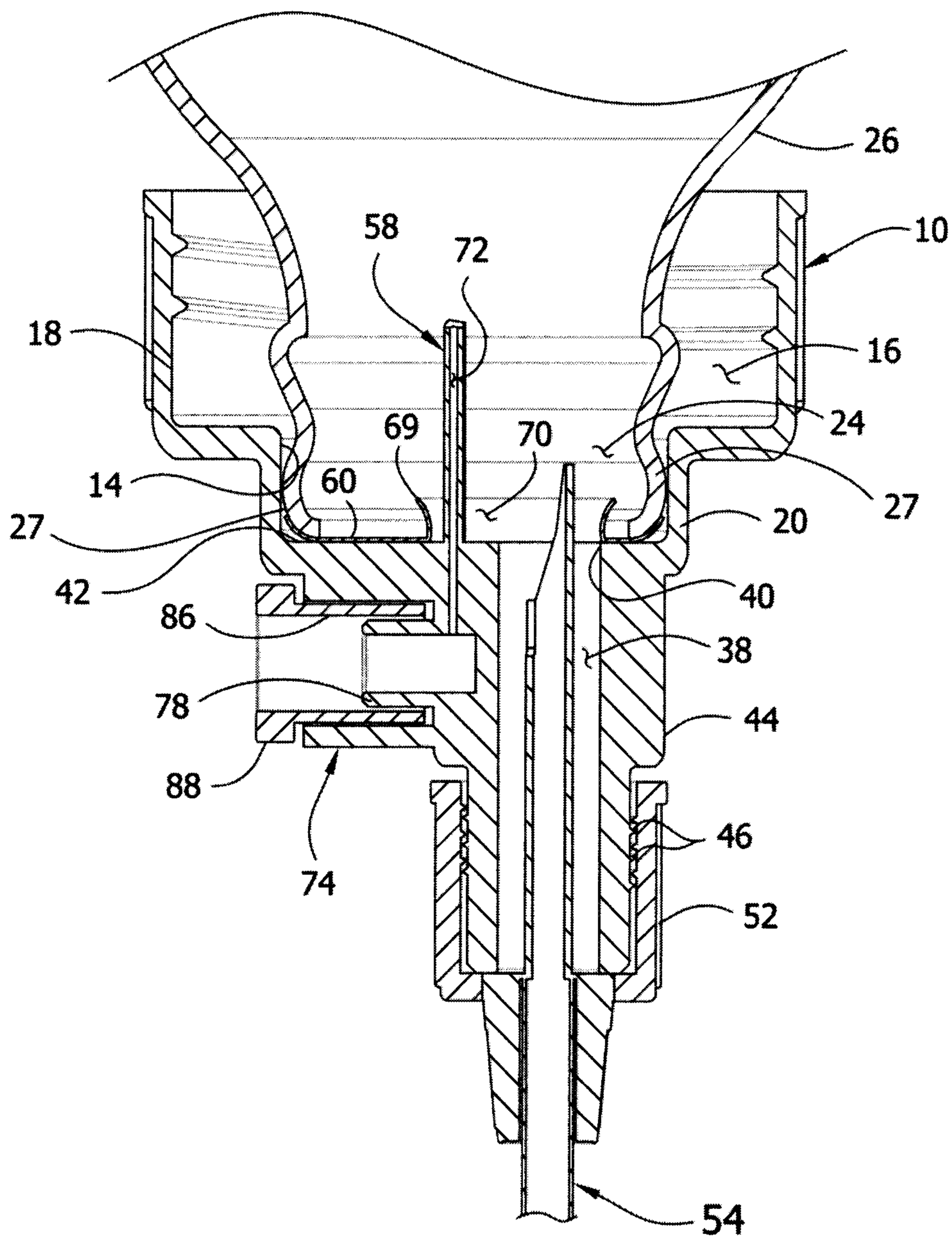

Fig. 4



6 / 13

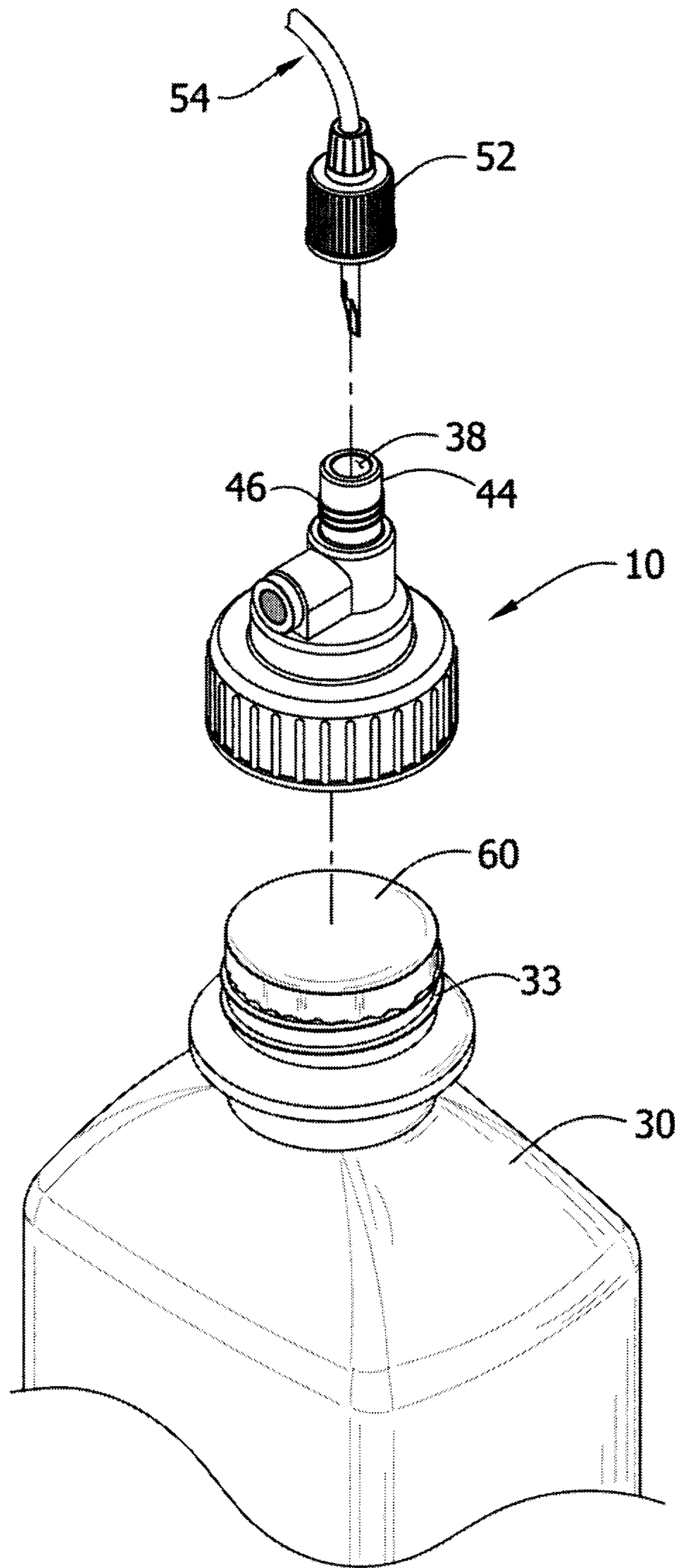

Fig. 6

7 / 13

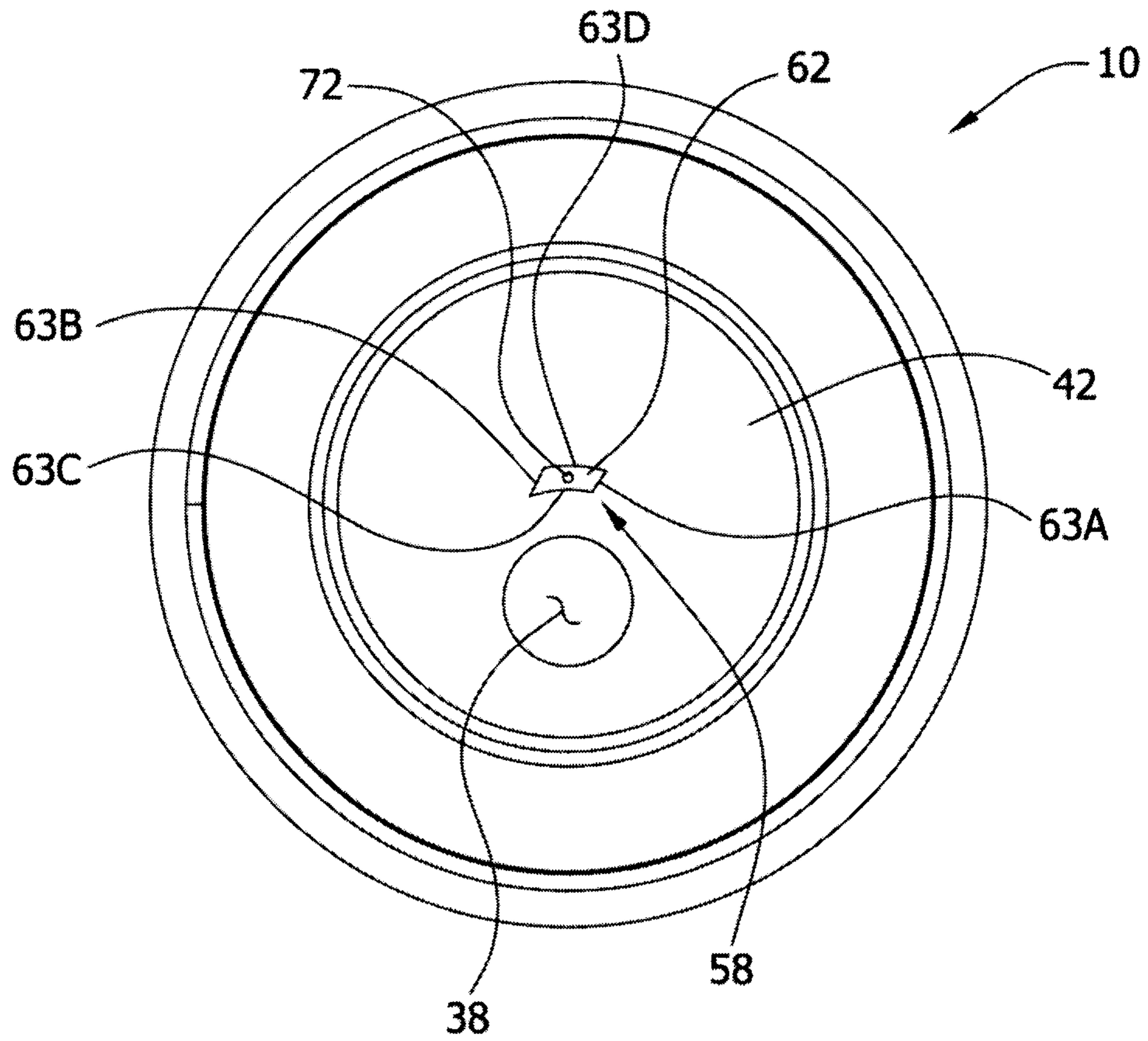

Fig. 7

8 / 13

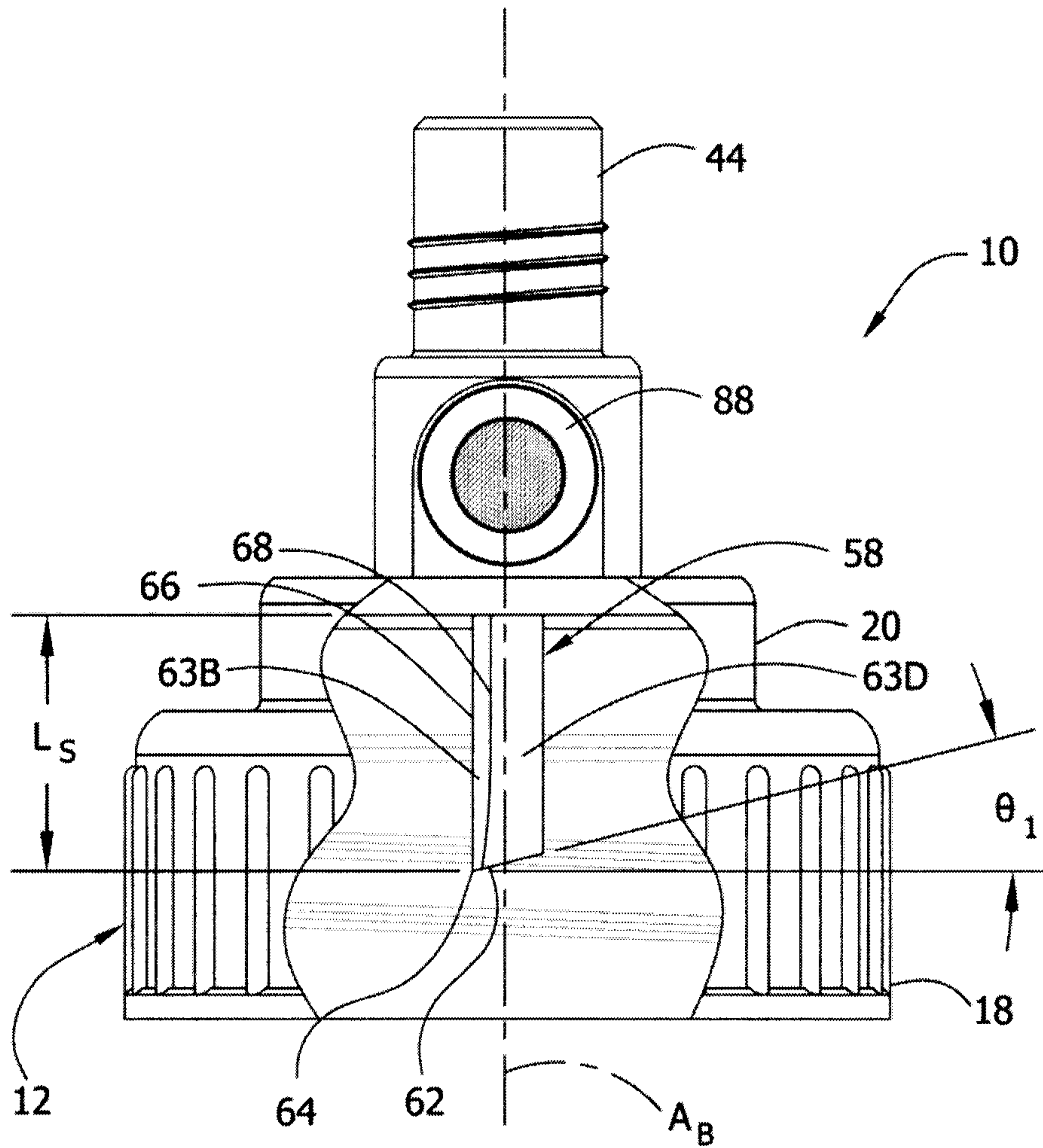

Fig. 8

9 / 13

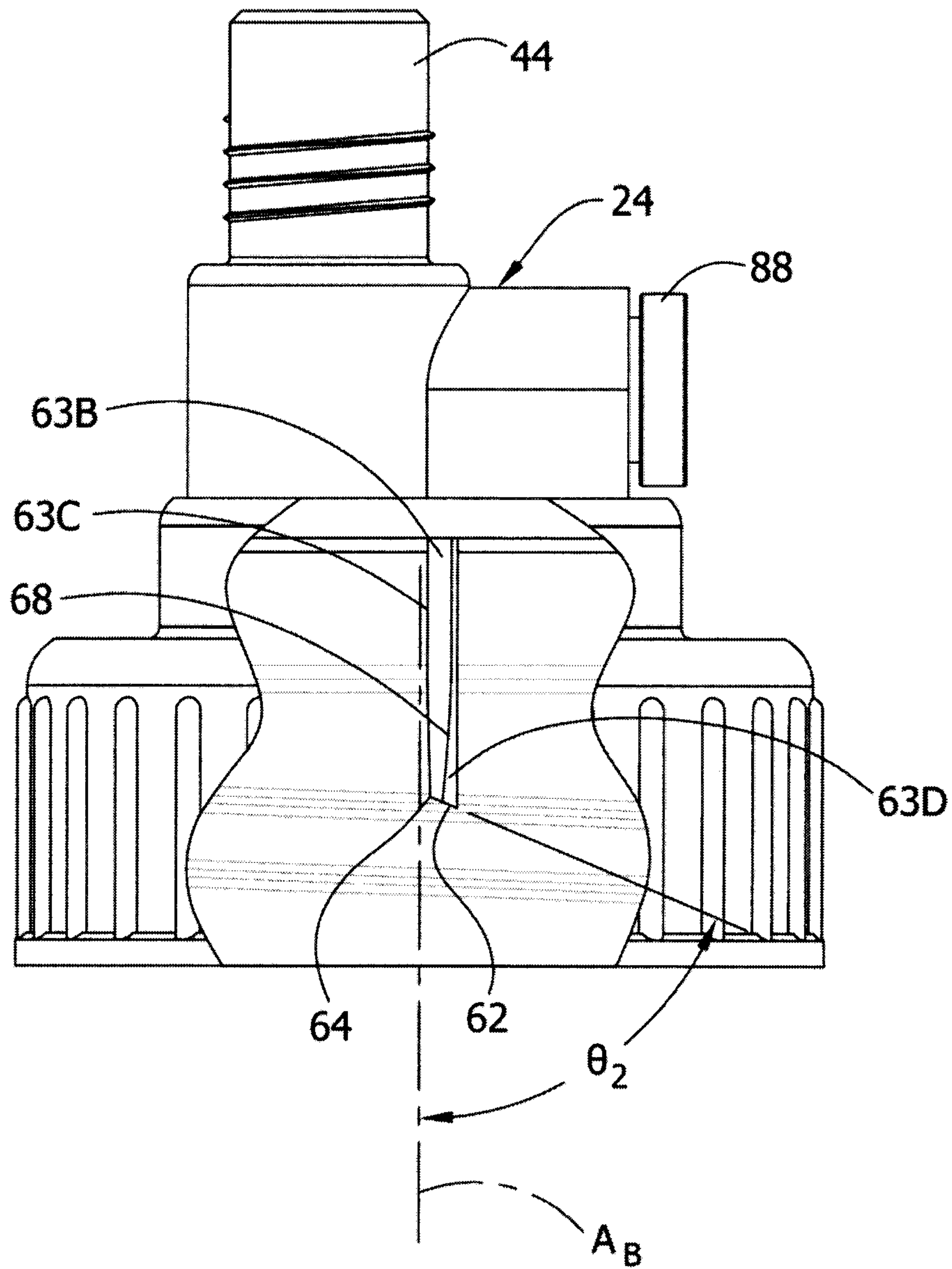

Fig. 9

10 / 13

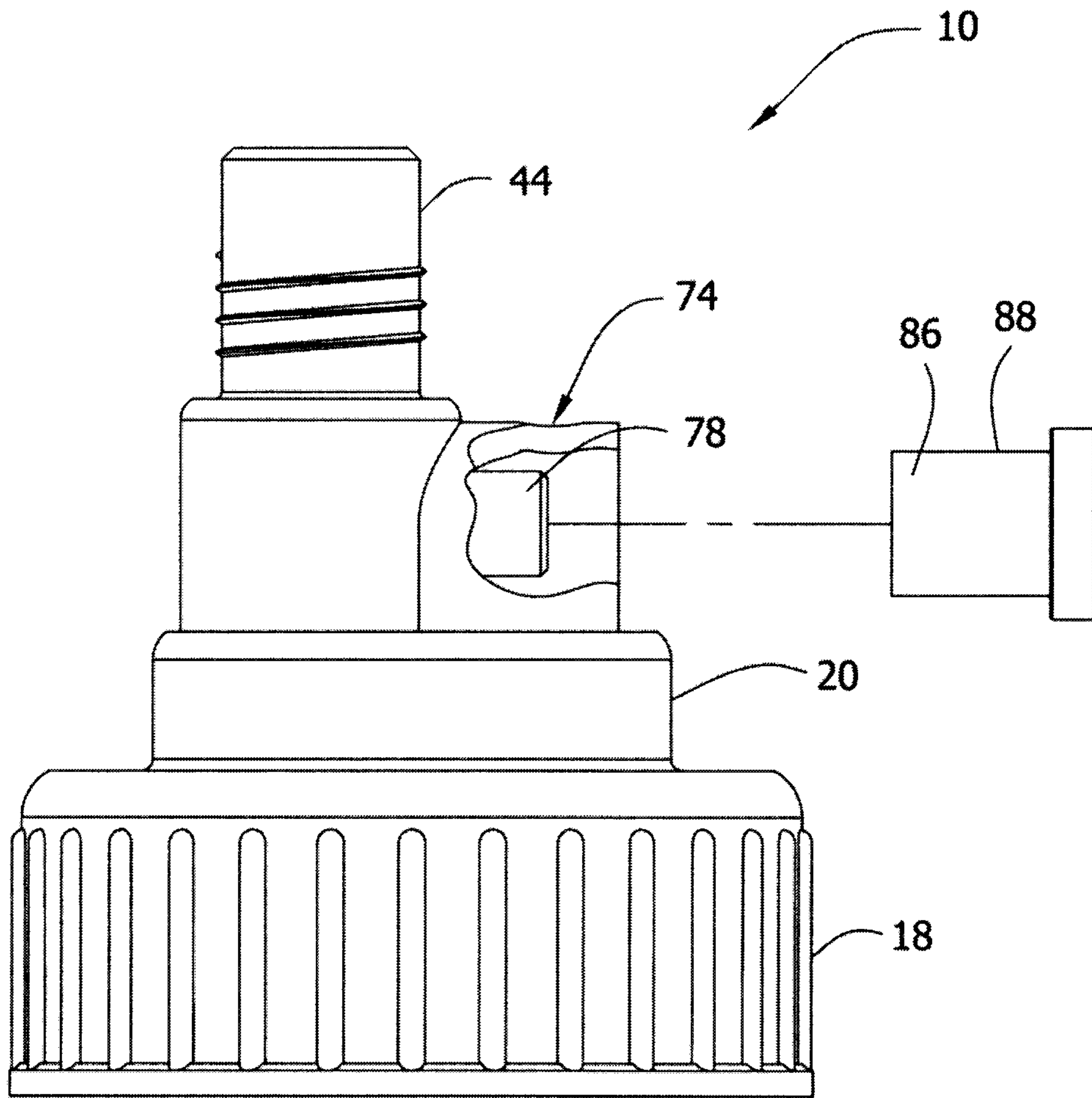

Fig. 10

11 / 13

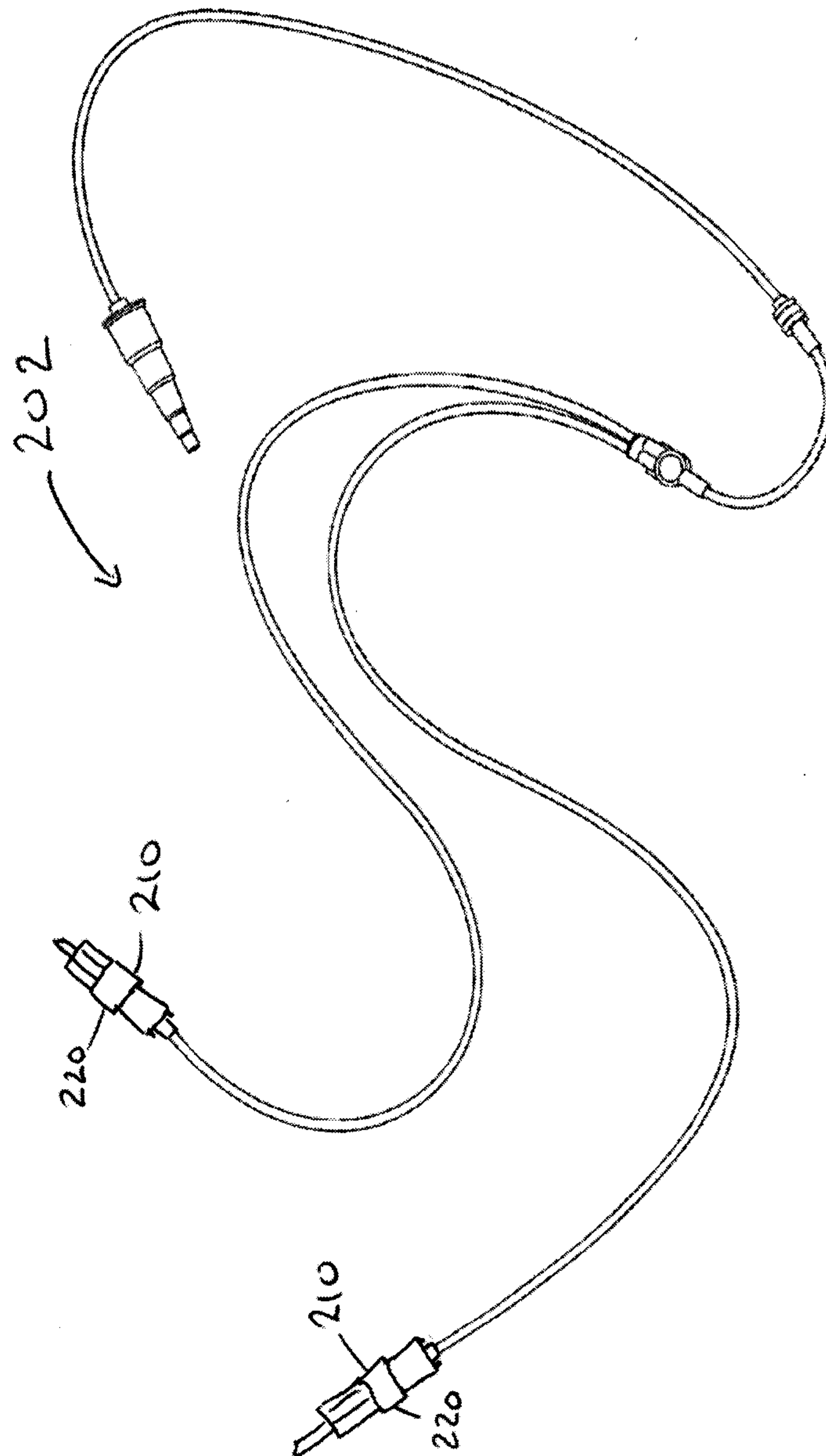

Fig. 11

12 / 13

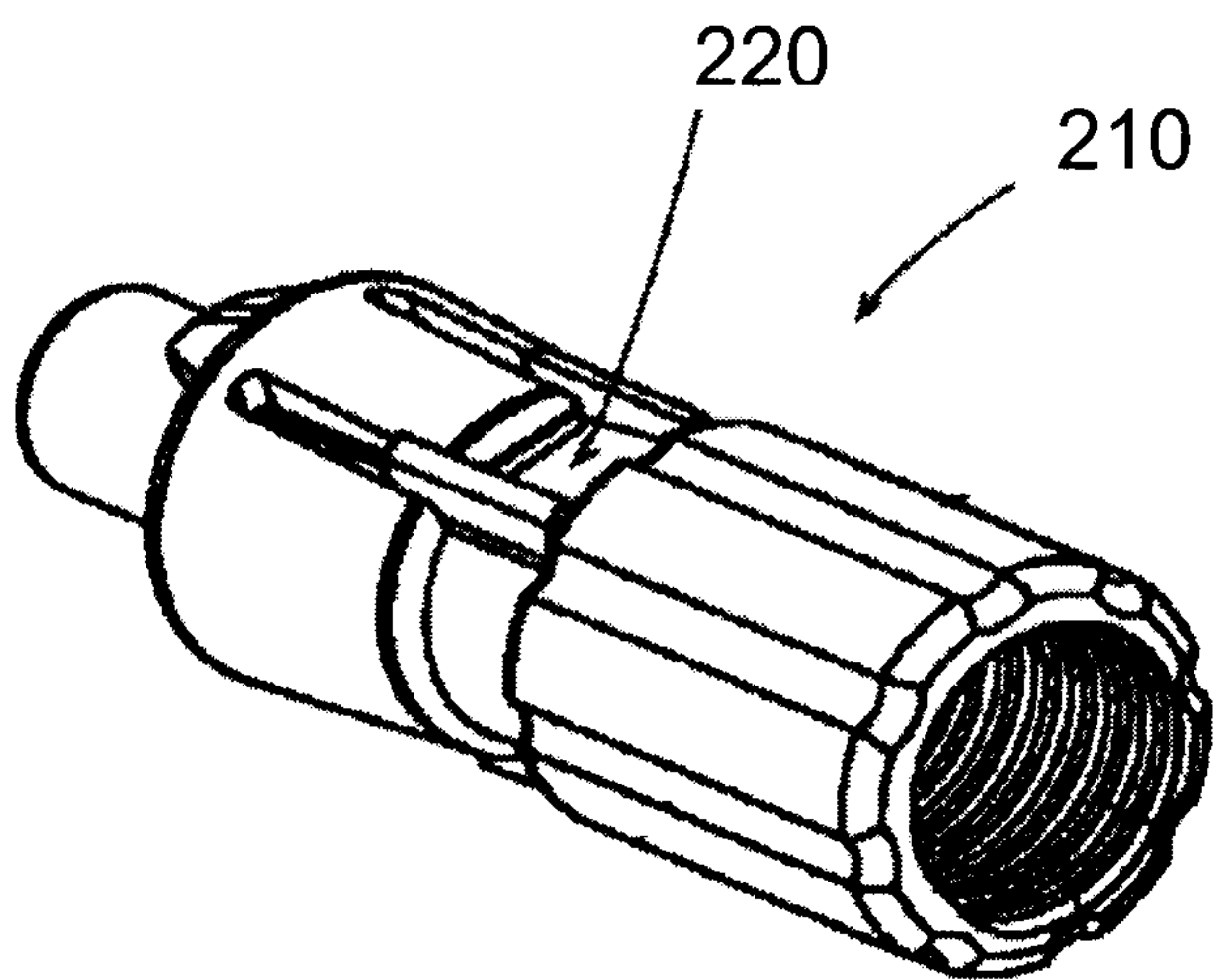

Fig. 12

13 / 13

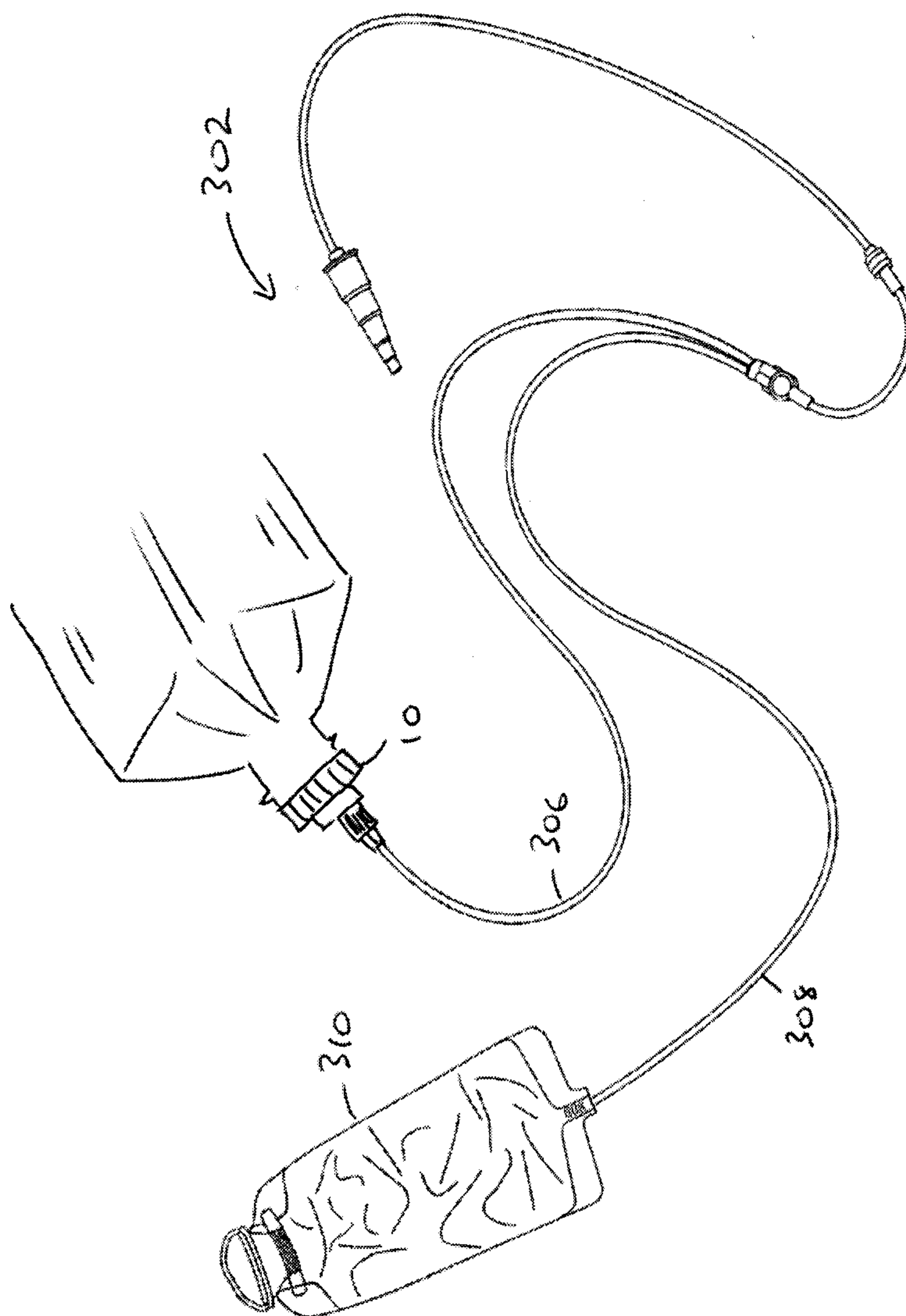

Fig. 13

