

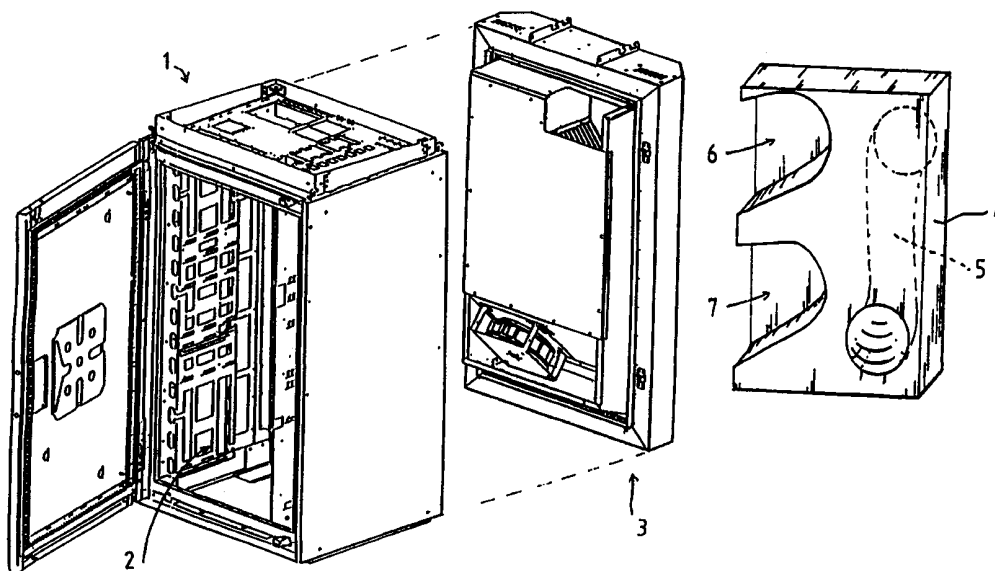

INTERNATIONAL APPLICATION PUBLISHED UNDER THE PATENT COOPERATION TREATY (PCT)

<p>(51) International Patent Classification⁶ : H05K 7/20</p>	<p>A1</p>	<p>(11) International Publication Number: WO 99/18763</p> <p>(43) International Publication Date: 15 April 1999 (15.04.99)</p>
<p>(21) International Application Number: PCT/FI98/00742</p> <p>(22) International Filing Date: 22 September 1998 (22.09.98)</p> <p>(30) Priority Data: 973881 3 October 1997 (03.10.97) FI</p> <p>(71) Applicant (for all designated States except US): NOKIA TELECOMMUNICATIONS OY [FI/FI]; Keilalahdentie 4, FIN-02150 Espoo (FI).</p> <p>(72) Inventors; and (75) Inventors/Applicants (for US only): TAKALA, Roope [FI/FI]; Sateentie 2 A 31, FIN-02100 Espoo (FI). UUSITALO, Petri [FI/FI]; Radiomastontie 1 A 3, FIN-90230 Oulu (FI). PERRY, Malcolm [GB/GB]; 1 Suddern Farm Cottages, Salisbury Lane, Over Wallop, Stockbridge, Hants SO20 8JJ (GB).</p> <p>(74) Agent: PAPULA REIN LAHTELA OY; Fredrikinkatu 61 A, P.O. Box 981, FIN-00101 Helsinki (FI).</p>		<p>(81) Designated States: AL, AM, AT, AU, AZ, BA, BB, BG, BR, BY, CA, CH, CN, CU, CZ, DE, DK, EE, ES, FI, GB, GE, GH, GM, HR, HU, ID, IL, IS, JP, KE, KG, KP, KR, KZ, LC, LK, LR, LS, LT, LU, LV, MD, MG, MK, MN, MW, MX, NO, NZ, PL, PT, RO, RU, SD, SE, SG, SI, SK, SL, TJ, TM, TR, TT, UA, UG, US, UZ, VN, YU, ZW, ARIPO patent (GH, GM, KE, LS, MW, SD, SZ, UG, ZW), Eurasian patent (AM, AZ, BY, KG, KZ, MD, RU, TJ, TM), European patent (AT, BE, CH, CY, DE, DK, ES, FI, FR, GB, GR, IE, IT, LU, MC, NL, PT, SE), OAPI patent (BF, BJ, CF, CG, CI, CM, GA, GN, GW, ML, MR, NE, SN, TD, TG).</p> <p>Published <i>With international search report.</i> <i>Before the expiration of the time limit for amending the claims and to be republished in the event of the receipt of amendments.</i></p>

(54) Title: ELECTRONICS CABINET AND AIR CHANNEL SYSTEM FOR AN ELECTRONICS CABINET



(57) Abstract

Electronics cabinet comprising an enclosure (1) with an interior space (2) where electronic parts, such as circuit cards and the like, can be mounted, and a cooling system (3) arranged as a substantially integral assembly with the enclosure in the immediate vicinity of its interior space for cooling the interior space. The cooling system (3) comprises means for internal air circulation within the interior space, for conveying an external air circulation separated from the internal air circulation into and out of the cooling system and for cooling the air in the internal circulation. The means for conveying the internal and/or external air circulation comprise a body (4) made from a foamed material with a flow channel (5, 6, 7) formed in it, through which at least part of the internal and/or external air circulation is passed.

FOR THE PURPOSES OF INFORMATION ONLY

Codes used to identify States party to the PCT on the front pages of pamphlets publishing international applications under the PCT.

AL	Albania	ES	Spain	LS	Lesotho	SI	Slovenia
AM	Armenia	FI	Finland	LT	Lithuania	SK	Slovakia
AT	Austria	FR	France	LU	Luxembourg	SN	Senegal
AU	Australia	GA	Gabon	LV	Latvia	SZ	Swaziland
AZ	Azerbaijan	GB	United Kingdom	MC	Monaco	TD	Chad
BA	Bosnia and Herzegovina	GE	Georgia	MD	Republic of Moldova	TG	Togo
BB	Barbados	GH	Ghana	MG	Madagascar	TJ	Tajikistan
BE	Belgium	GN	Guinea	MK	The former Yugoslav Republic of Macedonia	TM	Turkmenistan
BF	Burkina Faso	GR	Greece	ML	Mali	TR	Turkey
BG	Bulgaria	HU	Hungary	MN	Mongolia	TT	Trinidad and Tobago
BJ	Benin	IE	Ireland	MR	Mauritania	UA	Ukraine
BR	Brazil	IL	Israel	MW	Malawi	UG	Uganda
BY	Belarus	IS	Iceland	MX	Mexico	US	United States of America
CA	Canada	IT	Italy	NE	Niger	UZ	Uzbekistan
CF	Central African Republic	JP	Japan	NL	Netherlands	VN	Viet Nam
CG	Congo	KE	Kenya	NO	Norway	YU	Yugoslavia
CH	Switzerland	KG	Kyrgyzstan	NZ	New Zealand	ZW	Zimbabwe
CI	Côte d'Ivoire	KP	Democratic People's Republic of Korea	PL	Poland		
CM	Cameroon	KR	Republic of Korea	PT	Portugal		
CN	China	KZ	Kazakstan	RO	Romania		
CU	Cuba	LC	Saint Lucia	RU	Russian Federation		
CZ	Czech Republic	LI	Liechtenstein	SD	Sudan		
DE	Germany	LK	Sri Lanka	SE	Sweden		
DK	Denmark	LR	Liberia	SG	Singapore		
EE	Estonia						

ELECTRONICS CABINET AND AIR CHANNEL SYSTEM FOR AN
ELECTRONICS CABINET

The present invention relates to an electronics cabinet as defined in the preamble of claim 1.
5 Moreover, the invention relates to an air channel system for an electronics cabinet as defined in the preamble of claim 10.

In prior art, an electronics cabinet is known which comprises an enclosure with an interior space
10 where electronic parts, such as circuit cards and the like, can be mounted. The cabinet is also provided with a cooling system for cooling the space inside the cabinet. The cooling system is an integral assembly attached to the enclosure in the immediate vicinity of
15 its interior space. The cooling system comprises means for internal air circulation within the interior space, for conveying an external air circulation separated from the internal air circulation into and out of the cooling system and for cooling the internal
20 circulation air by means of the external air circulation. In this prior-art electronics cabinet, the means for conveying the air consist of a complex sheet metal structure comprising several bent sheet metal parts, in which the air flow channels are formed from a large
25 number of bent sheet metal parts joined together. To damp the noise generated by the air flow, the sheet metal structure is additionally lined with foamed plastic panels. A problem with this prior-art structure is that its manufacturing costs are very high due
30 to the complexity of the structure.

The object of the present invention is to eliminate the drawbacks mentioned above.

A specific object of the invention is to present an electronics cabinet and an air channel system
35 for the cabinet that are simple in structure as well as cheap and allow easy assembly of the unit.

The electronics cabinet of the invention is characterised by what is presented in claim 1. The air channel system for an electronics cabinet according to the invention is characterised by what is presented in
5 claim 10.

The electronics cabinet of the invention comprises an enclosure with an interior space where electronic parts, such as circuit cards and the like, can be mounted, and a cooling system implemented as a substantially integral assembly with the enclosure and disposed in the immediate vicinity of the interior space for cooling said space. The cooling system comprises means for internal air circulation within the interior space, for conveying an external air circulation separated from the internal air circulation into
10 and out of the cooling system and for cooling the air in the internal circulation by means of the external air circulation.

According to the invention, the means for conveying the internal and/or external air circulation
20 comprise a body made from foamed material with a flow channel formed in it, through which at least part of the internal and/or external air circulation is passed.

The invention provides the advantage that the air channel system is simpler and considerably cheaper than earlier systems. Assembling the electronics cabinet becomes easier because the number of parts and holding fixtures is smaller than before. Moreover, the
25 noise generated by fans and air flow can be effectively damped because the vibrations are effectively damped by the foamed plastic material.

In an embodiment of the electronics cabinet, the body made of foamed material is a body of foamed
35 plastic.

In an embodiment of the electronics cabinet, the cooling system comprises an exterior wall, a first

partition wall placed at a distance from the exterior wall and substantially parallel with it; side walls which, together with the exterior wall and the first partition wall, form a hollow first interspace, into
5 which the body has been fitted; a first opening in the exterior wall, a second opening in the first partition wall; and an inlet flow channel in the body, serving to convey external air from the first opening into the second opening.

10 In an embodiment of the electronics cabinet, the cooling system comprises a second partition wall, which is located at a distance from the first partition wall and is substantially parallel with it and, together with the first partition wall and the side
15 walls, delimits a hollow second interspace and separates the cooling system from the interior cabinet space containing electronic parts to be cooled. The second partition wall is provided with a third opening. Further, an air-to-air heat exchanger is provided
20 in the second interspace. The heat exchanger divides the second interspace into four sub-spaces. The first and the second sub-spaces are for external air circulation and are located on opposite sides of the heat exchanger. The third and the fourth sub-spaces are for
25 internal air circulation and are correspondingly located on opposite sides of the heat exchanger. An external-air fan for creating an external air circulation is placed in a cut-out, opening or the like formed in the body in the area of the second sub-space
30 and constituting an exit channel for conveying the external air flow out of the cabinet. On the suction side, the external-air fan has been arranged to produce suction to draw the external air flow through the first opening, the inlet flow channel and the second
35 opening into the first sub-space and further through the heat exchanger into the second sub-space. From the second sub-space, the air flow is passed further via

the third opening in the first partition wall through the external-air fan, from where it is blown out of the cabinet through the outlet channel in the body.

In an embodiment of the electronics cabinet, the second partition wall comprises a fourth opening, which is located in the area of the third sub-space for passing internal air from the interior space into the third sub-space, and a fifth opening, which is located in the area of the fourth sub-space. The cooling system comprises an internal-air fan, which is disposed in the area of the fifth opening. The internal-air fan has been arranged to circulate the internal air from the interior space of the cabinet through the fourth opening into the third sub-space and further through the heat exchanger into the fourth sub-space and further via the fifth opening to the pressure side of the internal-air fan and back into the interior space.

In an embodiment of the electronics cabinet, the cooling system comprises air blow channels arranged to convey the cooled internal air blow from the internal-air fan into the interior space, between the electronic parts, such as electronic circuit cards.

In an embodiment of the electronics cabinet, the size of the body has been fitted to equal the size of the first interspace so as to fill substantially the entire first interspace.

In an embodiment of the electronics cabinet, the size of the body has been fitted to be smaller than the first interspace so as to leave some space for passing an air flow between the body and the walls delimiting the first interspace.

In an embodiment of the electronics cabinet, the electronics cabinet is a cabinet designed for use in outdoor locations, e.g. as an enclosure for a base transceiver station comprised in a wireless telecommunication system.

In the following, the invention will be described in detail by the aid of a few examples of its embodiments by referring to the attached drawings, wherein

5 Fig. 1 presents an axonometric oblique top view of an embodiment of the electronics cabinet of the invention, with the enclosure and the cooling system shown in separation from each other,

10 Fig. 2 presents the cooling system part of the embodiment in Fig. 1, with the second partition wall, which covers the second interspace containing the heat exchanger, removed,

15 Fig. 3 presents an embodiment of the air channel system of the electronics cabinet of the invention, formed from a foamed plastic body.

Fig. 4 presents section IV-IV of Fig. 2,

Fig. 5 presents section V-V of Fig. 4,

Fig. 6 presents section VI-VI of Fig. 4,

Fig. 7 presents section VII-VII of Fig. 2,

20 and

Fig. 8 presents partial section VIII-VIII of Fig. 7.

Fig. 1 shows an electronics cabinet, which in this example is an enclosure for a base transceiver station comprised in a wireless telecommunication system, designed for use in outdoor locations. Such an outdoor base station cabinet is exposed to weather, so it has to be of a tight structure. The electronics housed in the cabinet develops a fairly high temperature, e.g. as high as 90°C, in the interior space of the cabinet, which is cooled by means of an air cooling system 3. The figure shows an enclosure 1 with an interior space 2 where electronic parts, such as circuit cards and the like, can be mounted, and a cooling system 3, which can be installed as a compact unit in conjunction with the enclosure 1 so that it simultaneously forms a back wall.

25
30
35

The cooling system 3 comprises means for circulating air as a closed internal air circulation within the interior space. Moreover, the cooling system 3 comprises means for passing an open external air circulation separated from the internal air circulation into and out of the cooling system. The air circulated within the interior space is cooled by the external air circulation. The exchange of heat between the internal and the external air circulation systems is effected using an air-to-air heat exchanger 17 as shown in Fig. 2. The external air circulation has been described above by referring to Fig. 4 - 6, and the internal air circulation has been described by referring to Fig. 7 and 8.

Fig. 3 presents a foamed plastic body 4 formed from a single solid piece of foamed plastic material, containing flow channels 5, 6, 7, through which some of the external air circulation is conveyed. The foamed plastic body 4 is mounted inside the cooling system enclosure 3 as described below. The foamed plastic body 4 can be produced from plastic foam e.g. by the injection moulding method using one or two moulds.

As shown in Fig. 4 - 6, the cooling system part 3 comprises an exterior wall 8, a first partition wall 9, which is placed at a distance from the exterior wall and substantially parallel with it, and side walls 10, which, together with the exterior wall 8 and the first partition wall 9, form a hollow first interspace 11. The foamed plastic body 4 presented in Fig. 3 is mounted in this interspace 11. The size of the foamed plastic body 4 has been fitted to be smaller than the first interspace 11 so as to leave a space for passing the external air flow between the foamed plastic body 4 and the walls delimiting the first interspace 11.

As shown in Fig. 5, the exterior wall 8 has a first opening 12. The first partition wall 9 has a second opening 13. The foamed plastic body 4 contains an external air inlet channel 5 for conveying external air from the first opening 12 into the second opening 13.

The second partition wall 14 is located at a distance from the first partition wall 9 and is substantially parallel with it. Together with the first partition wall 9 and the side walls, the second partition wall 14 delimits a hollow second interspace 15. In addition, the second partition wall 14 separates the cooling system 3 from the interior cabinet space 2, which contains electronic parts to be cooled. The second partition wall 14 has a third opening 16.

An air-to-air heat exchanger 17 has been fitted in the second interspace 15. The heat exchanger 17 divides the second interspace into four sub-spaces 15¹, 15², 15³, 15⁴. The first sub-space 15¹ and the second sub-space 15² are for external air circulation and are located on opposite sides of the heat exchanger 17. The first sub-space 15¹ and the second sub-space 15² communicate with each other through the heat exchanger 17. The third sub-space 15³ and the fourth sub-space 15⁴ are for internal air circulation and are correspondingly located on opposite sides of the heat exchanger 17. The third sub-space 15³ and the fourth sub-space 15⁴ communicate with each other through the heat exchanger 17.

An external-air fan 18 creates an external air circulation. The external-air fan 18 is placed in a cut-out 6 formed in the foamed plastic body 4 in the area of the second sub-space 15². The cut-out constitutes an exit channel for conveying the external air flow out of the cabinet.

Referring to Fig. 4-5, the external air flow passes through the cooling system 3 as follows. The

external-air fan 18 sucks air from outside through the first opening 12, the inlet flow channel 5 and the second opening 13 into the first sub-space 15¹ and further through the heat exchanger 17 into the second sub-space 15², and from there further via the third opening 16 in the first partition wall 9 through the external-air fan 18 to the pressure side, from where the air is blown out of the cabinet through the outlet channels 6, 7 in the foamed plastic body 4. As shown in Fig. 4, the external air is passed out via two routes, by the top of the foamed plastic body 4 and by its sides. The left-hand flow route has been given a winding shape to ensure that the same flow resistance prevails in both outflow routes and to create a sufficient counterpressure for the fan 18.

As is best visible from Fig. 1 and 8, the second partition wall 14 has a fourth opening 19, which is located in the area of the third sub-space 15³ so that the internal air can flow from the interior space 2 into the third sub-space 15³. Located on the opposite side of the heat exchanger 17 in the area of the fourth sub-space 15⁴ is a fifth opening 20. An internal-air fan 21 is disposed in the area of the fifth opening 20.

As illustrated by Fig. 7 and 8, the internal air circulation functions as follows. The internal-air fan 21 circulates the internal air from the interior space 2 of the cabinet through the fourth opening 19 into the third sub-space 15³, from where the internal air flows through the heat exchanger 17. In the heat exchanger, the internal air delivers heat into the external air circulation and is cooled. The air then flows into the fourth sub-space 15⁴, from where it passes further via the fifth opening 20 through the internal-air fan 21, and the fan 21 blows it back into the interior space 2 of the cabinet via blow channels 22. The blow channels 22 convey the cooled internal

air flow from the internal-air fan 21 into the interior space 2, between the electronic parts, such as electronic circuit cards, placed in said space 2.

5 The invention is not restricted to the examples of its embodiments described above, but many variations are possible within the scope of the inventive idea defined by the claims.

CLAIMS

1. Electronics cabinet comprising an enclosure (1) with an interior space (2) where electronic parts, such as circuit cards and the like, can be mounted, and a cooling system (3) arranged as a substantially integral assembly with the enclosure in the immediate vicinity of its interior space for cooling the interior space, said cooling system (3) comprising means for internal air circulation within the interior space, for conveying an external air circulation separated from the internal air circulation into and out of the cooling system and for cooling the air in the internal circulation by means of the external air circulation, characterised in that the means for conveying the internal and/or external air circulation comprise a body (4) made from foamed material with a flow channel (5, 6, 7) formed in it, through which at least part of the internal and/or external air circulation is passed.

2. Cabinet as defined in claim 1, characterised in that said body (4) has been formed from foamed plastic.

3. Cabinet as defined in claim 1 or 2, characterised in that the cooling system (3) comprises an exterior wall (8); a first partition wall, (9) placed at a distance from the exterior wall and substantially parallel with it; side walls (10) which, together with the exterior wall and the first partition wall, form a hollow first interspace (11), into which said body (4) has been fitted; a first opening (12) in the exterior wall (8); a second opening (13) in the first partition wall (9); and an inlet flow channel (5) in said body (4), serving to convey external air from the first opening into the second opening.

4. Cabinet as defined in claim 3, characterised in that the cooling system (3) com-

prises a second partition wall (14), which is located at a distance from the first partition wall (9) and is substantially parallel with it and, together with the first partition wall and the side walls (10), delimits a hollow second interspace (15) and separates the cooling system from the interior cabinet space (2) containing electronic parts to be cooled, said first partition wall being provided with a third opening (16); an air-to-air heat exchanger (17) disposed in the second interspace (15) and dividing the second interspace into four sub-spaces (15¹, 15², 15³, 15⁴), of which the first sub-space (15¹) and the second sub-space (15²) are for external air circulation and are located on opposite sides of the heat exchanger while the third sub-space (15³) and the fourth sub-space (15⁴) are for internal air circulation and are correspondingly located on opposite sides of the heat exchanger; and an external-air fan (18) for creating an external air circulation, said fan being placed in a cut-out, opening or the like (6) formed in said body (4) in the area of the second sub-space (15²) and constituting an exit channel for conveying the external air flow out of the cabinet,

in which system the external-air fan has been arranged to produce suction creating an external air flow through the first opening, the inlet flow channel and the second opening into the first sub-space and further through the heat exchanger into the second sub-space, and from there further via the third opening in the first partition wall through the external-air fan to the pressure side to blow the external air flow out of the cabinet through the outlet channel in said body.

5. Cabinet as defined in claim 4, characterised in that the second partition wall (14) comprises a fourth opening (19), which is located in the area of the third sub-space (15³) for passing in-

ternal air from the interior space (2) into the third sub-space, and a fifth opening (20), which is located in the area of the fourth sub-space (15⁴); and that the cooling system comprises a internal-air fan (21) disposed in the area of the fifth opening (20)

the internal-air fan being arranged to circulate the internal air from the interior space of the cabinet through the fourth opening into the third sub-space and further through the heat exchanger into the fourth sub-space and from there further via the fifth opening to the pressure side of the internal-air fan and back into the interior space.

6. Cabinet as defined in any one of claims 1 - 5, characterised in that the cooling system comprises an air blow channel (22) arranged to convey the cooled internal air blow from the internal-air fan (21) into the interior space (2), between the electronic parts, such as electronic circuit cards.

7. Cabinet as defined in any one of claims 1 - 6, characterised in that the size of said body (4) has been fitted to equal the size of the first interspace (11) so as to fill substantially the entire first interspace.

8. Cabinet as defined in any one of claims 1 - 5, characterised in that the size of said body (4) has been fitted to be smaller than the first interspace (11) so as to leave some space for passing an air flow between the body and the walls delimiting the first interspace.

9. Cabinet as defined in any one of claims 1 - 8, characterised in that the electronics cabinet is a cabinet designed for use in outdoor locations, e.g. as an enclosure for a base transceiver station comprised in a wireless telecommunication system.

10. Air channel system for an electronics cabinet, comprising an air channel (5, 6, 7),

characterised in that the air channel (5, 6, 7) has been formed in a body (4) made of foamed material.

11. Air channel system as defined in claim 5 10, characterised in that said body (4) is made of foamed plastic.

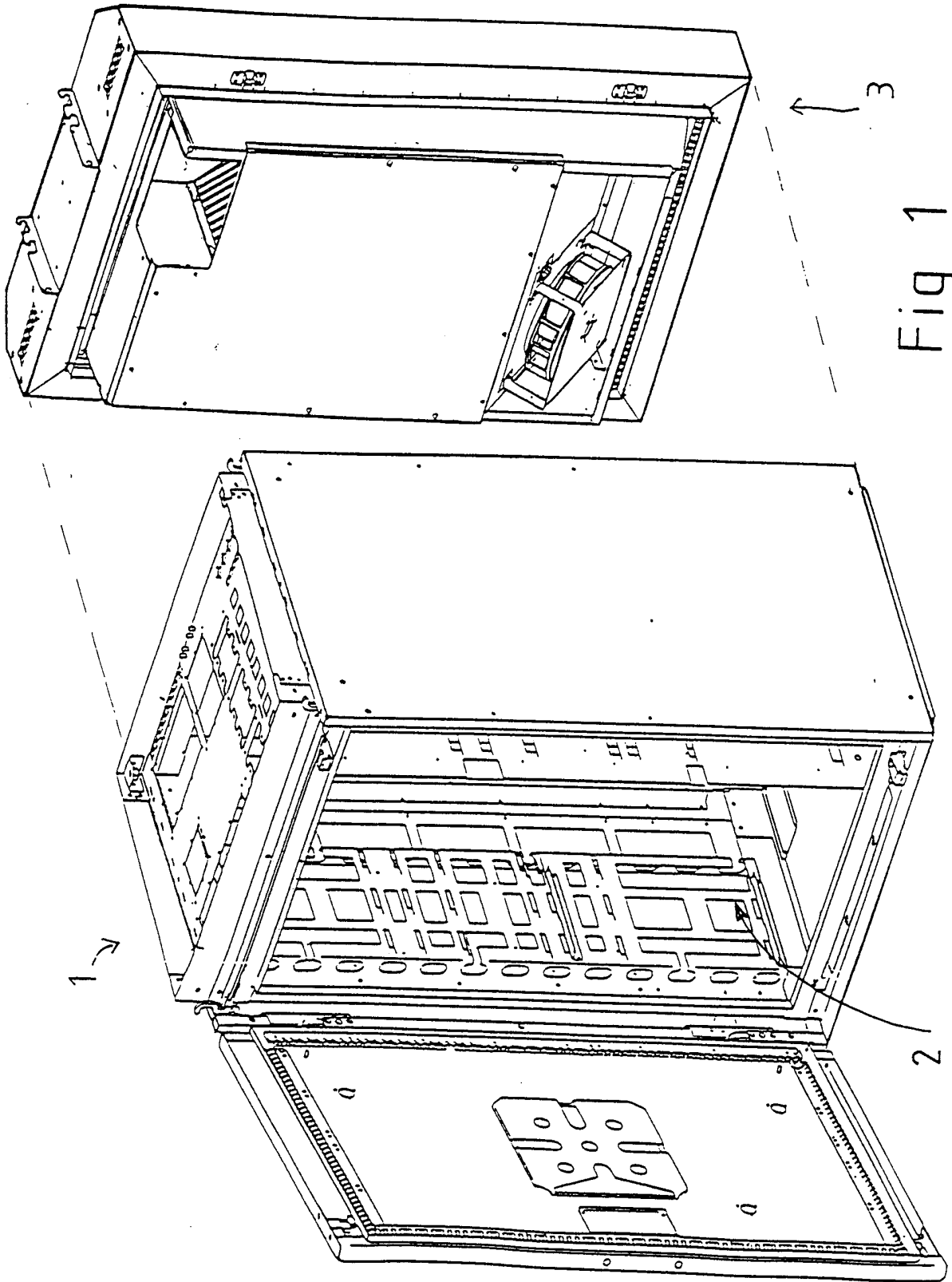

Fig 1

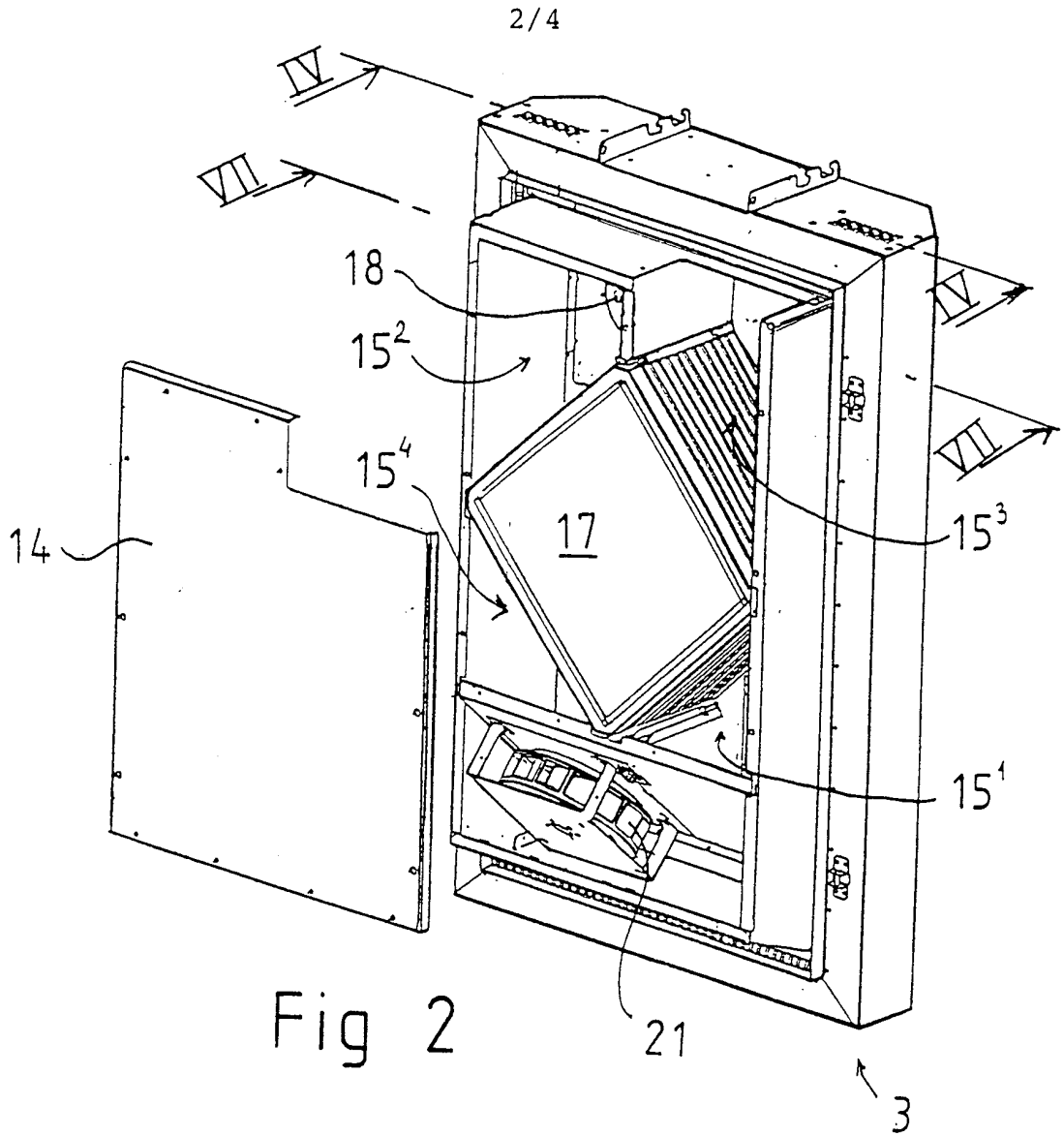

Fig 2

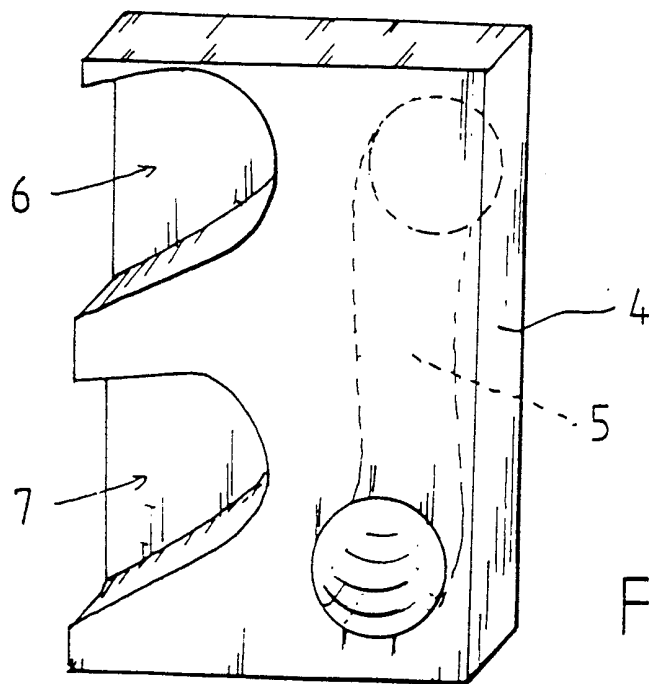

Fig 3

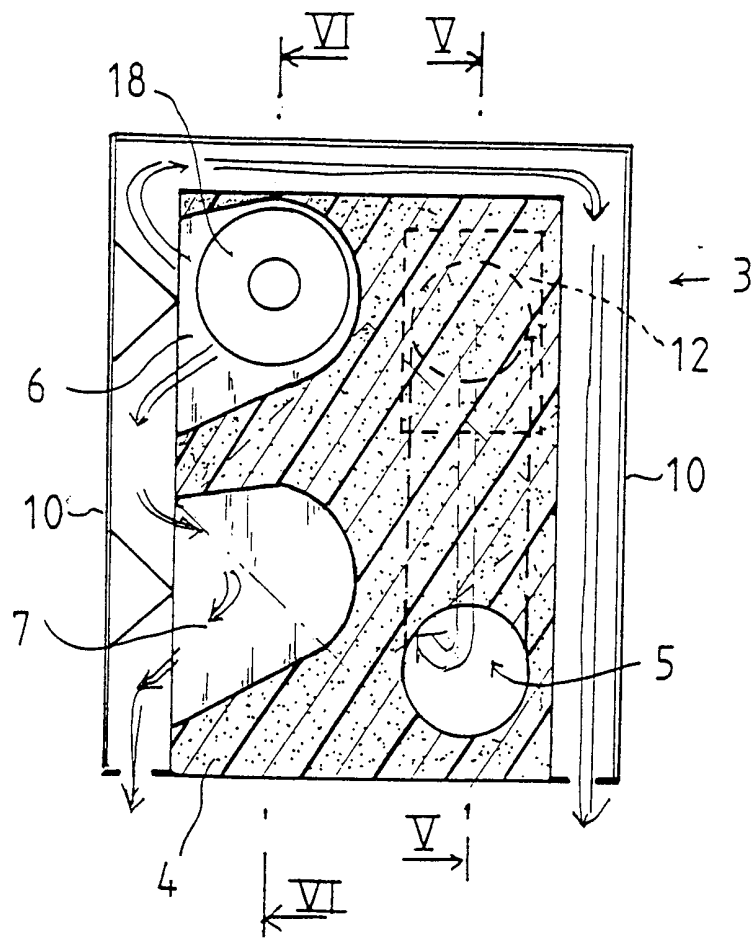

Fig 4

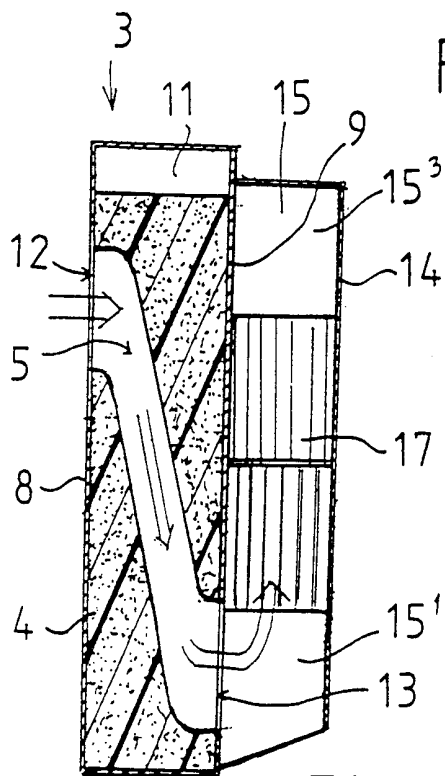

Fig 5

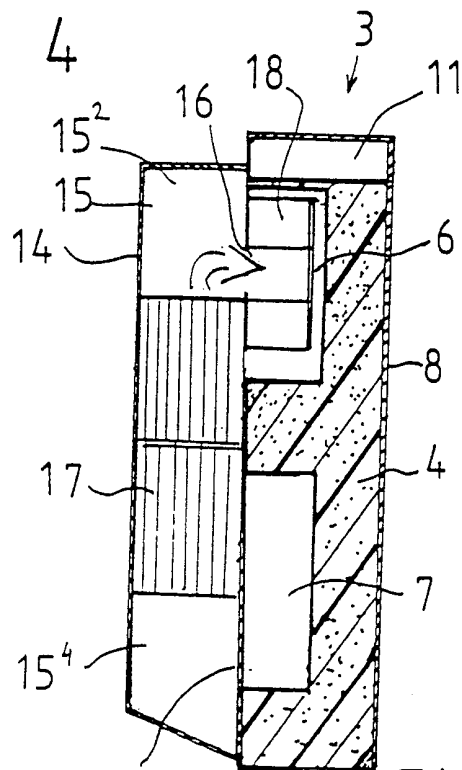
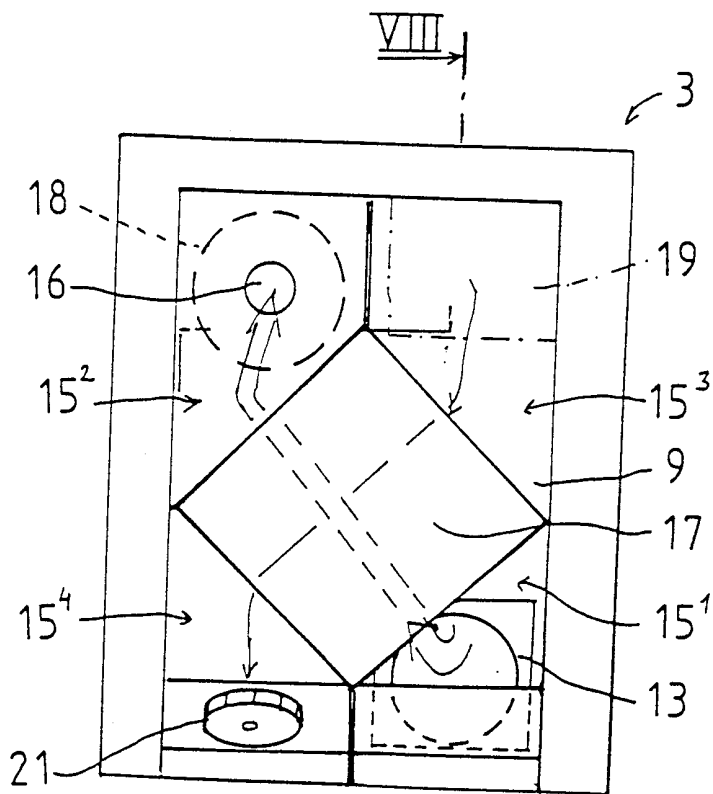

Fig 6



VIII → Fig 7

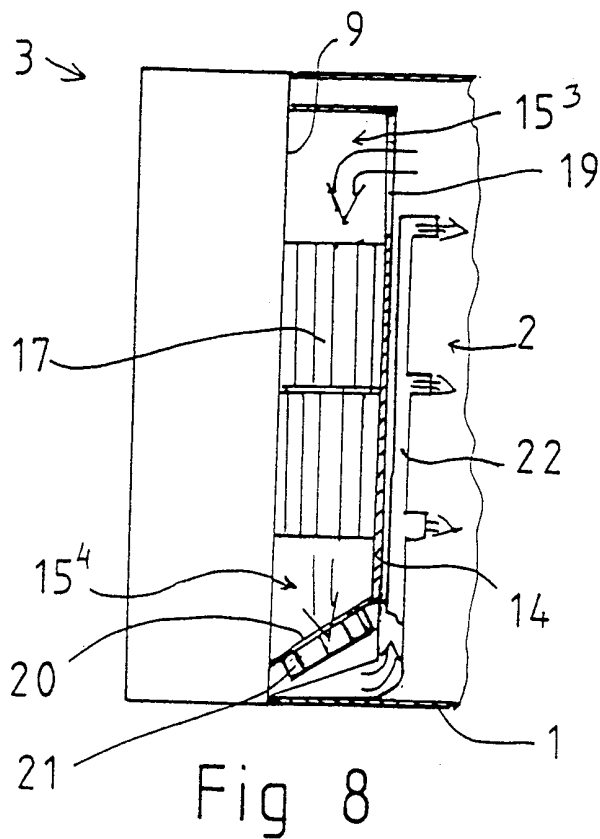

Fig 8

INTERNATIONAL SEARCH REPORT

International application No.
PCT/FI 98/00742

A. CLASSIFICATION OF SUBJECT MATTER		
IPC6: H05K 7/20 According to International Patent Classification (IPC) or to both national classification and IPC		
B. FIELDS SEARCHED		
Minimum documentation searched (classification system followed by classification symbols)		
IPC6: H05K, G10K		
Documentation searched other than minimum documentation to the extent that such documents are included in the fields searched		
SE,DK,FI,NO classes as above		
Electronic data base consulted during the international search (name of data base and, where practicable, search terms used)		
EPODOC, WPI, PAJ		
C. DOCUMENTS CONSIDERED TO BE RELEVANT		
Category*	Citation of document, with indication, where appropriate, of the relevant passages	Relevant to claim No.
X	US 5644472 A (DEAN A KLEIN), 1 July 1997 (01.07.97), column 2, line 37 - line 47; column 2, line 54 - line 57, abstract	10-11
Y	--	1-9
Y	WO 9724911 A1 (NOKIA TELECOMMUNICATIONS OY), 10 July 1997 (10.07.97), page 3, line 16 - page 4, line 2, abstract	1-9
Y	GB 2277767 A (NOKIA TELECOMMUNICATIONS OY), 9 November 1994 (09.11.94), page 5, line 17 - line 28, abstract	1-9
	--	
<input checked="" type="checkbox"/> Further documents are listed in the continuation of Box C. <input checked="" type="checkbox"/> See patent family annex.		
* Special categories of cited documents: "A" document defining the general state of the art which is not considered to be of particular relevance "E" earlier document but published on or after the international filing date "L" document which may throw doubts on priority claim(s) or which is cited to establish the publication date of another citation or other special reason (as specified) "O" document referring to an oral disclosure, use, exhibition or other means "P" document published prior to the international filing date but later than the priority date claimed "I" later document published after the international filing date or priority date and not in conflict with the application but cited to understand the principle or theory underlying the invention "X" document of particular relevance: the claimed invention cannot be considered novel or cannot be considered to involve an inventive step when the document is taken alone "Y" document of particular relevance: the claimed invention cannot be considered to involve an inventive step when the document is combined with one or more other such documents, such combination being obvious to a person skilled in the art "&" document member of the same patent family		
Date of the actual completion of the international search		Date of mailing of the international search report
15 March 1999		17-03-1999
Name and mailing address of the ISA/ Swedish Patent Office Box 5055, S-102 42 STOCKHOLM Facsimile No. +46 8 666 02 86		Authorized officer Karin Säfsten Telephone No. +46 8 782 25 00

INTERNATIONAL SEARCH REPORT

International application No.

PCT/FI 98/00742

C (Continuation). DOCUMENTS CONSIDERED TO BE RELEVANT		
Category*	Citation of document, with indication, where appropriate, of the relevant passages	Relevant to claim No.
Y	US 5467250 A (PAUL A. HOWARD ET AL), 14 November 1995 (14.11.95), column 2, line 36 - column 3, line 52; column 8, line 2 - line 32, abstract --	1-9
A	DE 3408139 A1 (SCHROFF GMBH), 12 Sept 1985 (12.09.85), abstract --	10-11
A	FR 2078558 (SIEMENS AKTIENGESELLSCHAFT), 5 November 1971 (05.11.71), page 5, line 18 - line 29 --	1-9
A	DK 157649 B (BANG & OLUFSEN A/S), 29 January 1990 (29.01.90), abstract --	1-9
A	EP 0515329 A2 (BETHLEN DE BETHLEN), 25 November 1992 (25.11.92), column 4, line 21 - line 40, figure 5, abstract --	1-9
A	US 4386651 A (HEINRICH REINHARD), 7 June 1983 (07.06.83), abstract -- -----	1-9

INTERNATIONAL SEARCH REPORT

Information on patent family members

02/03/99

International application No.

PCT/FI 98/00742

Patent document cited in search report	Publication date	Patent family member(s)	Publication date
US 5644472 A	01/07/97	NONE	

WO 9724911 A1	10/07/97	AU 1196997 A EP 0880875 A FI 956361 A NO 982994 A	28/07/97 02/12/98 30/06/97 26/06/98

GB 2277767 A	09/11/94	NONE	

US 5467250 A	14/11/95	NONE	

DE 3408139 A1	12/09/85	NONE	

FR 2078558	05/11/71	AT 303814 A,B BR 7100691 D CH 525598 A DE 2006759 A ZA 7100670 A	15/11/72 00/00/00 15/07/72 26/08/71 27/10/71

DK 157649 B	29/01/90	DK 360083 A	25/02/84

EP 0515329 A2	25/11/92	DE 69205492 D IT 1249740 B IT RM910349 D	00/00/00 11/03/95 00/00/00

US 4386651 A	07/06/83	AT 16229 T AU 7788981 A DE 3045326 A,C EP 0057244 A,B SE 0057244 T3 JP 1622734 C JP 2035238 B JP 57120088 A	15/11/85 10/06/82 03/06/82 11/08/82 25/10/91 09/08/90 26/07/82
