

(No Model.)

4 Sheets—Sheet 1.

C. H. WOOD.
COIN PACKAGE DELIVERY DEVICE.

No. 522,816.

Patented July 10, 1894.

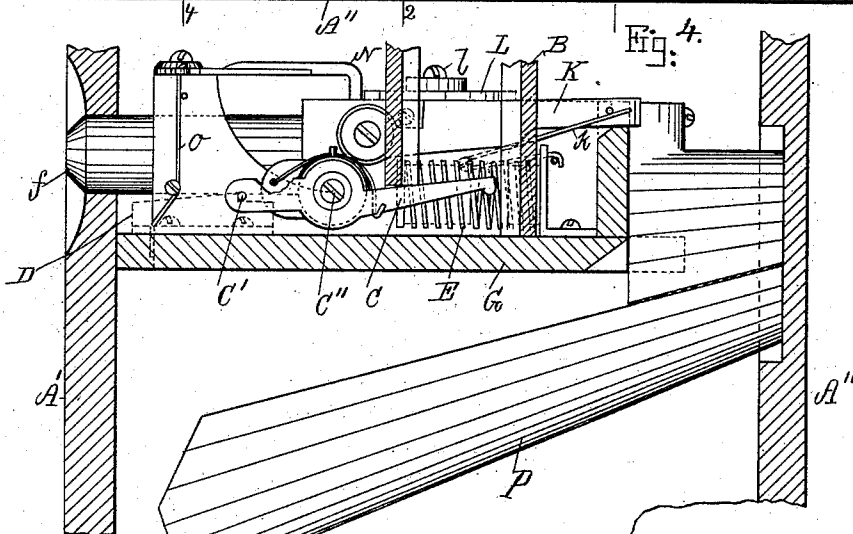
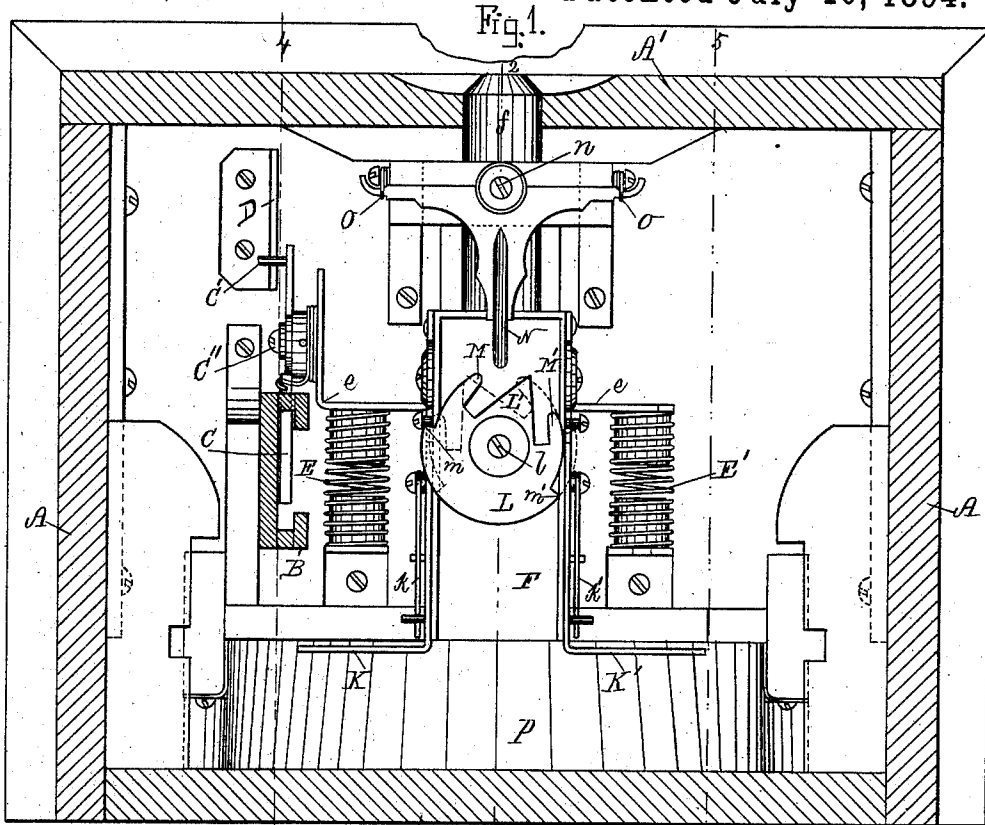

Witnesses.

Laurie N. Bolter.
Katie M. Hanson.

Inventor

Clarence H. Wood
by *Alvan Audren*
his atty.

C. H. WOOD.
COIN PACKAGE DELIVERY DEVICE.

No. 522,816.

Patented July 10, 1894.

Fig. 2.

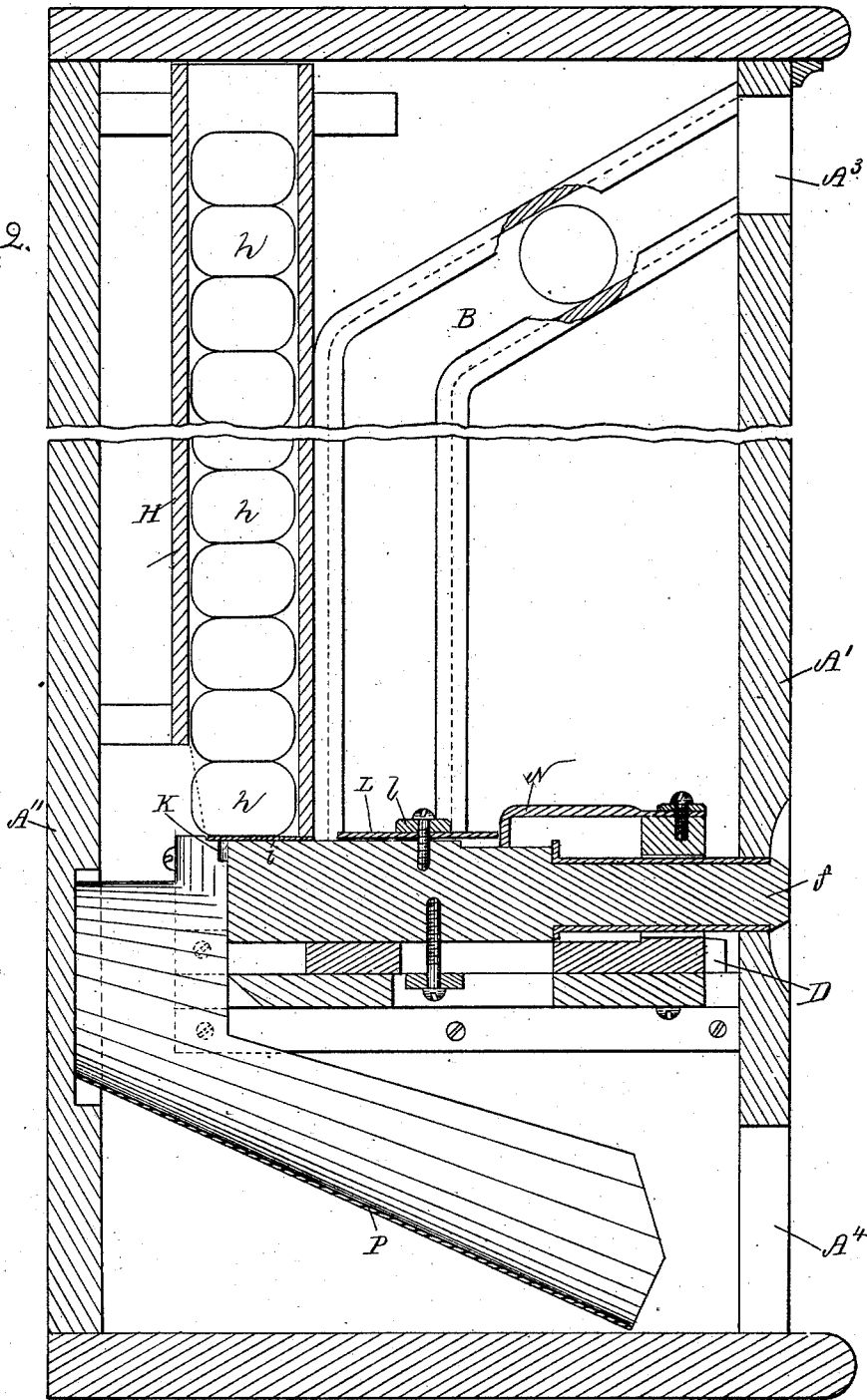

Witnesses.

Laird, N. Moller,
Katie M. Hanson.

Inventor.

Clarence H. Wood.
by Alvan Andrew his atty.

C. H. WOOD.
COIN PACKAGE DELIVERY DEVICE.

No. 522,816.

Patented July 10, 1894.

Fig. 3.

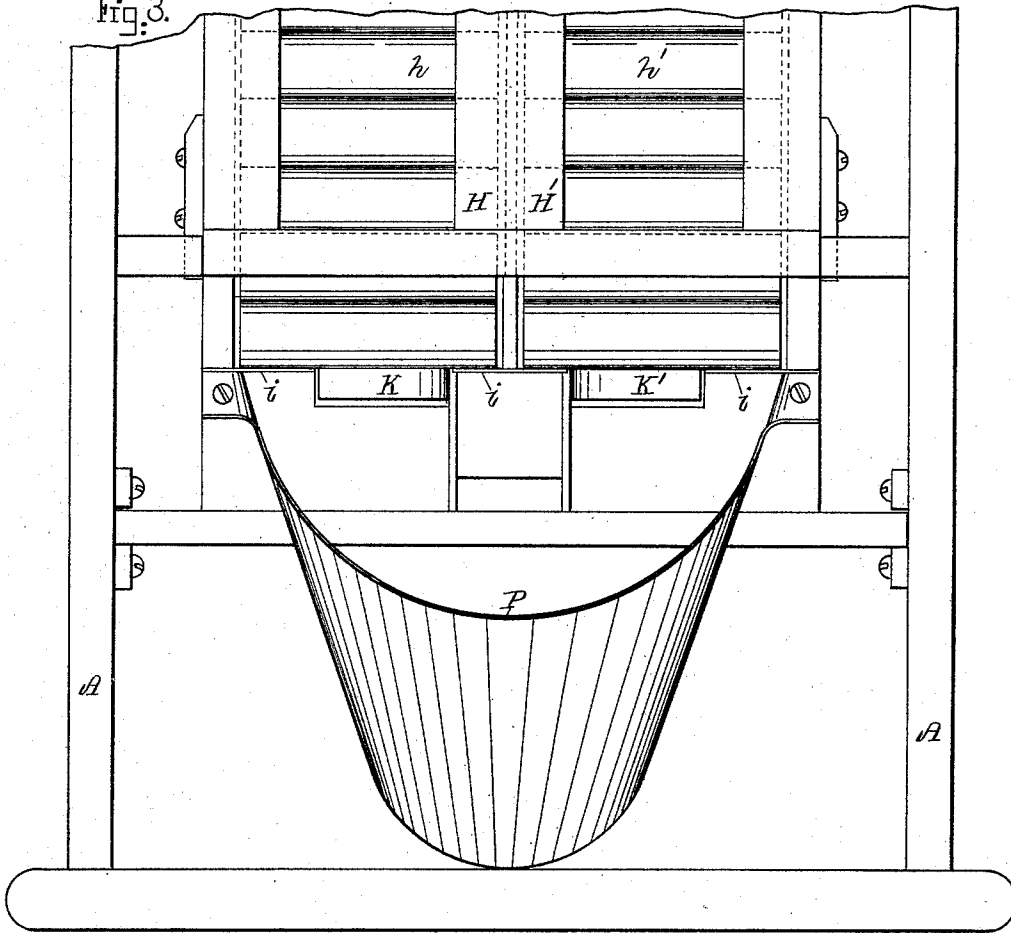
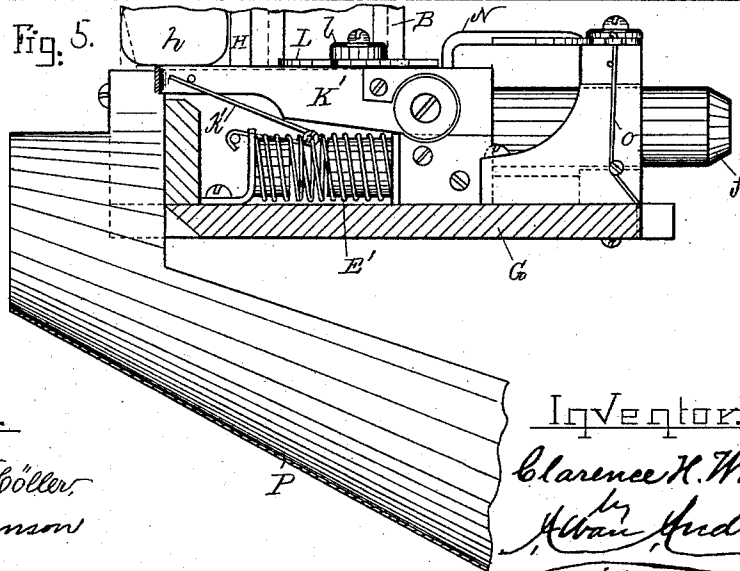

Fig. 5.



Witnesses.

Lewis N. Böller,
Katie W. Hanson

Inventor.

Clarence H. Wood
by
Alvan Andrieu
his atty.

(No Model.)

4 Sheets—Sheet 4.

C. H. WOOD.
COIN PACKAGE DELIVERY DEVICE.

No. 522,816.

Patented July 10, 1894.

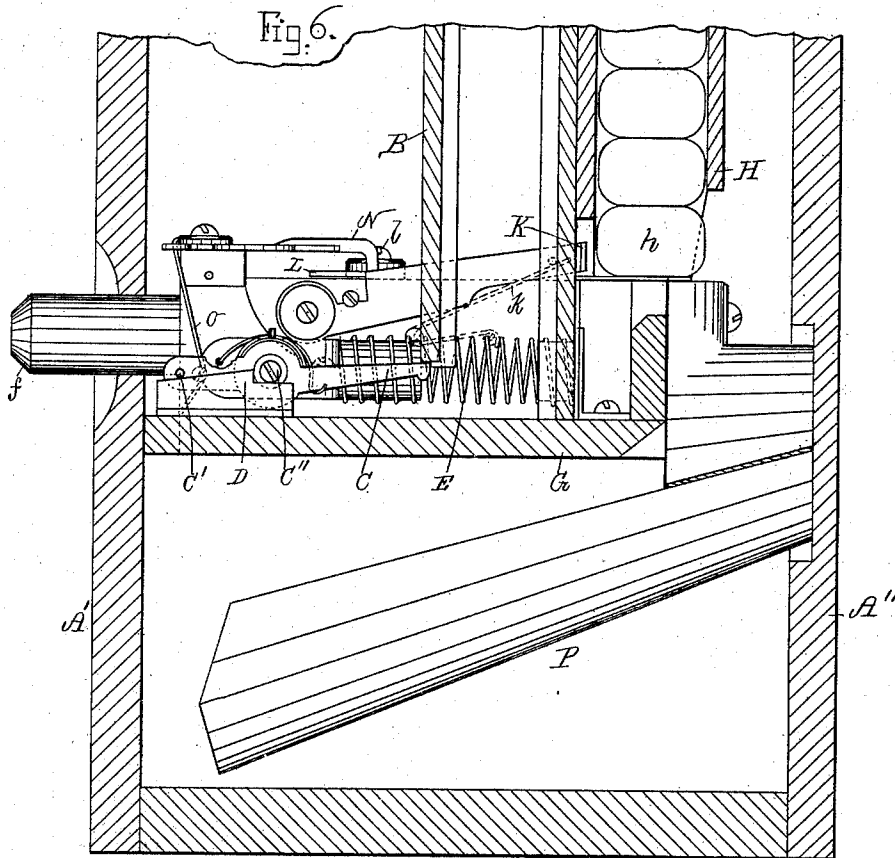

Witnesses

Laird N. Miller
Arthur M. Hanson

Inventor

Charles H. Wood
by *Alban Audien*
his atty.

UNITED STATES PATENT OFFICE.

CLARENCE H. WOOD, OF BOSTON, ASSIGNOR OF ONE-HALF TO SOLOMON
WOODBERRY, OF REVERE, MASSACHUSETTS.

COIN PACKAGE-DELIVERY DEVICE.

SPECIFICATION forming part of Letters Patent No. 522,816, dated July 10, 1894.

Application filed November 2, 1893. Serial No. 489,790. (No model.)

To all whom it may concern:

Be it known that I, CLARENCE H. WOOD, a citizen of the United States, and a resident of Boston, in the county of Suffolk and State of Massachusetts, have invented new and useful Improvements in Coin Package-Delivery Devices, of which the following, taken in connection with the accompanying drawings, is a specification.

This invention relates to improvements in coin package delivery devices and it consists in combination with an inclosing case and ways therein for the packages and a coin conveyer having a press button holding and locking device adapted to be released by the weight of the coin and a press button normally held in its pushed back position and automatically forced outward when released and a picking device for pushing out a package from the ways within the box and a delivery chute or opening as will hereinafter be more fully shown and described, reference being had to the accompanying drawings, wherein—

Figure 1, represents a top plan view of the invention showing the case in section. Fig. 2, represents a vertical section on the line 2—2 shown in Fig. 1. Fig. 3, represents a rear view of the lower portion of the apparatus. Fig. 4, represents a vertical section on the line 4—4 in Fig. 1, showing the press button pushed inward and held locked in its normal position. Fig. 5, represents a vertical section on the line 5—5 in Fig. 1, showing the press button in the same position as in Figs. 1 and 4; and Fig. 6, represents a section similar to Fig. 4 and showing the press button released and forced outward and one of the packages ready for discharge by the inward movement of the press button.

Similar letters refer to similar parts wherever they occur on the different parts of the drawings.

A, represents a suitable inclosing case of which A' is the front, and A'' the removable back portion or cover. Through the front A' is made a coin slot A^s which connects with a coin conveyer or chute B, the lower end of which is normally held closed by a small pivoted spring pressed lever C which is provided with a pin or side projection C' in its forward

end adapted to rest against a stationary stop projection D when in its normal position as shown in Figs. 1 and 4.

The coin actuated lever C is pivoted at C'' to a bracket e, secured to one side of the longitudinally movable block F, to the forward end of which is attached the press button f, which passes loosely through a perforation in the front A' of the case A as shown. To the opposite side of said block F is attached a bracket e' (similar to the bracket e) and between said brackets and stationary projections on the base plate G are arranged the respective springs E and E' which when the coin lever C is released causes the block F and its connections to move from the position shown in Figs. 1, 2, 4 and 5 to the position shown in Fig. 6.

Back of the coin chute are arranged the preferably detachable package holders H and H' within which are contained the respective piles of packages h and h' as shown in Figs. 2, 3 and 6; such packages being arranged loosely one on the top of another in said package holders, and if the packages are very light a suitable weight may be placed on top of the piles as is common in devices of this kind. At the bottom of the package holders are inwardly projecting ledges i, i, i, on which the piles of packages are normally supported as shown in Figs. 2, 3 and 6.

To the sides of the longitudinally movable block F are pivoted the respective package ejectors K and K' which when released are raised at their rear free ends by the influence of suitable springs k and k' as shown in Figs. 1, 4, 5 and 6.

To the top of the movable block F is frictionally pivoted at l, a reversing disk L having a preferably triangularly shaped central tooth or projection L' at the side of which are grooves or notches M, M', and at the rear end of the latter the said disk has the respective radial ears or projections m, m', as fully shown in Fig. 1 said wings serving the purpose of intermittently releasing one of the package ejectors K K' and allow it to spring upward during the forward motion of the press button f, and its block F so as to cause such raised ejector to force out the lowest package

from the corresponding pile during the pressing inward of the button *f*, as will hereinafter be more fully shown and described.

At *n*, above the press button *f*, is pivoted the finger lever or ejector reversing arm N which is adapted to yield slightly to the right and left and is normally held yieldingly in its central position as shown in Fig. 1 by the influence of suitable springs O, O, as shown in Figs. 1, 4, 5 and 6.

Back of the package holders is arranged an inclined package chute P into which the packages when ejected are dropped and made to slide out through an opening A⁴ in the lower portion of the front wall A' as shown in the drawings.

The operation of this coin package delivery device is as follows: After the package holders have been filled, the case is closed as usual in devices of this kind. If now a coin of the desired value is dropped through the slot A³ into the chute B, as it strikes the lever C, the pin C' thereon is caused to be released from the stop projection D, by which the block F and parts connected thereto, as well as the press button *f*, are released and moved by the influence of the springs E E' from the position shown in Figs. 1, 2, 4 and 5 to that shown in Fig. 6. When the lever C, reaches the position shown in Fig. 6 the coin is free to drop into any suitable lock box or receptacle to be collected from time to time as may be desired. During the forward motion of the block F, the spring pressed arm N is caused to enter the groove M on the disk L by which the latter is automatically turned from the position shown in full lines in Fig. 1 to that shown by dotted lines in said Fig. 1 and in so doing the ejector lever K is liberated from the ear *m*, and forced upward by the influence of its spring to the position shown in Fig. 6 as soon as the block F reaches the limit of its forward motion. In this position of the disk L its ear *m'* acts as a stop against the ejector lever K' causing it to be held below the package pile as fully shown in Fig. 5; by now pushing the press button *f* inward to its original position the now raised ejector lever K will cause the lowest package *h* in the holder H to be forced backward into the chute P from which it may be readily taken by the purchaser. When the block F assumes its normal position shown in Figs. 1 and 2 the rear end of the lever K is depressed by the packages resting thereon. If now another coin is dropped into the slot A³ the same operation as above stated takes place, but this time the arm N enters the slot M' and causes the disk L to turn from the dotted line position to the full line position shown in Fig. 1 by which the lever K is held down and the lever K' liberated from said disk L and by pushing in the press button *f* the ejector K' causes a package *h'* from the pile in the holder H' to be ejected and dropped into the chute P and

so on alternately picking from one or the other of the packages in the holders H H', and so on. As the press button *f* is pressed inward to its normal position shown in Fig. 5 the coin lever C is held from moving forward by its pin C' being brought to a stop against the notch D as shown in Fig. 4 and by this means the block F and its connections are held against the influence of the springs E E' in the position shown in Figs. 1, 2, 4 and 5 until released by the dropping of a coin into the apparatus.

Having thus fully described the nature, construction, and operation of my invention, I wish to secure by Letters Patent and claim—

1. In a coin package delivery device, a coin chute and a pivoted locking lever arranged at the bottom of the same, combined with a spring pressed sliding block provided with a push button, a pair of spring pressed ejector levers pivoted on said block, a pair of package holders, a reversing disk pivoted on the sliding block, and a yielding pivoted reversing arm substantially as and for the purpose set forth.

2. In a coin package delivery device, a coin chute having a pivoted locking lever at its lower end, a spring pressed block having a press button, combined with a pair of package holders, a pair of pivoted spring pressed ejector levers, a notched reversing disk pivoted to said block and having wings or projections for alternately holding one of the ejector levers downward, and a pivoted yielding reversing arm adapted to engage the notched reversing disk so as to cause the packages to be ejected alternately from the respective package holders substantially as and for the purpose set forth.

3. In a coin package delivery device, a spring pressed sliding block having a push button connected to it, and having a notched reversing disk, and a pair of spring pressed ejector levers pivoted to it, combined with a pivoted and yielding reversing arm, and a pair of package holders, substantially as and for the purpose set forth.

4. In a coin package delivery device, a spring pressed push button normally held locked in a rear position and adapted to be released by a coin, and having in connection with it a pair of spring pressed ejector levers adapted when pressed inward to alternately eject a package from a pair of package containing holders substantially as and for the purpose set forth.

In testimony whereof I have signed my name to this specification, in the presence of two subscribing witnesses, on this 7th day of October, A. D. 1893.

CLARENCE H. WOOD.

Witnesses:

ALBAN ANDRÉN,
KITTIE M. HANSON.