

(No Model.)

6 Sheets—Sheet 1.

R. PEDERSON.
CORN HARVESTER.

No. 522,386.

Patented July 3, 1894.

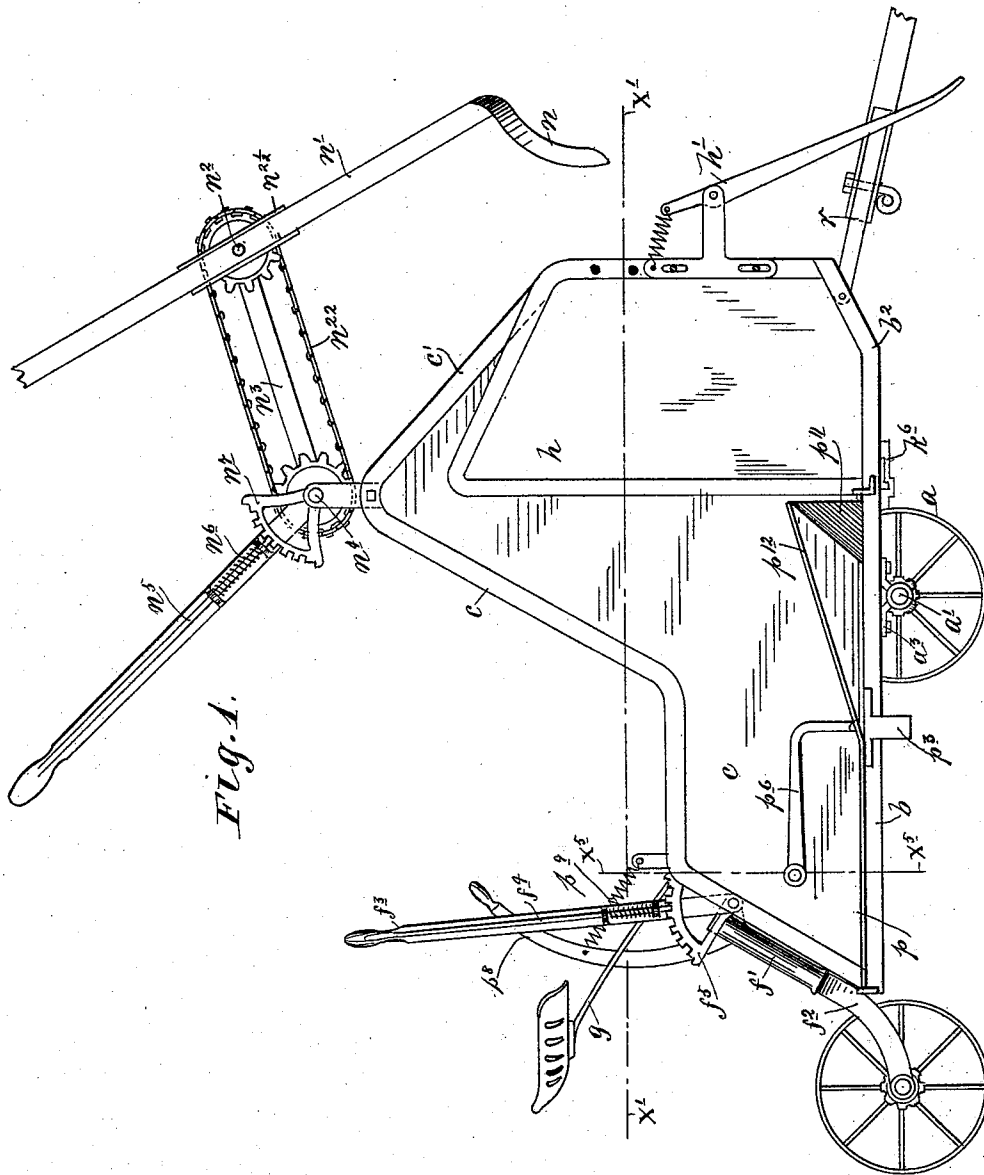

Witnesses.
A. H. Opsahl.
Frank Merchant.

Inventor.
Rasmus Pederson
By his Attorney
Jas. F. Williamson

(No Model.)

6 Sheets—Sheet 3.

R. PEDERSON.
CORN HARVESTER.

No. 522,386.

Patented July 3, 1894.

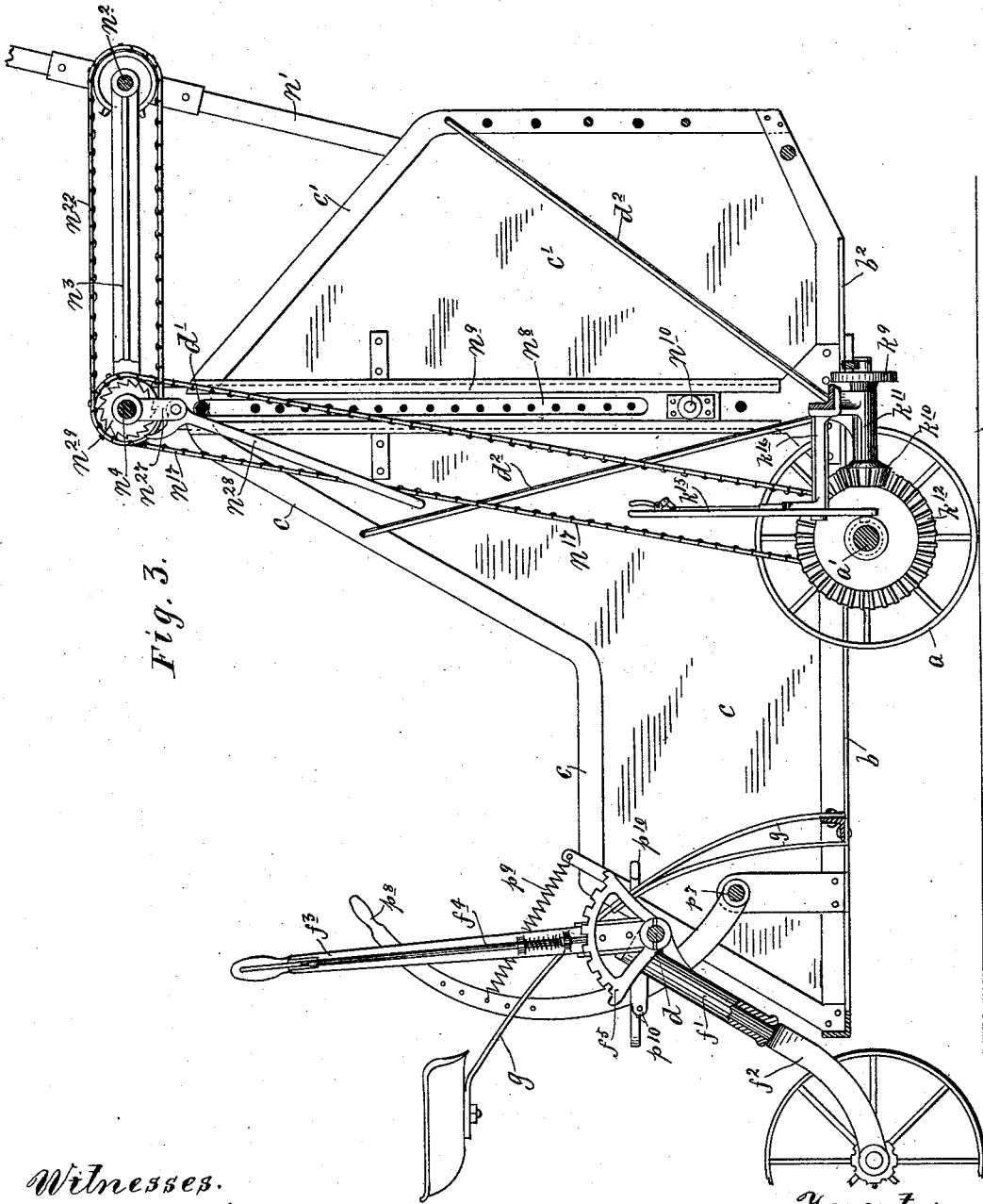

Fig. 3.

Witnesses.
A. H. Opsahl.
Frank D. Merchant

Inventor.
Rasmus Pederson
By his Attorney.
Jas. P. Williamson

R. PEDERSON.
CORN HARVESTER.

No. 522,386.

Patented July 3, 1894.

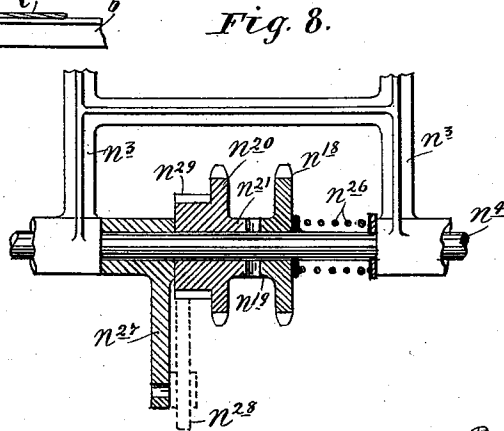
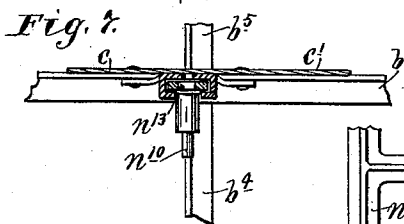
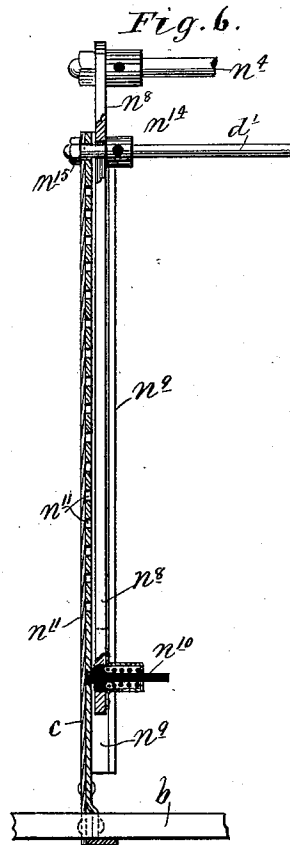
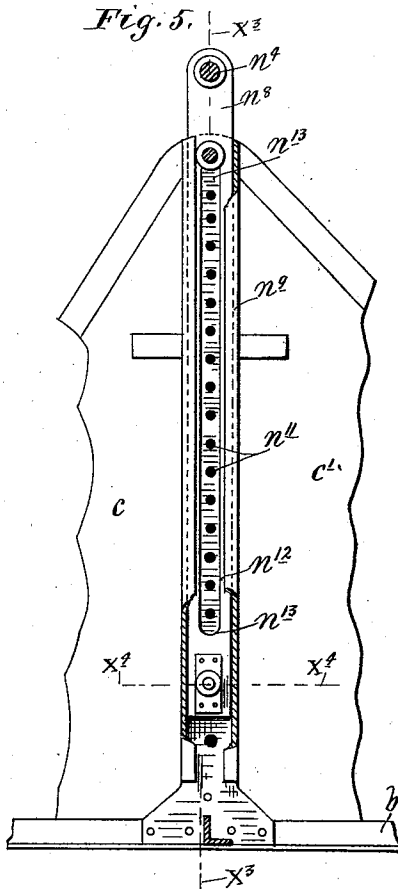

Witnesses.
 A. H. Opsahl
 Frank D. Merchant

Inventor.
 Rasmus Pederson
 By his Attorney,
 Jas. F. Williamson

R. PEDERSON.
CORN HARVESTER.

No. 522,386.

Patented July 3, 1894.

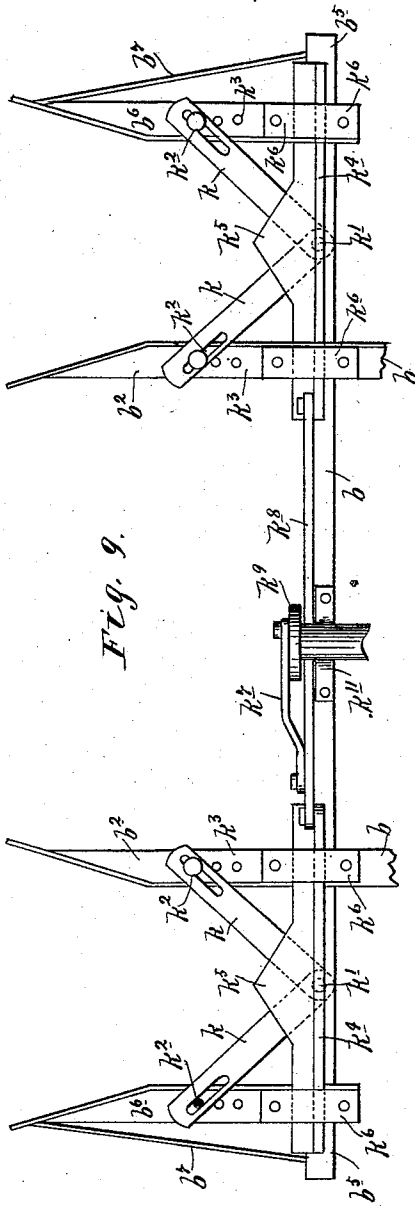

Fig. 9.

Fig. 10.

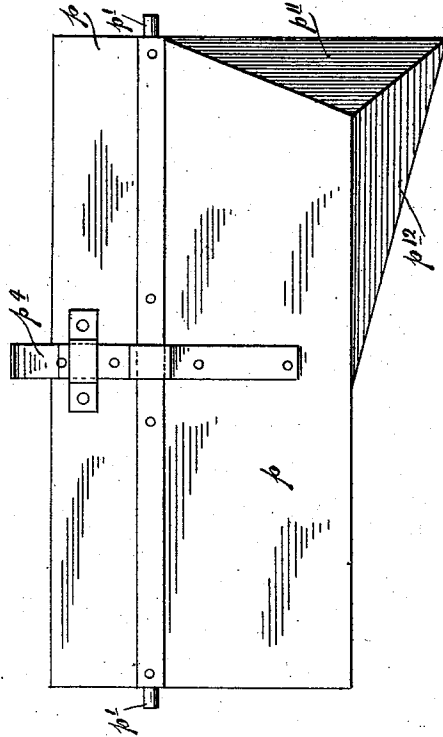
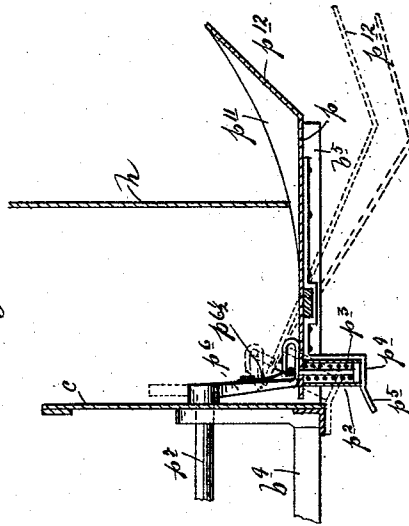

Fig. 11.



Witnesses.
 a. H. Opsahl.
 Frank L. Merchant,

Inventor.
 Rasmus Pederson
 By his attorney.
 Jas. F. Williamson

UNITED STATES PATENT OFFICE.

RASMUS PEDERSON, OF DRAMMAN, MINNESOTA.

CORN-HARVESTER.

SPECIFICATION forming part of Letters Patent No. 522,386, dated July 3, 1894.

Application filed January 2, 1894. Serial No. 495,336. (No model.)

To all whom it may concern:

Be it known that I, RASMUS PEDERSON, a citizen of the United States, residing at Dramman township, in the county of Lincoln and State of Minnesota, have invented certain new and useful Improvements in Corn-Harvesters; and I do hereby declare the following to be a full, clear, and exact description of the invention, such as will enable others skilled in the art to which it appertains to make and use the same.

My invention relates to corn-harvesters.

In certain of its features, the machine herein shown and described, is similar to the machines described in my former United States patent, No. 494,023, of date March 21, 1893, and my pending application, Serial No. 478,775, filed of date June 26, 1893. Several important features of improvement have, however, been added, with a view of rendering the machine more efficient.

My improved machine will be hereinafter fully described; and the novel parts and combinations of parts, therein contained, will be defined in the claims.

The machine is illustrated in the accompanying drawings, wherein, like letters referring to like parts throughout—

Figure 1 is a right side elevation, with some parts broken away. Fig. 2 is a view, partly in plan and partly in horizontal section, approximately on the line $X' X'$ of Fig. 1. Fig. 3 is a longitudinal vertical section through the entire machine, approximately on the line $X^2 X^2$ of Fig. 2, with some parts removed and others broken away. Fig. 4 is a front elevation of the machine, with some parts removed. Fig. 5 is a detail in inside vertical elevation, with some parts broken away, showing the two-part or sectional telescoping standards, for the reel carrier shaft. Fig. 6 is a vertical section, on the line $X^3 X^3$ of Fig. 5. Fig. 7 is a cross section, on the line $X^4 X^4$ of Fig. 5. Fig. 8 is a detail, partly in plan and partly in section, showing a part of the reel carrier, and the clutch members in the reel drive, &c. Fig. 9 is a bottom plan of the gathering crotches, crotch-knives, reciprocating cutters, &c., detached. Fig. 10 is a bottom plan of one of the dumping tables or bundle-carriers,

detached. Fig. 11 is a section of one of the bundle-carriers and a part of the main frame, on the line $X^5 X^5$ of Fig. 1, looking toward the front.

The ground-wheels a , are loose on the main axle a' and have pawl and ratchet connection therewith, (not shown.) The axle a' is mounted in bearings a^3 , fixed to an angle-iron frame base. This frame base is composed of side members $b b' b^2$, and cross-members b^3 and $b^4 b^5 b^6$. These side and cross members are all rigidly bolted together and constitute a strong base for the other parts of the main frame. Of the side members, the parts b' are bent outward, at the rear ends of the body portions b , to form rear end supports, for the dumping table; and the parts b^2 project forward of the front end cross member, to form supports for the inside gathering plates, thills, &c. Of the cross members, the bar is rigidly bolted to the body portions b of the side members; and the front end member has the parts b^5 extended outward beyond the side members, and the part b^6 bent upon the parts b^5 , and extended forward parallel with the parts b^2 of the side members, which parts $b^5 b^6$, serve to support a number of the other parts of the machine, which will presently be noted. The parts b^6 are braced by rods b^7 .

To the side members of the base are rigidly secured the vertical side plates c , and the inside gathering plates c' ; which plates are formed integral with each other and of the shape shown in Figs. 1 and 3. The frame is further braced crosswise, by the lifting or frame tilting shaft d , fixed to the side plates c , near their rear ends; and by a clamping rod d' , which connects the combined side plates and gathering plates at the top junctions of the same and co-operates with some other parts, for holding the reel carrier shaft in any desired vertical adjustment. Stay rods d^2 also brace the plates $c c'$ from the frame base.

On the shaft d , is loosely sleeved a caster-wheel carrier or bracket f , having a downwardly extended sleeve portion f' , in which is pivoted the caster-wheel f^2 . To the bracket f , is fixed the hand-lever f^3 with spring-pawl f^4 , engageable with the lock segment f^5 , fixed

100

to the shaft d , for throwing the caster-wheel forward or backward with respect to the ground-wheels a , and thereby raising or lowering the front end of the main frame by tilting the frame on the axle a' . The driver can reach the lever f^3 from the spring-seat g , supported from the main frame.

To the portions b^2 , b^5 , b^6 of the frame-base, are fixed the outside gathering plates h , for co-operation with the inside gathering plates c' . To the gathering plates c' and h , are adjustably secured a pair of yielding held arighting arms h' , which work at an inward and downward dip, and serve to lift up and direct to the gathering plates the fallen or tangled stalks of corn.

To the portions b^2 , b^5 , b^6 of the frame-base, are secured the crotch-knives k . The connection of the knives k to the parts b^5 , is by pivot-pins k' ; and the connection of the same to the parts b^2 , b^6 is by slot and pin engagement, as shown at k^2 , the pins of which may engage with any one of the series of holes k^3 , formed in the said parts b^2 , b^6 , to set the knives k , in any desired angular adjustment, to vary the spread of the crotch.

For co-operation with the crotch-knives k , I provide reciprocating cutter-bars k^4 , one for each crotch, having each a single diamond shaped cutter k^5 , movable crosswise of the apex of the crotch formed by the knives k . The cutter-bars k^4 , are mounted in boxes k^6 fixed to the frame base, and are operated from a single pitman k^7 , through a common connecting rod or tie-bar k^8 uniting the two cutter-bars. The pitman k^7 is connected to crank-disk k^9 on the pinion shaft k^{10} , mounted in the bearing k^{11} . The said pinion engages with the beveled gear k^{12} , which is loose on the axle a' and provided with a half clutch k^{13} , engageable with the shifting half-clutch k^{14} , also on said shaft. The half clutch k^{14} , is engaged by an ordinary spring-pawl shipper lever k^{15} , pivoted to the fixed sector-bracket k^{16} , and may be operated at will, to throw the beveled gear k^{12} and the parts operated thereby into and out of gear with the main axle.

The single diamond shaped cutters k^5 , for co-operation with the crotch knives k , constitute a material improvement over my prior machines. The single diamond shaped cutter gives a shearing cut throughout its entire stroke, and a drawing one, as well, with respect to the knives k , which is very effective in cutting the stalks, and at the same time tends to clear the crotch. The single cutter is also much more efficient than a series of diamond shaped cutters on a common bar or different bars would be, inasmuch as the single cutter operates in one kerf on the stalks. Two or more cutters would have a haggling action on the stalk in different kerfs. The fact that both of the reciprocating cutters are driven from a single pitman is also an advantage in economy of construction and operation.

The reel n n' n^2 n^{2*} is mounted in the outer

end of a carrier bracket n^3 , which is loosely sleeved on a fixed cross-shaft n^4 . The said carrier has fixed to its inner sleeve a hand-lever n^5 with spring-pawl n^6 engageable with a notched sector n^7 rigid on the shaft n^4 , to hold the carrier n^3 at any point of its pivotal adjustment on the said shaft n^4 . The reel blades are of concave form, both crosswise and lengthwise of the reel-arms. The carrier supporting shaft n^4 has attached thereto the sliding members n^8 of sectional telescoping standards; the fixed members n^9 of which, are secured to the inner surfaces of the vertical plates $c c'$. The sliding sections n^8 work in the fixed sections n^9 as guides, and are provided at their lower ends with spring-latches n^{10} , adapted to engage with any one of a series of holes n^{11} , in the fixed sections n^9 . The fixed sections are slotted longitudinally, as shown at n^{16} , to permit the sliding movement of the outwardly projecting spring-latches n^{10} ; and the sliding sections n^8 are slotted longitudinally, as shown at n^{13} , to permit the movement of the same independent of the clamping-rod d' . The clamping rod d' has collars n^{14} , which engage with the inner surfaces of the sliding sections n^8 , and is provided with nuts n^{15} , engaging the screw-threaded outer ends of the rod, and working against the side plates $c c$, to tightly clamp the said standard sections together and to the main frame in whatever position they may be set. It is obvious, that by loosening the nuts n^{15} and pulling outward the spring-latch n^{10} , that the sliding sections n^8 may be raised or lowered on the fixed sections n^9 , to any position which may be desired for the proper vertical adjustment of the reel carrier shaft n^4 and the reel carrier n^3 .

With the construction so far described, the reel may be set at any desired height and be given any desired angular dip, which may be required for best adapting the same to its work. But the hills of corn or the stalks, if drilled, are bound to be more or less unevenly spaced apart in the rows. Hence, as the reel must be driven directly or indirectly from the ground wheels, the timing of its blade strokes on the corn is liable to be thrown out, more or less, by the uneven spaces, and this is liable to be, to a greater or less extent, cumulative. To overcome this difficulty, I provide a reel-drive, which contains as one of its elements a clutch, the driven member of which may be thrown forward on the driving member, at will, in order to change the timing of the reel-strokes, with respect to the travel of the machine, as required for the proper action on the unequally spaced hills of corn.

I have shown a chain and sprocket drive, comprising the sprocket n^{16} on the same hub with the main driving gear k^{12} ; a chain n^{17} from sprocket n^{16} to a sprocket n^{18} loose on the reel-carrier shaft n^4 and having a half clutch n^{19} ; a sprocket n^{20} also loose on the said shaft n^4 and having a half clutch n^{21} engaging with the half clutch n^{19} ; and a chain

n^{22} from the sprocket n^{20} to either one of two interchangeable sprockets n^{23} , mounted on a common shifting hub n^{24} , adapted to be rigidly secured to the reel-shaft n' by set-screw n^{25} . The two loose sprockets n^{20}, n^{18} are under tension from a spring n^{26} , which tends to hold the two half-clutch members in engagement with each other. On the shaft n^4 is loosely sleeved a hanger n^{27} , having a hand operated pawl-lever n^{28} pivoted thereto, the pawl portion of which is engageable with a ratchet n^{29} cut on one hub of the sprocket n^{20} . It is obvious, that by operating the pawl-lever n^{28} , that the driven half clutch member n^{21} and the sprocket n^{20} may be thrown forward, with respect to the driving clutch member n^{19} and sprocket n^{18} . Hence, the timing of the reel-blade strokes may be adjusted, at will, by simply operating the pawl lever n^{28} . The dumping tables or bundle-carriers p have trunnions p' , journaled in the outwardly projecting parts b' and b'' of the frame-base. The trunnions p' are located inward of the transverse centers of the said tables. The said tables p are provided, at points inward of their trunnions and near their longitudinal centers, with spring-seated staples p^2 mounted in guides or box-like seats p^3 secured between the under surfaces of the tables and cross-straps p^4 having inwardly projecting lips p^5 adapted to engage with the under surface of the frame-base, when the tables are in their dumping position. The staples p^2 connect above the tables, with hook-ended crank-arms p^6 rigidly secured to the outer ends of a dumping shaft p^7 having secured thereto a hand-lever p^8 within reach of the driver on the seat g . The lever p^8 is under tension from a spring p^9 to move forward and throw the tables into their uppermost or receiving position; in which positions, the tables may be locked by a foot operated spring-latch p^{10} , pivoted to a collar p^{10a} rigidly secured to the fixed shaft d . The crank arms p^6 have spring snaps p^{6a} . At the outer corners of their forward ends, the tables p are provided with flaring or beveled corner sections p^{11}, p^{12} , which serve the double purpose of marginal boards and cam-surface riders, to lift the tables over any obstacles which may come in their path, when in their dumping position. The action in this respect may be readily understood, by inspection of Figs. 10 and 11. If the table should be in its dumping position, as shown in dotted lines in Fig. 11, and the dumping shaft p^7 be, in anywise, rigidly held, the spring staple p^2 will yield, in case the beveled sections p^{11} or p^{12} should strike a stone or other obstacle, and thus allow the table to rise and readily ride over the same. When the tables p are thrown into their dumping positions, they will be locked therein by the spring-latch p^{10} , unless the operator holds the said latch from its normal action. Hence, the beveled surfaces p^{11}, p^{12} for co-operation with the spring staples p^2 are an important feature of the construction, for

the successful operation of the machine on stony or cloddy ground; or in fields where a crop of pumpkins is grown along with the corn.

The thills r , are secured to the frame base portions b^3 in any suitable way.

The operation of the machine is obvious. Under the forward motion of the same, with the draft animal walking between the two rows of corn, the corn will be gathered into the crotches by the arighting arms and gathering plates and reels, and, under the co-operation of the fixed crotch knives and the reciprocating cutters, will be cut off and be thrown by the reel-blades backward onto the bundle-tables. Whenever the cut corn has accumulated on the tables into bundles of the desired size, the driver operates the foot-latch p^{10} and permits the tables to drop into their dumping position, under the weight of the bundles, against the tension of the springs p^9 , where the latch p^{10} will lock the same until again released by the operator, when the springs p^9 will restore the tables to their uppermost or normal position, where they will again be locked by the latch p^{10} . Whenever the strokes of the reel-blades get out of time, the operator will correct the same by manipulating the pawl lever k^{28} .

In addition to the function of adjusting the reel carrier in the vertical plane, the telescoping sectional standards n^5, n^9 , serve also as a tightener for the sprocket-chain n^{17} . When any considerable adjustment of the reel carrier is made, upward or downward, more or less links would be taken from or added to the sprocket chain n^{17} , which as is well known, may be readily done with the link-belt chains.

What I claim, and desire to secure by Letters Patent of the United States, is as follows:

1. The combination with a reel, of a drive for the same, having as one of its elements, a clutch mechanism, the driven member of which is adapted to be thrown forward on the driving member thereof, to change the timing of the reel stroke, with reference to the travel of the machine, and a hand device operative on said driven member for giving the same its advancing movement with reference to said driving member, substantially as described.

2. The combination with the reel, of a clutch in the drive for the same, and a pawl and ratchet device applied to the driven member of said clutch, for moving the same forward on the driving member to change the timing of the reel stroke, substantially as described.

3. The combination with the reel driving chains n^{17}, n^{22} , of the sprockets n^{18}, n^{20} , loose on the shaft n^4 , provided with the half clutches n^{19} and n^{21} , and under tension from spring n^{26} , as described, the hanger n^{20} , loose on said shaft n^4 , and the pawl lever n^{28} pivoted to said hanger and engageable with the ratchet n^{29} on the hub of the sprocket n^{20} , substantially as described.

4. The combination with the supporting shaft n^4 , for the reel carrier, of the pair of standard sections n^9 fixed to the machine frame, having the series of holes n^{11} and the slots n^{12} , the sliding standard sections n^8 , working in said guide sections, having the spring latches n^{10} and the slots n^{13} , and the clamping rod d' with the collars n^{14} and draw nuts n^{15} , all arranged and operating substantially as and for the purpose set forth. 10

In testimony whereof I affix my signature in presence of two witnesses.

RASMUS PEDERSON.

Witnesses:

GRANT MATTHEWS,

EDWIN POWDERLY.