

(19) World Intellectual Property Organization
International Bureau



(43) International Publication Date
13 January 2011 (13.01.2011)

PCT

(10) International Publication Number
WO 2011/006113 A1

(51) International Patent Classification:
A61M 5/00 (2006.01)

(21) International Application Number:
PCT/US2010/041589

(22) International Filing Date:
9 July 2010 (09.07.2010)

(25) Filing Language: English

(26) Publication Language: English

(30) Priority Data:
61/224,158 9 July 2009 (09.07.2009) US

(71) Applicant (for all designated States except US): **IVANTIS, INC.** [US/US]; 13766 Alton Parkway, Suite 150, Irvine, CA 92618 (US).

(72) Inventors; and

(75) Inventors/Applicants (for US only): **WARDLE, John** [US/US]; 13766 Alton Parkway, Suite 150, Irvine, CA 92618 (US). **SCHIEBER, Andrew, T.** [US/US]; 13766 Alton Parkway, Suite 150, Irvine, CA 92618 (US). **GALT, Kenneth, M.** [US/US]; 13766 Alton Parkway, Suite 150, Irvine, CA 92618 (US).

(74) Agents: **THOMAS, Justin** et al.; SHAY GLENN LLP, 2755 Campus Drive, Suite 210, San Mateo, CA 94403 (US).

(81) Designated States (unless otherwise indicated, for every kind of national protection available): AE, AG, AL, AM, AO, AT, AU, AZ, BA, BB, BG, BH, BR, BW, BY, BZ, CA, CH, CL, CN, CO, CR, CU, CZ, DE, DK, DM, DO, DZ, EC, EE, EG, ES, FI, GB, GD, GE, GH, GM, GT, HN, HR, HU, ID, IL, IN, IS, JP, KE, KG, KM, KN, KP, KR, KZ, LA, LC, LK, LR, LS, LT, LU, LY, MA, MD, ME, MG, MK, MN, MW, MX, MY, MZ, NA, NG, NI, NO, NZ, OM, PE, PG, PH, PL, PT, RO, RS, RU, SC, SD, SE, SG, SK, SL, SM, ST, SV, SY, TH, TJ, TM, TN, TR, TT, TZ, UA, UG, US, UZ, VC, VN, ZA, ZM, ZW.

(84) Designated States (unless otherwise indicated, for every kind of regional protection available): ARIPO (BW, GH, GM, KE, LR, LS, MW, MZ, NA, SD, SL, SZ, TZ, UG, ZM, ZW), Eurasian (AM, AZ, BY, KG, KZ, MD, RU, TJ, TM), European (AL, AT, BE, BG, CH, CY, CZ, DE, DK, EE, ES, FI, FR, GB, GR, HR, HU, IE, IS, IT, LT, LU, LV, MC, MK, MT, NL, NO, PL, PT, RO, SE, SI, SK, SM, TR), OAPI (BF, BJ, CF, CG, CI, CM, GA, GN, GQ, GW, ML, MR, NE, SN, TD, TG).

Published:

— with international search report (Art. 21(3))

(54) Title: OCULAR IMPLANTS AND METHODS FOR DELIVERING OCULAR IMPLANTS INTO THE EYE

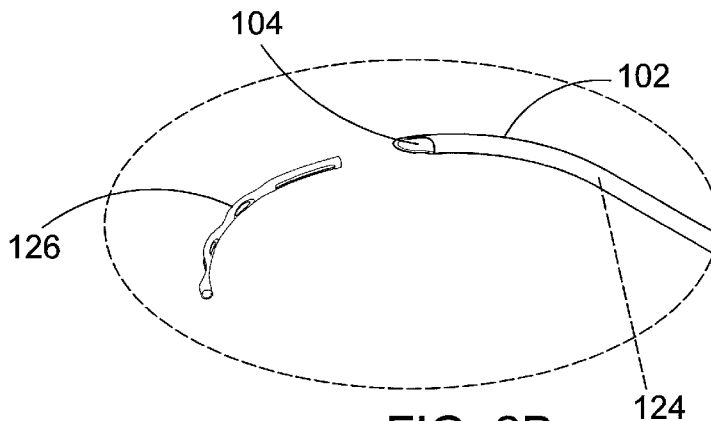

FIG. 2B

(57) Abstract: An ocular implant is provided. In some embodiments, the ocular implant includes a body that is curved about a longitudinal central axis and a distal body portion that defines a longitudinal channel including a channel opening. The implant is sized and configured such that the ocular implant assumes an orientation in which the channel opening is adjacent a major side of Schlemm's canal when the ocular implant is disposed in Schlemm's canal. Methods for delivering ocular implants into Schlemm's canal are also provided. Some methods include covering openings in the ocular implant, advancing the implant into Schlemm's canal while at least some of the openings are covered, and uncovering the openings while the distal portion of the implant is disposed in Schlemm's canal.



WO 2011/006113 A1

OCULAR IMPLANTS AND METHODS FOR DELIVERING OCULAR IMPLANTS INTO THE EYE

CROSS REFERENCE TO RELATED APPLICATIONS

5 [0001] This application claims the benefit under 35 U.S.C. 119 of U.S. Provisional Patent Application No. 61/224,158, filed July 9, 2009, titled "Sheathed Ocular Implant and Delivery System". This application is herein incorporated by reference in its entirety.

INCORPORATION BY REFERENCE

10 [0002] All publications and patent applications mentioned in this specification are herein incorporated by reference to the same extent as if each individual publication or patent application was specifically and individually indicated to be incorporated by reference.

FIELD OF THE INVENTION

15 [0003] The present invention relates generally to devices that are implanted within the eye. More particularly, the present invention relates to systems, devices and methods for delivering ocular implants into the eye.

BACKGROUND OF THE INVENTION

20 [0004] According to a draft report by The National Eye Institute (NEI) at The United States National Institutes of Health (NIH), glaucoma is now the leading cause of irreversible blindness worldwide and the second leading cause of blindness, behind cataract, in the world. Thus, the NEI draft report concludes, "it is critical that significant emphasis and resources continue to be devoted to determining the pathophysiology and management of this disease." Glaucoma
25 researchers have found a strong correlation between high intraocular pressure and glaucoma. For this reason, eye care professionals routinely screen patients for glaucoma by measuring intraocular pressure using a device known as a tonometer. Many modern tonometers make this measurement by blowing a sudden puff of air against the outer surface of the eye.

[0005] The eye can be conceptualized as a ball filled with fluid. There are two types of fluid
30 inside the eye. The cavity behind the lens is filled with a viscous fluid known as vitreous humor. The cavities in front of the lens are filled with a fluid known as aqueous humor. Whenever a person views an object, he or she is viewing that object through both the vitreous humor and the aqueous humor.

[0006] Whenever a person views an object, he or she is also viewing that object through the cornea and the lens of the eye. In order to be transparent, the cornea and the lens can include no blood vessels. Accordingly, no blood flows through the cornea and the lens to provide nutrition to these tissues and to remove wastes from these tissues. Instead, these functions are performed
5 by the aqueous humor. A continuous flow of aqueous humor through the eye provides nutrition to portions of the eye (e.g., the cornea and the lens) that have no blood vessels. This flow of aqueous humor also removes waste from these tissues.

[0007] Aqueous humor is produced by an organ known as the ciliary body. The ciliary body includes epithelial cells that continuously secrete aqueous humor. In a healthy eye, a stream of
10 aqueous humor flows out of the anterior chamber of the eye through the trabecular meshwork and into Schlemm's canal as new aqueous humor is secreted by the epithelial cells of the ciliary body. This excess aqueous humor enters the venous blood stream from Schlemm's canal and is carried along with the venous blood leaving the eye.

[0008] When the natural drainage mechanisms of the eye stop functioning properly, the
15 pressure inside the eye begins to rise. Researchers have theorized prolonged exposure to high intraocular pressure causes damage to the optic nerve that transmits sensory information from the eye to the brain. This damage to the optic nerve results in loss of peripheral vision. As glaucoma progresses, more and more of the visual field is lost until the patient is completely blind.

[0009] In addition to drug treatments, a variety of surgical treatments for glaucoma have
20 been performed. For example, shunts were implanted to direct aqueous humor from the anterior chamber to the extraocular vein (Lee and Scheppens, "Aqueous-venous shunt and intraocular pressure," *Investigative Ophthalmology* (Feb. 1966)). Other early glaucoma treatment implants led from the anterior chamber to a sub-conjunctival bleb (e.g., US 4,968,296 and US 5,180,362).
25 Still others were shunts leading from the anterior chamber to a point just inside Schlemm's canal (Spiegel et al., "Schlemm's canal implant: a new method to lower intraocular pressure in patients with POAG?" *Ophthalmic Surgery and Lasers* (June 1999); US 6,450,984; US 6,450,984).

SUMMARY OF THE DISCLOSURE

[00010] The invention pertains to aspects of ocular implants, ocular implant delivery systems,
30 and methods for delivering ocular implants. One aspect of the invention an ocular implant adapted to reside at least partially in a portion of Schlemm's canal of an eye. In some embodiments, the ocular implant includes a body having a first major surface and a second major surface, the body being curved about a longitudinal central axis so that the first major surface
35 comprises a concave surface and the second major surface comprises a convex surface, a distal

portion of the body defining a longitudinal channel including a channel opening, the channel opening being disposed diametrically opposite a central portion of the concave surface, and the body being adapted and configured such that the ocular implant assumes an orientation in which the channel opening is adjacent a major side of Schlemm's canal when the ocular implant is disposed in Schlemm's canal. The channel may opens away from the pupil of the when the channel opening is adjacent an outer major side of Schlemm's canal.

[00011] In some embodiments, the channel has a width and a depth and an aspect ratio of the width to the depth is such that the ocular implant assumes an orientation in which the channel opening is adjacent a major side of Schlemm's canal when the ocular implant is disposed in Schlemm's canal. In some useful embodiments, the aspect ratio of channel width WD to channel depth DP is greater than about one. In some particularly useful embodiments, the aspect ratio of channel width WD to channel depth DP is about two. In some useful embodiments, the aspect ratio of channel width WD to channel depth DP is greater than about two.

[00012] In some embodiments, the body has a first lateral extent, a second lateral extent, and a longitudinal length and an aspect ratio of the first lateral extent to the second lateral extent is such that the ocular implant assumes an orientation in which the channel opening is adjacent a major side of Schlemm's canal when the ocular implant is disposed in Schlemm's canal. In some useful embodiments, an aspect ratio of first lateral extent EF to second lateral extent ES is greater than about one. In some particularly useful embodiments, the aspect ratio of first lateral extent EF to second lateral extent ES is about two. In some useful embodiments, the aspect ratio of first lateral extent EF to second lateral extent ES is greater than about two.

[00013] In some embodiments, a distal portion of the body of the ocular implant extends across an angular span of less than 180 degrees as the body curves about the longitudinal central axis. In some embodiments, the body defines additional openings fluidly communicating with the channel and the body of the implant is more than 50% open due to the openings defined by the body. In some embodiments, the body of the ocular implant has a diameter of between about 0.005 inches and about 0.04 inches.

[00014] In some embodiments, the ocular implant comprises a therapeutic agent deposited on the body. In some of these embodiments, a therapeutic agent comprises an anti-glaucoma drug. The anti-glaucoma drug comprises a prostaglandin analog in some embodiments. The prostaglandin analog comprises latanprost in some embodiments.

[00015] In some embodiments, the body of the ocular implant has a thickness extending between the concave surface and the convex surface. The thickness of the body is substantially uniform along a length of the body in some embodiments. In some embodiments, the thickness of the body is substantially uniform along a circumference of the body.

[00016] In some embodiments, the body is curved about a lateral central axis so that a longitudinal axis of the body defines a plane. When this is the case, the body has a lateral radius of curvature extending between the lateral central axis and an outer extent of the body. The lateral radius of curvature is substantially constant in some embodiments. In other embodiments, the lateral radius of curvature varies along a length of the body.

[00017] Another aspect of the invention provides an ocular implant system for treating an eye. In some embodiments, the ocular implant system comprises a delivery cannula comprising a tubular member defining a distal opening, a proximal opening, and a passageway extending between the proximal opening and the distal opening. In some embodiments, the delivery cannula includes a curved portion disposed between the distal opening and the proximal opening, the delivery cannula being adapted and configured such that the distal opening can be placed in fluid communication with Schlemm's canal when the cannula is extending through the cornea of the eye and the curved portion of the cannula is at least partially disposed in the anterior chamber of the eye. In some embodiments, the implant system includes an ocular implant disposed in the passageway defined by the delivery cannula, the ocular implant comprising a body having a first major surface and a second major surface, the body being curved about a longitudinal central axis so that the first major surface comprises a concave surface and the second major surface comprises a convex surface, a distal portion of the body defining a longitudinal channel including a channel opening. In some useful embodiments, the ocular implant is oriented relative to the delivery cannula such that the channel of the ocular implant opens in a radially outward direction when the ocular implant passes through the curved portion of the delivery cannula.

[00018] An additional aspect of the invention provides another ocular implant system for treating an eye. In some embodiments, the ocular implant system comprises an ocular implant defining a plurality of openings and a sheath disposed about the body of the ocular implant. In some embodiments, the sheath covers at least some of the openings and the sheath is adapted and configured such that the sheath can be selectively removed from the body for uncovering the openings.

[00019] In some embodiments, the sheath comprises a proximal portion defining a lumen and a distal portion defining a distal aperture, the lumen having a lumen width and the distal aperture having an aperture width. The aperture width is smaller than the lumen width in some embodiments. The distal portion provides a transition from the lumen width to the aperture width in some embodiments. In some embodiments, the lumen width is equal to or greater than a width of the implant and the aperture width is smaller than the width of the implant.

[00020] In some embodiments, the distal portion of the sheath comprises a first region, a second region, and a slit disposed between the first region and the second region. The sheath includes a frangible connection between the first region and the second region in some embodiments. In some embodiments, the frangible connection comprises a bridge extending
5 across the slit. The aperture width of the distal aperture may become larger when the frangible connection is broken.

[00021] In some embodiments, the distal portion of the sheath has a first hoop strength, the proximal portion of the sheath has a second hoop strength, and the second hoop strength is greater than the first hoop strength. The hoop strength of the distal portion is limited by the
10 frangible connection in some embodiments.

[00022] In some embodiments, the distal portion of the sheath extends beyond a distal end of the implant. The frangible connection breaks when the sheath is moved in a proximal direction relative to the implant in some embodiments. The distal portion of the sheath has a tapered shape in some embodiments. In other embodiments, the distal portion of the sheath has a blunt
15 shape.

[00023] In some embodiments, the ocular implant system may include a core resting in the longitudinal channel of the implant and a push tube contacting a proximal end of the implant. The core, the push tube, and the sheath extend into a lumen defined by a cannula in some
20 embodiments. The implant may be disposed in a lumen defined by the cannula.

[00024] Yet another aspect of the invention provides a method of deploying an ocular implant into Schlemm's canal of a human eye. In some embodiments, the method includes providing an ocular implant comprising a body having a first major surface and a second major surface, the body being curved about a longitudinal central axis so that the first major surface comprises a concave surface and the second major surface comprises a convex surface, a distal portion of the
25 body defining a longitudinal channel including a channel opening, the body defining additional openings fluidly communicating with the channel. The method may include the following steps: covering at least some of the openings; advancing at least a distal portion of the implant into Schlemm's canal while at least some of the openings are covered; and uncovering at least some of the openings while the distal portion of the implant is disposed in Schlemm's canal. In some
30 embodiments, the method includes orienting the ocular implant so that the channel opening is adjacent an outer major side of Schlemm's canal.

[00025] In some embodiments, covering at least some of the apertures comprises positioning a sheath over at least a portion of the implant and uncovering at least some of the apertures comprises moving the sheath in a proximal direction relative to the implant. Uncovering at least
35 some of the apertures comprises breaking a frangible portion of the sheath in some embodiments.

The frangible portion of the sheath may be broken, for example, when the sheath is moved in a proximal direction relative to the implant. Moving the sheath in a proximal direction relative to the implant may be accomplished by, for example, applying a proximal directed force to the sheath while applying a distally directed reaction force on the implant. Applying a distally directed reaction force on the implant may be accomplished by, for example, pushing on a proximal end of the implant with a push tube.

10

BRIEF DESCRIPTION OF THE DRAWINGS

[00026] Figure 1 is a stylized representation of a medical procedure in accordance with this detailed description.

15

[00027] Figure 2A is a perspective view further illustrating a delivery system 100 used in the medical procedure shown in the previous Figure. Figure 2B is an enlarged detail view further illustrating a cannula of the delivery system shown in the previous Figure.

[00028] Figure 3 is a stylized perspective view illustrating the anatomy of an eye.

[00029] Figure 4 is a stylized perspective view showing Schlemm's canal and an iris of the eye shown in the previous Figure.

20

[00030] Figure 5 is an enlarged cross-sectional view further illustrating Schlemm's canal SC shown in the previous Figure.

[00031] Figure 6 is a perspective view showing an ocular implant in accordance with this detailed description.

[00032] Figure 7A and Figure 7B are section views showing an ocular implant disposed in Schlemm's canal of an eye.

25

[00033] Figure 8A, Figure 8B and Figure 8C are multiple plan views illustrating an implant in accordance with the present detailed description.

[00034] Figure 9 is a lateral cross-sectional view of an ocular implant taken along section line A-A shown in the previous Figure.

30

[00035] Figure 10A is a perspective view of an ocular implant and Figure 10B is a stylized perspective view showing Schlemm's canal SC encircling an iris.

[00036] Figure 11A is a perspective view showing a delivery system 100 that may be used to advance an ocular implant into Schlemm's canal of an eye. Figure 11B is an enlarged detail view illustrating a cannula portion of the delivery system.

35

[00037] Figure 12 is an enlarged perspective view of an assembly including a cannula, an ocular implant, and a sheath.

[00038] Figure 13 is an additional perspective view of the assembly shown in the previous Figure.

[00039] Figure 14 is another perspective view of an assembly including a cannula, an ocular implant, and a sheath.

5 [00040] Figure 15 is an additional perspective view of the assembly shown in the previous Figure.

[00041] Figure 16A and Figure 16B are perspective views showing a sheath in accordance with the present detailed description.

10 [00042] Figure 17 is a perspective view of an assembly including the sheath shown in the previous Figure.

[00043] Figure 18A and Figure 18B are simplified plan views showing a sheath in accordance with the present detailed description.

[00044] Figure 19A, Figure 19B and Figure 19C are plan views showing an implant in accordance with the present detailed description.

15 [00045] Figure 20 is a lateral cross-sectional view of an ocular implant taken along section line A-A shown in the previous Figure.

[00046] Figure 21 is a plan view showing an implant in accordance with the present detailed description.

20 [00047] Figure 22A, Figure 22B and Figure 22C are plan views showing an additional implant in accordance with the present detailed description.

[00048] Figure 23 is a lateral cross-sectional view of an ocular implant taken along section line B-B shown in the previous Figure.

[00049] Figure 24 is a plan view showing an implant in accordance with the present detailed description.

25 [00050] Figure 25A through Figure 25D are a series of plan views illustrating a method in accordance with the present detailed description.

[00051] Figure 26A through Figure 26D are a series of section views illustrating a method in accordance with the present detailed description.

30 [00052] Figure 27A and Figure 27B are simplified plan views showing a sheath in accordance with the present detailed description.

DETAILED DESCRIPTION OF THE INVENTION

[00053] The following detailed description should be read with reference to the drawings in which similar elements in different drawings are numbered the same. The drawings, which are

not necessarily to scale, depict illustrative embodiments and are not intended to limit the scope of the invention.

[00054] Figure 1 is a stylized representation of a medical procedure in accordance with this detailed description. In the procedure of Figure 1, a physician is treating an eye 20 of a patient P. In the procedure of Figure 1, the physician is holding a delivery system 100 in his or her right hand RH. The physician's left hand (not shown) may be used to hold the handle H of a gonio lens 23. It will be appreciated that some physician's may prefer holding the delivery system handle in the left hand and the gonio lens handle H in the right hand RH.

[00055] During the procedure illustrated in Figure 1, the physician may view the interior of the anterior chamber using gonio lens 23 and a microscope 25. Detail A of Figure 1 is a stylized simulation of the image viewed by the physician. A distal portion of a cannula 102 is visible in Detail A. A shadow-like line indicates the location of Schlemm's canal SC which is lying under various tissue (e.g., the trabecular meshwork) that surround the anterior chamber. A distal opening 104 of cannula 102 is positioned near Schlemm's canal SC of eye 20. In some methods in accordance with this detailed description, distal opening 104 of cannula 102 is placed in fluid communication with Schlemm's canal SC. When this is the case, an ocular implant may be advanced through distal opening 104 and into Schlemm's canal SC.

[00056] Figure 2A is a perspective view further illustrating delivery system 100 and eye 20 shown in the previous Figure. In Figure 2A, cannula 102 of delivery system 100 is shown extending through a cornea 40 of eye 20. A distal portion of cannula 102 is disposed inside the anterior chamber defined by cornea 40 of eye 20. In the embodiment of Figure 2A, cannula 102 is configured so that a distal opening 104 of cannula 102 can be placed in fluid communication with Schlemm's canal.

[00057] In the embodiment of Figure 2A, an ocular implant is disposed in a lumen defined by cannula 102. Delivery system 100 includes a mechanism that is capable of advancing and retracting the ocular implant along the length of cannula 102. The ocular implant may be placed in Schlemm's canal of eye 20 by advancing the ocular implant through distal opening 104 of cannula 102 while distal opening 104 is in fluid communication with Schlemm's canal.

[00058] Figure 2B is an enlarged detail view further illustrating cannula 102 of delivery system 100. In the illustrative embodiment of Figure 2B, an ocular implant 126 has been advanced through distal opening 104 of cannula 102. Cannula 102 of Figure 2B defines a passageway 124 that fluidly communicates with distal opening 104. Ocular implant 126 may be moved along passageway 124 and through distal opening by delivery system 100. Delivery system 100 includes a mechanism capable of performing this function.

[00059] Figure 3 is a stylized perspective view illustrating a portion of eye 20 discussed above. Eye 20 includes an iris 30 defining a pupil 32. In Figure 3, eye 20 is shown as a cross-sectional view created by a cutting plane passing through the center of pupil 32. Eye 20 can be conceptualized as a fluid filled ball having two chambers. Sclera 34 of eye 20 surrounds a posterior chamber PC filled with a viscous fluid known as vitreous humor. Cornea 36 of eye 20 encloses an anterior chamber AC that is filled with a fluid known as aqueous humor. The cornea 36 meets the sclera 34 at a limbus 38 of eye 20. A lens 40 of eye 20 is located between anterior chamber AC and posterior chamber PC. Lens 40 is held in place by a number of ciliary zonules 42.

[00060] Whenever a person views an object, he or she is viewing that object through the cornea, the aqueous humor, and the lens of the eye. In order to be transparent, the cornea and the lens can include no blood vessels. Accordingly, no blood flows through the cornea and the lens to provide nutrition to these tissues and to remove wastes from these tissues. Instead, these functions are performed by the aqueous humor. A continuous flow of aqueous humor through the eye provides nutrition to portions of the eye (e.g., the cornea and the lens) that have no blood vessels. This flow of aqueous humor also removes waste from these tissues.

[00061] Aqueous humor is produced by an organ known as the ciliary body. The ciliary body includes epithelial cells that continuously secrete aqueous humor. In a healthy eye, a stream of aqueous humor flows out of the eye as new aqueous humor is secreted by the epithelial cells of the ciliary body. This excess aqueous humor enters the blood stream and is carried away by venous blood leaving the eye.

[00062] Schlemm's canal SC is a tube-like structure that encircles iris 30. Two laterally cut ends of Schlemm's canal SC are visible in the cross-sectional view of Figure 3. In a healthy eye, aqueous humor flows out of anterior chamber AC and into Schlemm's canal SC. Aqueous humor exits Schlemm's canal SC and flows into a number of collector channels. After leaving Schlemm's canal SC, aqueous humor is absorbed into the venous blood stream and carried out of the eye.

[00063] Figure 4 is a stylized perspective view showing Schlemm's canal SC and iris 30 of eye 20 shown in the previous Figure. In Figure 4, Schlemm's canal SC is shown encircling iris 30. With reference to Figure 4, it will be appreciated that Schlemm's canal SC may overhang iris 30 slightly. Iris 30 defines a pupil 32. In the embodiment of Figure 4, Schlemm's canal SC and iris 30 are shown in cross-section, with a cutting plane passing through the center of pupil 32.

[00064] The shape of Schlemm's canal SC is somewhat irregular, and can vary from patient to patient. The shape of Schlemm's canal SC may be conceptualized as a cylindrical-tube that has been partially flattened. With reference to Figure 4, it will be appreciated that Schlemm's canal

SC has a first major side 50, a second major side 52, a first minor side 54, and a second minor side 56.

[00065] Schlemm's canal SC forms a ring around iris 30 with pupil 32 disposed in the center of that ring. With reference to Figure 4, it will be appreciated that first major side 50 is on the outside of the ring formed by Schlemm's canal SC and second major side 52 is on the inside of the ring formed by Schlemm's canal SC. Accordingly, first major side 50 may be referred to as an outer major side of Schlemm's canal SC and second major side 52 may be referred to as an inner major side of Schlemm's canal SC. With reference to Figure 4, it will be appreciated that first major side 50 is further from pupil 32 than second major side 52.

[00066] Figure 5 is an enlarged cross-sectional view further illustrating Schlemm's canal SC shown in the previous Figure. With reference to Figure 5, it will be appreciated that Schlemm's canal SC comprises a wall W defining a lumen 58. The shape of Schlemm's canal SC is somewhat irregular, and can vary from patient to patient. The shape of Schlemm's canal SC may be conceptualized as a cylindrical-tube that has been partially flattened. The cross-sectional shape of lumen 58 may be compared to the shape of an ellipse. A major axis 60 and a minor axis 62 of lumen 58 are illustrated with dashed lines in Figure 5.

[00067] The length of major axis 60 and minor axis 62 can vary from patient to patient. The length of minor axis 62 is between one and thirty micrometers in most patients. The length of major axis 60 is between one hundred and fifty micrometers and three hundred and fifty micrometers in most patients.

[00068] With reference to Figure 5, it will be appreciated that Schlemm's canal SC comprises a first major side 50, a second major side 52, a first minor side 54, and a second minor side 56. In the embodiment of Figure 5, first major side 50 is longer than both first minor side 54 and second minor side 56. Also in the embodiment of Figure 5, second major side 52 is longer than both first minor side 54 and second minor side 56.

[00069] Figure 6 is a perspective view showing an ocular implant in accordance with this detailed description. Ocular implant 126 of Figure 6 comprises a body 128 that extends along a generally curved longitudinal central axis 148. In the embodiment of Figure 6, body 128 has a radius of curvature R that is represented with an arrow extending between a lateral central axis 176 and body 128.

[00070] Body 128 of ocular implant 126 has a first major surface 130 and a second major surface 132. With reference to Figure 6, it will be appreciated that body 128 is curved about longitudinal central axis 148 so that first major surface 130 comprises a concave surface 136 and second major surface 132 comprises a convex surface 134. The curvature of body 128 can be pre-sized and configured to align with the curvature of Schlemm's canal in a patient's eye.

[00071] A distal portion of body 128 defines a longitudinal channel 138 including a channel opening 139. Channel opening 139 is disposed diametrically opposite a central portion 135 of concave surface 136. Because of the curvature of the body 128, an outer diameter of the implant defined by the channel opening 139 will be greater than an inner diameter of the implant defined by surface 132. In some embodiments, the body is pre-biased to assume a configuration in which the channel opening 139 is disposed along an outer diameter of the body, ensuring that the channel opening can be positioned adjacent to the first major side 50 of Schlemm's canal.

[00072] In the embodiment of Figure 6, central portion 135 of concave surface 136 defines a plurality of apertures 137. Each aperture 137 fluidly communicates with channel 138. In some useful embodiments, body 128 is adapted and configured such that ocular implant 126 assumes an orientation in which channel opening 139 is adjacent a major side of Schlemm's canal when ocular implant 126 is disposed in Schlemm's canal. Ocular implant 126 can be made, for example, by laser cutting body 128 from a length of metal or a shape memory material (e.g., nitinol or stainless steel) tubing.

[00073] Figure 7A and Figure 7B are section views showing an ocular implant 126 disposed in Schlemm's canal SC of an eye. Figure 7A and Figure 7B may be collectively referred to as Figure 7. The eye of Figure 7 includes an iris 30. A central portion of iris 30 defines a pupil 32. Schlemm's canal SC is disposed near an outer edge of iris 30. The trabecular meshwork TM extends up from the iris of overlays Schlemm's canal SC. The picture plane of Figure 7 extends laterally across Schlemm's canal SC and the trabecular meshwork TM.

[00074] Schlemm's canal SC forms a ring around iris 30 with pupil 32 disposed in the center of that ring. Schlemm's canal SC has a first major side 50, a second major side 52, a first minor side 54, and a second minor side 56. With reference to Figure 7, it will be appreciated that first major side 50 is further from pupil 32 than second major side 52. In the embodiment of Figure 7, first major side 50 is an outer major side of Schlemm's canal SC and second major side 52 is an inner major side of Schlemm's canal SC.

[00075] In the embodiment of Figure 7A, a distal portion of ocular implant 126 is shown resting in Schlemm's canal SC. A proximal portion of ocular implant 126 is shown extending out of Schlemm's canal SC, through trebecular meshwork TM and into anterior chamber AC.

Ocular implant 126 of Figure 7 comprises a body having a first major surface 130 and a second major surface 132. With reference to Figure 6, it will be appreciated that the body of ocular implant 126 is curved about a longitudinal central axis so that first major surface 130 comprises a concave surface and second major surface 132 comprises a convex surface.

[00076] A distal portion of ocular implant 126 defines a longitudinal channel 138 including a channel opening 139. Channel opening 139 is disposed diametrically opposite a central portion

135 of first major surface 130. In the embodiment of Figure 7A, ocular implant 126 is assuming an orientation in which channel opening 139 is adjacent and open to first major side 50 of Schlemm's canal. In the embodiment of Figure 7B, ocular implant 126 is assuming an orientation in which channel opening 139 is adjacent and open to second major side 52 of Schlemm's canal.

5 [00077] Figure 8A, Figure 8B and Figure 8C illustrate multiple plan views of an implant 126 in accordance with the present detailed description. Figure 8A, Figure 8B and Figure 8C may be referred to collectively as Figure 8. It is customary to refer to multi-view projections using terms such as front view, top view, and side view. In accordance with this convention, Figure 8A may be referred to as a top view of implant 126, Figure 8B may be referred to as a side view of implant 126, and Figure 8C may be referred to as a bottom view of implant 126. The terms top view, side view, and bottom view are used herein as a convenient method for differentiating between the views shown in Figure 8. It will be appreciated that the implant shown in Figure 8 may assume various orientations without deviating from the spirit and scope of this detailed description. Accordingly, the terms top view, side view, and bottom view should not be interpreted to limit the scope of the invention recited in the attached claims.

10 [00078] Ocular implant 126 of Figure 8 comprises a body 128 that extends along a longitudinal central axis 148. Body 128 of ocular implant 126 has a first major surface 130 and a second major surface 132. In the embodiment of Figure 8, body 128 is curved about longitudinal central axis 148 so that first major surface 130 comprises a concave surface 136 and second major surface 132 comprises a convex surface 134.

20 [00079] A distal portion of body 128 defines a longitudinal channel 138 including a channel opening 139. Channel opening 139 is disposed diametrically opposite a central portion 135 of concave surface 136. In the embodiment of Figure 8, central portion 135 of concave surface 136 defines a plurality of apertures 137. Each aperture 137 fluidly communicates with channel 138. In some useful embodiments, body 128 is adapted and configured such that ocular implant 126 assumes an orientation in which channel opening 139 is adjacent a major side of Schlemm's canal when ocular implant 126 is disposed in Schlemm's canal.

25 [00080] Figure 9 is a lateral cross-sectional view of ocular implant 126 taken along section line A-A shown in the previous Figure. Ocular implant 126 comprises a body 128 having a first major surface 130 and a second major surface 132. With reference to Figure 9, it will be appreciated that body 128 curves around a longitudinal central axis 148 so that first major surface 130 comprises a concave surface 136 and second major surface 132 comprises a convex surface 134. The concave surface 136 of body 128 defines a longitudinal channel 138 having a channel opening 139.

[00081] As shown in Figure 9, channel 138 has a width WD and a depth DP. Body 128 of ocular implant 126 has a first lateral extent EF and a second lateral extent ES. In some cases, body 128 is adapted and configured such that ocular implant 126 automatically assumes an orientation in which the channel opening is adjacent a major side of Schlemm's canal when
5 ocular implant 126 is disposed in Schlemm's canal. In some useful embodiments, an aspect ratio of first lateral extent EF to second lateral extent ES is greater than about one. In some particularly useful embodiments, the aspect ratio of first lateral extent EF to second lateral extent ES is about two. In some useful embodiments, the aspect ratio of first lateral extent EF to second lateral extent ES is greater than about two. In some useful embodiments, an aspect ratio
10 of channel width WD to channel depth DP is greater than about one. In some particularly useful embodiments, the aspect ratio of channel width WD to channel depth DP is about two. In some useful embodiments, the aspect ratio of channel width WD to channel depth DP is greater than about two.

[00082] Figure 10A is a perspective view of an ocular implant 126 and Figure 10B is a stylized perspective view showing Schlemm's canal SC encircling an iris 30. Figure 10A and Figure 10B may be collectively referred to as Figure 10. With reference to Figure 10B, it will be appreciated that Schlemm's canal SC may overhang iris 30 slightly. Iris 30 defines a pupil 32. Schlemm's canal SC forms a ring around iris 30 with pupil 32 disposed in the center of that ring. With reference to Figure 10B, it will be appreciated that Schlemm's canal SC has a first major
15 side 50, a second major side 52, a first minor side 54, and a second minor side 56. With reference to Figure 10B, it will be appreciated that first major side 50 is further from pupil 32 than second major side 52. In the embodiment of Figure 10B, first major side 50 is an outer major side of Schlemm's canal SC and second major side 52 is an inner major side of Schlemm's canal SC.
20

[00083] For purposes of illustration, a window 70 is cut through first major side 50 of Schlemm's canal SC in Figure 10B. Through window 70, an ocular implant 126 can be seen residing in a lumen defined by Schlemm's canal. Ocular implant 126 of Figure 10 comprises a body 128 having a first major surface 130. First major surface 130 of body 128 comprises a concave surface 136. Body 128 defines a longitudinal channel 138 including a channel opening
25 139. Channel opening 139 is disposed diametrically opposite a central portion 135 of concave surface 136. In the embodiment of Figure 10B, ocular implant 126 is assuming an orientation in which channel opening 139 is adjacent first major side 50 of Schlemm's canal.
30

[00084] Figure 11A is a perspective view showing a delivery system 100 that may be used to advance an ocular implant 126 into Schlemm's canal of an eye. Delivery system 100 includes a cannula 102 that is coupled to a handle H. Cannula 102 defines a distal opening 104. The distal
35

portion of cannula 102 of delivery system 100 is configured and adapted to be inserted into the anterior chamber of a human subject's eye so that distal opening 104 is positioned near Schlemm's canal of the eye. Cannula 102 is sized and configured so that the distal end of cannula 102 can be advanced through the trabecular meshwork of the eye and into Schlemm's canal. Positioning cannula 102 in this way places distal opening 104 in fluid communication with Schlemm's canal.

[00085] In the embodiment of Figure 11A, an ocular implant is disposed in a passageway defined by cannula 102. Delivery system 100 includes a mechanism that is capable of advancing and retracting the ocular implant along the length of cannula 102. The ocular implant may be placed in Schlemm's canal of eye 20 by advancing the ocular implant through distal opening 104 of cannula 102 while distal opening 104 is in fluid communication with Schlemm's canal.

[00086] Figure 11B is an enlarged detail view further illustrating cannula 102 of delivery system 100. With reference to Figure 11B, it will be appreciated that cannula 102 comprises a tubular member defining a distal opening 104, a proximal opening 105, and a passageway 124 extending between proximal opening 105 and distal opening 104. With reference to Figure 11B, it will be appreciated that cannula 102 includes a curved portion 107 disposed between distal opening 104 and proximal opening 105.

[00087] In the embodiment of Figure 11B, an ocular implant 126 is disposed in passageway 124 defined by cannula 102. Ocular implant 126 of Figure 11B comprises a body 128 that extends along a generally curved longitudinal central axis 148. Body 128 of ocular implant 126 has a first major surface 130 and a second major surface 132. With reference to Figure 11B, it will be appreciated that body 128 is curved about longitudinal central axis 148 so that first major surface 130 defines a longitudinal channel 138 and second major surface 132 comprises a convex surface 134. Longitudinal channel 138 includes a channel opening 139. Ocular implant 126 is orient relative to delivery cannula 102 such that longitudinal channel 138 of ocular implant 126 opens in a radially outward direction RD when ocular implant 126 is disposed in curved portion 107. Radially outward direction RD is illustrated using an arrow in Figure 11B. Distal opening 104 of cannula 102 may be placed in fluid communication with Schlemm's canal of an eye. Implant 126 may be advanced through distal opening 104 and into Schlemm's canal while assuming the orientation shown in Figure 11B. When this is the case, ocular implant 126 may be oriented such that channel opening 139 is adjacent an outer major side of Schlemm's canal when ocular implant 126 is disposed in Schlemm's canal.

[00088] Figure 12 is an enlarged perspective view of an assembly 106 including an ocular implant 126, a sheath 120, and a cannula 102. For purposes of illustration, cannula 102 is cross-sectionally illustrated in Figure 12. In the embodiment of Figure 12, a sheath 120 is shown

extending into a passageway 124 defined by cannula 102. In Figure 12, sheath 120 is illustrated in a transparent manner with a pattern of dots indicating the presence of sheath 120.

[00089] With reference to Figure 12, it will be appreciated that an implant 126 is disposed in a lumen 122 defined by sheath 120. Implant 126 comprises a body 128 having a first major surface 130 and a second major surface 132. In the embodiment of Figure 12, body 128 curves around a longitudinal central axis so that first major surface 130 comprises a concave surface and second major surface 132 comprises a convex surface 134. The concave surface of body 128 defines a longitudinal channel 138. In Figure 12, a core 166 is shown extending through longitudinal channel 138.

[00090] Body 128 of ocular implant 126 defines a plurality of openings 140. In the embodiment of Figure 12, sheath 120 is covering openings 140. With reference to Figure 12, it will be appreciated that sheath 120 comprises a proximal portion 150 defining a lumen 122 and a distal portion 152 defining a distal aperture 154. Core 166 is shown extending through distal aperture 154 in Figure 12. In the embodiment of Figure 12, distal portion 152 of sheath 120 has a generally tapered shape.

[00091] Figure 13 is an additional perspective view of assembly 106 shown in the previous Figure. In Figure 13, core 166, sheath 120, and implant 126 are shown extending through a distal port 104 of cannula 102. Core 166, sheath 120, and implant 126 have been moved in a distal direction relative to the position of those elements shown in the previous Figure.

[00092] A push tube 180 is visible in Figure 13. In Figure 13, a distal end of push tube 180 is shown contacting a proximal end of implant 126. In the embodiment of Figure 13, push tube 180 is disposed in a lumen 122 defined by sheath 120. Sheath 120 comprises a proximal portion 150 defining a passageway 124 and a distal portion 152 defining a distal aperture 154. Implant 126 is disposed in lumen 122 defined by sheath 120. In Figure 13, core 166 is shown extending through a channel 138 defined by implant 126 and a distal aperture 154 defined by distal portion 152 of sheath 120.

[00093] Figure 14 is an additional perspective view showing assembly 106 shown in the previous Figure. With reference to Figure 14, it will be appreciated that implant 126 is disposed outside of cannula 102. In the embodiment of Figure 14, core 166, sheath 120, and push tube 180 have been advanced further so that implant 126 is in a position outside of cannula 102.

[00094] Methods in accordance with the present invention can be used to deliver an implant into Schlemm's canal of an eye. In these methods, a distal portion of core 166 and sheath 120 may be advanced out of the distal port of cannula 102 and into Schlemm's canal. Ocular implant 126 may be disposed inside sheath 120 while the distal portion of the sheath 120 is advanced into

Schlemm's canal. Sheath 120 and core 166 may then be retracted while push tube 180 prevents implant 126 from being pulled proximally.

5 [00095] Figure 15 is an additional perspective view showing the assembly 106 shown in the previous Figure. In the embodiment of Figure 15, core 166 and sheath 120 have been moved in a proximal direction relative to implant 126. With reference to Figure 15, it will be appreciated that implant 126 is now disposed outside of sheath 120. Some methods in accordance with the present detailed description include the step of applying a proximally directed force to sheath 120 and core 166 while providing a distally directed reactionary force on implant 126 to prevent implant 126 from moving proximally. When this is the case, implant 126 may pass through
10 distal aperture 154 of sheath 120 as sheath 120 is retracted over implant 126.

[00096] In the embodiment of Figure 15, distal portion 152 of sheath 120 comprises a first region 156 and a second region 158. The frangible connection between first region 156 and second region 158 has been broken in the embodiment of Figure 15. This frangible connection may be selectively broken, for example, when sheath 120 is moved in a proximal direction
15 relative to implant 126 due to the larger diameter of implant 126 with respect to the diameters of distal portion 152 and opening 154 of sheath 120. With reference to Figure 15, it will be appreciated that the width of distal aperture 154 becomes larger when the frangible connection is broken.

[00097] With reference to the Figures described above, it will be appreciated that methods in
20 accordance with the present detailed description may be used to position a distal portion of an implant in Schlemm's canal of an eye. A method in accordance with the present detailed description may include the step of advancing a distal end of a cannula through a cornea of the eye so that a distal portion of the cannula is disposed in the anterior chamber of the eye. The cannula may be used to access Schlemm's canal, for example, by piercing the wall of Schlemm's
25 canal with a distal portion of the cannula. A distal portion of a sheath may be advanced out of a distal port of the cannula and into Schlemm's canal. An ocular implant may be disposed inside the sheath while the distal portion of the sheath is advanced into Schlemm's canal.

[00098] In some useful methods, the ocular implant comprises a body defining a plurality of apertures and the method includes the step of covering the apertures with a sheath. When this is
30 the case, the distal portion of the implant may be advanced into Schlemm's canal while the apertures are covered by the sheath. Covering the apertures as the implant is advanced into Schlemm's canal may reduce the trauma inflicted on Schlemm's canal by the procedure. The apertures may be uncovered, for example, after the implant has reached a desired location (e.g., inside Schlemm's canal).

[00099] The apertures of the implant may be uncovered, for example, by moving the sheath in a proximal direction relative to the implant. In some applications, this may be accomplished by applying a proximal directed force to the sheath while holding the implant stationary. The implant may be held stationary, for example, by applying a distally directed reaction force on the
5 implant. In one embodiment, a distally directed reaction force is provided by pushing on a proximal end of the implant with a push tube.

[000100] Some methods include the step of ceasing advancement of the sheath into Schlemm's canal when a proximal portion of the implant remains in an anterior chamber of the eye and a distal portion of the implant lies in Schlemm's canal. When this is the case, only a distal portion
10 of the implant is advanced into Schlemm's canal. The portion of the implant extending out of Schlemm's canal and into the anterior chamber may provide a path for fluid flow between the anterior chamber and Schlemm's canal.

[000101] An assembly may be created by placing a core in a channel defined by the ocular implant. A sheath may be placed around the implant and the core. For example, the core and
15 the implant may then be inserted into the lumen of a sheath. By way of another example, the sheath may be slipped over the implant and the core. The core may be withdrawn from the channel defined by the ocular implant, for example, after the implant has been delivered to a desired location.

[000102] The core may be withdrawn from the channel, for example, by moving the core in a
20 proximal direction relative to the implant. In some applications, this may be accomplished by applying a proximal directed force to the core while holding the implant stationary. The implant may be held stationary, for example, by applying a distally directed reaction force on the implant. In one embodiment, a distally directed reaction force is provided by pushing on a proximal end of the implant with a push tube.

[000103] The core, the implant, and the sheath may be advanced into Schlemm's canal
25 together. Once the implant is in a desired location, the core and the sheath may be withdrawn from the Schlemm's canal leaving the implant in the desired location. In some methods, the core and the sheath are withdrawn from Schlemm's canal simultaneously.

[000104] Figure 16A and Figure 16B are perspective views showing a sheath 120 in
30 accordance with the present detailed description. Figure 16A and Figure 16B may be referred to collectively as Figure 16. Sheath 120 of Figure 16 comprises a proximal portion 150 defining a lumen 122 and a distal portion 152 defining a distal aperture 154. With reference to Figure 16, it will be appreciated that lumen 122 is generally larger than distal aperture 154.

[000105] In the embodiment of Figure 16A, distal portion 152 of sheath 120 comprises a first
35 region 156, a second region 158, and a frangible connection 160 between first region 156 and

second region 158. In Figure 16A, a slit 164 defined by distal portion 152 is shown disposed between first region 156 and second region 158. In the embodiment of Figure 16A, frangible connection 160 comprises a bridge 162 extending across slit 164.

[000106] In the embodiment of Figure 16B, frangible connection 160 has been broken.

5 Frangible connection 160 may be selectively broken, for example, by moving sheath 120 in a proximal direction relative to an implant disposed in lumen 122 having a diameter larger than the diameters of distal opening 154 and distal portion 152 of sheath 120. With reference to Figure 16, it will be appreciated that distal aperture 154 becomes larger when frangible connection 160 is broken.

10 **[000107]** In the embodiment of Figure 16, the presence of slit 164 creates a localized line of weakness in distal portion 152 of sheath 120. This localized line of weakness causes distal portion 152 to selectively tear in the manner shown in Figure 16. It is to be appreciated that distal portion 152 may comprise various elements that create a localized line of weakness without deviating from the spirit and scope of the present detailed description. Examples of
15 possible elements include: a skive cut extending partially through the wall of distal portion 120, a series of holes extending through the wall of distal portion 120, a perf cut, a crease, and a score cut.

[000108] Figure 17 is a perspective view of an assembly including sheath 120 shown in the previous Figure. In the embodiment of Figure 17, an implant 126 is shown extending through
20 distal aperture 154 defined by distal portion 152 of sheath 120. Implant 126 defines a channel 138. In Figure 17, a core 166 can be seen resting in channel 138. Implant 126 and core 166 extend proximally into lumen 122 defined by sheath 120. Distal portion 152 of sheath 120 comprises a first region 156 and a second region 158.

[000109] Figure 18A and Figure 18B are simplified plan views showing a sheath 120 in
25 accordance with the present detailed description. Sheath 120 comprises a distal portion 152 including a first region 156, a second region 158 and a frangible connection between first region 156 and second region 158. In the embodiment of Figure 18A, frangible connection 160 is intact. In the embodiment of Figure 18B, frangible connection 160 is broken. Figure 18A and Figure 18B may be referred to collectively as Figure 18.

30 **[000110]** Sheath 120 of Figure 18 comprises a proximal portion 150 defining a lumen 122. In the embodiment of Figure 18, an implant 126 is disposed in lumen 122. Lumen 122 fluidly communicates with a distal aperture 154 defined by distal portion 152 of sheath 120. Distal portion 152 includes a slit 164 disposed between first region 156 and second region 158. In Figure 18A, a bridge 162 can be seen spanning slit 164. In some useful embodiments, distal
35 portion 152 of sheath 120 has a first hoop strength and proximal portion 150 sheath 120 has a

second hoop strength. The first hoop strength may be limited by the frangible connection in the embodiment of Figure 18A. When this is the case, the second hoop strength is greater than the first hoop strength.

5 [000111] Sheath 120 of Figure 18 comprises a proximal portion 150 defining a lumen 122 and a distal portion 152 defining a distal aperture 154. Lumen 122 has a lumen width LW. Distal aperture has an aperture width AW when frangible connection 160 is intact. With reference to Figure 18B, it will be appreciated that the distal aperture 154 is free to open further when frangible connection 160 is broken.

10 [000112] In some useful embodiments, lumen width LW of lumen 122 is equal to or greater than the width of an implant 126 disposed in lumen 122. In some of these useful embodiments, aperture width AW is smaller than the width of the implant 126. When this is the case, frangible connection 160 can be selectively broken by moving sheath 120 in a proximal direction relative to the implant 126.

15 [000113] Figure 19A, Figure 19B and Figure 19C are multiple plan views of an implant 326 in accordance with the present detailed description. Figure 19A, Figure 19B and Figure 19C may be referred to collectively as Figure 19. Figure 19A may be referred to as a top view of implant 326, Figure 19B may be referred to as a side view of implant 326, and Figure 19C may be referred to as a bottom view of implant 326. The terms top view, side view, and bottom view are used herein as a convenient method for differentiating between the views shown in Figure 19. It
20 will be appreciated that the implant shown in Figure 19 may assume various orientations without deviating from the spirit and scope of this detailed description. Accordingly, the terms top view, side view, and bottom view should not be interpreted to limit the scope of the invention recited in the attached claims.

[000114] Ocular implant 326 of Figure 19 comprises a body 328 that extends along a
25 longitudinal central axis 348. Body 328 of ocular implant 326 has a first major surface 330 and a second major surface 332. In the embodiment of Figure 19, body 328 is curved about longitudinal central axis 348 so that first major surface 330 comprises a concave surface 336 and second major surface 332 comprises a convex surface 334.

30 [000115] A distal portion of body 328 defines a longitudinal channel 338 including a channel opening 339. Channel opening 339 is disposed diametrically opposite a central portion 335 of concave surface 336. In the embodiment of Figure 19, central portion 335 of concave surface 336 defines a plurality of apertures 337. Each aperture 337 fluidly communicates with channel 338.

35 [000116] Figure 20 is a lateral cross-sectional view of ocular implant 326 taken along section line B-B shown in the previous Figure. Ocular implant 326 comprises a body 328 having a first

major surface 330 and a second major surface 332. With reference to Figure 20, it will be appreciated that body 328 curves around a longitudinal central axis 348 so that first major surface 330 comprises a concave surface 336 and second major surface 332 comprises a convex surface 334. The concave surface 336 of body 328 defines a longitudinal channel 338 having a channel opening 339. As shown in Figure 20, body 328 has a circumferential extent that spans an angle W. In the embodiment of Figure 20, angle W has a magnitude that is greater than one hundred eighty degrees.

[000117] Figure 21 is a cross-sectional view showing an implant 326 in accordance with the present detailed description. Ocular implant 326 of Figure 21 comprises a body 328 that extends along a generally curved longitudinal central axis 348. In the embodiment of Figure 21, body 328 has a distal radius of curvature RD and a proximal radius of curvature RP. Each radius of curvature is represented with an arrow in Figure 21. Distal radius of curvature RD is represented by an arrow extending between a first lateral central axis 376 and a distal portion of longitudinal central axis 348. Proximal radius of curvature RP is represented by an arrow extending between a second lateral central axis 378 and a proximal portion of longitudinal central axis 348. In the embodiment of Figure 21, body 328 of ocular implant 326 has an at rest shape that is generally curved. This at rest shape can be established, for example, using a heat-setting process. The rest shape of the implant can be generally aligned with the radius of curvature of Schlemm's canal in a human eye.

[000118] Figure 22A, Figure 22B and Figure 22C are multiple plan views of an implant 526 in accordance with the present detailed description. Figure 22A, Figure 22B and Figure 22C may be referred to collectively as Figure 22. Figure 22A may be referred to as a top view of implant 526, Figure 22B may be referred to as a side view of implant 526, and Figure 22C may be referred to as a bottom view of implant 526. The terms top view, side view, and bottom view are used herein as a convenient method for differentiating between the views shown in Figure 22. It will be appreciated that the implant shown in Figure 22 may assume various orientations without deviating from the spirit and scope of this detailed description.

[000119] Accordingly, the terms top view, side view, and bottom view should not be interpreted to limit the scope of the invention recited in the attached claims.

[000120] Ocular implant 526 of Figure 22 comprises a body 528 that extends along a longitudinal central axis 548. Body 528 of ocular implant 526 has a first major surface 530 and a second major surface 532. In the embodiment of Figure 22, body 528 is curved about longitudinal central axis 548 so that first major surface 530 comprises a concave surface 536 and second major surface 532 comprises a convex surface 534.

[000121] A distal portion of body 528 defines a longitudinal channel 538 including a channel opening 539. Channel opening 539 is disposed diametrically opposite a central portion 535 of concave surface 536. In the embodiment of Figure 22, central portion 535 of concave surface 536 defines a plurality of apertures 537. Each aperture 537 fluidly communicates with channel 538.

[000122] Figure 23 is a lateral cross-sectional view of ocular implant 526 taken along section line C-C shown in the previous Figure. Ocular implant 526 comprises a body having a first major side 530 and a second major side 532. With reference to Figure 23, it will be appreciated that body 528 curves around a longitudinal central axis 548 so that first major side 530 comprises a concave surface 536 and second major side 532 comprises a convex surface 534. The concave surface 536 of body 528 defines a longitudinal channel 538 having a channel opening 539. As shown in Figure 23, body 528 has a circumferential extent that spans an angle C. In the embodiment of Figure 23, angle C has a magnitude that is about one hundred eighty degrees. Some useful implants in accordance with the present detailed description comprise a body having a circumferential extend that spans an angle that is about one hundred eighty degrees. Some particularly useful implants in accordance with the present detailed description comprise a body having a circumferential extend that spans an angle that is equal to or less than one hundred eighty degrees.

[000123] Figure 24 is a plan view showing an implant 526 in accordance with the present detailed description. Ocular implant 526 of Figure 24 comprises a body 528 that extends along a generally curved longitudinal central axis 548. In the embodiment of Figure 24, body 528 has a distal radius of curvature RD and a proximal radius of curvature RP. Each radius of curvature is represented with an arrow in Figure 24. Distal radius of curvature RD is represented by an arrow extending between a first lateral central axis 576 and a distal portion of longitudinal central axis 548. Proximal radius of curvature RP is represented by an arrow extending between a second lateral central axis 578 and a proximal portion of longitudinal central axis 548. In the embodiment of Figure 24, body 528 of ocular implant 526 has an at rest shape that is generally curved. This at rest shape can be established, for example, using a heat-setting process.

[000124] Figure 25A through Figure 25D are a series of plan views illustrating a method in accordance with the present detailed description. Figure 25A is a plan view showing an implant 426. Implant 426 comprises a body 428 defining a plurality of openings 440. Openings 440 include a first opening 442 and a second opening 444.

[000125] Figure 25B is a plan view showing an assembly 408 including implant 426. Assembly 408 of Figure 25B may be created by placing a core 406 in a channel 438 defined by implant 426. A sheath 420 may be placed around implant 426 and core 406. For example, core

406 and implant 426 may be inserted into a lumen defined by sheath 420. By way of another example, sheath 420 may be slipped over implant 426 and core 406.

[000126] Figure 25C is a plan view showing assembly 408 disposed in Schlemm's canal SC. The wall W of Schlemm's canal SC comprises a plurality of cells 90. With reference to Figure 5 25C, it will be appreciated that sheath 420 is disposed between implant 426 and cells 90. A method in accordance with the present detailed description may include the step of advancing a distal end of a cannula through a cornea of the eye so that a distal portion of the cannula is disposed in the anterior chamber of the eye. The cannula may be used to access Schlemm's canal, for example, by piercing the wall of Schlemm's canal with a distal portion of the cannula. 10 A distal portion of sheath 420 may be advanced out of a distal port of the cannula and into Schlemm's canal SC. Ocular implant 426 may be disposed inside sheath 420 while the distal portion of sheath 420 is advanced into Schlemm's canal SC.

[000127] In the embodiment of Figure 25C, ocular implant 426 comprises a body defining a plurality of openings 440. With reference to Figure 25C, it will be appreciated that openings 440 15 are covered by sheath 420 and that a distal portion of implant 426 may be advanced into Schlemm's canal while openings 440 are covered by sheath 420. Covering openings 440 as implant 426 is advanced into Schlemm's canal SC may reduce the trauma inflicted on cells 90 by the procedure.

[000128] In some useful embodiments, sheath 420 comprises a coating disposed on an outer 20 surface thereof. The properties of the coating may be selected to further reduce the trauma inflicted on cells 90 by the procedure. The coating may comprise, for example, a hydrophilic material. The coating may also comprise, for example, a lubricious polymer. Examples of hydrophilic materials that may be suitable in some applications include: polyalkylene glycols, alkoxy polyalkylene glycols, copolymers of methylvinyl ether and maleic acid 25 poly(vinylpyrrolidone), poly(N-alkylacrylamide), poly(acrylic acid), poly(vinyl alcohol), poly(ethyleneimine), methyl cellulose, carboxymethyl cellulose, polyvinyl sulfonic acid, heparin, dextran, modified dextran and chondroitin sulphate.

[000129] In Figure 25C, the distal portion of sheath 420 is shown extending between a smaller, distal diameter and a larger, proximal diameter. In the embodiment of Figure 25C, the distal 30 portion of sheath 420 has a generally tapered shape. The tapered transition of the distal portion of sheath 420 may create a non traumatic transition that dilates Schlemm's canal SC as sheath 420 is advanced into Schlemm's canal SC. This arrangement may reduce the likelihood that skiving of wall W occurs as sheath 420 is advanced into Schlemm's canal SC.

[000130] Figure 25D is a plan view showing implant 426 disposed in Schlemm's canal SC. In 35 the embodiment of Figure 25D, openings 440 defined by body 428 have been uncovered.

Openings 440 may be uncovered, for example, by moving sheath 420 in a proximal direction relative to implant 426. In some applications, this may be accomplished by applying a proximal directed force to sheath 420 while holding implant 426 stationary. Implant 426 may be held stationary, for example, by applying a distally directed reaction force on implant 426. In the embodiment of Figure 25, a distally directed reaction force may be provided by pushing on a proximal end of implant 426 with a push tube.

[000131] In the embodiment of Figure 25D, core 406 has been removed channel 438 defined by implant 426. Core 406 may be withdrawn from channel 438, for example, by moving core 406 in a proximal direction relative to implant 426. In some applications, this may be accomplished by applying a proximal directed force to core 406 while holding implant 426 stationary. Implant 426 may be held stationary, for example, by applying a distally directed reaction force on implant 426.

[000132] Figure 26A through Figure 26D are a series of section views illustrating a method in accordance with the present detailed description. The picture plane of Figure 26A extends laterally across Schlemm's canal SC and the trabecular meshwork 596 overlaying Schlemm's canal SC. In the embodiment of Figure 26A, the distal end of a cannula 502 has been positioned proximate Schlemm's canal SC. A method in accordance with the present detailed description may include the step of advancing the distal end of cannula 502 through the cornea of an eye so that a distal portion of cannula 502 is disposed in the anterior chamber 594 of the eye.

[000133] Figure 26B is an additional section view showing Schlemm's canal SC shown in the previous Figure. In Figure 26, a distal portion of cannula 502 is shown extending through a wall W of Schlemm's canal SC and trabecular meshwork 596. A distal port 504 of cannula 502 fluidly communicates with Schlemm's canal in the embodiment of Figure 26B.

[000134] Figure 26C is an additional section view showing Schlemm's canal SC shown in the previous Figure. In the embodiment of Figure 26C, a distal portion of a sheath 520 is shown extending through distal port 504 of cannula 502 and into Schlemm's canal SC. Methods in accordance with the present invention can be used to deliver an implant 526 into Schlemm's canal SC. In these methods, a distal portion of sheath 520 and a core 506 may be advanced out of distal port 504 of cannula 502 and into Schlemm's canal SC. Ocular implant 526 may be disposed inside sheath 520 while the distal portion of sheath 520 is advanced into Schlemm's canal SC.

[000135] Figure 26D is an additional section view showing implant 526 shown in the previous Figure. In the embodiment of Figure 26, sheath 520, core 506, and cannula 502 have all been withdrawn from the eye. Implant 526 is shown resting in Schlemm's canal SC in Figure 26.

[000136] Figure 26 is section view illustrating an additional embodiment in accordance with the present detailed description. The picture plane of Figure 26 extends laterally across Schlemm's canal SC and the trabecular meshwork 596 overlaying Schlemm's canal SC. In the embodiment of Figure 26, an implant 626 is disposed in Schlemm's canal.

5 [000137] Figure 27A and Figure 27B are simplified plan views showing a sheath 720 in accordance with the present detailed description. Figure 27A and Figure 27B may be referred to collectively as Figure 27. Sheath 720 of Figure 27 comprises a proximal portion 750 defining a lumen 722 and a distal portion 752 defining a distal aperture 754. With reference to Figure 27, it will be appreciated that lumen 722 is generally larger than distal aperture 754.

10 [000138] In the embodiment of Figure 27A, distal portion 752 of sheath 720 comprises a first region 756, a second region 758, and a frangible connection 760 between first region 756 and second region 758. In Figure 27A, a first slit 764 defined by distal portion 752 is shown disposed between first region 756 and second region 758. In the embodiment of Figure 27A, frangible connection 760 comprises a bridge 762 extending across first slit 764. With reference
15 to Figure 27A, it will be appreciated that distal portion 752 defines a number of slits in addition to first slit 764.

[000139] In the embodiment of Figure 27B, frangible connection 760 has been broken. Frangible connection 760 may be selectively broken, for example, by moving sheath 720 in a proximal direction relative to an implant disposed in lumen 722 having a diameter larger than the
20 diameters of distal opening 754 and distal portion 752 of sheath 720. With reference to Figure 27, it will be appreciated that distal aperture 754 becomes larger when frangible connection 760 is broken.

[000140] In the embodiment of Figure 27, the presence of slit 764 creates a localized line of weakness in distal portion 752 of sheath 720. This localized line of weakness causes distal
25 portion 752 to selectively tear in the manner shown in Figure 27. It is to be appreciated that distal portion 752 may comprise various elements that create a localized line of weakness without deviating from the spirit and scope of the present detailed description. Examples of possible elements include: a skive cut extending partially through the wall of distal portion 720, a series of holes extending through the wall of distal portion 720, a perf cut, a crease, and a
30 score cut.

[000141] In Figure 27, distal portion 752 of sheath 720 is shown extending between distal opening 754 and lumen 722. In the embodiment of Figure 27, distal portion 752 of sheath 720 has a blunt shape. The blunt shape of distal portion 752 of sheath 720 may create a non traumatic transition that dilates Schlemm's canal as sheath 720 is advanced into Schlemm's canal.

This arrangement may reduce the likelihood that skiving of the canal wall occurs as sheath 720 is advanced into Schlemm's canal.

[000142] While embodiments of the present invention have been shown and described, modifications may be made, and it is therefore intended in the appended claims to cover all such
5 changes and modifications which fall within the true spirit and scope of the invention.

CLAIMS

WHAT IS CLAIMED IS:

1. An ocular implant adapted to reside at least partially in a portion of Schlemm's canal of
5 an eye, the eye having an iris defining a pupil, the implant comprising:
a body having a first major surface and a second major surface;
the body being curved about a longitudinal central axis so that the first major surface
comprises a concave surface and the second major surface comprises a convex surface;
a distal portion of the body defining a longitudinal channel including a channel opening,
10 the channel opening being disposed diametrically opposite a central portion of the concave
surface; and
the body being adapted and configured such that the ocular implant assumes an
orientation in which the channel opening is adjacent a major side of Schlemm's canal when the
ocular implant is disposed in Schlemm's canal.
15
2. The ocular implant of claim 1 wherein the channel opens away from the pupil when the
channel opening is adjacent an outer major side of Schlemm's canal, the outer major side being
further from the pupil than an inner major side of Schlemm's canal.
- 20 3. The ocular implant of claim 1 wherein:
the channel has a width and a depth; and
an aspect ratio of the width to the depth is such that the ocular implant assumes an
orientation in which the channel opening is adjacent a major side of Schlemm's canal when the
ocular implant is disposed in Schlemm's canal.
25
4. The ocular implant of claim 3 wherein the aspect ratio of the width to the depth is greater
than one.
5. The ocular implant of claim 4 wherein the aspect ratio of the width to the depth is about
30 two.
6. The ocular implant of claim 1 wherein:
the body has a first lateral extent, a second lateral extent, and a longitudinal length; and

an aspect ratio of the first lateral extent to the second lateral extent is such that the ocular implant assumes an orientation in which the channel opening is adjacent a major side of Schlemm's canal when the ocular implant is disposed in Schlemm's canal.

- 5 7. The ocular implant of claim 6 wherein the aspect ratio of the first lateral extent to the second lateral extent is greater than one.
8. The ocular implant of claim 7 wherein the aspect ratio of the first lateral extent to the second lateral extent is about two.
- 10 9. The ocular implant of claim 1 wherein the distal portion of the body extends across an angular span of less than 180 degrees as the body curves about the longitudinal central axis.
10. The ocular implant of claim 1, wherein the body defines additional openings fluidly
15 communicating with the channel and the body of the implant is more than 50% open due to the openings defined by the body.
11. The ocular implant of claim 1, wherein the body has a diameter of between about 0.005 inches and about 0.04 inches.
- 20 12. The ocular implant of claim 1 further comprising a therapeutic agent deposited on the body.
13. The ocular implant of claim 12 wherein the a therapeutic agent comprises an anti-
25 glaucoma drug.
14. The ocular implant of claim 13 wherein the anti-glaucoma drug comprises a prostaglandin analog.
- 30 15. The ocular implant of claim 14 wherein the prostaglandin analog comprises latanprost.
16. The ocular implant of claim 1, wherein the body has a thickness extending between the concave surface and the convex surface.

17. The ocular implant of claim 16, wherein the thickness of the body is substantially uniform along a length of the body.

18. The ocular implant of claim 16, wherein the thickness of the body is substantially
5 uniform along a circumference of the body.

19. The ocular implant of claim 1, wherein the body is curved about a lateral central axis so that a longitudinal axis of the body defines a plane.

10 20. The ocular implant of claim 19, wherein the body has a lateral radius of curvature extending between the lateral central axis and an outer extent of the body.

21. The ocular implant of claim 20, wherein the lateral radius of curvature is substantially constant.

15 22. The ocular implant of claim 21, wherein the lateral radius of curvature varies along a length of the body.

23. An ocular implant system for treating an eye having a cornea defining an anterior
20 chamber, an iris disposed in the anterior chamber and a Schlemm's canal generally encircling the iris, the ocular implant system comprising:

a delivery cannula comprising a tubular member defining a distal opening, a proximal opening, and a passageway extending between the proximal opening and the distal opening;

25 the delivery cannula including a curved portion disposed between the distal opening and the proximal opening, the delivery cannula being adapted and configured such that the distal opening can be placed in fluid communication with Schlemm's canal when the cannula is extending through the cornea of the eye and the curved portion of the cannula is at least partially disposed in the anterior chamber of the eye;

30 the implant system including an ocular implant disposed in the passageway defined by the delivery cannula, the ocular implant comprising a body having a first major surface and a second major surface, the body being curved about a longitudinal central axis so that the first major surface comprises a concave surface and the second major surface comprises a convex surface, a distal portion of the body defining a longitudinal channel including a channel opening; and

the ocular implant being oriented relative to the delivery cannula such that the channel of the ocular implant opens in a radially outward direction when the ocular implant passes through the curved portion of the delivery cannula.

5 24. An ocular implant system for treating an eye having a cornea defining an anterior chamber, an iris disposed in the anterior chamber, and a Schlemm's canal generally encircling the iris, the ocular implant system comprising:

10 an ocular implant comprising a body having a first major surface and a second major surface, the body being curved about a longitudinal central axis so that the first major surface comprises a concave surface and the second major surface comprises a convex surface, a distal portion of the body defining a longitudinal channel including a channel opening, the body defining additional openings fluidly communicating with the channel; and

15 a sheath disposed about the body of the ocular implant, the sheath covering at least some of the openings, and the sheath being adapted and configured such that the sheath can be selectively removed from the body for uncovering the openings.

25. The ocular implant system of claim 24 further comprising:

a delivery cannula comprising a tubular member defining a distal opening, a proximal opening, and a passageway extending between the proximal opening and the distal opening;

20 the delivery cannula including a curved portion disposed between the distal opening and the proximal opening, and the delivery cannula being adapted and configured such that the distal opening can be placed in fluid communication with Schlemm's canal when the cannula is extending through the cornea of the eye and the curved portion of the cannula is at least partially disposed in the anterior chamber of the eye; and

25 wherein the ocular implant is disposed in the passageway defined by the cannula, the ocular implant being oriented relative to the delivery cannula such that the channel of the ocular implant opens in a radially outward direction when the ocular implant passes through the curved portion of the delivery cannula.

30 26. The system of claim 24 wherein the body of the ocular implant extends across an angular span of less than 180 degrees as the body curves about the longitudinal central axis.

27. The system of claim 24, wherein the body of the implant is more than 50% open due to the openings defined by the body.

35

28. The system of claim 24, wherein the body has a diameter of between about 0.005 inches and about 0.04 inches.
29. The system of claim 24 wherein:
5 the sheath comprises a proximal portion defining a lumen and a distal portion defining a distal aperture;
the lumen has a lumen width; and
the distal aperture has a aperture width.
- 10 30. The system of claim 29 wherein the aperture width is smaller than the lumen width.
31. The system of claim 29 wherein the distal portion provides a transition from the lumen width to the aperture width.
- 15 32. The system of claim 29 wherein:
the lumen width is equal to or greater than a width of the implant; and
the aperture width is smaller than the width of the implant.
33. The system of claim 24 wherein the distal portion comprises a first region, a second
20 region, and a slit disposed between the first region and the second region.
34. The system of claim 24 further comprising a frangible connection between the first region and the second region.
- 25 35. The system of claim 24 wherein the frangible connection comprises a bridge extending across the slit.
36. The system of claim 24 wherein the distal portion comprises a first region, a second
30 region, and a frangible connection between the first region and the second region.
37. The system of claim 24 wherein the aperture width of the distal aperture becomes larger when the frangible connection is broken.
38. The system of claim 24 wherein:
35 the distal portion of the sheath has a first hoop strength;

the proximal portion of the sheath has a second hoop strength; and
the second hoop strength is greater than the first hoop strength.

39. The system of claim 24 wherein the hoop strength of the distal portion is limited by the
5 frangible connection.
40. The system of claim 24 wherein the distal portion of the sheath extends beyond a distal
end of the implant.
- 10 41. The system of claim 24 wherein the frangible connection breaks when the sheath is
moved in a proximal direction relative to the implant.
42. The system of claim 24 wherein the distal portion of the sheath has a tapered shape.
- 15 43. The system of claim 24 wherein the distal portion of the sheath has a blunt shape.
44. The system of claim 24 further comprising a core resting in the longitudinal channel of
the implant.
- 20 45. The system of claim 24 further comprising a push tube contacting a proximal end of the
implant.
46. The system of claim 24 further comprising a cannula.
- 25 47. The system of claim 24 wherein the core, the push tube, and the sheath extend into a
lumen defined by the cannula.
48. The system of claim 24 wherein the implant is disposed in a lumen defined by the
cannula.
- 30 49. A method for inserting an ocular implant into Schlemm's canal of a patient's eye, the
method comprising:
providing an ocular implant comprising a body having a first major surface and a second
major surface, the body being curved about a longitudinal central axis so that the first major
35 surface comprises a concave surface and the second major surface comprises a convex surface, a

distal portion of the body defining a longitudinal channel including a channel opening, the body defining additional openings fluidly communicating with the channel;

covering at least some of the openings;

5 advancing at least a distal portion of the implant into Schlemm's canal while at least some of the openings are covered; and

uncovering at least some of the openings while the distal portion of the implant is disposed in Schlemm's canal.

10 50. The method of claim 49 further comprising orienting the ocular implant so that the channel opening is adjacent an outer major side of Schlemm's canal.

51. The method of claim 49, further comprising:

advancing a distal end of a cannula through a cornea of the eye; and

inserting a distal portion of the cannula into an anterior chamber of the eye.

15

52. The method of claim 49, wherein covering at least some of the apertures comprises positioning a sheath over at least a portion of the implant.

20 53. The method of claim 49, wherein uncovering at least some of the apertures comprises moving the sheath in a proximal direction relative to the implant.

54. The method of claim 53, wherein uncovering at least some of the apertures comprises breaking a frangible portion of the sheath.

25 55. The method of claim 54, wherein the frangible portion of the sheath breaks when the sheath is moved in a proximal direction relative to the implant.

56. The method of claim 55, wherein moving the sheath in a proximal direction relative to the implant causes the frangible portion of the sheath to break.

30

57. The method of claim 56, wherein moving the sheath in a proximal direction relative to the implant comprises applying a proximal directed force to the sheath while applying a distally directed reaction force on the implant.

58. The method of claim 57, wherein applying a distally directed reaction force on the implant comprises pushing on a proximal end of the implant with a push tube.

59. The method of claim 58, wherein moving the sheath in a proximal direction relative to the implant comprises applying a proximal directed force to the sheath while holding the implant stationary.

60. The method of claim 59, wherein holding the implant stationary comprises contacting a proximal end of the implant with a distal end of a push tube, and holding the push tube stationary.

61. The method of claim 49, wherein advancing at least a distal portion of the implant into Schlemm's canal comprises advancing only a distal portion of the implant into Schlemm's canal.

62. The method of claim 49, further comprising advancing a distal portion of a core into Schlemm's canal.

63. The method of claim 62, further comprising advancing a distal portion of a sheath into Schlemm's canal.

64. The method of claim 63, further comprising withdrawing the core from the Schlemm's canal.

65. The method of claim 64, further comprising withdrawing the sheath from Schlemm's canal.

66. The method of claim 65, wherein the core and the sheath are withdrawn from Schlemm's canal simultaneously.

67. The method of claim 49, further comprising placing a core in a channel defined by the ocular implant.

68. The method of claim 67, further comprising withdrawing the core from the channel defined by the ocular implant.

69. The method of claim 68, wherein withdrawing the core from the ocular implant comprises applying a proximally directed force on the core while applying a distally directed reaction force on the implant.

5 70. The method of claim 69, wherein applying a distally directed reaction force on the implant comprises pushing on a proximal end of the implant with a push tube.

71. The method of claim 70, wherein withdrawing the core from the channel defined by the ocular implant comprises applying a proximally directed force on the core while holding the
10 implant stationary.

72. The method of claim 71, wherein holding the implant stationary comprises contacting a proximal end of the implant with a distal end of a push tube, and holding the push tube
stationary.

15 73. The method of claim 49, further comprising ceasing advancement of the sheath into Schlemm's canal when a proximal portion of the implant remains in an anterior chamber of the eye and a distal portion of the implant lies in Schlemm's canal.

20

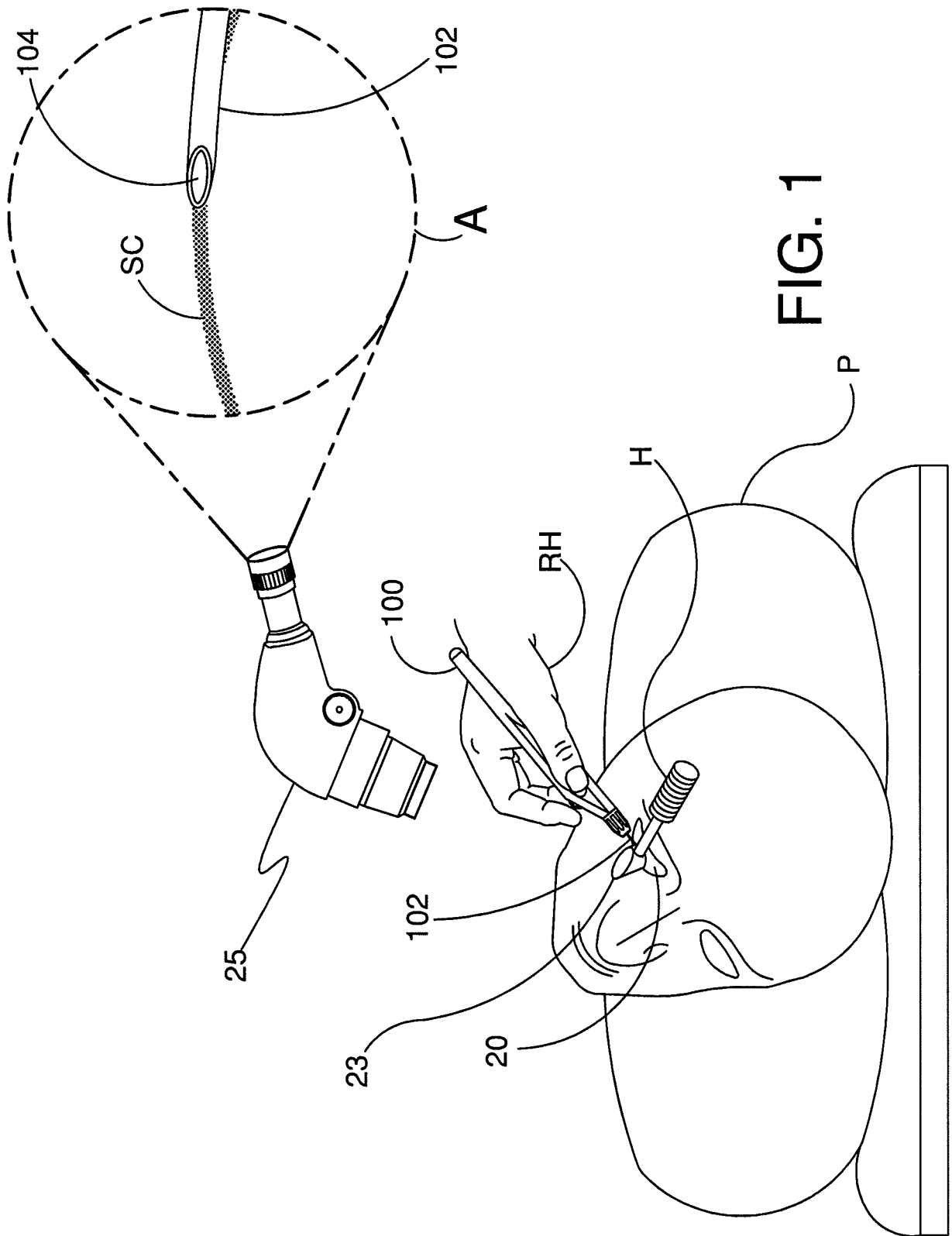

FIG. 1

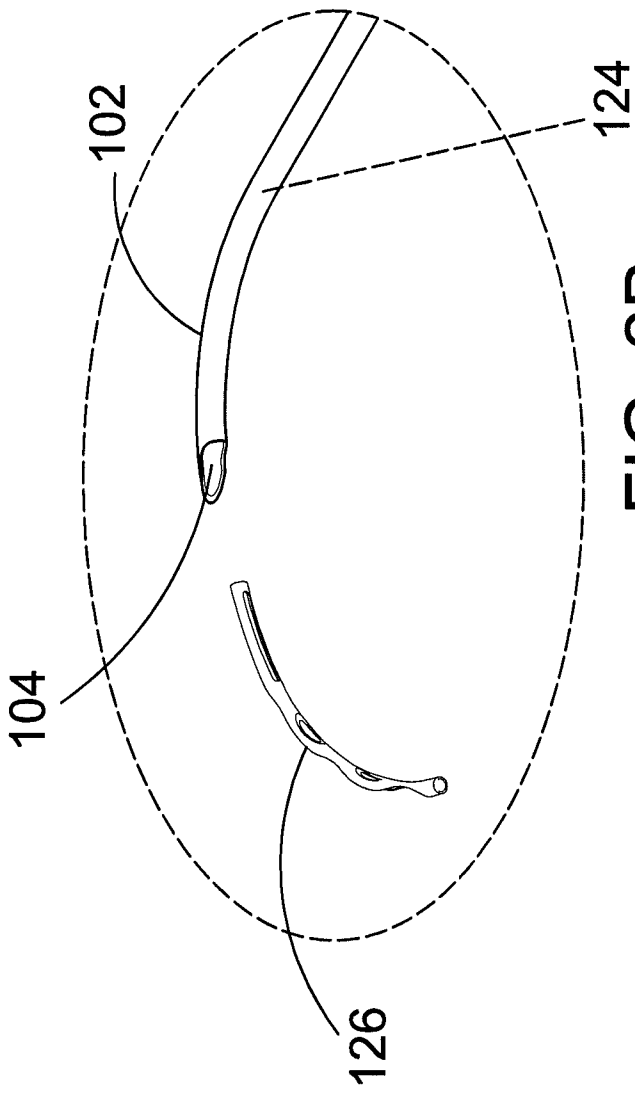

FIG. 2B

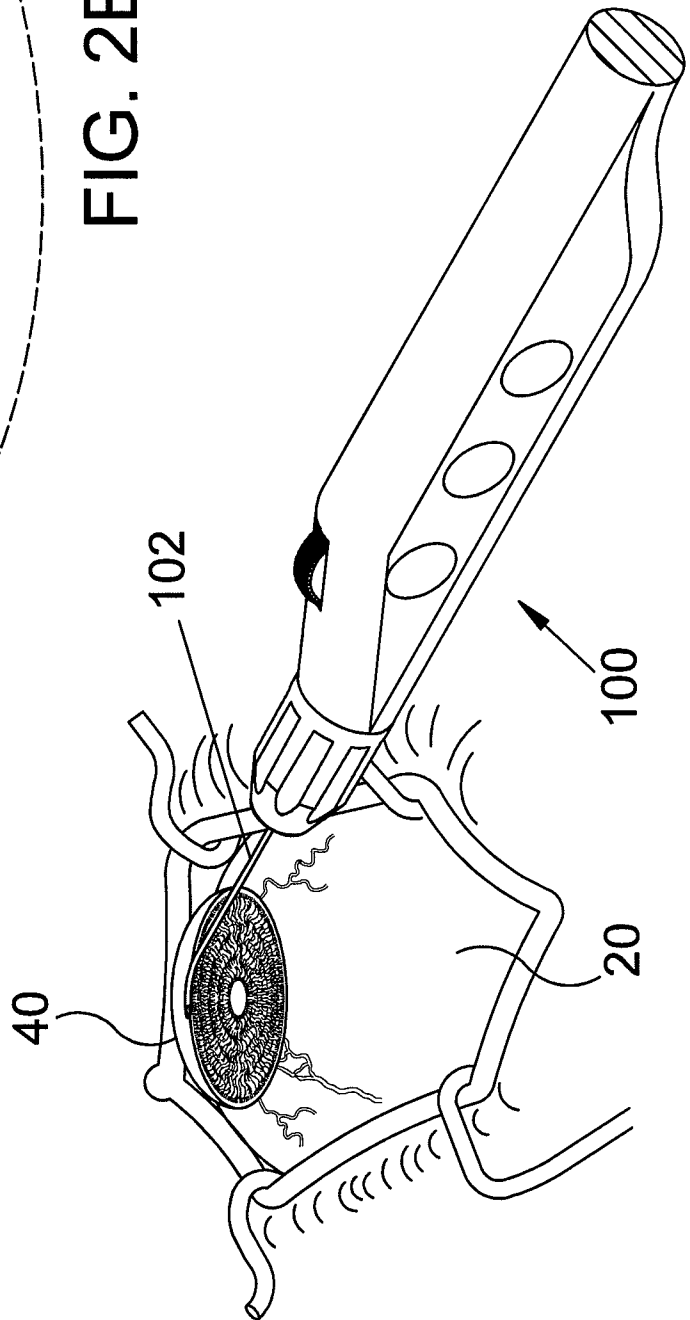

FIG. 2A

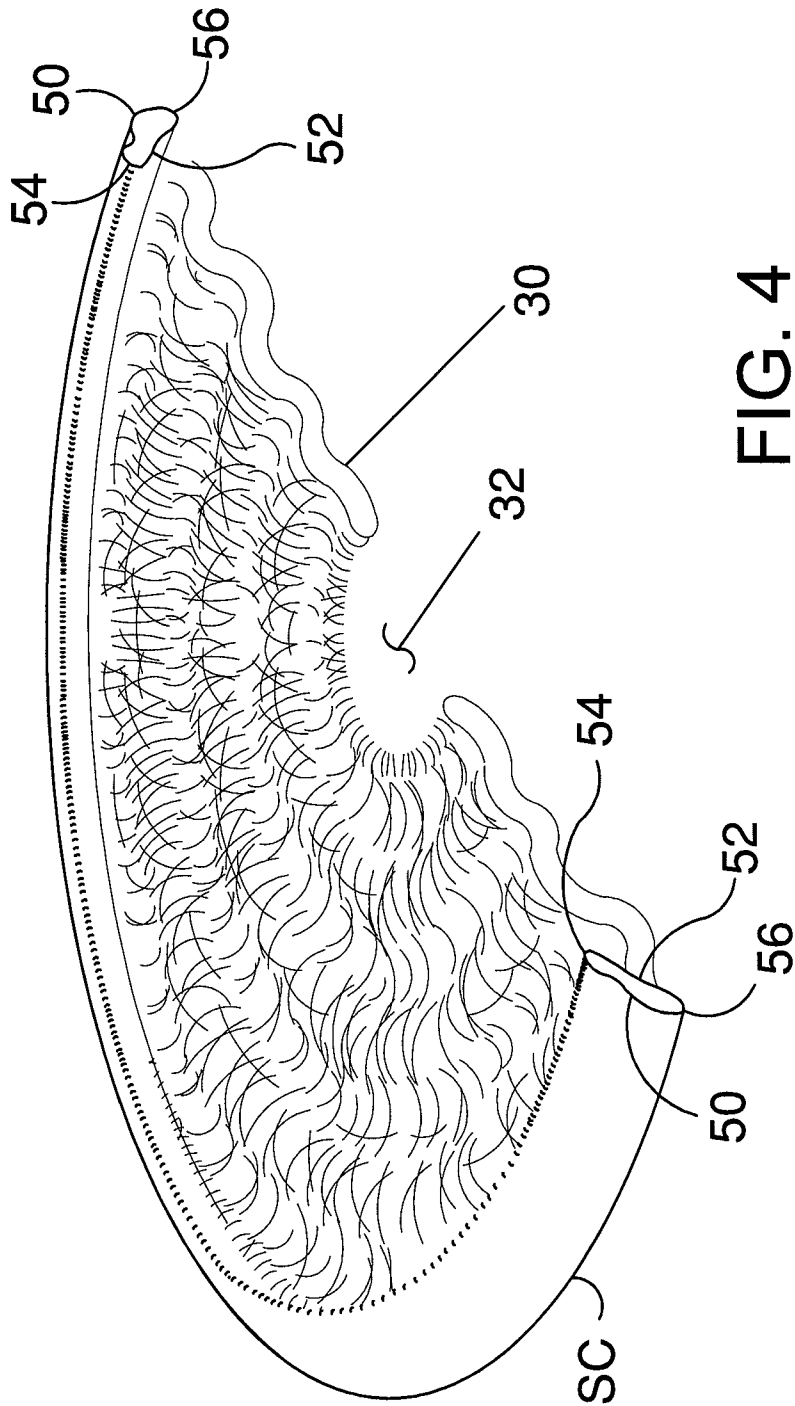

FIG. 4

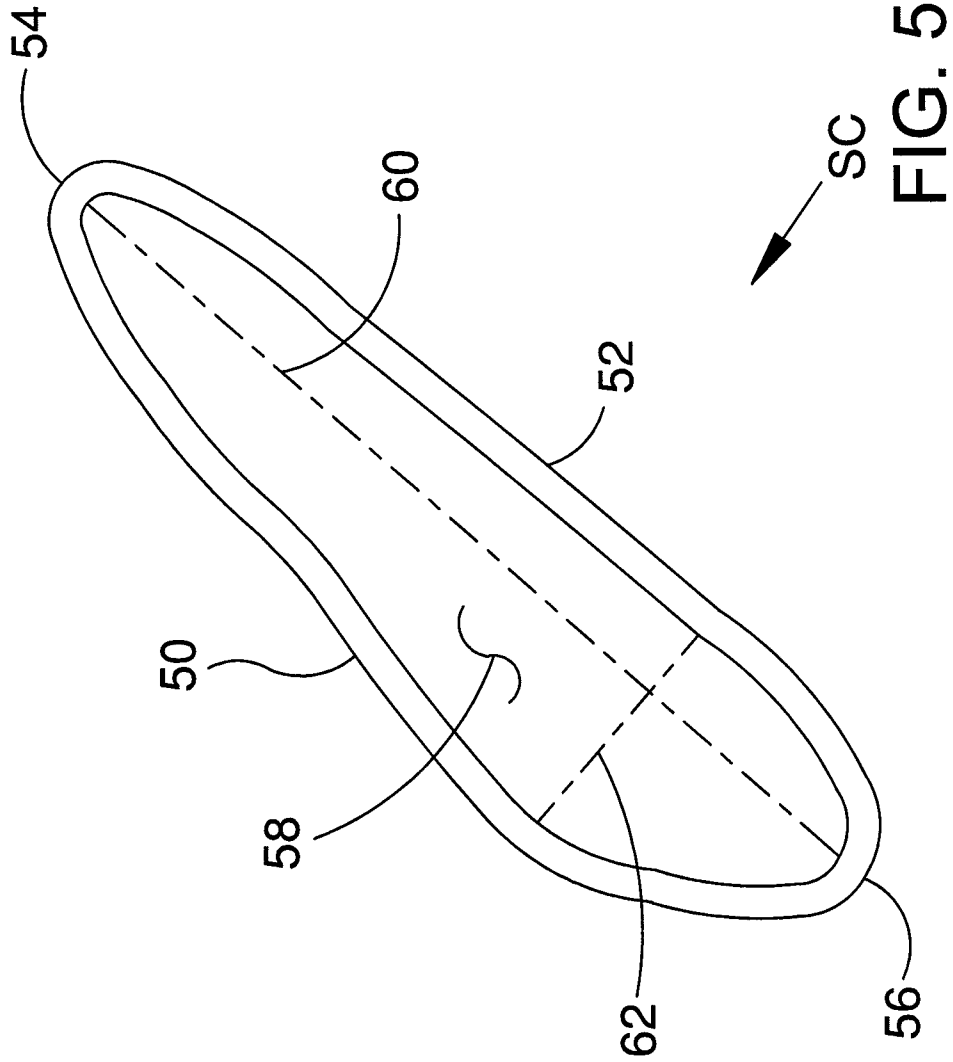

FIG. 5

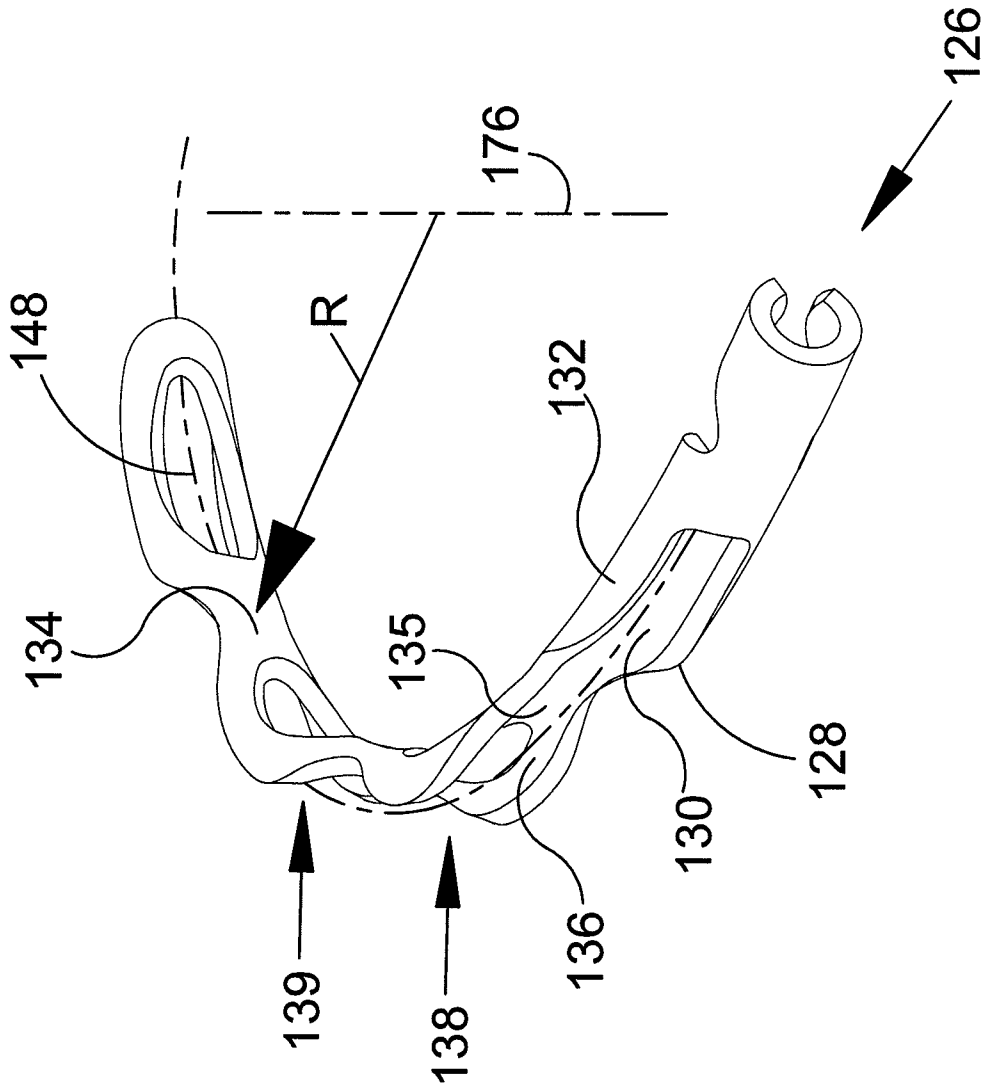

FIG. 6

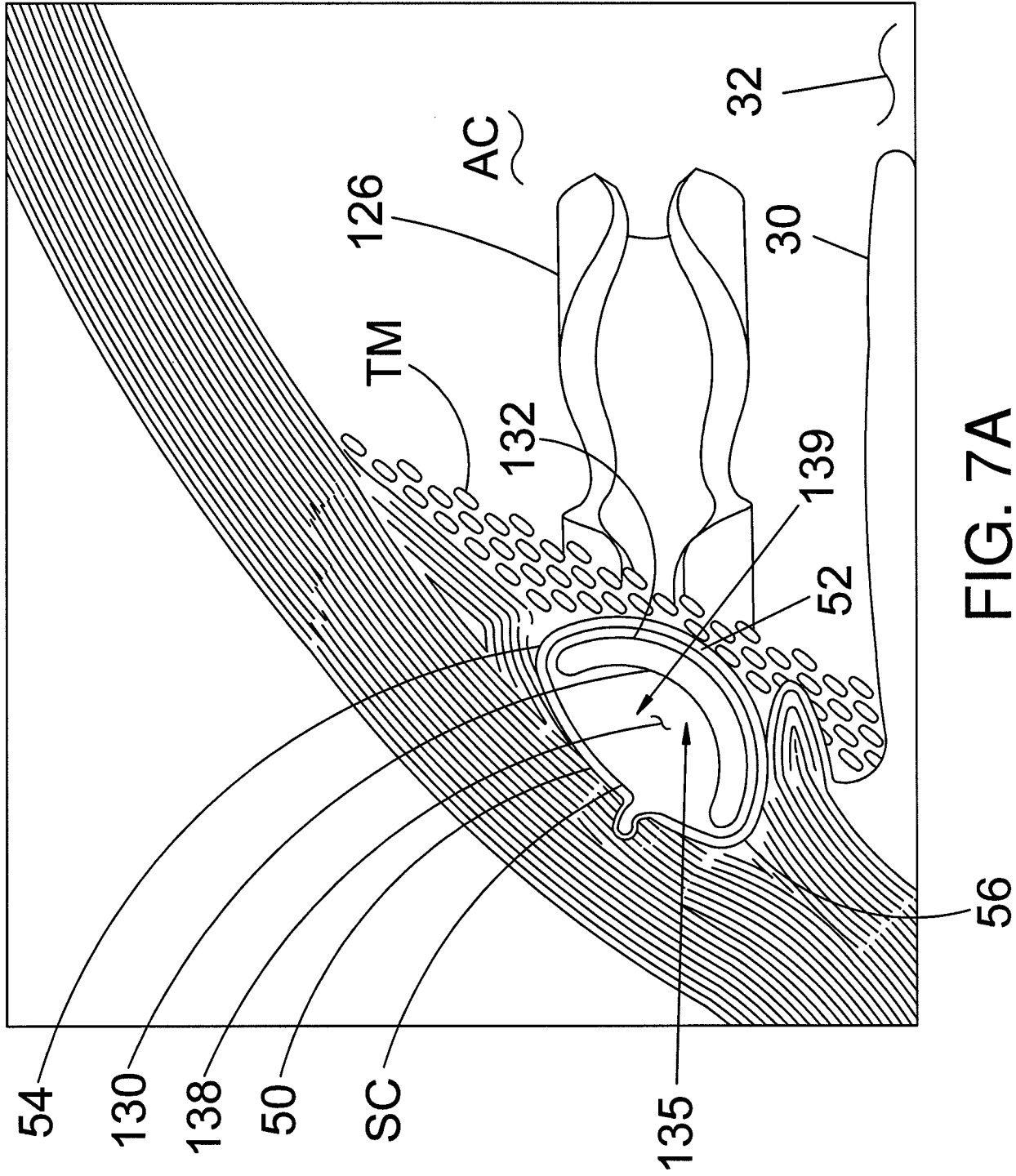

FIG. 7A

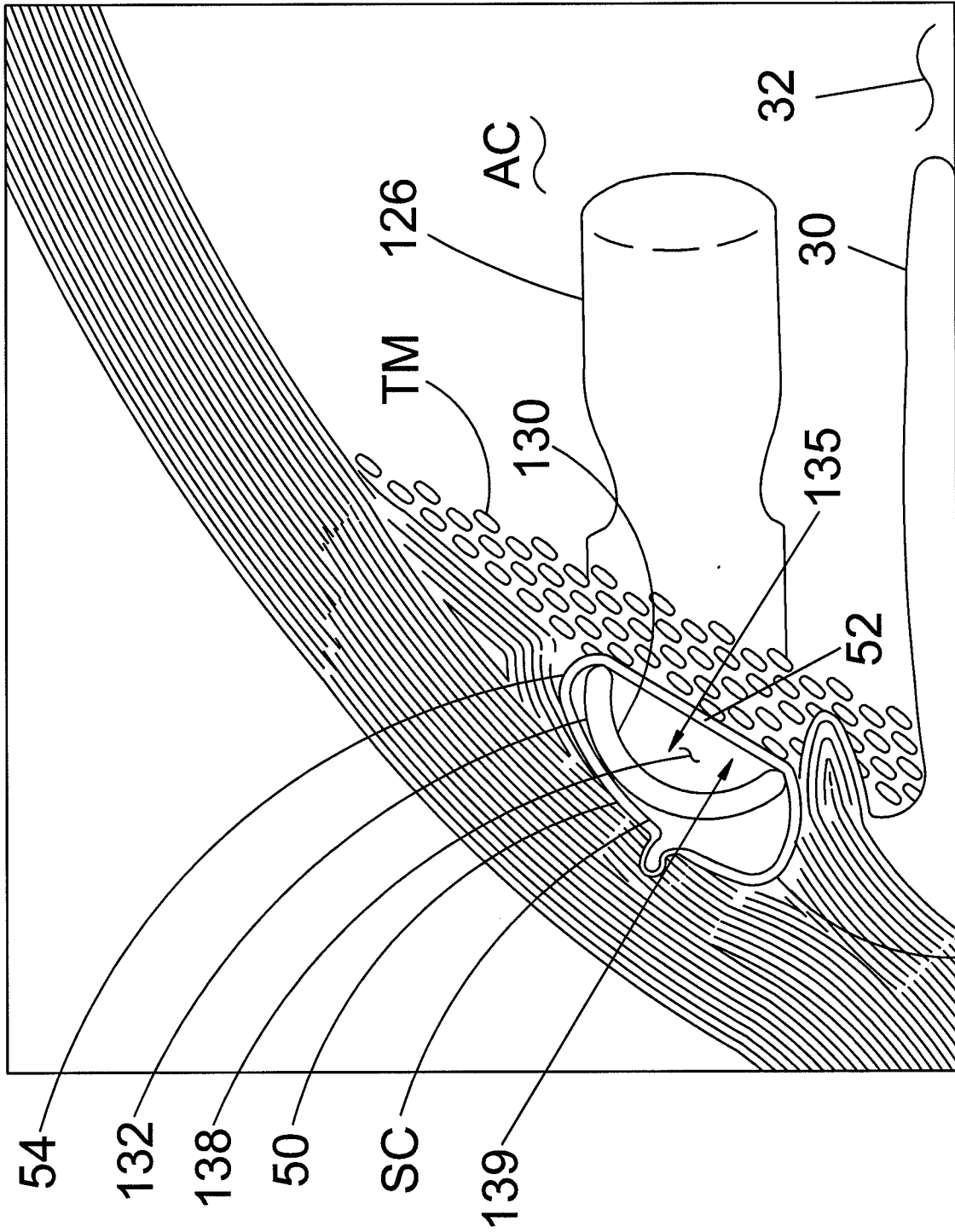
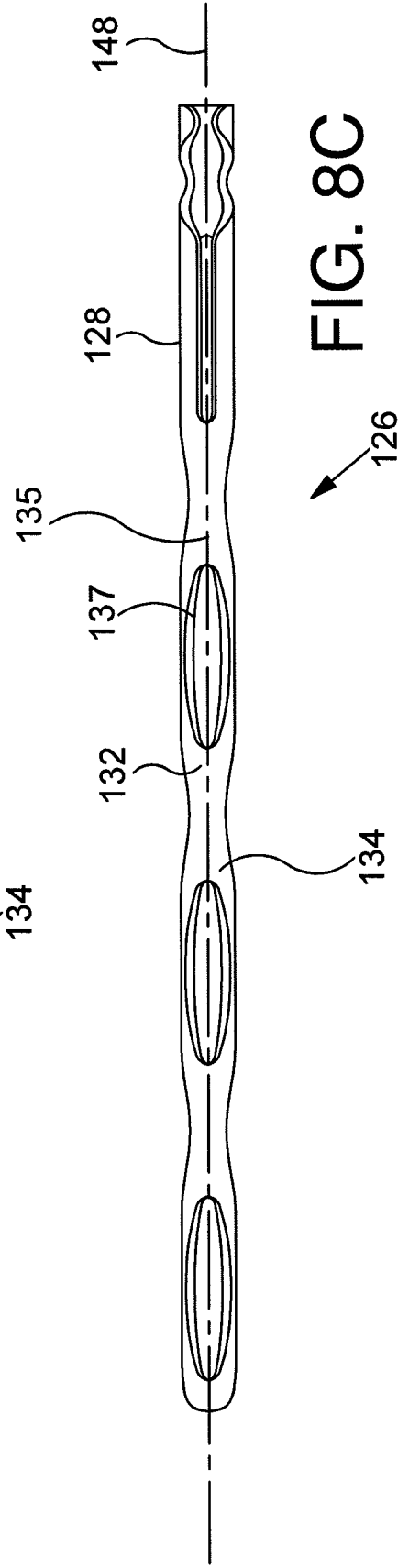
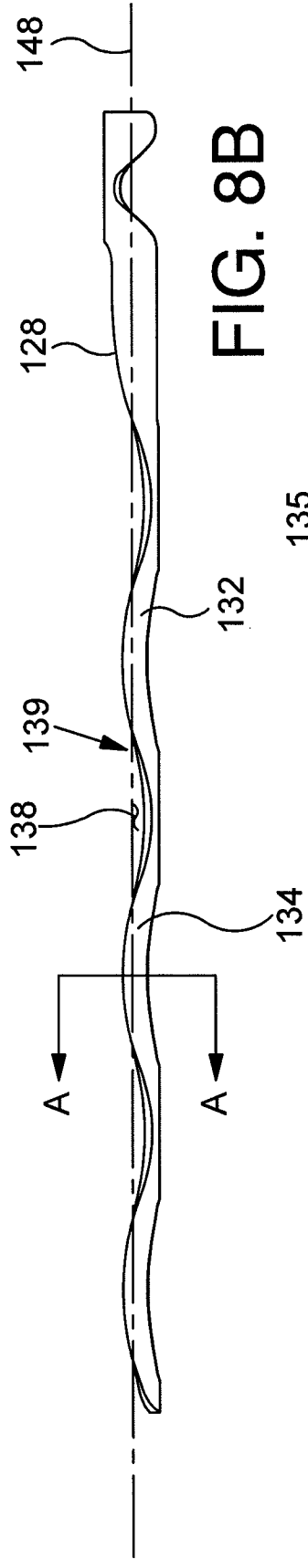
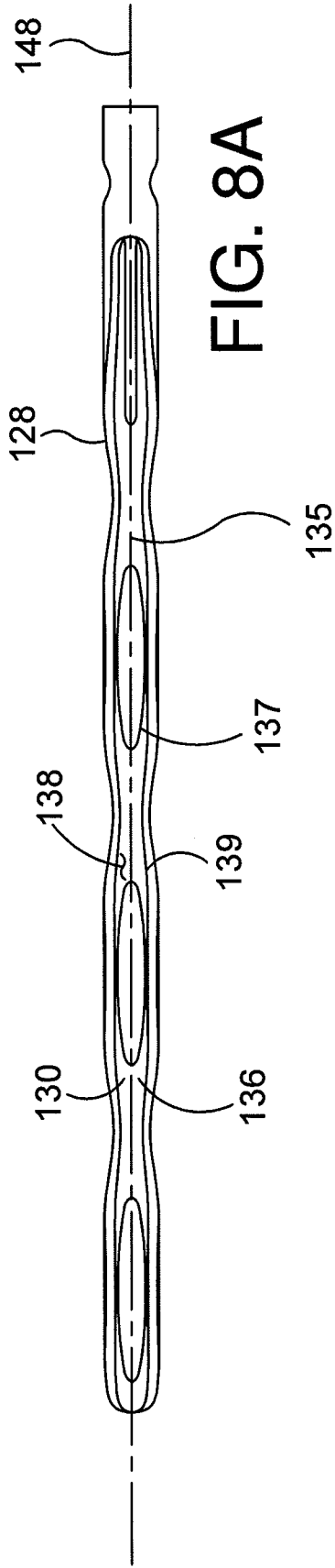

FIG. 7B



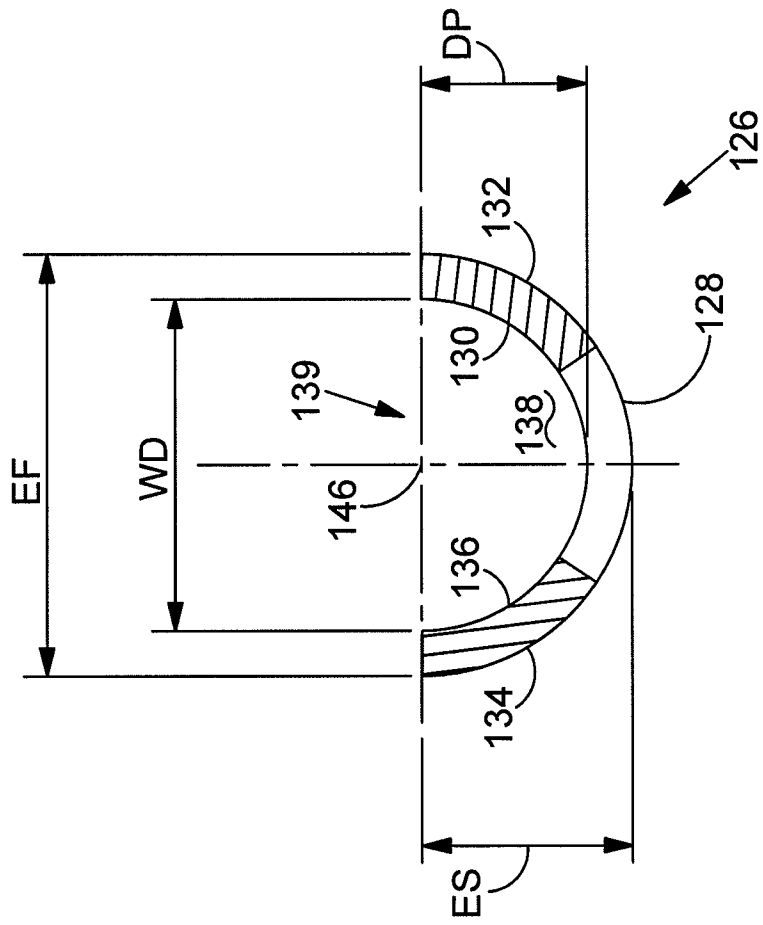
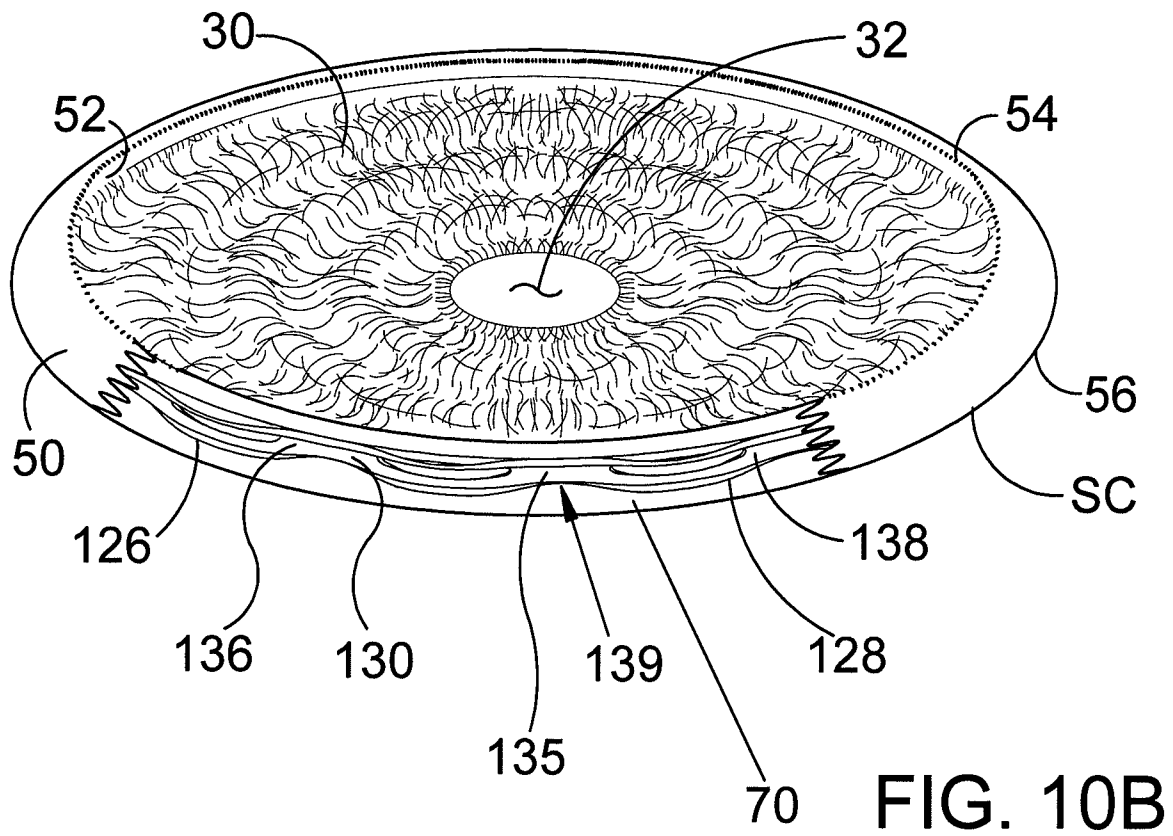
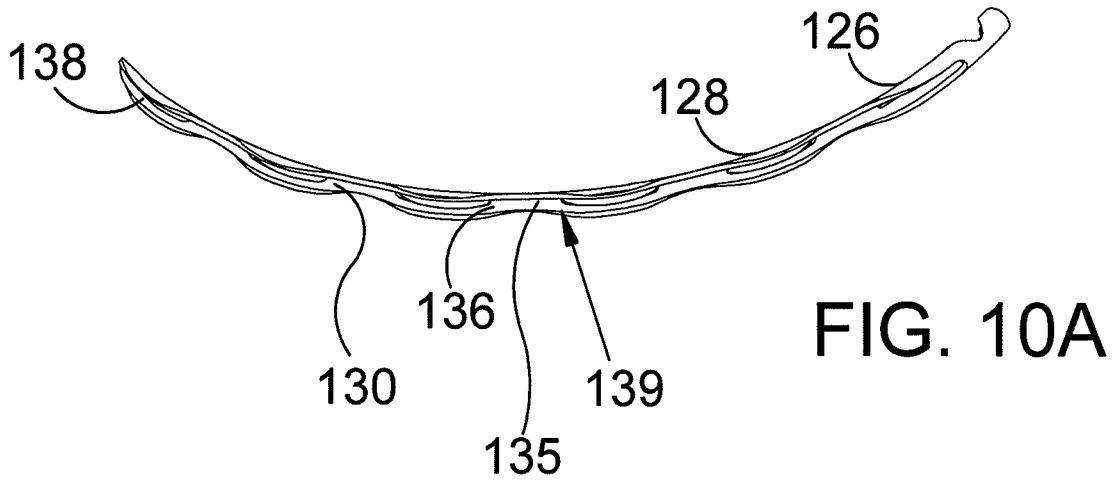

FIG. 9



12/29

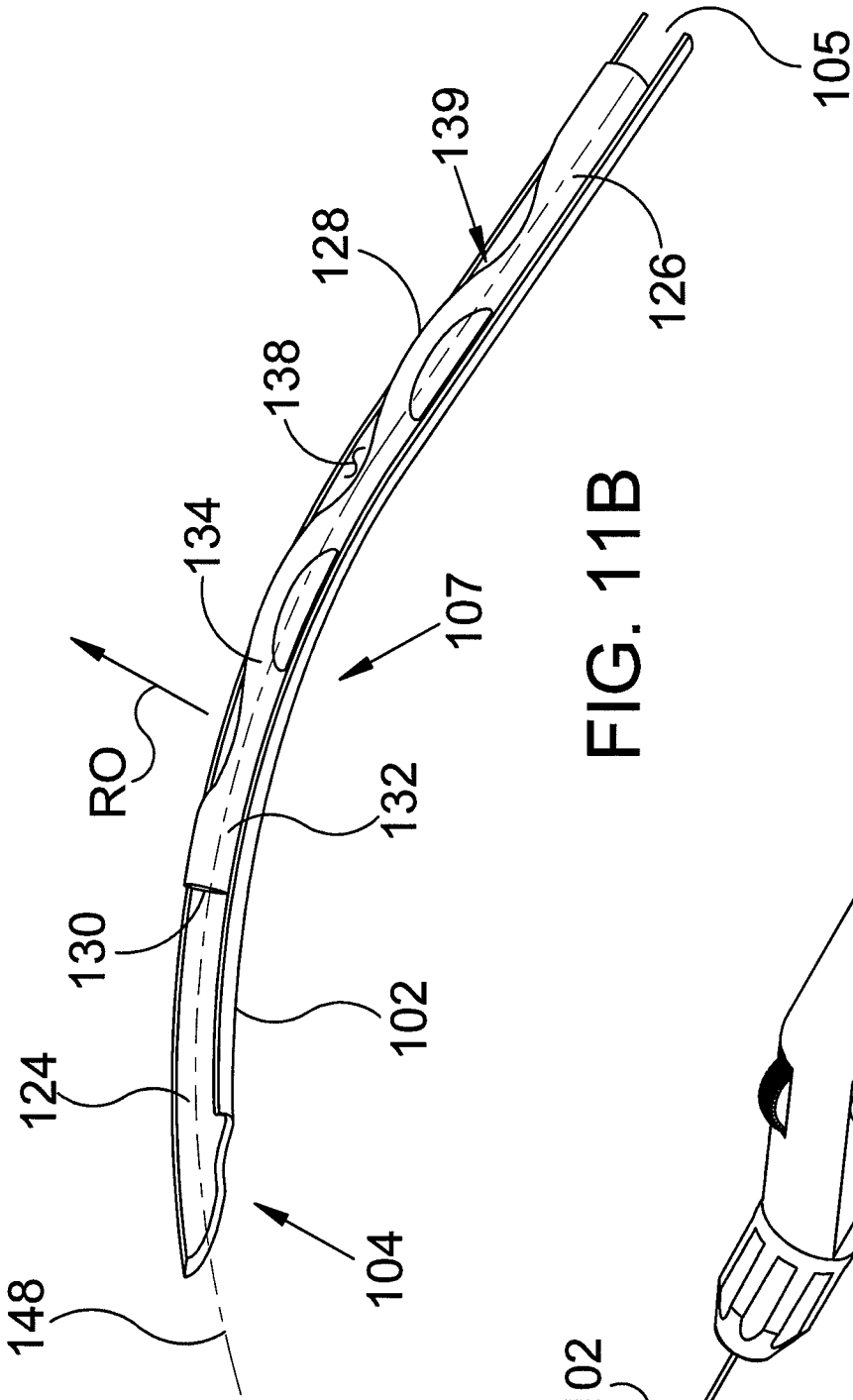

FIG. 11B

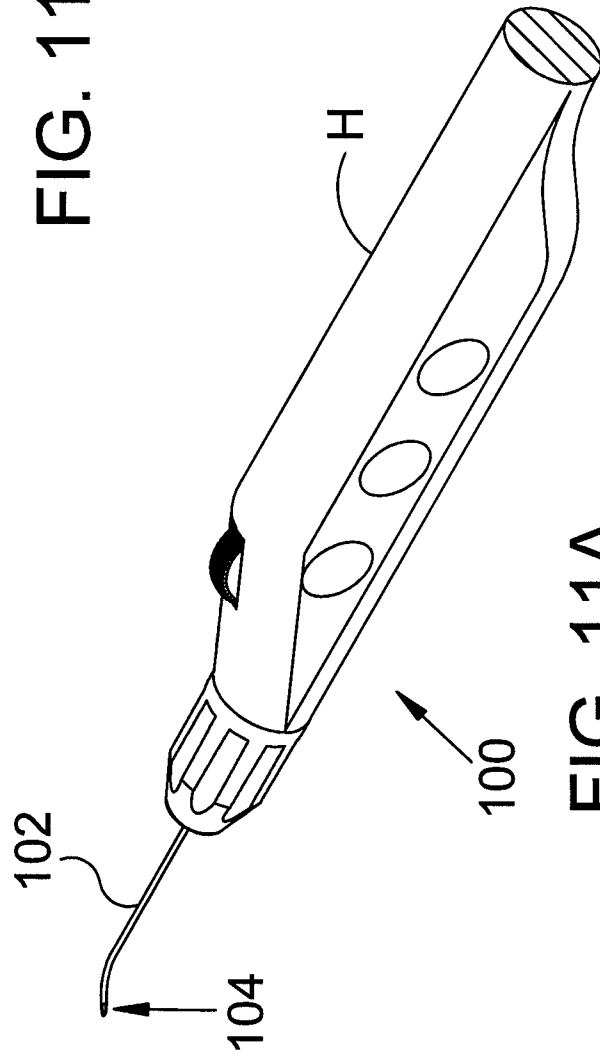

FIG. 11A

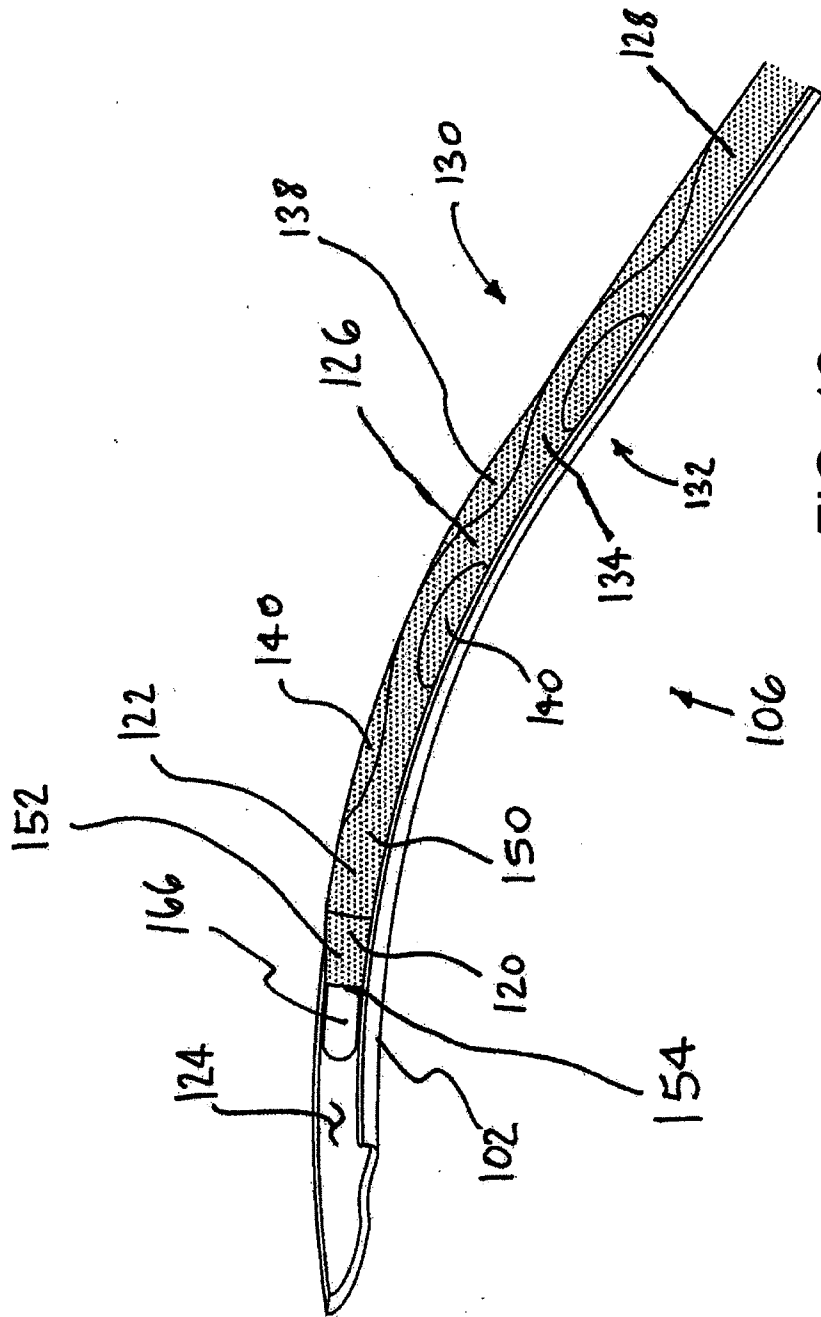

FIG. 12

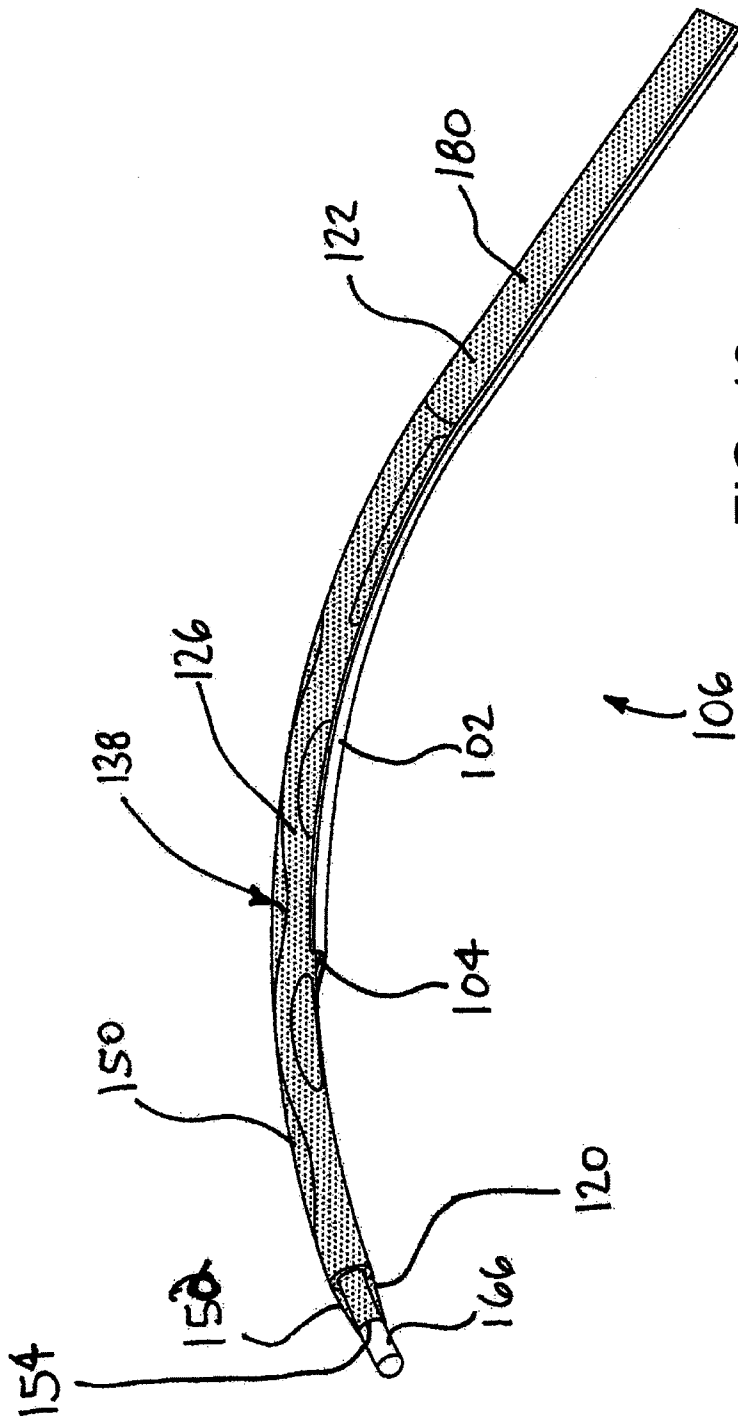

FIG. 13

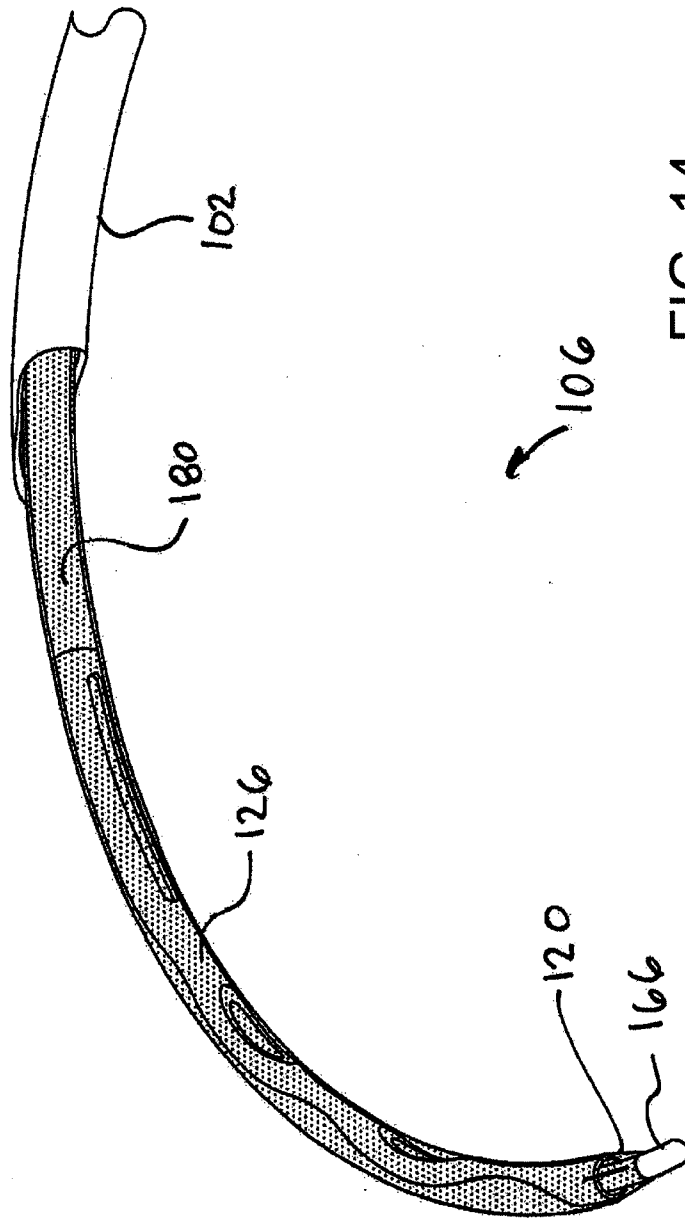

FIG. 14

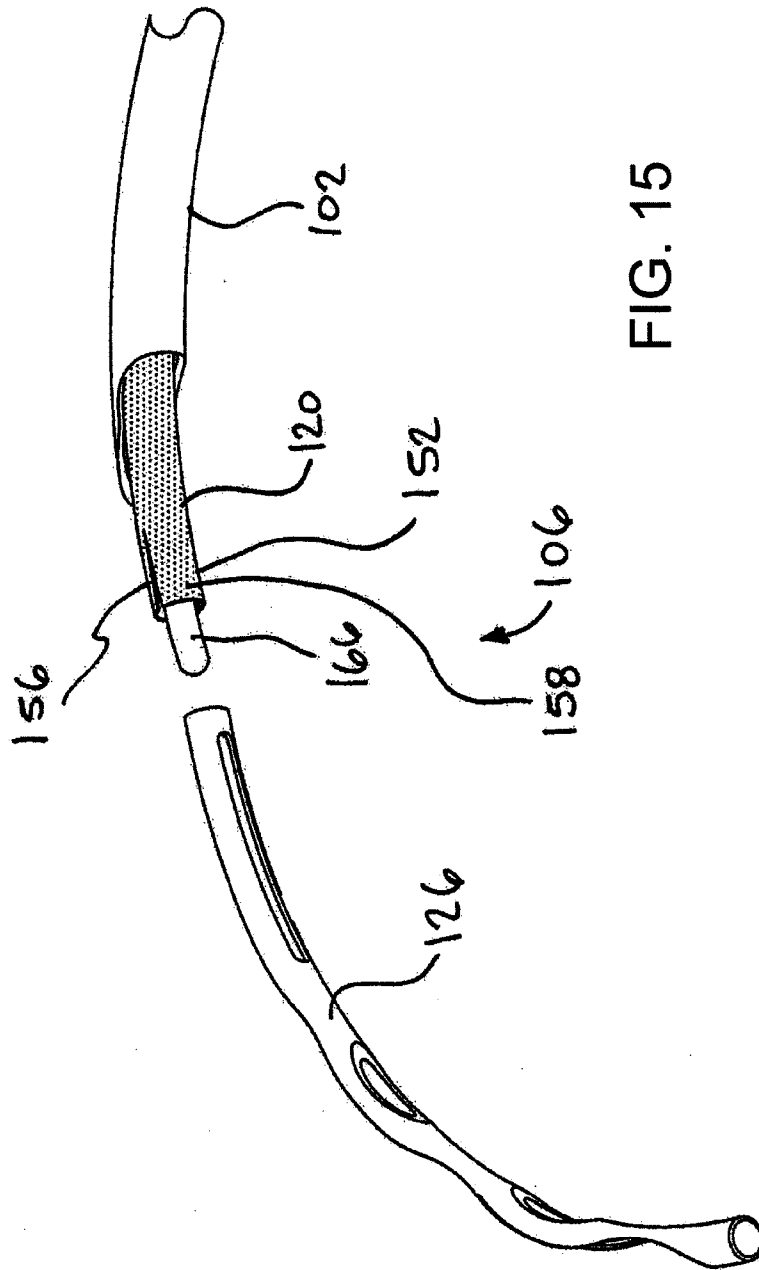

FIG. 15

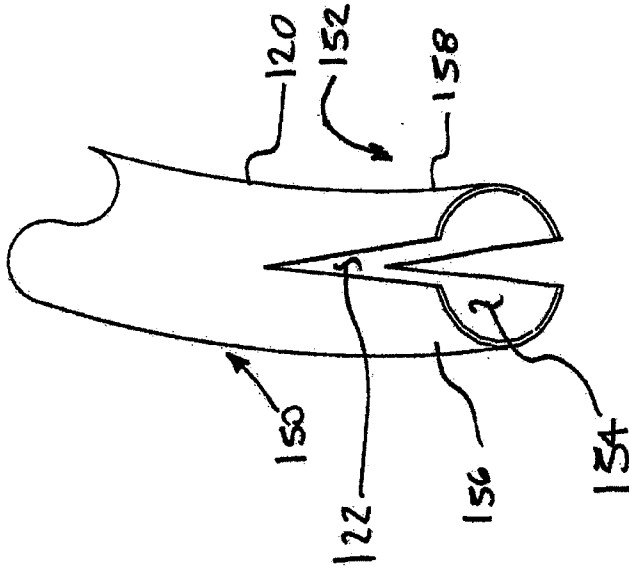

FIG. 16B

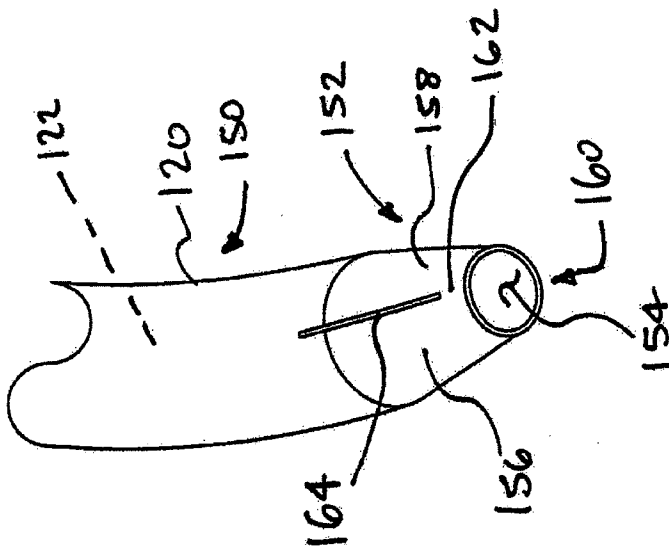

FIG. 16A

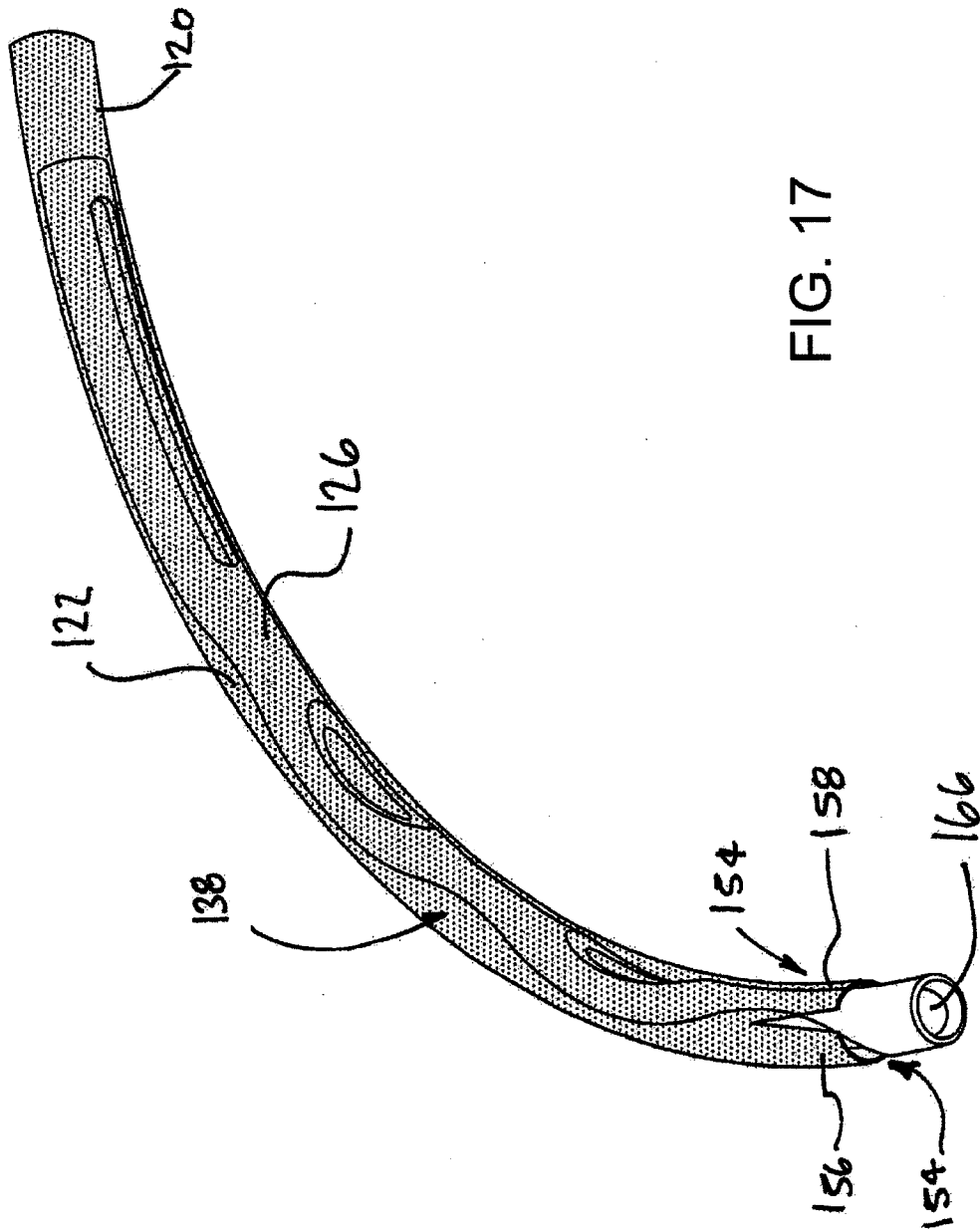

FIG. 17

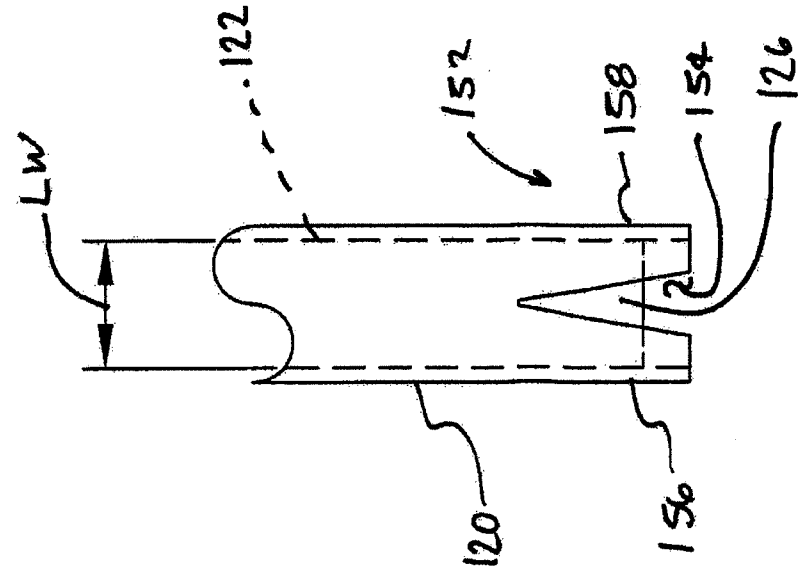

FIG. 18B

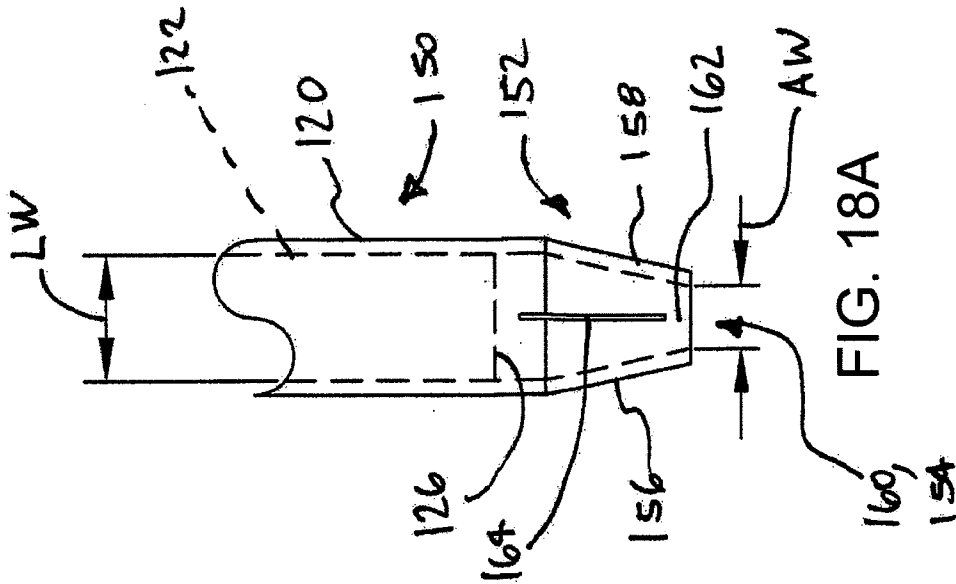
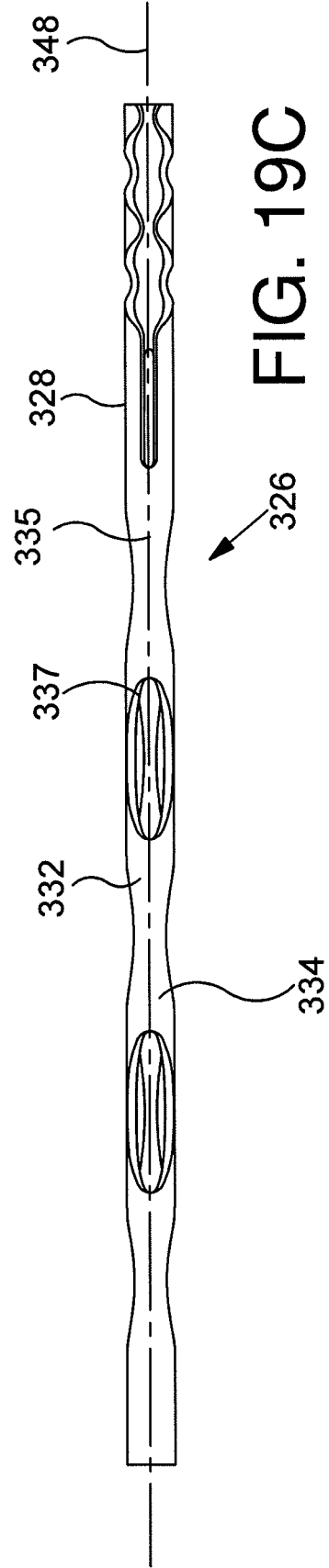
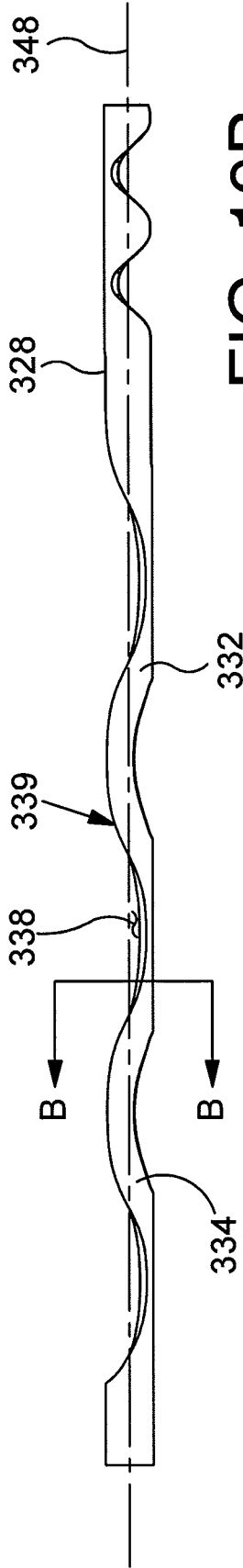
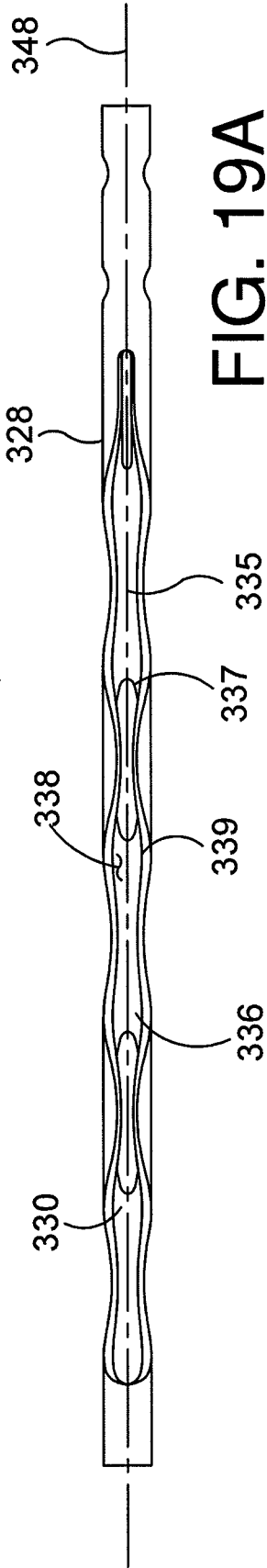

FIG. 18A



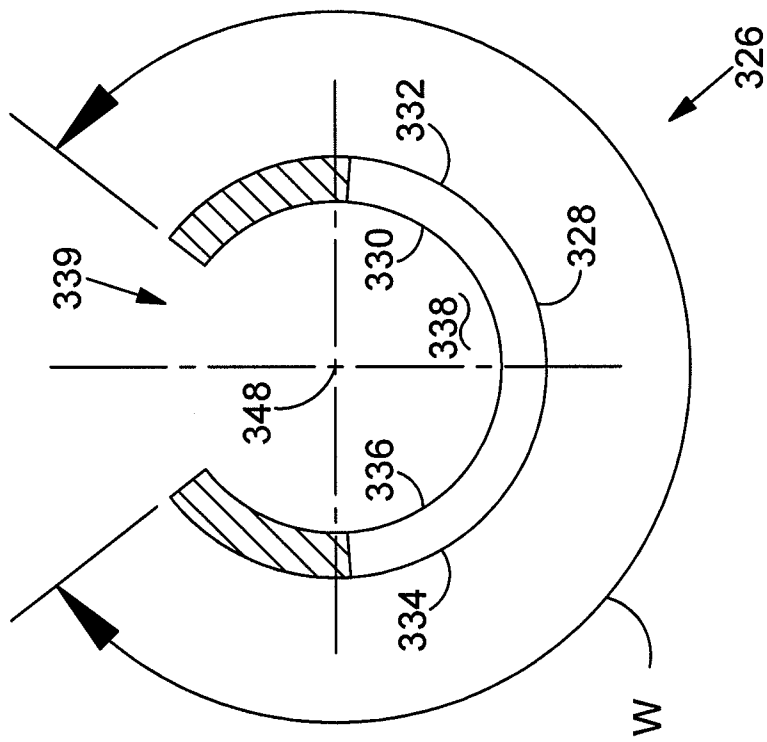

FIG. 20

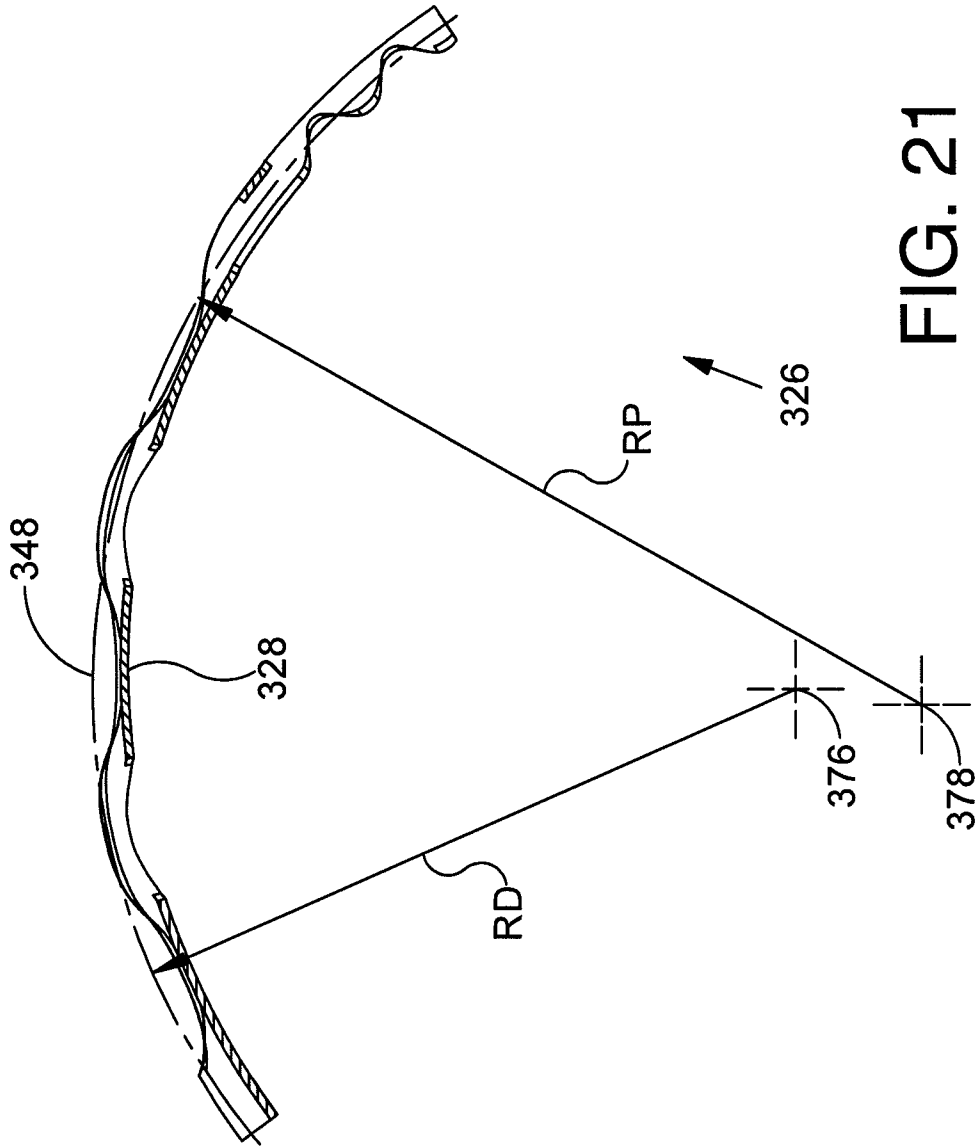

FIG. 21

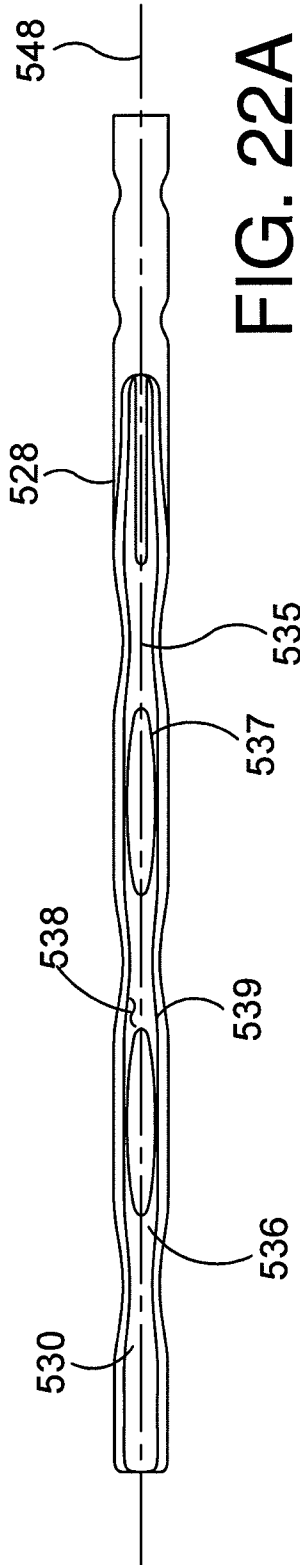

FIG. 22A

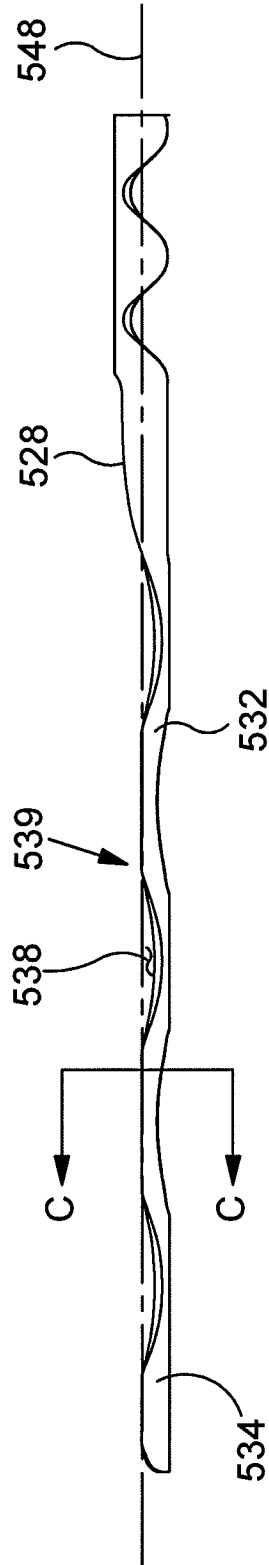

FIG. 22B

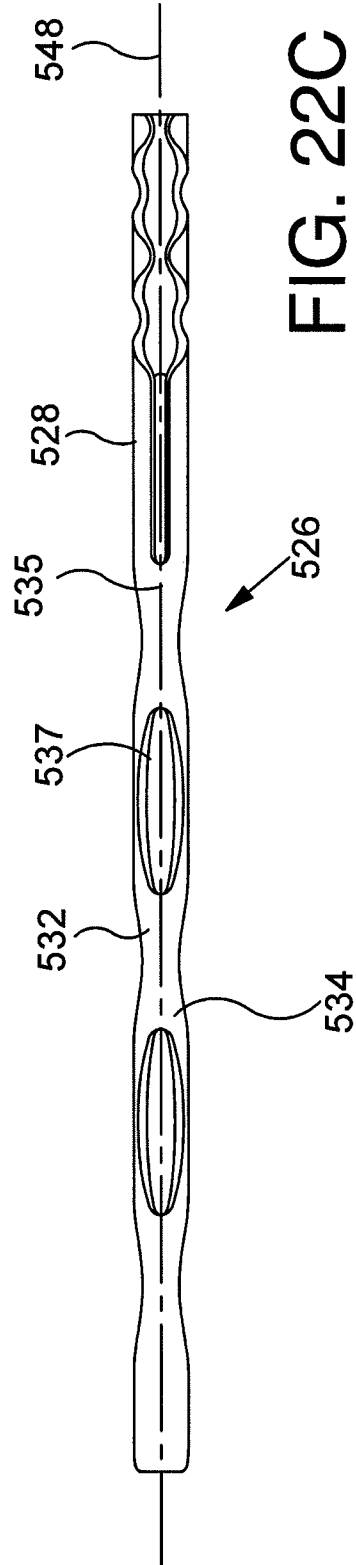

FIG. 22C

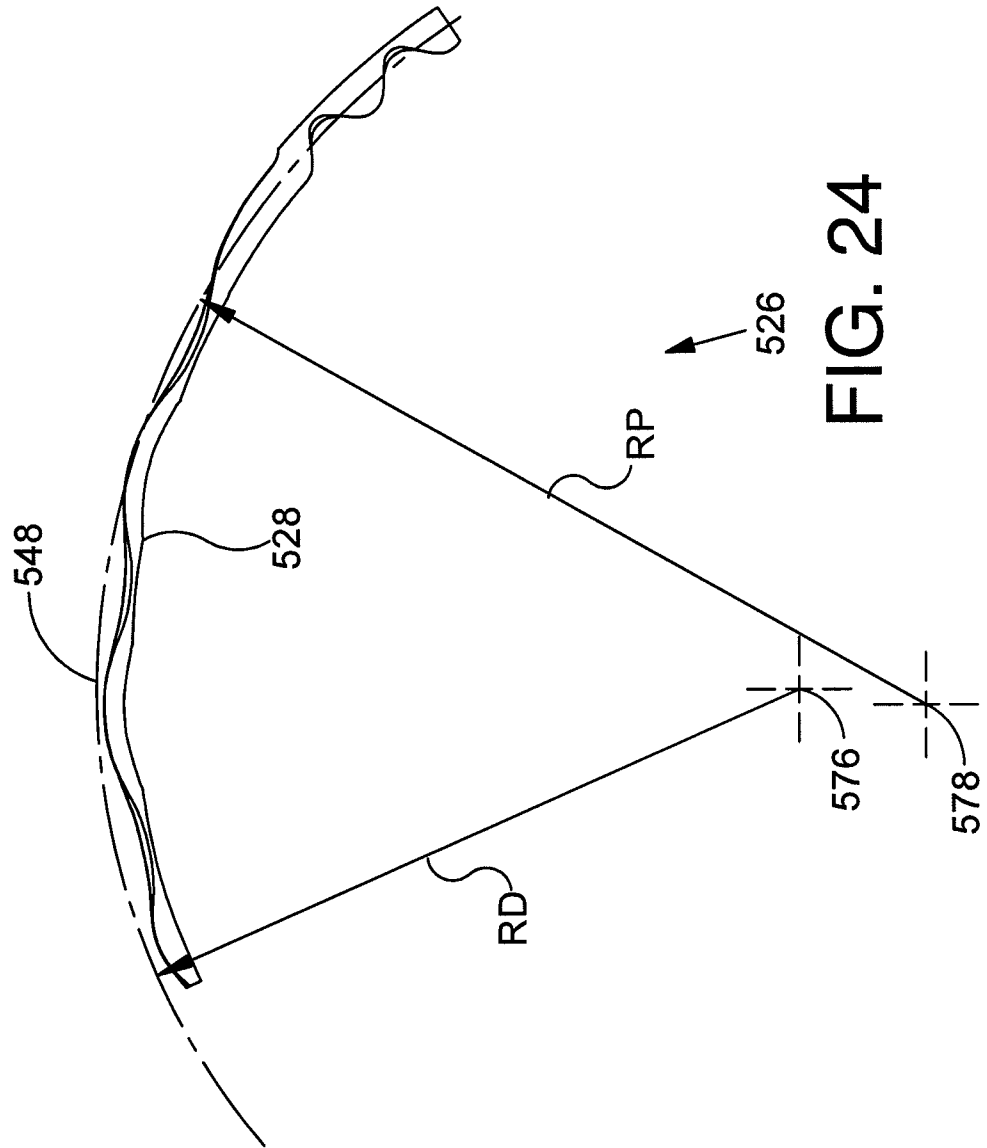

FIG. 24

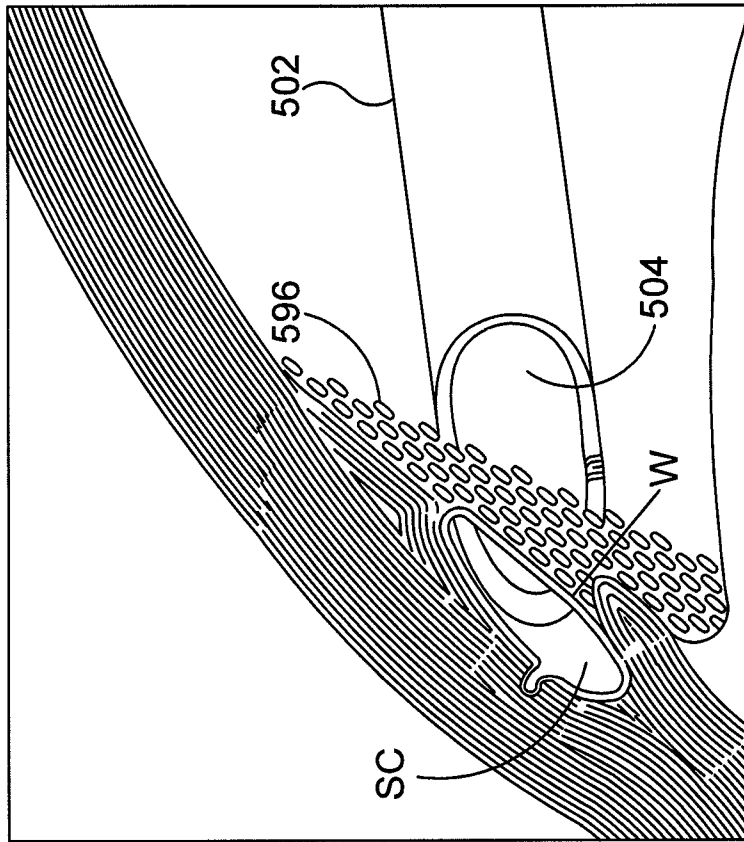

FIG. 26A

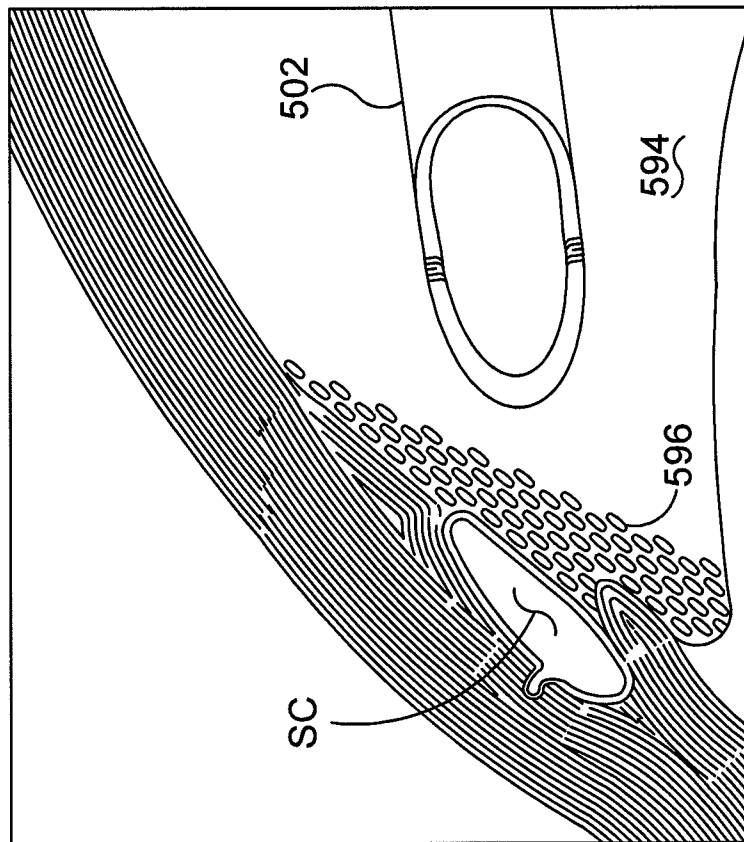

FIG. 26B

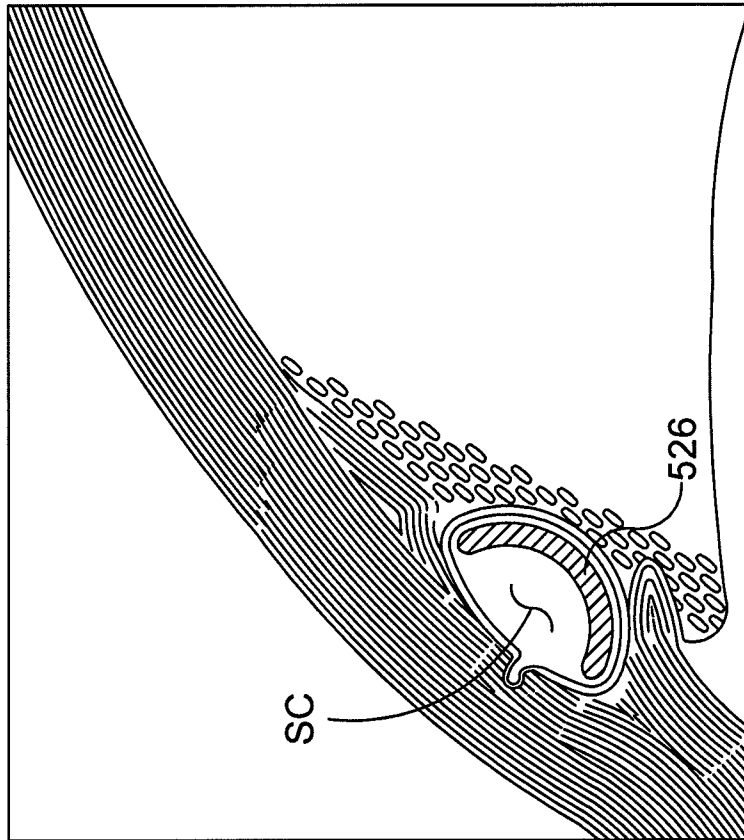

FIG. 26D

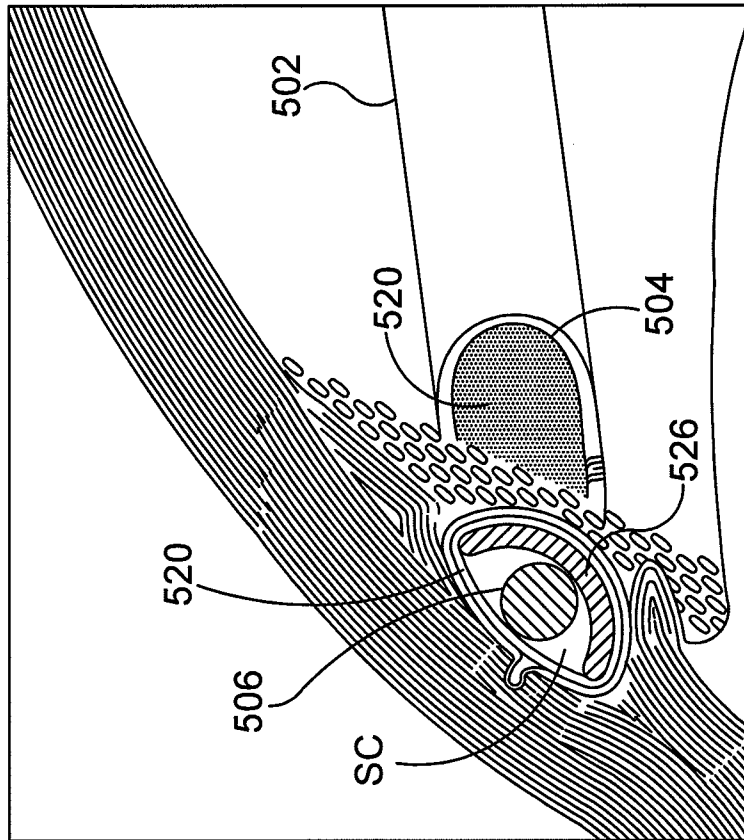

FIG. 26C

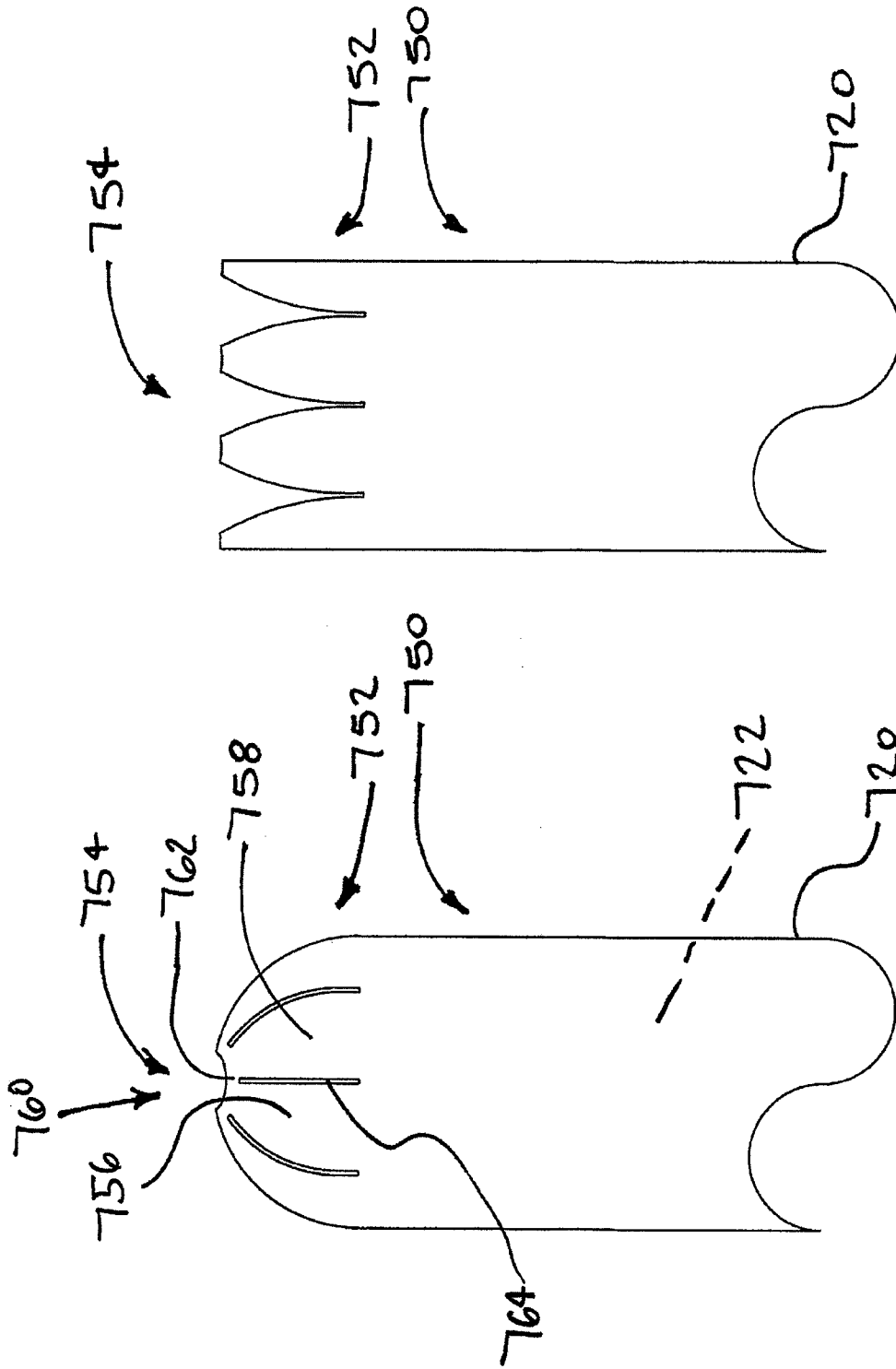

FIG. 27B

FIG. 27A

INTERNATIONAL SEARCH REPORT

International application No.
PCT/US 10/41589

A. CLASSIFICATION OF SUBJECT MATTER

IPC(8) - A61M 5/00 (2010.01)

USPC - 604/8-9

According to International Patent Classification (IPC) or to both national classification and IPC

B. FIELDS SEARCHED

Minimum documentation searched (classification system followed by classification symbols)
USPC - 604/8-9

Documentation searched other than minimum documentation to the extent that such documents are included in the fields searched
USPC - 606/107; 623/4.1, 5.11, 6.11-6.13 (see search terms below)

Electronic data base consulted during the international search (name of data base and, where practicable, search terms used)

PubWest (PGPB, USPT, EPAB, JPAB); Google

Search Terms: schlemm\$, ocular implant, pull\$, retract\$, remov\$, sheath, cover, frangible, ruptur, tear\$, implant, drug, pharmaceutical, agent, implant\$, insert\$, install\$, placed, resid\$

C. DOCUMENTS CONSIDERED TO BE RELEVANT

Category*	Citation of document, with indication, where appropriate, of the relevant passages	Relevant to claim No.
X --- Y	US 2009/0082863 A1 (SCHIEBER et al.) 26 March 2009 (26.03.2009) entire document, especially Abstract; para [0013]-[0016], [0019], [0056], [0067]-[0068], [0076], FIGS 4-6, 11-12, 14-15, 19	1-22 ----- 26-28, 44, 67-72
X --- Y	US 2009/0132040 A1 (FRION et al.) 21 May 2009 (21.05.2009) entire document, especially Abstract; para [0016]-[0017], [0047], [0062]; FIGS. 1-2, 5-8, 14	23 ----- 24-73
Y	US 2009/0069786 A1 (VESELY et al.) 12 March 2009 (12.03.2009) entire document, especially Abstract, para [000para[0030] - para[0032] and FIGS. 4-5.	24-73
A	US 5,246,452 A (SINNOTT) 21 September 1993 (21.09.1993) entire document.	1-73

Further documents are listed in the continuation of Box C.

* Special categories of cited documents:

- "A" document defining the general state of the art which is not considered to be of particular relevance
- "E" earlier application or patent but published on or after the international filing date
- "L" document which may throw doubts on priority claim(s) or which is cited to establish the publication date of another citation or other special reason (as specified)
- "O" document referring to an oral disclosure, use, exhibition or other means
- "P" document published prior to the international filing date but later than the priority date claimed

- "T" later document published after the international filing date or priority date and not in conflict with the application but cited to understand the principle or theory underlying the invention
- "X" document of particular relevance; the claimed invention cannot be considered novel or cannot be considered to involve an inventive step when the document is taken alone
- "Y" document of particular relevance; the claimed invention cannot be considered to involve an inventive step when the document is combined with one or more other such documents, such combination being obvious to a person skilled in the art
- "&" document member of the same patent family

Date of the actual completion of the international search

30 August 2010 (30.08.2010)

Date of mailing of the international search report

07 SEP 2010

Name and mailing address of the ISA/US

Mail Stop PCT, Attn: ISA/US, Commissioner for Patents
P.O. Box 1450, Alexandria, Virginia 22313-1450
Facsimile No. 571-273-3201

Authorized officer:

Lee W. Young

PCT Helpdesk: 571-272-4300
PCT OSP: 571-272-7774