

(19)



(11)

EP 3 028 958 B1

(12)

EUROPEAN PATENT SPECIFICATION

(45) Date of publication and mention of the grant of the patent:
19.07.2017 Bulletin 2017/29

(51) Int Cl.:
B65D 85/72 (2006.01) B65D 25/36 (2006.01)
B65D 1/46 (2006.01) B65D 77/20 (2006.01)

(21) Application number: **15003402.3**

(22) Date of filing: **30.11.2015**

(54) THERMOFORMED CONTAINER

WARMGEFORMTER BEHÄLTER

RÉCIPIENT THERMOFORMÉ

(84) Designated Contracting States:
AL AT BE BG CH CY CZ DE DK EE ES FI FR GB GR HR HU IE IS IT LI LT LU LV MC MK MT NL NO PL PT RO RS SE SI SK SM TR
Designated Extension States:
BA ME

(72) Inventor: **Hernández Socastro, José Manuel**
28043 Madrid (ES)

(74) Representative: **Maldonado Jordan, Julia**
Linares, 7 - 3
46018 Valencia (ES)

(30) Priority: **02.12.2014 ES 201400998**

(56) References cited:
CA-A1- 2 830 032 DE-A1- 2 755 996
DE-U1-202007 016 006 US-A1- 2007 017 920

(43) Date of publication of application:
08.06.2016 Bulletin 2016/23

(73) Proprietor: **Mecánica y Tecnología Alimentaria, S.L.**
28043 Madrid (ES)

EP 3 028 958 B1

Note: Within nine months of the publication of the mention of the grant of the European patent in the European Patent Bulletin, any person may give notice to the European Patent Office of opposition to that patent, in accordance with the Implementing Regulations. Notice of opposition shall not be deemed to have been filed until the opposition fee has been paid. (Art. 99(1) European Patent Convention).

Description

Object of the invention.

[0001] The object of the invention is a thermoformed container with a hollow body which has a flat base, a sidewall extending from the periphery of the base, having said sidewall an upper end delimitating the mouth of the container and extending towards the exterior of the container in form of a perimetric flange; having the hollow body of the container an upper portion with a constant cross section, bearing an external decoration web, and a lower portion comprised between the upper portion and the base of the container having a tapering structure in descending direction.

Field of application of the invention

[0002] The thermoformed container of the invention is preferably, although not exclusively, applicable to the packing of food products.

State of the art

[0003] Currently, different types of plastic thermoformed containers are known in the market aimed at the food packing field, for packing various food products, such as yogurt or dairy dessert products.

[0004] A previous embodiment of this type of containers, comprising the features of the preamble of claim 1, and described in document CA 2830032 A1 has a hollow body with a flat base, its periphery extending in a sidewall which has an upper end delimitating the mouth of the container and extending towards the exterior of the container in form a perimetric flange. Said container, the same as other existing in the market, has in its hollow body an upper portion with constant cross section bearing an external decoration web and a lower portion with tapering cross section in descending direction, comprised between the mentioned upper portion and the base of the container.

[0005] In this type of containers, it is known the lower portion to have a curved profile to facilitate the extraction of most of the product contained within the container by means of a small spoon.

[0006] These type of thermoformed containers, made out from a sheet of plastic material, have a lower strength in the transition area between the upper portion and the lower portion of the container, being necessary to oversize the thickness of the plastic sheet in order that said transition area has the sufficient strength to permit the nesting and transport of the containers in a safe form.

[0007] Said oversizing determines the rest of the parts of the container to have a larger thickness than necessary, deriving therefrom an increase of the plastic material necessary for the manufacture of the container.

[0008] Document DE 2755996 A1 discloses a cup-shaped container for milk coagulates such a yoghurt, etc.

The container has a base, a sidewall and a removable lid. The sidewall has bosses and recesses on the inside spaced round the periphery for at least part of its height. The bosses and recesses can be formed in the bottom portion and/or in a funnel section joining onto it, or on a stepped portion and extending into the sidewall. The bosses and recesses can be rib-shaped, all of the same width and in line with each other. The ribs can be interrupted at one or more levels by a bead protruding inwards, the bead being situated between the base portion and the funnel section.

[0009] Document DE 202007016006 describes a container for containing liquid and/or pasty products, in particular dairy products, comprising a cup-like shell forming an inner boundary surface of the container, and a cover which covers at least partially an outer limiting surface of the shell. At least one radially inwardly extending indentation is arranged in a peripheral surface of the base region. The indentation is provided with an upwardly facing outer boundary surface, and a lower edge of the cover can be placed against the upwardly facing boundary surface of the bottom region.

[0010] Document US 2007017920 A1 discloses a blow molded plastic container configured to hold food or food-related products, including cheese. In a first embodiment, the container includes extended vertical ribs that have a height that spans at least about ninety-five percent of a height of a lower portion of the container. In a second embodiment, the container includes a reinforced annular leg that is greater than the thickness of the container wall. In a third embodiment, the stacking bead is positioned between the lower and upper container walls, and the lower container wall is inwardly offset from the upper container wall. In a fourth embodiment, the container bottom is reinforced with continuous ribbing.

[0011] The present inventor does not know the existence of prior embodiments permitting to solve in a satisfactory way the above mentioned drawback.

Description of the invention

[0012] The thermoformed object of this invention, of the type described in the precharacterizing part of the main claim, has technical characteristics aimed at solving the above mentioned drawback and to provide the body of the container with a higher strength to compression in the weakest area, which is the transition area between the upper portion with a uniform cross section and the lower portion with a tapering cross section, making the use of an oversized plastic sheet for the manufacture of the container unnecessary.

[0013] Another objective of the invention is to obtain the reduction of the quantity of plastic material for the manufacture of the container, for needing a lesser thickness of the material in the less weak areas of the same.

[0014] To that end and according to the invention, the sidewall of the container has wedge like recesses arranged in correspondence with the upper end of the lower

portion of the container and distributed around the body of the container; and groups of reinforcement hollow embossments which protrude from the body of the container and are vertically oriented.

[0015] The mentioned wedge like recesses are arranged in the lower portion of the container and distributed around the hollow body of the container, with an upper end of the wedge like recesses coinciding with the upper end of the lower portion of the container.

[0016] The mentioned reinforcement embossments start from the upper portion of the container and end in an intermediate area of the lower portion of the container, being the upper ends of said reinforcements embossments arranged under the external decoration web.

[0017] The wedge like recesses, in number of three or more, arranged at the same distance to one another, have the object to reinforce the weakest part of the container, which is precisely the lower end of the upper portion, that is, the place in which the decoration web ends up, beginning the lower portion of the container.

[0018] These wedge like recesses have an effect similar to load beams in the weaker part of the container, transmitting a part of the loads to a lower area of the container, which has a smaller section and therefore, is stronger.

[0019] The above mentioned reinforcement embossments, have as well the object of reinforcing the container as they start from the upper portion of the container, so that the decoration web overlaps them extending said embossments along the lower portion up to an area with a higher resistance.

[0020] This features bring about improvements in respect to the current containers as they improve the resistance to compression of the container (manufacture, nesting for transport and storage, etc) and bring savings of the plastic material for its manufacture of about 10%.

Description of the drawings

[0021] To complete the description and with the aim to facilitate the understanding of the features of the invention a set of drawings is annexed to this description in which in an illustrative, but not limiting way, the follow has been shown:

- Figure 1 shows a diagrammatic front view of a thermoformed container, according to the invention.

Preferred embodiment of the invention

[0022] The thermoformed container shown in Figure 1 comprises a hollow body (1) with a flat base (11) a lateral wall delimitating in the end opposite to the base the mouth (12) of the container. The container shows a perimetric flange (13) around the mouth (12). The hollow body (1) has an upper portion (14) with a constant cross section, for example cylindrical cross section, bearing an external decoration web (2) and a lower portion (15) with tapering

cross section in descending direction, comprised between the upper portion (14) and the base (11).

[0023] In this case, the said lower portion (15) has a curved convex profile in its external face. The lateral wall of the container has wedge like recesses (16) arranged in correspondence with the upper end of the lower portion (15) and distributed around the body of the container.

[0024] The wedge like recesses (16) are located in the lower portion (15) of the hollow body (1) and have upper ends coinciding with the upper end of the lower portion (15) and a depth which decreases towards the lower area.

[0025] Said lateral wall has as well groups of reinforcement embossments (17) which are hollow, elongated, protruding from the hollow body (1) of the container.

[0026] The above mentioned reinforcement embossments (17) are directed vertically starting from the upper portion (14) of the container and extending to an intermediate area of the lower portion (15), increasing the resistance to the compression of the container.

[0027] It has been foreseen that the container has three or more wedge like recesses (16) and a similar number of groups of reinforcement embossments (17) regularly distributed around the container.

[0028] As can be observed in the annexed figure, the external decoration web (2) covers the part of the reinforcement embossments (17) defined in the upper portion (14) of the container.

[0029] After having sufficiently described the nature of the invention, as well as a preferred embodiment of the same, it is stated to all effects that the materials, shape, size and arrangement of the described elements can be modified, whenever the changes do not mean the alteration of the essential characteristics of the invention, which is defined by the following claims.

Claims

1. Thermoformed container; comprising a hollow body (1) having a flat base (11), extending around its periphery in a sidewall with an upper end delimitating the mouth (12) of the container which extends towards the exterior of the container in form of a perimetric flange (13); the hollow body (1) having an upper portion (14) with a constant cross section bearing an external decoration web (2); and a lower portion (15) comprised between the upper portion (14) and the base (11), having a tapering cross section in descending direction; **characterized in that** the sidewall of the container has wedge like recesses (16) arranged in the lower portion (15) and distributed around the hollow body (1) of the container, the upper ends of said wedge like recesses (16) coinciding with the upper end of the lower portion (15), and groups of reinforcement embossments (17) which are hollow and elongated, protruding from the body of the container and being oriented vertically;

said reinforcement embossments (17) starting from the upper portion (14) of the container and ending in an intermediate area of the lower portion (15), upper ends of said reinforcement embossments (17) being located under the external decoration web (2).

2. Container, according to claim 1, **characterized in that** the wedge like recesses (16) have a depth which decreases towards the lower area.
3. Container, according to any of the previous claims, **characterized** for comprising three or more wedge like recesses (16) and a similar number of groups of reinforcement embossments (17) regularly distributed on the periphery of the container.
4. Container, according to any of the previous claims, **characterized in that** the lower portion (15) has a curved convex profile in its external face.

Patentansprüche

1. Thermogeformter Behälter; umfassend einen Hohlkörper (1), der einen flachen Boden (11) aufweist, der sich um seinen Umfang in einer Seitenwand mit einem oberen Ende erstreckt, das die Öffnung (12) des Behälters begrenzt, welches sich zum Äußeren des Behälters in Form eines Umfangsflansches (13) erstreckt; wobei der Hohlkörper (1) einen oberen Abschnitt (14) mit einem konstanten Querschnitt, der einen äußeren Ziersteg (2) trägt; und einen unteren Abschnitt (15), der zwischen dem oberen Abschnitt (14) und dem Boden (11) enthalten ist, der einen sich verjüngenden Querschnitt in absteigender Richtung hat, aufweist; **dadurch gekennzeichnet, dass** die Seitenwand des Behälters keilartige Aussparungen (16), die in dem unteren Abschnitt (15) angeordnet und um den Hohlkörper (1) des Behälters herum verteilt sind, wobei die oberen Enden der keilartigen Aussparungen (16) mit dem oberen Ende des unteren Abschnitts (15) zusammenfallen, und Gruppen von Verstärkungserhebungen (17), welche hohl und länglich sind, die von dem Körper des Behälters vorstehen und vertikal ausgerichtet sind, aufweist; wobei die Verstärkungserhebungen (17) von dem oberen Abschnitt (14) des Behälters beginnen und in einem Zwischenbereich des unteren Abschnitts (15) enden, wobei die oberen Enden der Verstärkungserhebungen (17) unter dem äußeren Ziersteg (2) liegen.
2. Behälter nach Anspruch 1, **dadurch gekennzeichnet, dass** die keilartigen Aussparungen (16) eine Tiefe haben, welche zu dem unteren Bereich hin abnimmt.
3. Behälter nach einem der vorherigen Ansprüche, **da-**

durch gekennzeichnet, dass er drei oder mehr keilartige Aussparungen (16) und eine ähnliche Anzahl an Gruppen von Verstärkungserhebungen (17), die regelmäßig auf dem Umfang des Behälters verteilt sind, umfasst.

4. Behälter nach einem der vorherigen Ansprüche, **dadurch gekennzeichnet, dass** der untere Abschnitt (15) ein gekrümmtes konvexes Profil auf seiner äußeren Seite aufweist.

Revendications

1. Conteneur thermoformé; comprenant un corps creux (1) ayant une base plate (11), s'étendant autour de sa périphérie sur une paroi latérale avec une extrémité supérieure délimitant l'ouverture (12) du conteneur qui s'étend vers l'extérieur du conteneur sous la forme d'une bride périphérique (13); le corps creux (1) ayant une portion supérieure (14) avec une section transversale constante portant une bande de décoration externe (2); et une portion inférieure (15) comprise entre la portion supérieure (14) et la base (11), ayant une section transversale effilée dans un sens descendant; **caractérisé en ce que** la paroi latérale du conteneur a des renforcements en forme de coin (16) disposés dans la portion inférieure (15) et répartis autour du corps creux (1) du conteneur, les extrémités supérieures desdits renforcements en forme de coin (16) coïncidant avec l'extrémité supérieure de la portion inférieure (15), et des ensembles de bossages de renforcement (17) qui sont creux et longilignes, faisant saillie du corps du conteneur et étant orientés verticalement; lesdits bossages de renforcement (17) partant de la portion supérieure (14) du conteneur et terminant dans une zone intermédiaire de la portion inférieure (15), les extrémités supérieures desdits bossages de renforcement (17) étant situées sous la bande de décoration externe (2).
2. Conteneur, selon la revendication 1, **caractérisé en ce que** les renforcements en forme de coin (16) ont une profondeur qui décroît vers la zone inférieure.
3. Conteneur, selon l'une quelconque des revendications précédentes, **caractérisé en ce qu'il** comprend trois ou plusieurs renforcements en forme de coin (16) et un nombre similaire d'ensembles de bossages de renforcement (17) répartis régulièrement sur la périphérie du conteneur.
4. Conteneur, selon l'une quelconque des revendications précédentes, **caractérisé en ce que** la portion inférieure (15) a un profil convexe incurvé sur sa face externe.

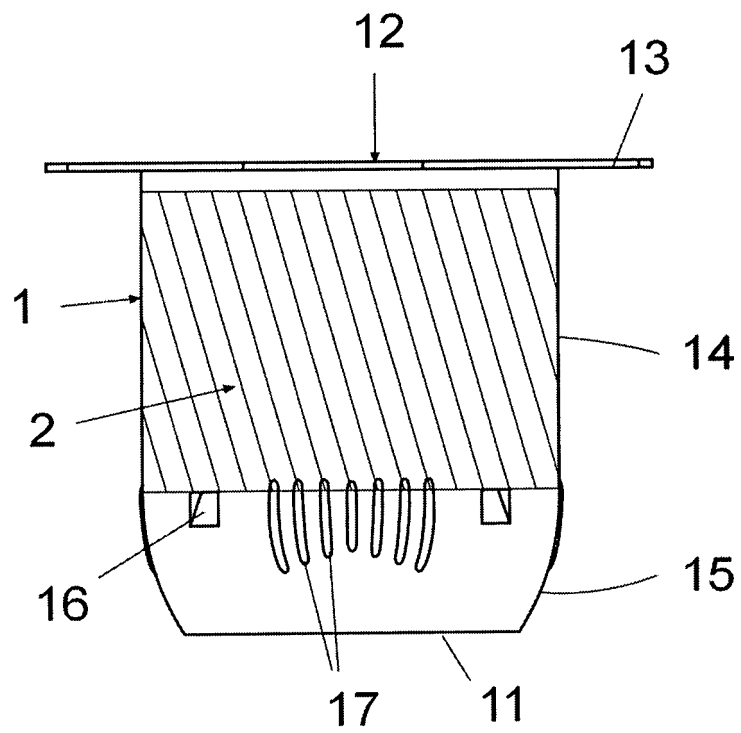

Fig. 1

REFERENCES CITED IN THE DESCRIPTION

This list of references cited by the applicant is for the reader's convenience only. It does not form part of the European patent document. Even though great care has been taken in compiling the references, errors or omissions cannot be excluded and the EPO disclaims all liability in this regard.

Patent documents cited in the description

- CA 2830032 A1 [0004]
- DE 2755996 A1 [0008]
- DE 202007016006 [0009]
- US 2007017920 A1 [0010]