



US 20040194251A1

(19) **United States**

(12) **Patent Application Publication**
Overvaag et al.

(10) **Pub. No.: US 2004/0194251 A1**

(43) **Pub. Date: Oct. 7, 2004**

(54) **UPRIGHT VACUUM CLEANER EQUIPPED WITH ELECTRIFIED STRETCH HOSE AND WAND**

Related U.S. Application Data

(60) Provisional application No. 60/460,700, filed on Apr. 4, 2003.

(76) Inventors: **Chad D. Overvaag**, Danville, KY (US); **Jeffrey T. Roney**, Stanford, KY (US)

Publication Classification

(51) **Int. Cl.⁷ A47L 9/04**

(52) **U.S. Cl. 15/377**

Correspondence Address:
KING & SCHICKLI, PLLC
247 NORTH BROADWAY
LEXINGTON, KY 40507 (US)

(57) **ABSTRACT**

An upright vacuum cleaner includes a nozzle assembly having an intake opening. A handle assembly is pivotally connected to the nozzle assembly. The vacuum cleaner also includes a suction generator and a dirt collection vessel. In addition, the vacuum cleaner includes a flexible, electrified stretch hose.

(21) Appl. No.: **10/817,561**

(22) Filed: **Apr. 2, 2004**

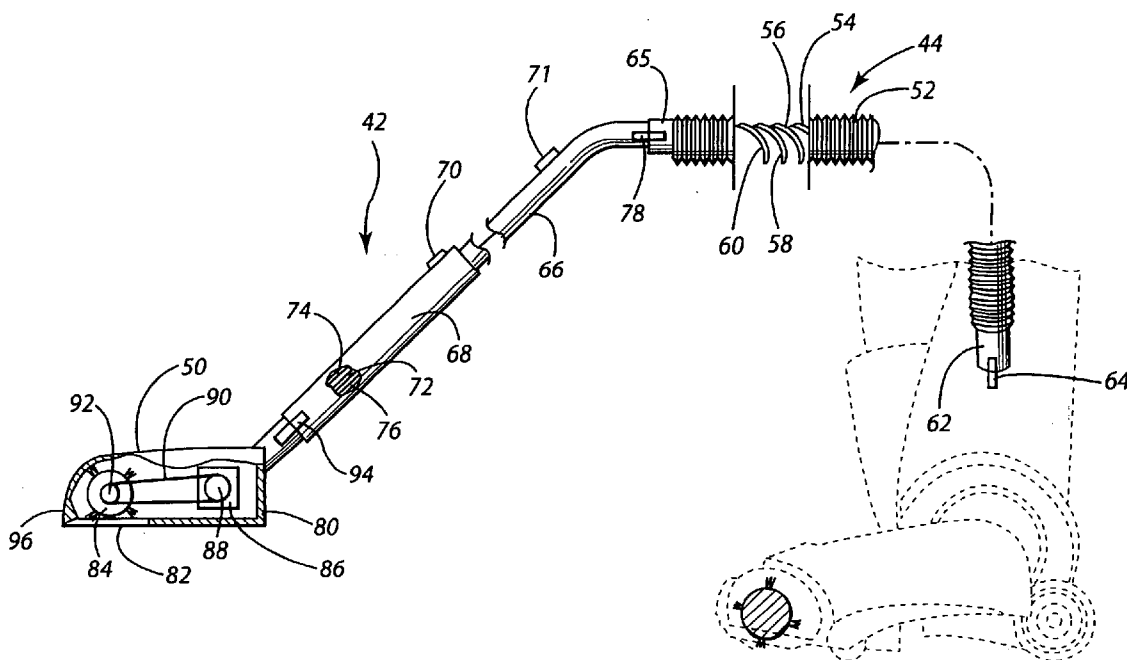

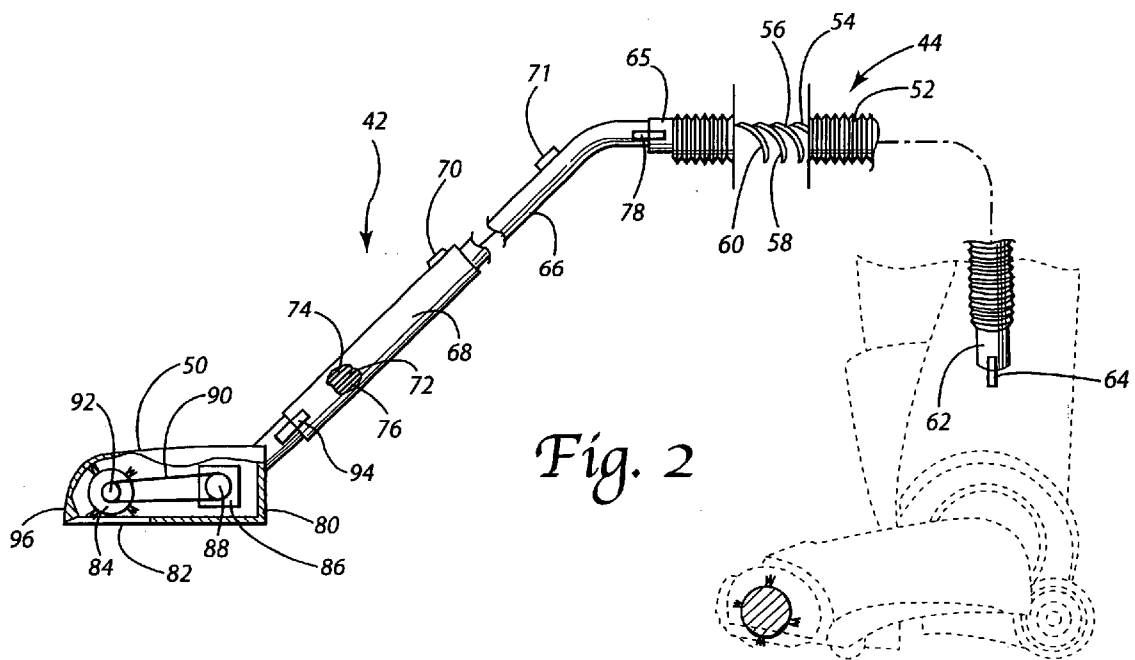

Fig. 2

UPRIGHT VACUUM CLEANER EQUIPPED WITH ELECTRIFIED STRETCH HOSE AND WAND

[0001] This application claims the benefit of U.S. Provisional Patent Application Serial No. 60/460,700 filed on Apr. 4, 2003.

TECHNICAL FIELD

[0002] The present invention relates generally to the floor care equipment field and, more particularly, to a floor cleaning apparatus having a nozzle assembly for cleaning a floor, a canister handle assembly with control handle pivotally connected to the nozzle assembly and an electrified stretch hose for powering a separate cleaning attachment.

BACKGROUND OF THE INVENTION

[0003] Upright vacuum cleaners of various shapes and designs have long been known in the art. Upright vacuum cleaners generally include a nozzle assembly having an intake opening, a handle assembly connected to the nozzle assembly, a suction generator for generating the negative pressure to draw dirt and debris into the vacuum cleaner and a dirt collection vessel in the form of a bag or cup for collecting dirt for disposal. While particularly useful and convenient for cleaning open floor areas, the dimensions of the nozzle assembly and/or the weight and structure of the overall vacuum cleaner prevent its effective use in certain applications. For example, the nozzle assembly may be too wide to fit in a narrow space between a wall and a heavy piece of furniture. Further, it should be appreciated that the nozzle assembly of the upright vacuum cleaner is not particularly adapted for cleaning the treads of a stairway, the cushions of a couch, along the top of baseboards, window-sills and draperies or for other above floor applications. Accordingly, most upright vacuum cleaners are also equipped with a flexible hose and sometimes a wand as well as one or more cleaning attachments for the hose and/or wand.

[0004] In the past, those cleaning attachments have generally included an upholstery brush and crevice tool. More recently, some upright vacuum cleaners have been equipped with a cleaning head including a rotary agitator connected to an air impeller. The airflow generated by the suction generator turns the impeller and drives the rotary agitator.

[0005] While such a design is useful for some applications, it should be appreciated that the airflow energy utilized to turn the impeller and drive the agitator is no longer available to carry entrained dirt and debris toward the dirt collection vessel of the vacuum cleaner. Accordingly, cleaning efficiency is compromised when the airflow is also used to drive a rotary agitator.

[0006] Recognizing this shortcoming, the present invention relates to an upright vacuum cleaner equipped with an electrified stretch hose capable of powering an electric motor for driving an agitator of a cleaning tool attachment, a light or other electrical feature. Advantageously, since the rotary agitator of the cleaning tool is driven by an electric motor rather than the airflow generated by the suction generator, that entire airflow remains available to entrain dirt and debris and draw it toward the dirt collection vessel of the vacuum cleaner. Accordingly, not only is the agitator driven more powerfully and at great speeds so as to better beat dirt

and debris from a surface being cleaned, but the full energy of the airstream remains available for drawing that dirt and debris to the dirt collection vessel. As a result the cleaning efficiency of the cleaning tool is greatly enhanced.

SUMMARY OF THE INVENTION

[0007] In accordance with the purposes of the present invention as described herein, an upright vacuum cleaner is provided. That upright vacuum cleaner incorporates a nozzle assembly including an intake opening and a handle assembly pivotally connected to the nozzle assembly. The upright vacuum cleaner also includes both a suction generator and a dirt collection vessel. These two structures may be carried on either the nozzle assembly or the handle assembly. Additionally, the upright vacuum cleaner includes a flexible, electrified stretch hose that may also be carried on either the nozzle assembly or the handle assembly as desired.

[0008] The invention may also include an electrified cleaning wand. Both the electrified cleaning wand (when provided) and the cooperating, flexible, electrified stretch hose include three insulated electrical conductors. The hose also includes a reinforcing wire for strength and structural integrity and a collapsible wall that allows the hose to be stretched for added length when cleaning.

[0009] The upright vacuum cleaner further includes a cleaning attachment and a first connector for securing that cleaning attachment to the hose and/or the wand. The cleaning attachment includes an electrical motor that receives electrical power through at least two insulated electrical conductors in the wand and the stretch hose. That electrical motor is connected to a rotary agitator carried in an intake opening in the cleaning attachment in order to drive the rotary agitator to provide more efficient and effective cleaning through the attachment than would otherwise be possible. Alternatively, the cleaning attachment may include a booster fan and the booster fan may be driven by the electrical motor in order to provide increased suction to the cleaning attachment. Additionally, the cleaning attachment may include a light that receives electrical power through the two insulated electrical conductors in the wand and the stretch hose.

[0010] In accordance with an additional aspect of the present invention a second connector may be provided for securing the wand to the stretch hose. In this embodiment the wand may be removed from the stretch hose and the hose directly connected to an attachment if desired.

[0011] In still another possible arrangement, the wand may include multiple sections. Those sections may be separate or alternatively may be telescoping in design.

[0012] The upright vacuum cleaner may also include at least one rotary agitator carried on the nozzle assembly in the intake opening. Further, the dirt collection vessel may take the form of a dirt filter bag or a dirt cup. The dirt cup may be substantially cylindrical in shape and include a tangentially directed inlet opening in order to take advantage of the cleaning action produced by cyclonic airflow if desired.

[0013] Still further, a control switch may be provided for selectively activating and deactivating the electrical motor on the cleaning attachment. That control switch may be carried on the wand or the cleaning attachment itself.

[0014] In accordance with yet another aspect of the present invention, a method is provided for increasing the cleaning versatility and performance of an upright vacuum cleaner. That method comprises equipping an upright vacuum cleaner with a flexible stretch hose and a powered cleaning attachment tool that may be selectively secured to the hose and used for certain cleaning applications. That method also includes equipping the flexible stretch hose and/or a wand (if present) with electrical conductors for powering the powered cleaning attachment. In addition the method includes equipping the powered cleaning attachment with a rotary agitator and cooperating rotary agitator drive motor. Further, the method includes equipping the powered cleaning attachment with a light source so that the work area may be better illuminated so that the operator can clearly see and thereby direct the cleaning attachment to provide more effective and efficient cleaning.

BRIEF DESCRIPTION OF THE DRAWING FIGURES

[0015] The accompanying drawings incorporated in and forming a part of the specification, illustrate several aspects of the present invention, and together with the description serve to explain certain principles of the invention. In the drawings:

[0016] FIG. 1 is a perspective view of an upright vacuum cleaner constructed in accordance with the teachings of the present invention; and

[0017] FIG. 2 is a schematical view providing a further detailed illustration of the structure of the present invention.

[0018] Reference will now be made in detail to the present preferred embodiment of the invention, an example of which is illustrated in the accompanying drawing.

DETAILED DESCRIPTION OF THE INVENTION

[0019] Reference is now made to FIG. 1 illustrating the floor cleaning apparatus 10 of the present invention. As illustrated the floor cleaning apparatus 10 is an upright vacuum cleaner. It should be appreciated, however, that the present invention could also take the form of an extractor and that the upright vacuum cleaner is merely being described in detail to illustrate the principles of the present invention.

[0020] The apparatus 10 includes a nozzle assembly 12 that includes an intake opening 14. The nozzle assembly also houses a rotary agitator 16 in the intake opening 14. The rotary agitator 16 may include tufts of bristles 18 or other cleaning structures such as wipers, beater bars and brushes for brushing and beating dirt from the nap of the underlying rug or carpet being cleaned.

[0021] The apparatus 10 further includes a handle assembly, generally designated by reference numeral 20. The handle assembly 20 is pivotally connected to the nozzle assembly 12. The handle assembly 20 includes a first housing section 22, a second, mating housing section 24 and a control handle 25. A suction generator 26, including a cooperating fan and drive motor, is housed in a compartment within the handle assembly 20. Additionally, the handle assembly 20 includes a cavity 28 that receives and holds a dirt collection vessel 30. The dirt collection vessel 30

illustrated takes the form of a dirt cup. The dirt cup may include a cylindrical internal chamber and a tangentially directed inlet in order to provide cyclonic airflow and take advantage of the cleaning benefits characteristic of such airflow if desired. Alternatively, the open cavity 28 may be replaced with an enclosed compartment that receives a filter bag in a manner known in the art.

[0022] During normal floor cleaning operation, the tufts of bristles 18 on the rotary agitator 16 beat and lift dirt and debris from the nap of an underlying carpet or rug being cleaned. That dirt and debris is drawn into the intake opening 14 in the nozzle assembly 12 by means of the negative pressure and the resulting airflow produced by the suction generator 26. Accordingly, air entrained with dirt and debris is drawn through a conduit (not shown) and delivered through the wand 42 and the stretch hose 44 to the inlet (not shown) of the dirt collection vessel 30. Dirt and debris is trapped in the vessel 30 while substantially clean air is drawn through a filter (not shown) into the compartment housing the suction generator 26. That relatively clean air passes over the motor of the suction generator 26 to provide cooling and is then discharged through a final filter (not shown) and the exhaust port 38 into the environment.

[0023] As best illustrated in FIG. 2, the wand 42 and hose 44 of the upright vacuum cleaner 10 of the present invention are electrified in order to allow the user to operate a powered cleaning attachment 50. More particularly, the stretch hose 44 includes a flexible resin body 52 that is molded around a coiled reinforcing wire 54, a first insulated electrical conductor 56, a second insulated electrical conductor 58, and a third insulated electrical conductor 60. The wall of the resin body 52 is collapsible with resilient memory to assume a retracted or shortened length. Thus, when the wand 42 and hose 44 are carried on the apparatus 10 in their designated positions as shown in FIG. 1 for normal floor cleaning, the stretch hose assumes a static length A. In contrast, when the wand 42 is used for above floor cleaning, the hose 44 may be stretched to a length B where B is greater than A by extending the collapsible wall of the body 58. The added length provided by the stretch hose 44 is particularly useful when trying to clean with the wand 42 and any associated cleaning attachments. This is because larger areas may be cleaned without having to move the main body of the apparatus 10. Further, this benefit is achieved without having to store an extra length of hose since the resilient memory of the hose 44 returns the hose to a retracted condition and shorter length A when not in use.

[0024] As illustrated, the first end of the hose 44 is connected to a hose conduit or fitting 62 carried on the handle assembly 20 of the upright vacuum cleaner. A two section electrical plug or junction box 64 provides the electrical connection between the upright vacuum cleaner 10 and the electrical conductors 56, 58, 60 of the hose 44. A connector 65 at the other end of the stretch hose 44 provides secure threaded or friction fit connection with the end of the wand 42. Additional details relating to electrified stretch hoses 44 of the type incorporated into the present invention may be gleaned from reviewing various prior art references including, for example, U.S. Pat. No. 5,555,915 to Kanao.

[0025] As illustrated in FIG. 2, the wand 42 includes a first section 66 and a second section 68. In the illustrated embodiment, the two sections 62, 68 are telescoping. More

specifically, the wand **42** may be extended or retracted by depressing the actuator **70**. Once the wand **42** is extended or retracted to the desired length the actuator **70** is released to lock the wand in the desired position. The wand **42** may also include a control switch **71** for selectively activating and deactivating the electrical motor **86** of the powered cleaning attachment **50**. Additional details relating to such an electrified wand **42** may be gleaned from reviewing, for example, U.S. Pat. No. 6,148,474 to Ohara et al.

[0026] As illustrated in the partially broken away section of the drawing figure, the wand **42**, like the stretch hose **44** includes a first insulated electrical conductor **72**, a second insulated electrical conductor **74** and a third insulated electrical conductor **76**. A two-section junction box or plug **78**, identical to the junction box **64**, bridges the connector **65** and the wand section **66** to provide electrical connection between the first insulated electrical conductors **56** and **72**, the second insulated electrical conductors **58** and **74**, and the third insulated electrical conductors **60** and **76**.

[0027] As further illustrated in **FIG. 2**, the powered cleaning attachment **50** includes a housing **80**. The housing **80** defines an intake opening **82**. A rotary agitator **84** is held in the housing **80** so as to extend across the intake opening **82**. The rotary agitator **84** is rotated relative to the housing **80** by means of a drive motor **86**. More specifically the drive motor **86** has a drive shaft connected to a pulley **88** which is connected by means of the drive belt **90** to a second pulley **92** that is connected to the rotary agitator **84**. Of course, in the alternative embodiment a gear drive or a combination gear drive and belt drive may be provided in place of the belt and pulley drive that is illustrated in **FIG. 2**.

[0028] A junction box or cooperating plugs **94** provide electrical connection between the electrical conductors **72**, **74**, **76** of the wand **42** and the electrical leads (not shown) to the drive motor **86**. Thus, it should be appreciated that the drive motor **86** receives its power from the electrical wall outlet through the electrical power cord and internal wiring and circuitry in the nozzle and handle assemblies **14**, **20** of the upright vacuum cleaner, the junction box **64**, the conductors **54**, **56**, **60** in the stretch hose **44**, the junction box **78**, the conductors **72**, **74** and **76** in the wand **42**, the junction box **94** and the electrical conductors and wire leads leading from the junction box **94** to the electric motor.

[0029] As also illustrated in **FIG. 2** the powered cleaning attachment **50** may include a light source **96** for illuminating the area which the operator is attempting to clean with the powered cleaning attachment **50**. That light source **96** also receives its power through the wand **42** and stretch hose **44** in the same manner as described above for the agitator drive motor **86**.

[0030] While not specifically illustrated, the drive motor **86** could also drive an auxiliary booster fan in addition to the rotary agitator **84** in order to provide additional suction at the inlet **82**. Alternatively, the drive motor **86** may also simply be used to drive a booster fan instead of a rotary agitator **84** in the event such an arrangement were desired.

[0031] It should also be noted that the junction boxes **78** and **94** are identical. Further, the connector **65** will receive and hold the cleaning attachment **50**. Accordingly, the electrical or powered cleaning attachment **50** may be connected directly to the electrified stretch hose **44** if desired. Accordingly, the electrified wand **42** need not be used or even provided.

[0032] In summary, numerous benefits result from employing the concepts of the present invention. In the past rotary agitators in wand attachments for upright vacuum cleaners were all air driven by means of an impeller. While such rotary agitators may be driven at relatively high speeds to provide good scrubbing action, this is achieved at the expense of good suction power. In contrast, the powered cleaning attachment **50** of the present invention incorporates a rotary agitator that is driven by an electric motor at still higher speed and with greater power to provide still better brushing action. As an added benefit, the entire suction power of the vacuum cleaner remains available to draw dirt and debris loosened by that agitator into the vacuum cleaner. Accordingly, cleaning efficiency is greatly enhanced to a level heretofore unattainable with wand cleaning tools used on upright vacuum cleaners of previous design. Thus, the present invention represents a significant advance in the art and provides many benefits to the user.

[0033] The foregoing description of the preferred embodiment of the invention has been presented for purposes of illustration and description. It is not intended to be exhaustive or to limit the invention to the precise form disclosed. Obvious modifications or variations are possible in light of the above teachings. The embodiment was chosen and described to provide the best illustration of the principles of the invention and its practical application to thereby enable one of ordinary skill in the art to utilize the invention in various embodiments and with various modifications as are suited to the particular use contemplated. All such modifications and variations are within the scope of the invention as determined by the appended claims when interpreted in accordance with the breadth to which they are fairly, legally and equitably entitled. The drawings and preferred embodiment do not and are not intended to limit the ordinary meaning of the claims and their fair and broad interpretation in any way.

1. An upright vacuum cleaner, comprising:

a nozzle assembly including an intake opening;

a handle assembly connected to said nozzle assembly;

a suction generator carried on one of said nozzle assembly and said handle assembly;

a dirt collection vessel carried on one of said nozzle assembly and said handle assembly; and

a flexible, electrified stretch hose carried on one of said nozzle assembly and said handle assembly.

2. The upright vacuum cleaner of claim 1 further including an electrified cleaning wand wherein said electrified cleaning wand and said cooperating electrified stretch hose both include at least two insulated electrical conductors.

3. The upright vacuum cleaner of claim 2, wherein said stretch hose includes a reinforcing wire and a collapsible wall.

4. The upright vacuum cleaner of claim 1, wherein said electrified stretch hose includes three insulated electrical conductors.

5. The upright vacuum cleaner of claim 2, further including a cleaning attachment and a first connector securing said cleaning attachment to said wand.

6. The upright vacuum cleaner of claim 5, wherein said cleaning attachment includes an electrical motor that

receives electrical power through said two insulated electrical conductors in said wand and said stretch hose.

7. The upright vacuum cleaner of claim 6, wherein said cleaning attachment includes a rotary agitator, said rotary agitator being driven by said electrical motor.

8. The upright vacuum cleaner of claim 6, wherein said cleaning attachment includes a light source that receives electrical power through said two insulated electrical conductors in said wand and said stretch hose.

9. The upright vacuum cleaner of claim 6, wherein said cleaning attachment includes a booster fan, said booster fan being driven by said electrical motor.

10. The upright vacuum cleaner of claim 5, wherein said cleaning attachment includes a light source that receives electrical power through said two insulated electrical conductors in said wand and said stretch hose.

11. The upright vacuum cleaner of claim 5, further including a second connector securing said wand to said stretch hose.

12. The upright vacuum cleaner of claim 5, wherein said wand includes multiple sections.

13. The upright vacuum cleaner of claim 12, wherein said multiple sections of said wand are telescoping.

14. The upright vacuum cleaner of claim 1, further including at least one rotary agitator carried on said nozzle assembly in said intake opening.

15. The upright vacuum cleaner of claim 1, wherein said dirt collection vessel is a dirt filter bag.

16. The upright vacuum cleaner of claim 1, wherein said dirt collection vessel is a dirt cup.

17. The upright vacuum cleaner of claim 16, wherein said dirt cup is substantially cylindrical in shape and includes a tangentially directed inlet opening.

18. The upright vacuum cleaner of claim 6, further including a control switch for selectively activating and deactivating said electrical motor on said cleaning attachment.

19. The upright vacuum cleaner of claim 18, wherein said switch is carried on one of said wand, said stretch hose and said cleaning attachment.

20. A method of increasing the cleaning versatility and performance of an upright vacuum cleaner, comprising:

equipping an upright vacuum cleaner with a flexible stretch hose and a powered cleaning attachment tool that may be selectively secured to said flexible stretch hose and used for certain cleaning applications.

21. The method of claim 20 further including equipping said upright vacuum cleaner with a wand where both said flexible stretch hose and said wand include electrical conductors for powering said powered cleaning attachment.

22. The method of claim 21, further including equipping said powered cleaning attachment with a rotary agitator and cooperating rotary agitator drive motor.

23. The method of claim 21, further including equipping said powered cleaning attachment with a light source.

24. An upright vacuum cleaner, comprising:

- a housing;
- a suction generator carried on said housing;
- a dirt collector carried on said housing; and
- a flexible, electrified hose carried on said housing.

25. The upright vacuum cleaner of claim 24 further including a cleaning attachment having an electrical component powered through said flexible, electrified hose.

* * * * *