

(No Model.)

6 Sheets—Sheet 1.

F. D. HOEHL.
ALARM CLOCK.

No. 512,963.

Patented Jan. 16, 1894.

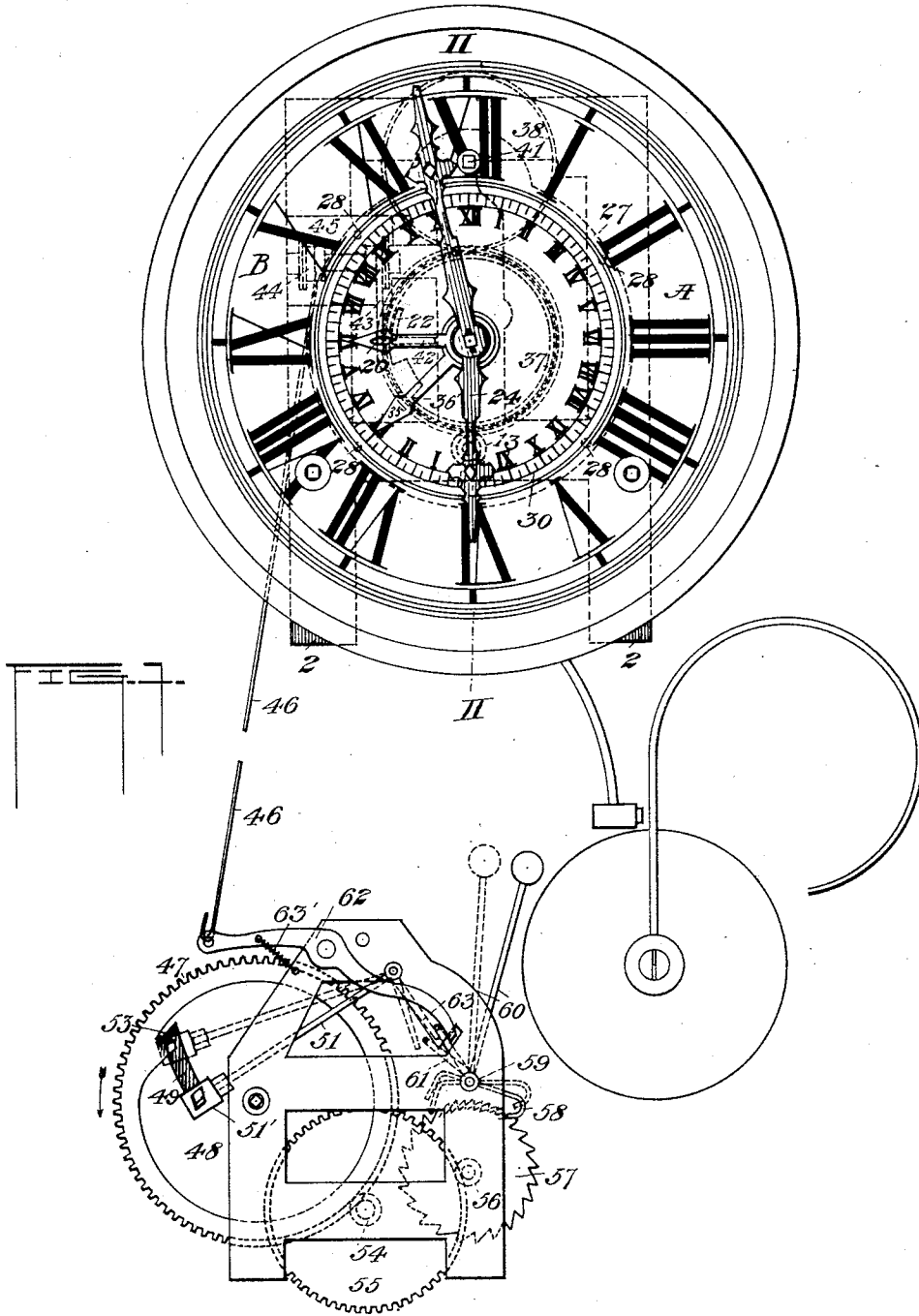

Witnesses
H. L. Gill
H. M. Corwin

Inventor
Frederick D. Hoehl
by *T. Wakewell & Sons*
his Attorneys

F. D. HOEHL.
ALARM CLOCK.

No. 512,963.

Patented Jan. 16, 1894.

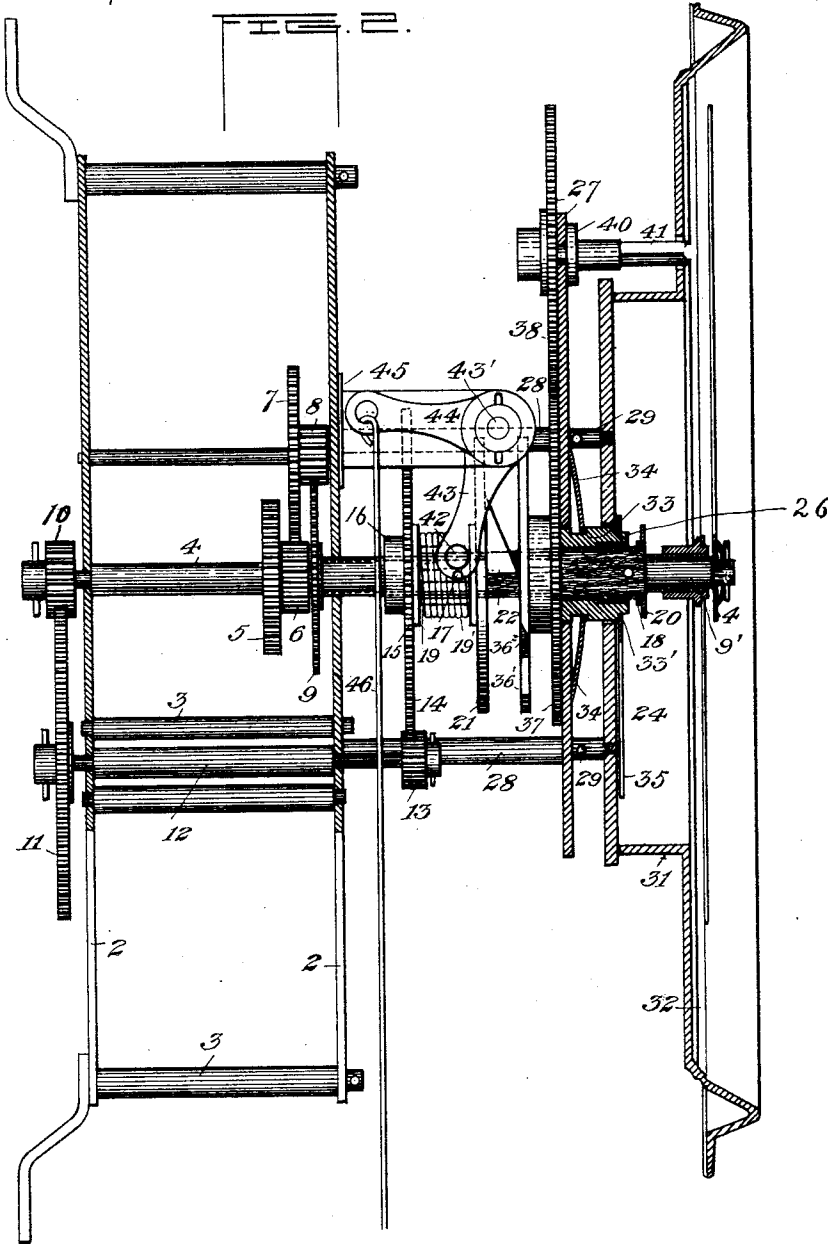

Witnesses
A. B. Gill
H. M. Corwin

Inventor
Frederick D. Hoehl
 by *T. Batewell Sons*
 his Attorneys

(No Model.)

6 Sheets—Sheet 3.

F. D. HOEHL.
ALARM CLOCK.

No. 512,963.

Patented Jan. 16, 1894.

FIG. 3.

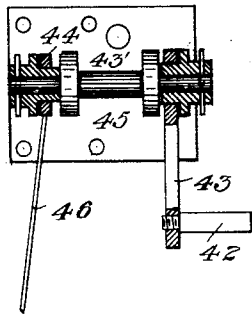

FIG. 4.

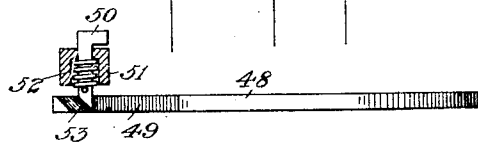

FIG. 5.

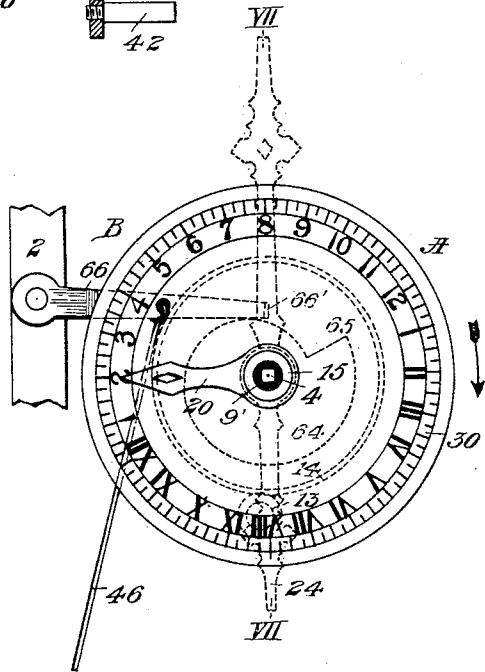
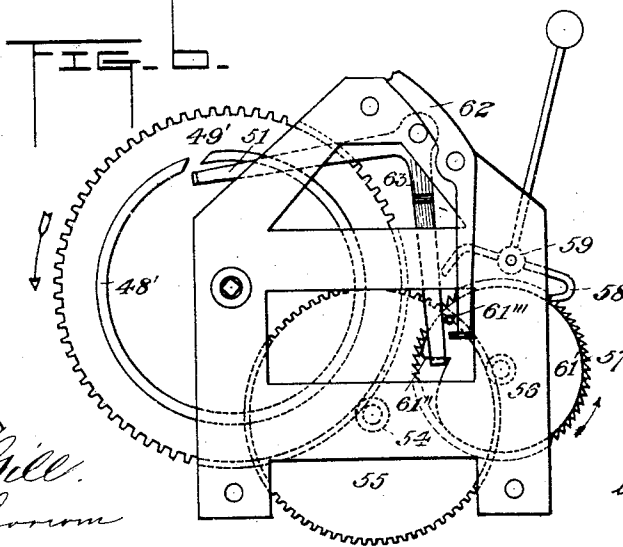

FIG. 6.



Witnesses
N. L. Gill.
H. M. Conroy

Inventor
Frederick D. Hoehl
 by *T. B. Maxwell & Sons*
 his Attorneys

F. D. HOEHL.
ALARM CLOCK.

No. 512,963.

Patented Jan. 16, 1894.

FIG. 6.

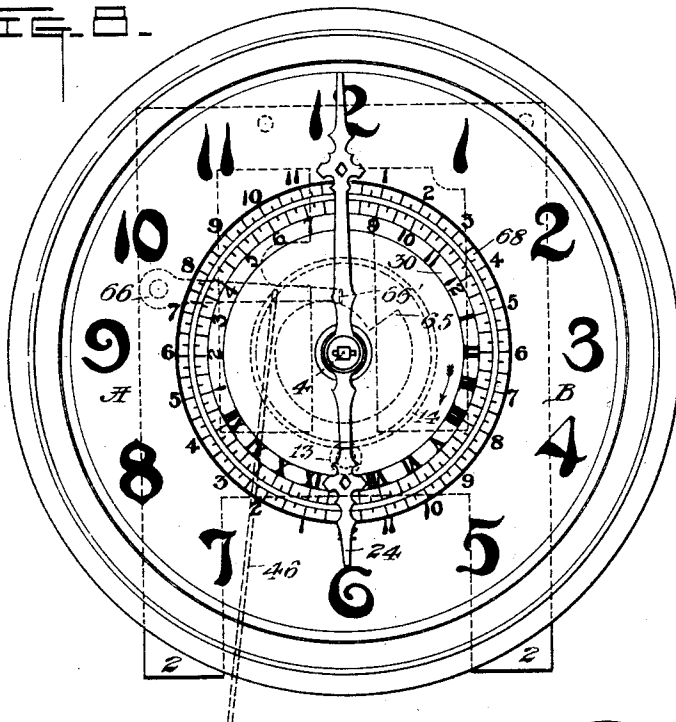

FIG. 7.

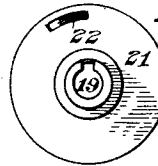

FIG. 10.

FIG. 7.

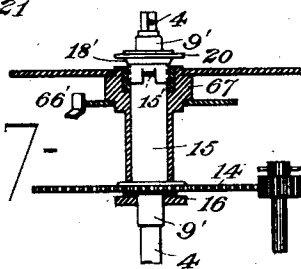

FIG. 11.

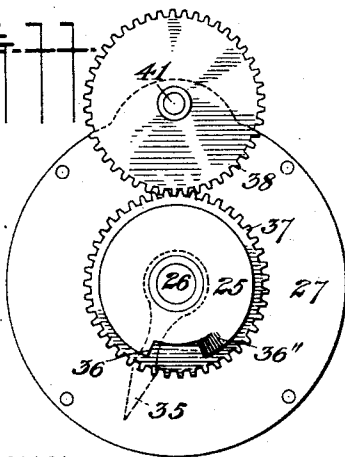
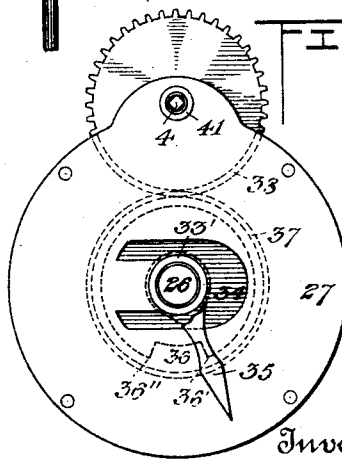

FIG. 12.



Witnesses
A. L. Gill
A. M. Corwin

Inventor
 Frederick D. Hoehl
 by *T. B. Baxwell & Sons*
 his Attorneys.

F. D. HOEHL.
ALARM CLOCK.

No. 512,963.

Patented Jan. 16, 1894.

FIG. 4.

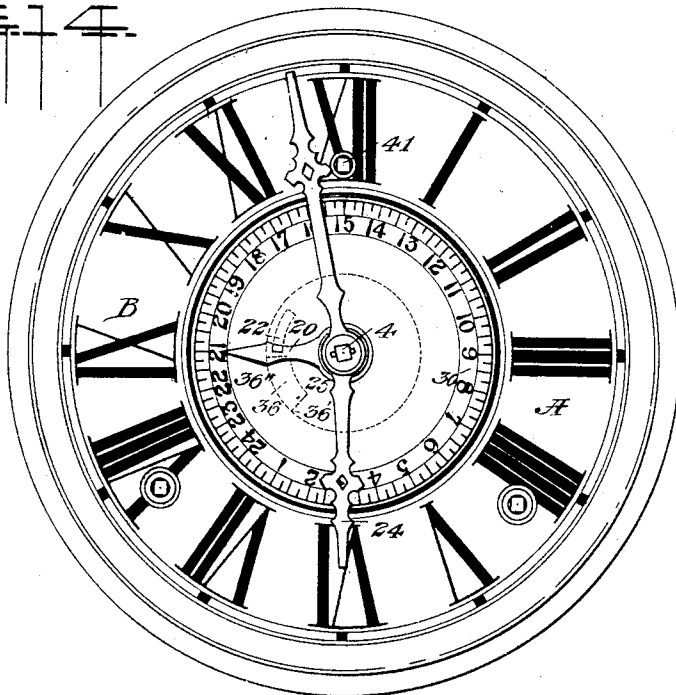
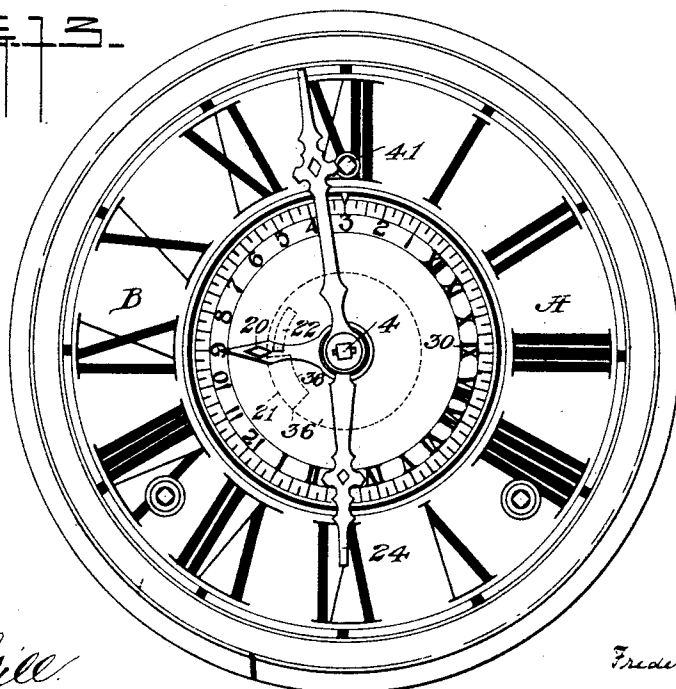

FIG. 5.



Witnesses
A. L. Gill
A. M. Conroy

Inventor
 Frederick D. Hoehl
 by *T. Bakewell, Son*
 his Attorneys.

(No Model.)

6 Sheets—Sheet 6.

F. D. HOEHL.
ALARM CLOCK.

No. 512,963.

Patented Jan. 16, 1894.

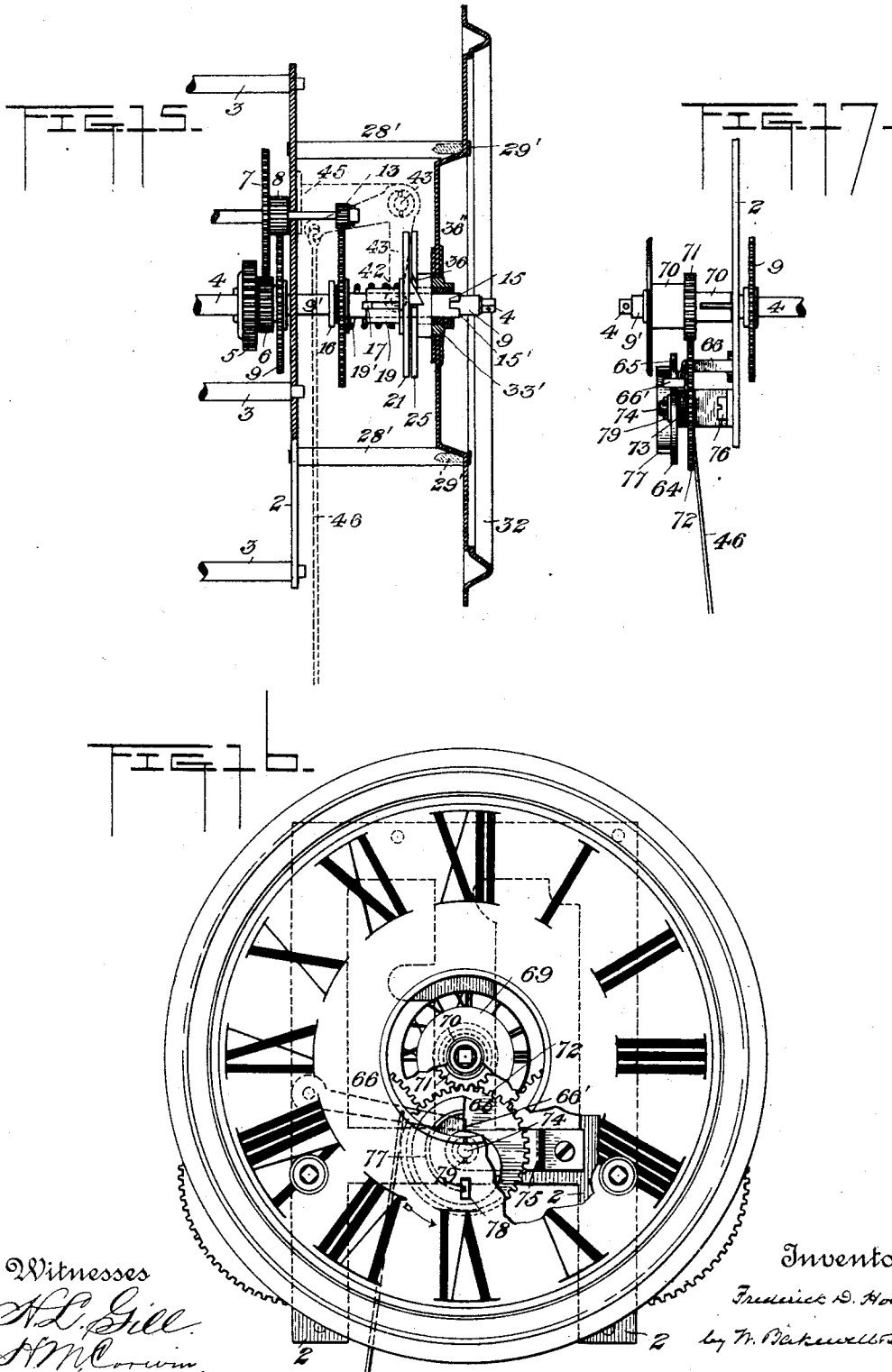

Witnesses
A. L. Gill.
A. M. Corwin.

Inventor
Frederick D. Hoehl
by *T. P. DeKewell* Attorney
his Attorneys.

UNITED STATES PATENT OFFICE.

FREDERICK D. HOEHL, OF PITTSBURG, PENNSYLVANIA.

ALARM-CLOCK.

SPECIFICATION forming part of Letters Patent No. 512,963, dated January 16, 1894.

Application filed March 31, 1892. Serial No. 427,186. (No model.)

To all whom it may concern:

Be it known that I, FREDERICK D. HOEHL, of Pittsburg, in the county of Allegheny and State of Pennsylvania, have invented a new and useful Improvement in Alarm-Clocks, of which the following is a full, clear, and exact description, reference being had to the accompanying drawings, forming part of this specification, in which—

Figure 1 is a front elevation of an alarm clock embodying my invention, the alarm movement in the lower part being shown in the position it assumes when in the act of locking and stopping the sounding of the alarm, while the alarm-controlling mechanism in the upper part is shown in an opposite position. Fig. 2 is a vertical sectional view on the line II—II of Fig. 1. Figs. 3 and 4 are detail views hereinafter referred to. Figs. 5 and 6 are views of modified forms of the alarm-controlling mechanism and alarm-movement respectively, shown in Fig. 1. Fig. 7 is a vertical sectional view on the line VII—VII of Figs. 5, and Fig. 8 is a modified form of the latter. Figs. 9, 10, 11 and 12 are views of sectional parts of the alarm-controlling mechanism shown in Figs. 1 and 2; and Figs. 13, 14, 15, 16 and 17 are views of modified forms hereinafter referred to.

Like symbols of reference indicate like parts in each of the views.

My invention relates to certain improvements upon the alarm clock, for which a patent was granted to me on January 12, 1892, No. 467,109, whereby the necessity of adding up the hours from the time of setting to the time of sounding of the alarm is dispensed with; and it consists in the improved construction and arrangement of the parts as hereinafter more fully described and set forth in the claims.

In the drawings, 2 represents the usual movement-plates joined by the pillars 3 supporting the usual clock-mechanism represented by the minute-hand arbor 4 and the wheels 5, 6, 7, 8 and 9, the latter carrying the hour-hand spindle 9'. As this mechanism is old and common I will not describe the same further.

At the rear end of the arbor 4 is secured the pinion 10 intermeshing with a toothed wheel 11, having four times as many teeth

as the pinion, and carried upon an arbor 12, which at its inner end carries a pinion 13, which meshes with a wheel 14, having six times the number of teeth of said pinion. The toothed wheel 14 is fastened to a spindle 15, which loosely encircles the hour-hand spindle 9', and is capable of rotating independently thereof. It will be seen that by means of the wheels 10, 11, 13 and 14, the wheel 14 with the spindle 15 will rotate once while the minute arbor 4 rotates twenty-four times.

A collar 16 is fastened upon the hour-hand spindle 9' to prevent the wheel 14 from interfering with the time escapement, if a pendulum is employed in front of the clock-movement. The spindle 15 extends to the face of the clock and is provided with two pins 17 and 18, which project from the spindle in the same radial plane, and enter, the one a slot in a loosely encircling sleeve 19, Figs. 9 and 10 and the other a slot in the tubular eye of the pointer 20. A disk 21, rigid with the sleeve 19, carries a cam 22, the highest point of said cam being in the same radial plane as the pins 17 and 18. It is evident as the sleeve 19, disk 21 and cam 22 are rigid, and the pin 17, which projects from the spindle 15, enters a slot in the sleeve 19, said sleeve 19 and parts fastened thereon are held in a fixed position by said pin 17 and cannot rotate unless the clock is in motion or when the clock hands are turned and consequently will rotate with the spindle 15 once in twenty-four hours, but said sleeve 19 and parts thereon may slide upon the spindle 15 from and toward the wheel 14, as said sleeve 19 fits loosely on the spindle 15 and the pin 17 holds it in place.

In order that the sleeve 19 and its attachments may slide from the wheel 14 properly, a spiral spring 19' is placed around said sleeve between its shoulder and that of the spindle 15, thus forcing said sleeve and attachments away from the wheel 14. Said wheel 14 and attached parts upon its spindle 15 rotate in the same direction as the hour-hand, and the cam 22 is provided with an incline and fastened to the disk 21, so that its highest point is in the rear, and as said point is in line with the pin 18, which enters a slot in the tubular eye of the pointer 20, said slot in the tubular eye is arranged in line with

the pointer, and thus whenever said pointer is placed upon the spindle 15, so that the pin 18 enters its slot, it will always be in line with the highest point of the cam 22 and consequently indicate its position. A collar 26 loosely surrounds the spindle 15 above the disk 21, so that it will not retard the motion of said spindle, and carries at its rear end a disk 25, which is provided with a slot 36 to receive the cam 22. A plate 27 is loosely secured to posts 28, projecting from the plate 2, by removable pins 29, and is centrally perforated to allow the passage of the neck of the collar 26, which is provided with an annular off-set 33 to receive a friction-spring 34 in front of the plate 27, and with another off-set 33' at its outer end to receive the pointer 35. Said pointer 35 is fastened to the off-set 33' in line with the edge 36' of the slot 36, which is the point at which the highest point of the cam 22 is released by the disk 25 to enter the slot, and thus said pointer 35 will always indicate the exact position of the same. It will be seen that the collar 26 and parts fastened thereto are held in position by the friction-spring 34, which tightens said collar 26 and attachments to the plate 27, but leaves it loose enough so that it may be turned by its pointer 35, or by other means, which I shall now describe.

37 is a toothed wheel which is fastened to the collar 26 immediately behind the plate 27, and meshes with a toothed wheel 38 upon a shaft 41, which is held in place by a collar 40 bearing against the plate 27, and is squared off at its outer end to receive a key, by which the collar 26 and attachments may be turned, if desired. The alarm-dial 30 is placed upon the reduced ends of the posts 28 and upon it sets the rearwardly-projecting flange 31 of the time dial 32, the latter being fastened to the frame or case.

Beneath the disk 21 and in its reciprocatory path is carried the projecting tongue 42 of a lever 43, which is fastened to a shaft 43' supported in a plate 45, this shaft 43' bearing another lever 44 connected with an alarm-lever 62 by a rod 46, as shown in Figs. 1, 2, 3 and 15.

The alarm mechanism shown at the lower part of Fig. 1, consists of a toothed wheel 47, which is driven primarily by the spring of the alarm-movement, and to the face of which is secured a stop-disk 48, this disk being provided with a slot 49 of the shape shown, into which a spring-tongue 50 carried upon an arm 51 is arranged to project, this spring-tongue being supported by a bearing 51' fastened to the arm 51 and projected by a surrounding spring 52. Shown in Fig. 4. The entrance to the slot 49 is partly closed by a beveled lip 53 upon the plate, an inwardly-curved part leading into the slot. The wheel 47 intermeshes with a pinion 54, whose shaft carries a toothed wheel 55 meshing with a pinion 56 upon the shaft of the escape-wheel

57, whereby it is rotated at a relatively high rate of speed.

58 are pallets fixed to the shaft 59, which carries the bell-clapper lever 60 and an arm 61. This arm 61 is engaged on the one side by a lever 62, which is connected with the alarm-controlling cam by the rod 46 and lever, and on the other side by an arm 63 projecting from the shaft of the arm 51.

63' is a spiral spring fastened to the movement plate and lever 62, to keep said lever in a position, as shown.

The operation of the alarm-mechanism is as follows:—When the alarm is sounded the alarm-controlling cam assumes a position, as shown in Fig. 15, the cam 22 having entered the slot 36 of the disk 25, causing its disk 21 and sleeve 19 to slide toward the disk 25, thereby allowing the lever 62 to draw on the rod 46. This will draw the lever 44 in a downward motion, and as the levers 44 and 43 are fastened to the shaft 43', the lever 43 with its tongue 42 will follow the disk 21 in the upward motion, and thus release the lever 62 from the alarm-escapement, and consequently the alarm is sounded. As the wheel 14 and its spindle 15 rotate, and the sleeve 19 and its attachments are forced along by the pin 17, and the collar 26 and its attachments are held stationary by friction, the cam 22 will slide out of the slot 36 upon the disk 25, and is gradually forced toward the wheel 14 by said disk 25. In order that the cam may slide out of said slot easily, the edge 36'' is beveled off, and after the highest point of said cam has passed said beveled edge 36'', it is forced toward the wheel 14 to its full extent and will ride thereafter smoothly on the disk 25. The downward motion of the cam and its attachments move the tongue 42 and, consequently, the lever 43 in the same direction, thus causing the arm 44 to draw the rod 46 and assume the position shown in Fig. 2. The upward motion of the rod causes the lever 62 to engage the arm 61 and said arm to engage the arm 63, thereby withdrawing the arm 51 from the slot 49, and in its motion the spring-projected tongue 50 will ride over the beveled lip 53, and after it has passed said lip it is projected by its spring 52, and thus the stop-lever is prevented from returning in the slot and leaves the alarm-movement in a position ready to sound the alarm when the cam 22 again slides from the edge 36'' into the slot 36. When the lever 62 is released by the action of the cam, the alarm will sound until the slot 49 comes again opposite to the tongue 50, when said tongue will re-enter said slot and cause the arm 63 to engage the arm 61 and thus lock the alarm-escapement.

In place of the alarm-mechanism above described, I may employ that of Fig. 6, wherein a band 48' is fastened to the wheel 47, being provided with a slot 49' to engage the arm 51, and a disk 61' is arranged upon the pinion 56,

having an off-set or catch 61'' to engage the arm 63, the stop-lever being thus held out of action by the band 48' until the slot 49' arrives opposite the end of the arm 51, when said arm is allowed to enter the same, which will bring the arm 63 upon the disk 61' and drop into the catch 61'' and thus lock the alarm-escapement. A pin 61''' is fastened to the disk 61', and the lever 62 is arranged to move the arm 63 out of the catch 61'' and receive the said pin 61''' and thus lock the alarm-escapement until said lever 62 is released by the action of the cam 22, when said lever is withdrawn from the pin and the escapement is free to sound the alarm.

The adjustment of the alarm-controlling mechanism is as follows: Having placed the alarm-dial 30, which is provided with two sets of general divisions, upon the posts 28 as shown, and adjusted the pointers 20 and 35 with their respective parts as before described, the pointer 35, which represents the point at which the alarm shall sound, may be set opposite any desired division of the two sets, and consequently the alarm may be set for any desired hour indicated by the hour-hand. Now, in order that the alarm may sound at the hour desired, the pointer 20, which represents the cam 22, is placed in a certain relative position to the divisions of the alarm-setting dial and hour-hand respectively, and consequently will arrive with its cam in due time opposite the pointer 35 to allow the cam to drop into the slot 36 and sound the alarm. Thus in Fig. 1, the time is six o'clock, as shown, which is represented by the pointer 20 in a position equivalent to the division 6 of the alarm-setting dial, shown on side B, and the pointer 35 is set opposite the division 3, on the same side of the pointer 20. Now as the pointer 20 with its cam must rotate from the division 6 on the side B, to the division 3 on the same side, a period of twenty-one hours, it is evident that the hour-hand may indicate either a. m. or p. m., the alarm being set accordingly. If the time indicated is six a. m., the alarm is set for three a. m.; if six p. m. for three p. m., and if said pointer 20 were on the side A, and the pointer 35 set opposite the division 3 on the same side, the condition would be the same. It is evident that on whichever side the pointer 20 may be, the set of divisions on the same side of the pointer always indicates either a. m. or p. m., according as the time of the day may be, and the set of divisions on the other side and the pointer 35 may be set accordingly. If, however, each set shall have always the same distinctive mark, the mechanism may be adjusted so that the time may be a. m. when the pointer 20 is on the side A, and p. m. when said pointer is on the side B, as may be desired.

I do not intend to limit myself to any specific form, but may employ any modified form which comes fairly within the spirit and scope of my invention. Thus in Fig. 5 I show

a simple form of the alarm-controlling mechanism, of which Fig. 7 is a vertical sectional view. It consists of a cam-disk 64 having an offset 65, and is fastened to a sleeve 67, said sleeve 67 fitting tightly on the spindle 15, but is loose enough so it may be turned when desired by the dial-plate 30, which is fastened to its outer end. It is evident that the cam-disk 64 and the dial-plate 30 are rigid with the sleeve 67, and are consequently rotated by the spindle 15 once in twenty-four hours in the direction of the arrow. The pins 17 and 18, which project from the spindle 15 in Fig. 2, are omitted in this form, as the sleeve 67 with its attachment is rotated by means of friction, as above described, and in place of the pin 18, the spindle 15 is provided with a slot 15', as shown in Fig. 15, and a small part of the tubular eye of the pointer is bent inwardly, forming a pin. Thus when the pointer 20 is placed upon the spindle 15, the pin 18' will enter the slot 15' and hold said pointer in a fixed position in relation to the spindle 15, so that it cannot be moved from its respective position after it has been adjusted with its relative parts, but rotates with the said spindle in a fixed position once in twenty-four hours.

66 is a lever pivoted to the movement-plate 2 and having at its end a tongue 66', which rides upon the periphery of the cam-disk 64 and drops into its offset 65 whenever the latter comes opposite to said tongue, and thus releases the alarm-mechanism and sounds the alarm. It is evident that as the lever 66 is held in a fixed position and is only allowed to be raised by the periphery of the cam-disk 64, and drops into the off-set 65, said off-set 65 will always release the lever-tongue 66' at the same point, and as the cam-disk rotates once in twenty-four hours, its off-set 65 will consequently require the same time from the time it leaves to the time it arrives opposite the said tongue, and therefore the alarm is sounded but once.

The alarm-setting dial is provided with two sets of general divisions as before, which are distinguished by design, one set being numbered in the Roman, and one in the Arabic form, in order that when the alarm is to be set, the relative parts may be easily adjusted as hereinafter described. The pointer 20, which is fixed to the spindle 15 of the wheel 14 and rotates therewith once in twenty-four hours, is placed in a certain relative position to the equivalent divisions of the hour-hand and the alarm-setting dial, as indicated by the hour-hand and as assumed by the alarm-setting dial when the offset 65 of the cam-disk 64 is opposite to the lever-tongue 66' respectively, and thus when the alarm is set for any desired division or hour, by means of said pointer, the respective division will rotate with the pointer to the place it always assumes when the offset 65 of the cam-disk 64 is opposite the lever-tongue 66', and as the pointer and hour-hand stand always in

the same relative position, said division and pointer, and, consequently, the off-set 65, will assume their respective positions in proper time to sound the alarm.

5 In Fig. 5 the alarm-setting dial is fastened to the sleeve 67, so that the division 12 of the Arabic set in line with the off-set 65 of the cam-disk 64, and therefore said division and off-set will be opposite the lever-tongue 66' at the same time; and when in said position, it will be seen that the Roman set would be on the side A, and the Arabic set on the side B, and if the pointer 20 be placed upon its spindle 15 in its respective position, it would point to a certain division of the alarm-setting dial, and thus said pointer would be in the same position as the respective division of the alarm-setting dial assumes whenever the off-set 65 of the cam-disk 64 is opposite the lever-tongue 66', and consequently whenever the alarm is sounded, in order that the respective division thus indicated by the pointer 20 may correspond with the division of the hour-hand, said hour-hand is placed upon its spindle to point to the same respective division as indicated by the pointer, and thus the parts are adjusted to sound the alarm at the proper time. Having the parts thus adjusted, at six o'clock the pointer 20 would be in the position that the division 6 of the alarm-setting dial assumes when the off-set 65 is opposite the lever-tongue 66', which is shown in Fig. 5 on the side B, but may be on either side. If the division 2 of the Arabic set, which according to the above adjustment is always on the side B when the off-set 65 is opposite the lever-tongue 66', is then set opposite the pointer 20, it is evident that said division must move with the pointer in the direction of the arrow until they arrive in the position the division 2 of the Arabic set assumes when the off-set 65 is opposite the lever-tongue 66', which will require twenty hours, and thus the time indicated by the hour hand may be either a. m. or p. m., the alarm being set accordingly; and if the pointer 20 were on the side A, and the division 2 of the Roman set opposite the pointer, the condition would be the same. It is evident that as long as the pointer 20 is on the side A, the Roman set may indicate a. m. or p. m., according to the time of the day, and the Arabic set the opposite, and as long as the pointer is on the side B, the Arabic set may indicate a. m. or p. m., according to the time of day, and the Roman set the opposite. If, however, each set shall have its distinctive mark, the mechanism may be adjusted so that when the time is a. m., the pointer 20 is on the side A, and thus the Roman set would indicate a. m., and when p. m., the pointer is on the side B, and thus the Arabic set would indicate p. m., whichever may be desired.

Fig. 8 is a modification of the form of Fig. 5, the pointer 20 being omitted, and in its place a dial 68 employed with two sets of general divisions surrounding the alarm-setting

dial 30, to set the alarm in the same manner as described above. It is however evident that if the alarm-setting dial shall have its reverse mark for its sets of divisions, one set of divisions of the dial 68, no matter on which side, is sufficient by which to set the alarm.

In Fig. 13 I show the same mechanism as in the upper part of Fig. 1, except that the alarm-setting dial is fastened to the off-set 33' of the collar 26, and therefore moves when the collar 26 and its attachment are turned, and the pointer 35 is stationary in the flange 31 of the time-dial. As the dial moves, its divisions are distinguished in a manner described before, and when the alarm is set, the desired division is set opposite the pointer 35. It will be seen that the Arabic division 12 is placed in line with the point 36' of the slot 36 arranged upon the disk 25, and if the dial is turned so that said division is opposite the pointer 35, the Arabic set is on the side A, and the Roman on the side B, and the division 6 will come opposite the pointer 20 with its cam 22, and thus said pointer may retain its position as in Fig. 1. Thus adjusted, the Arabic set indicates a. m. and p. m. as long as the pointer 20 is on the side B, according to the time of the day as explained before, and the Roman set the opposite, and when the pointer is on the side A the Roman set indicates a. m. and p. m. and the Arabic set the opposite. If the time were six p. m., the alarm would be set for three p. m. the next day as indicated by the pointer 35, and if the time were six a. m., the alarm would be set for three a. m., the position being the same.

The mechanism in Fig. 14 is similar to that shown in Fig. 13. The alarm-setting dial is carried by the collar 26, and by means of the design of the divisions as shown, the pointer 35 is omitted and the alarm is set by means of the pointer 20. By adding up the hours from the time of setting to the time of sounding the alarm, and setting the respective number opposite the pointer 20, no matter in what position said pointer and hour-hand may be, the alarm is just as accurately set as in the other forms, but as the other forms are much more simple, I will not describe the same further.

In Fig. 15, the pinion 13 is fastened to the shaft of the intermediate wheels 7 and 8 and rotates therewith eight times in twenty-four hours, and, consequently, the wheel 14 is eight times the size of said pinion, in order that it may rotate but once in the same time. The time-dial 32 is secured to posts 28' by screws 29' and surrounds the neck of the collar 26 and forms a bearing for said collar and attachments, and thus the plate 27 may be omitted and the off-set 33' may either receive the dial 30, or pointer 35, whichever may be desired.

In Fig. 16, I show a modified form of the alarm-controlling mechanism, shown in Figs. 5, 7 and 8, of which Fig. 17 is a sectional view. It consists of an ordinary alarm-setting dial 69,

as shown, fastened to a sleeve 70, which carries in the rear a wheel 71, and is carried upon the hour-hand spindle 9' frictionally, or the same as in an ordinary alarm clock and consequently rotates with said attachment with the hour-hand spindle twice in twenty-four hours. The wheel 71 meshes with a wheel 72, which is twice the size of said wheel 71 and is fastened to a sleeve 73, arranged loosely upon a projection 74, which is fastened to a bearing 75, secured to the movement-plate 2 by means of a screw 76. To the outer end of said sleeve 73 is secured the cam-disk 64, upon which rides the lever-tongue 66' as before, and to which is secured a circular-shaped band 77, covering one-half of said cam-disk 64, and is colored on its face and passes underneath a slot 78, arranged upon the time-dial as shown, and in front of said sleeve, through the projection 74, passes a pin 79, to keep said sleeve and attachments in position. As the wheel 72 is twice the size of the wheel 71, which is rotated with its sleeve 70 and dial 69 by the hour-hand spindle twice in twenty-four hours, said wheel 72 and, consequently, its attachments rotate but once in the same time, and thus the relative mechanism between the off-set 65 of the cam-disk 64 and the lever-tongue 66' is the same as that described in Fig. 5. The band 77 is an indicator by which the position of the cam may be known at a glance, and the alarm-setting dial may be adjusted as easily as in an ordinary alarm-clock. Thus having adjusted the relative parts as shown, which is the position said parts assume whenever the alarm is sounded, the position of the hour-hand 24, and the appearance of the band 77 in the slot 78, indicate that the alarm was just sounded at 3 o'clock, and in the first cycle of the dial 69 the band 77 will always be in view, thus indicating that if any division of said dial is set opposite the hour-hand 24, the alarm will not sound within the cycle of the hour-hand, but will sound at the respective hour after the first cycle. After the first cycle of said dial 69, the band will disappear, and thus it is known that if any division of said dial is set opposite the hour-hand, the alarm will sound at that hour within the cycle of the hour-hand.

Other forms will readily suggest themselves to those skilled in the art.

The advantages of my improvement are obvious. The alarm may be set to operate once in twenty-four hours, while no computation is necessary, the alarm-setting dial being adjusted or set as in an ordinary alarm-clock.

I claim as my invention—

1. In a clock, the combination with the clock-movement geared to complete one cycle of motion in twelve hours, of an alarm-movement, a cam controlling the alarm-movement, connections between the cam and clock movement constructed and arranged to set off the cam once in twenty-four hours, an alarm-setting dial having divisions, and a movable indicator arranged to indicate the position of the cam; substantially as and for the purposes described.

2. In a clock, the combination with the clock-movement geared to complete one cycle of motion in twelve hours, of an alarm-movement, a cam arranged to revolve once in twenty-four hours and controlling the alarm-movement, an alarm-setting dial fixed to the cam and having twenty-four divisions, and a movable indicator arranged to revolve once in twenty-four hours; substantially as and for the purposes described.

3. The combination with the alarm-movement, of a stop-lever, a rotary disk having one or more stops arranged to cooperate with said stop-lever to lock the alarm-movement, and a cam mechanically connected with the alarm-movement and operated by the clock-movement to lock said alarm-movement and move the stop-lever over the stop into disengagement; substantially as and for the purposes described.

4. The combination with the alarm-movement, of a stop-lever, a rotary disk having its periphery provided with one or more slots or set-offs to hold said stop-lever out of the path of the stop and admit the same into the slot or set-off to engage the stop and lock the alarm-movement, means arranged to prevent the stop-lever from returning into the path of the stop when it is disengaged, and a cam mechanically connected with the alarm-movement and operated by the clock-movement to lock the alarm-movement and disengage the stop-lever; substantially as and for the purposes described.

5. The combination with the alarm-movement, of a stop-lever arranged to lock the same, a stop arranged upon a rotary disk, and a cam mechanically connected with said stop and operated by the clock-movement to lock the alarm-movement and free the stop-lever; substantially as and for the purposes described.

In testimony whereof I have hereunto set my hand this 18th day of February, A. D. 1892.

FREDERICK D. HOEHL.

Witnesses:

T. W. BAKEWELL,
W. B. CORWIN.