



Office de la Propriété
Intellectuelle
du Canada

Un organisme
d'Industrie Canada

Canadian
Intellectual Property
Office

An agency of
Industry Canada

CA 2404372 A1 2004/03/30

(21) **2 404 372**

(12) **DEMANDE DE BREVET CANADIEN
CANADIAN PATENT APPLICATION**

(13) **A1**

(22) Date de dépôt/Filing Date: 2002/09/30
(41) Mise à la disp. pub./Open to Public Insp.: 2004/03/30

(51) Cl.Int.⁷/Int.Cl.⁷ B62B 1/18
(71) Demandeur/Applicant:
SLEVINSKY, PAUL, CA
(72) Inventeur/Inventor:
SLEVINSKY, PAUL, CA

(54) Titre : BROUETTE PERFECTIONNEE
(54) Title: THE NEW CONTROL-A-BARROW



DESCRIPTION OF INVENTION:

Many novel and innovative ideas have been incorporated in this new wheelbarrow. The wheelbarrow was designed with safety, function and ergonomics in mind. Most wheelbarrows currently on the market use archaic design principals. The machines tend to be unstable and difficult to control when moving loads or when dumping loads. The wheelbarrow described in this document improves the balance and stability of a wheelbarrow. Many safety features not found on other wheelbarrows are designed-in to the device described in this document. Such features include:

- automatic wheel brakes that are applied when the wheelbarrow is at rest
 - pivotally linked tub and base structures with tub mounted handles and base mounted wheels
 - dual wheel base with limited side to side rocking movement for stability when moving over uneven terrain
 - Floating latch mechanism that allows limited side to side rocking movement between the base and tub for stability when moving over uneven terrain while engaged.
 - Multi-link tub support bars that generate a high pivoting center at or near the load-center for stability and easy handling when moving or when dumping.
 - Multi-funneled tub shape and large displacement angles between the base and tub that allows accurate front or side dumping with ease and stability.
 - Ergonomic handle-bar shapes mounted to the wheelbarrow tub that facilitate large tub displacement angles while maintaining natural and comfortable wrist/arm movement and secure grip.
-

- Intuitive Hand or foot operated latch release mechanism that allows large displacement angles between the base and tub for dumping when released.
- Retractable debris bag holder that deploys to support the open mouth of a leaf or garden bag between the wheelbarrow handlebars. The closed end of the bag can rest, self-supported, on the ground.

COMPONENTS

Tub structure:

The tub structure consists of the tub, the handlebars and the attach points to pivotally mount the multi-link tub support bars.

Base structure:

The base structure consists of the base, the wheels and the attach points to pivotally mount the multi-link tub support bars.

Multi-Link tub support bars:

Multi-link tub support bars consist of a main pivot arm rotatably axle-mounted common with the wheels, and two drag links that are rotatably mounted to a second axle behind the wheels. The main pivot arm projects from the forward axle toward the rear pivot attachment point on the underside of the tub. The drag links project from the rear axle to the forward pivot attachment points on the upward sloping front underside of the tub. Three swivel attachments connect the wheelbarrow tub to the multi-link support bars. The rear tub attachment is located on the centerline below the tub. The front two swivel attachments are located parallel each other on the underside of the forward sloping surface of the tub. The main pivot arm and the drag links rotate in unison as a four-bar link to allow the wheelbarrow tub a high forward tilt angle with minimum vertical displacement of the load's mass center. This arrangement also allows the tub to achieve sufficient dumping angle without over-centering the load's mass beyond the wheels, which can cause an unstable situation. The drag links each have a second plane of rotation that allows side to side tilting of the wheelbarrow tub. The tub rotates about the rear tub attachment and about a false center described by the drag links acting as a four-bar link in the side to side plane of rotation. The Wheelbarrow tub has a reduced side to side tilt angle relative the base when the latch mechanism is engaged. The drag links have contact points that strike the main pivot arm and limit the tub's side to side tilt when the latch mechanism is engaged. The drag links also have contact points that project toward the wheels from below the rear axle. Those contact points serve as wheel brakes when the wheelbarrow is at rest or when the handles are released. The drag links rotate about the rear axle enough to disengage the

wheel brakes from the wheels when the wheelbarrow handles are raised sufficiently to cause the latch mechanism to engage. The drag links cross by each other to support opposite sides of the tub. At the point where they pass adjacent each other, matching slots in each drag link allows for a bolt and spacer assembly to ensure proper alignment of the drag links while also limiting excessive travel or side to side displacement of the tub.

Latch Mechanism:

The Latch mechanism is a device that is mounted either on the main pivot arm and engages the rear axle or on the rear axle and engages the main pivot arm. The latch mechanism can be activated by either a hand lever similar to a bicycle brake or by a foot-operated lever. The activating method can either be direct or indirect via a wire cable and sheath or other linkage system.

Ergonomic Handlebars:

The Ergonomic Handlebars project rearward from the tub. The handle grip portions of the bars have a bend at mid point. The extreme ends of the handle bars project down and outward each at 30-degree angle displacement from both horizontal and parallel planes.

Automatic Wheel Brakes:

The drag links have contact points that project toward the wheels from below the rear axle. Those contact points serve as wheel brakes when the wheelbarrow is at rest or when the handles are released. The drag links rotate about the rear axle enough to disengage the wheel brakes from the wheels when the wheelbarrow handles are raised sufficiently to cause the latch mechanism to engage.

Retractable Debris Bag Holder:

The Retractable Debris Bag Holder deploys to support the open mouth of a leaf or garden bag between the wheelbarrow handlebars. The mechanism stows in the rolled upper rim of the wheelbarrow tub when not in use.

DRAWING REFERENCES

1. Automatic Wheel Brakes
2. Multi-funneled Tub
3. Tub Mounted Ergonomic Handle-bars
4. Hand Operated Latch Release Mechanism
5. Dual Wheel Base
6. Wheels
7. Main Pivot Arm
8. Drag Links
9. Floating Latch
10. Multi-link Tub Support Bars
11. Retractable Debris Bag Holder

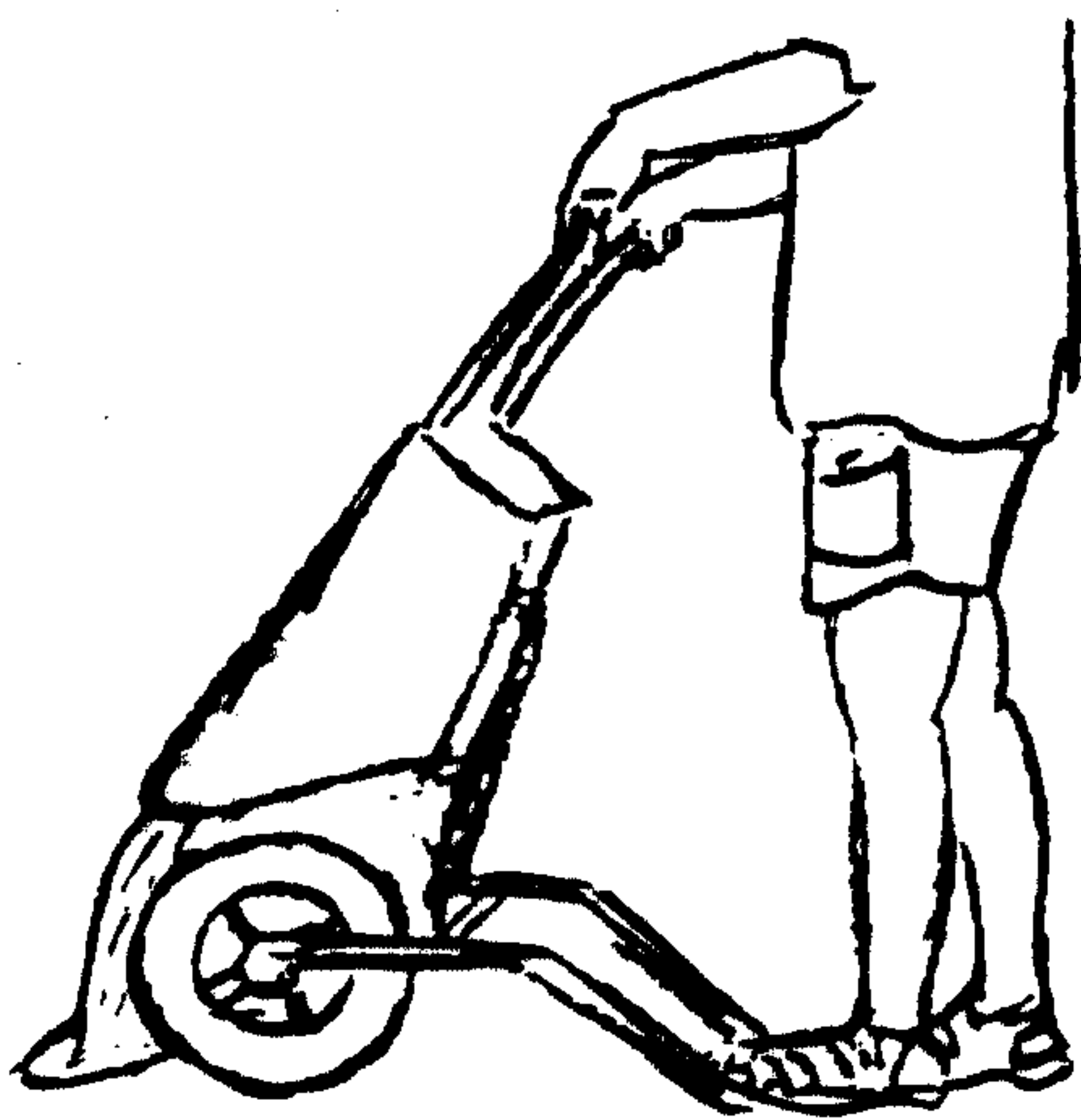
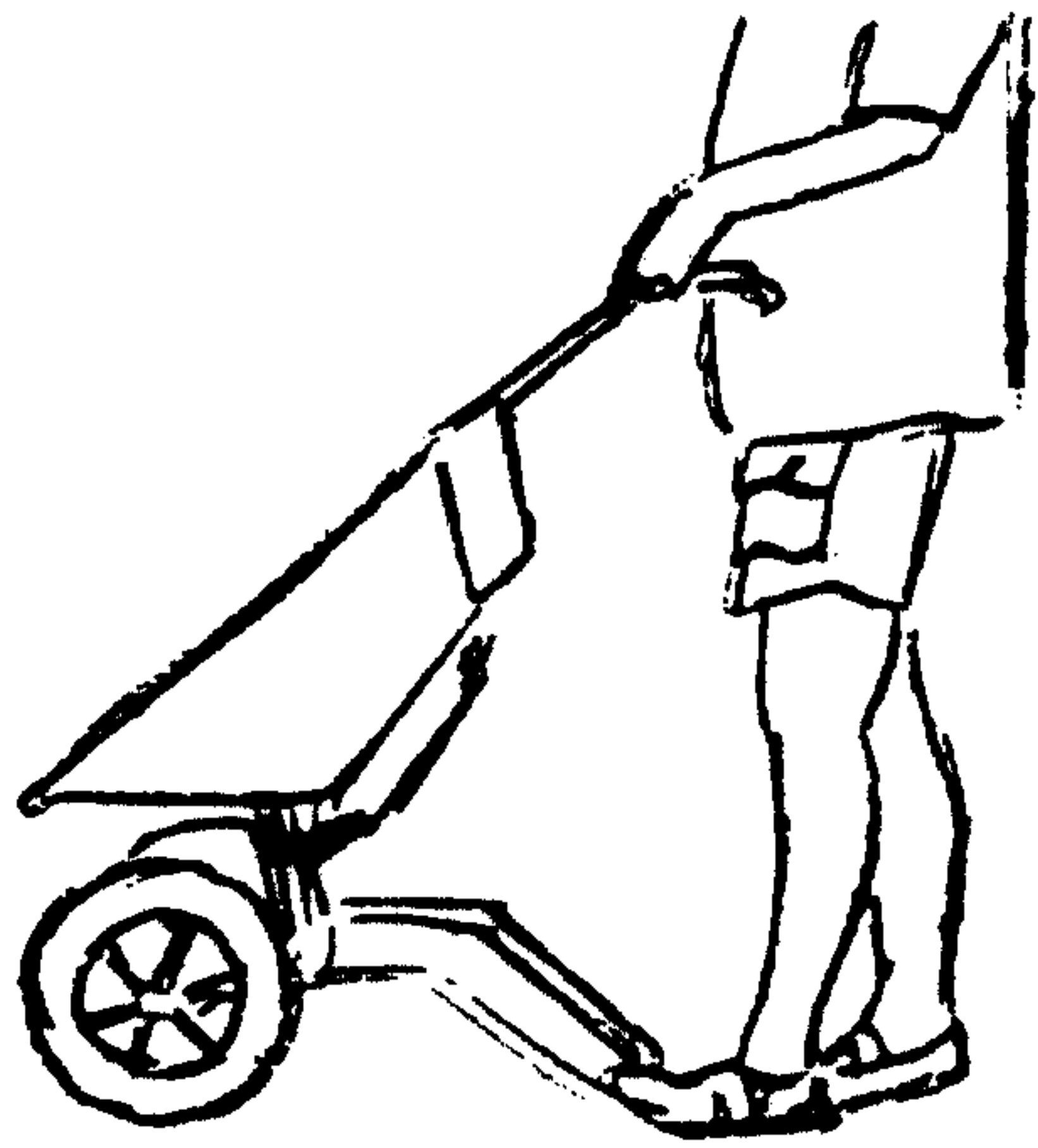
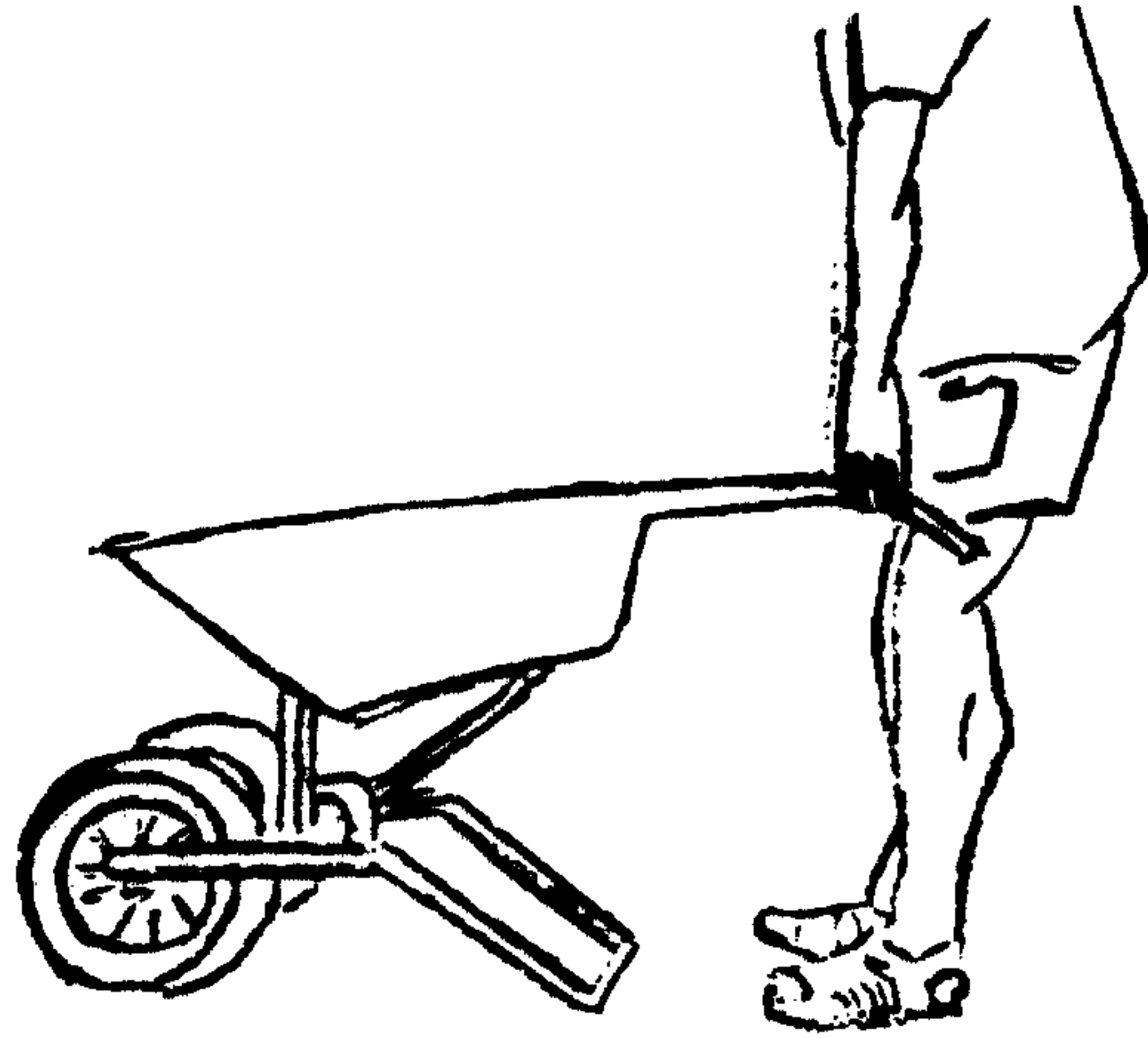

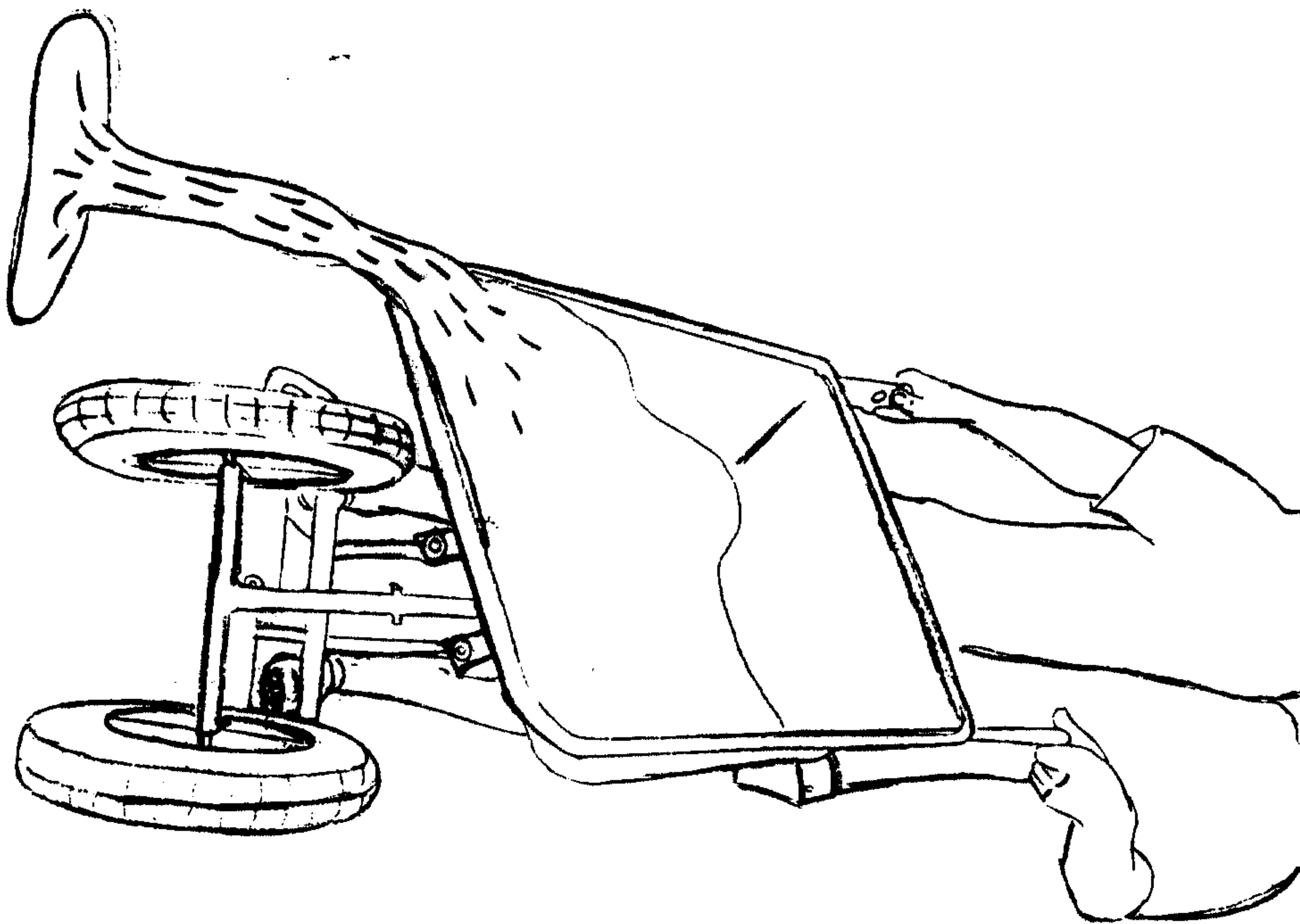
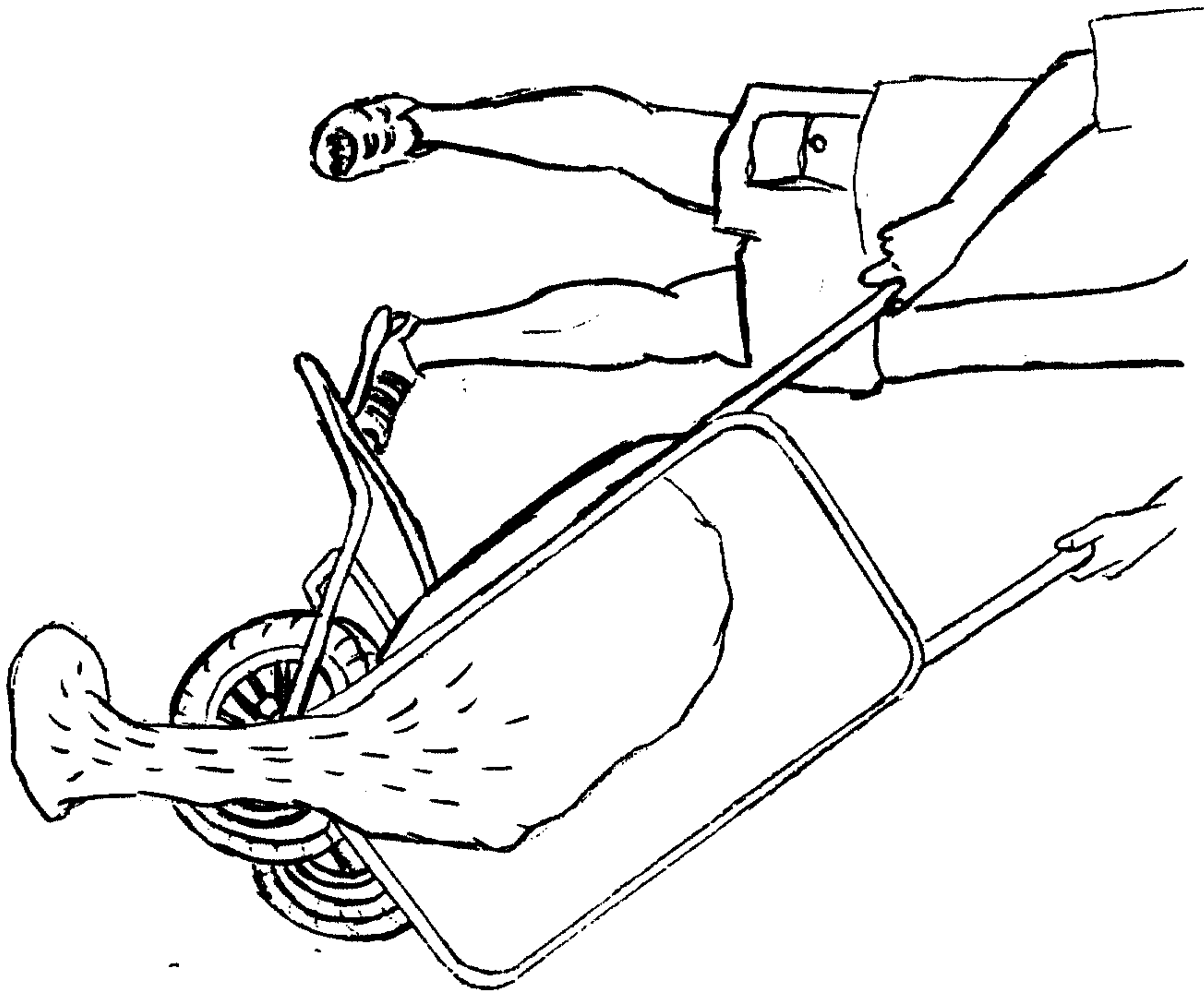

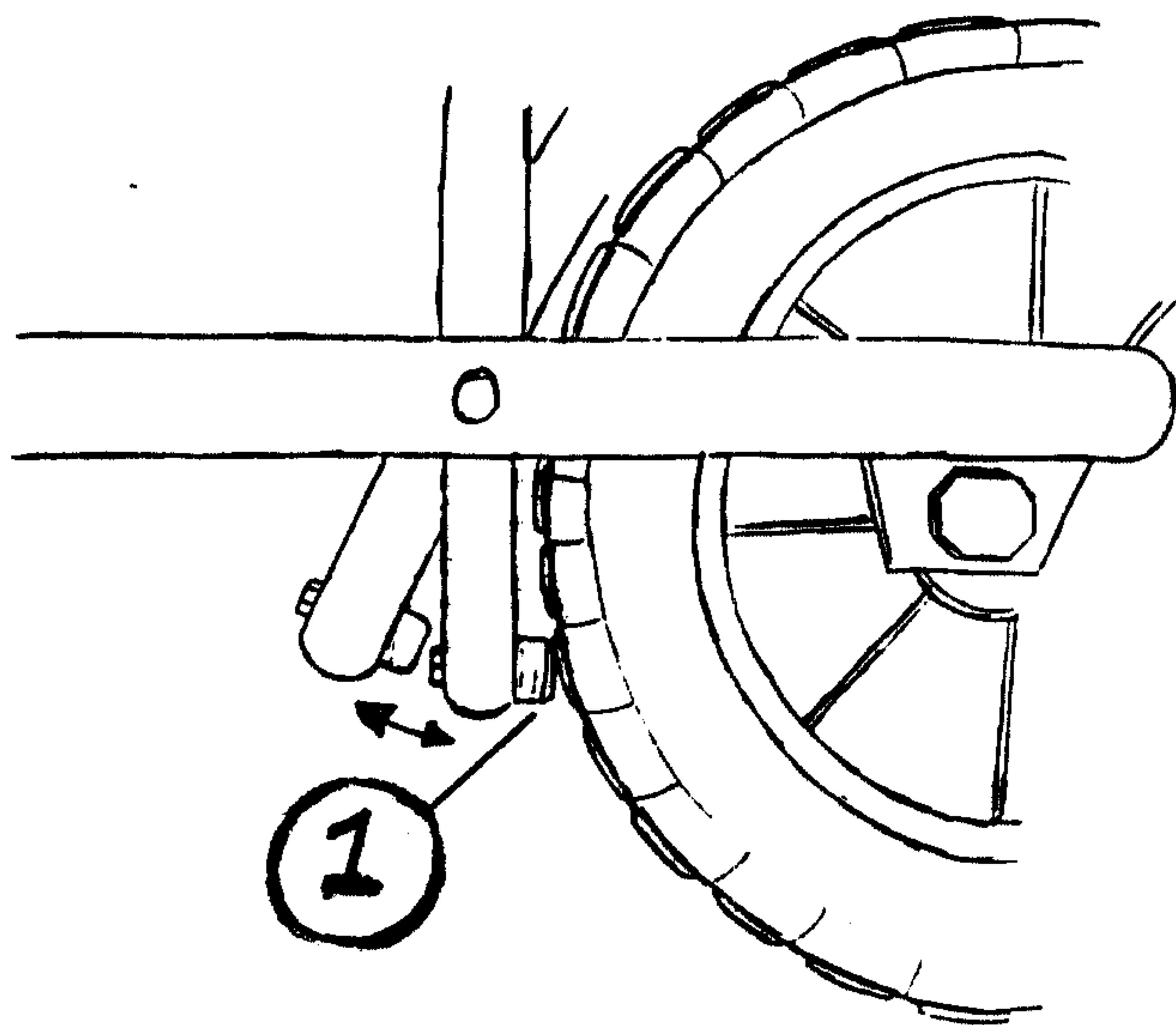
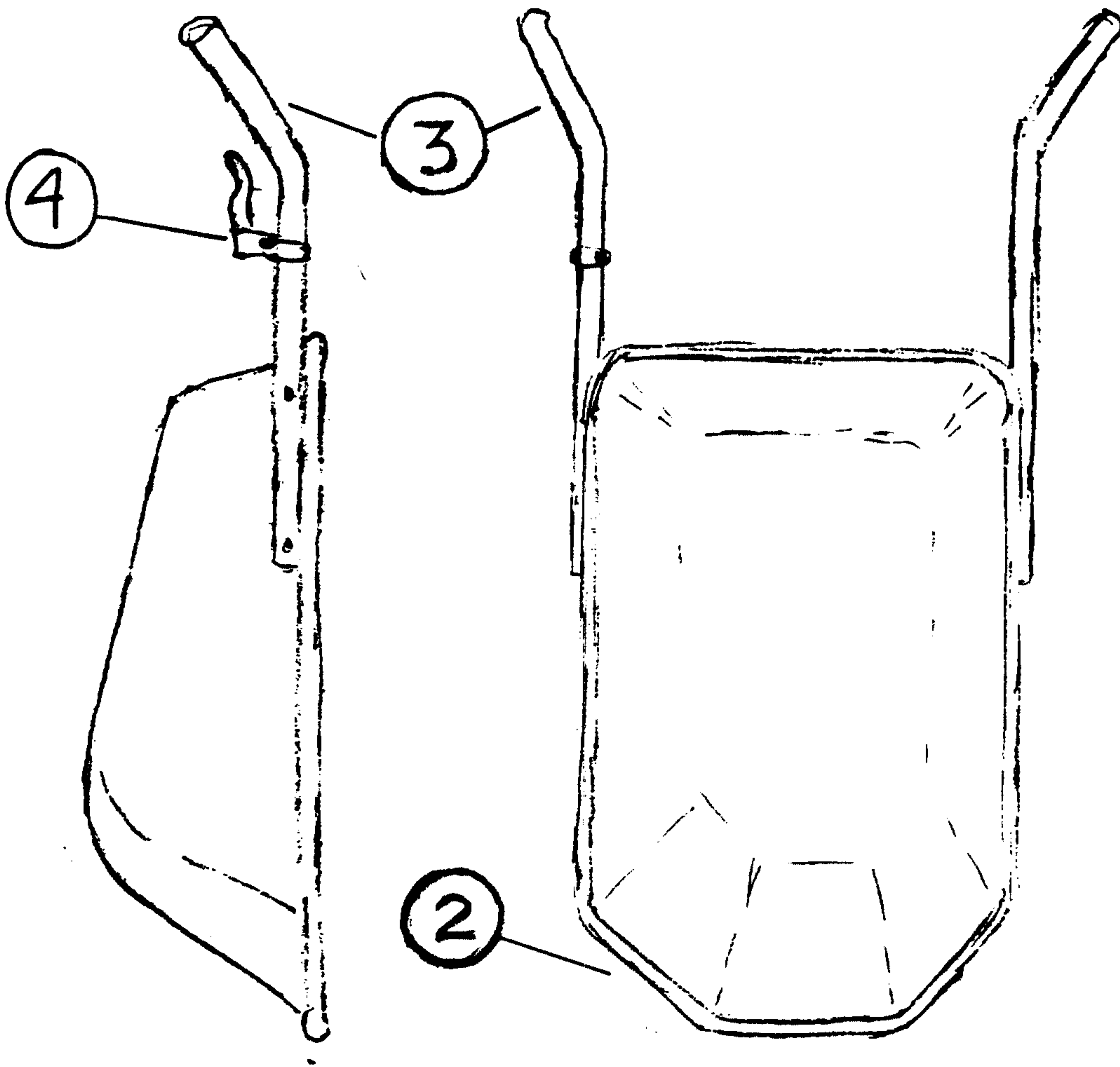

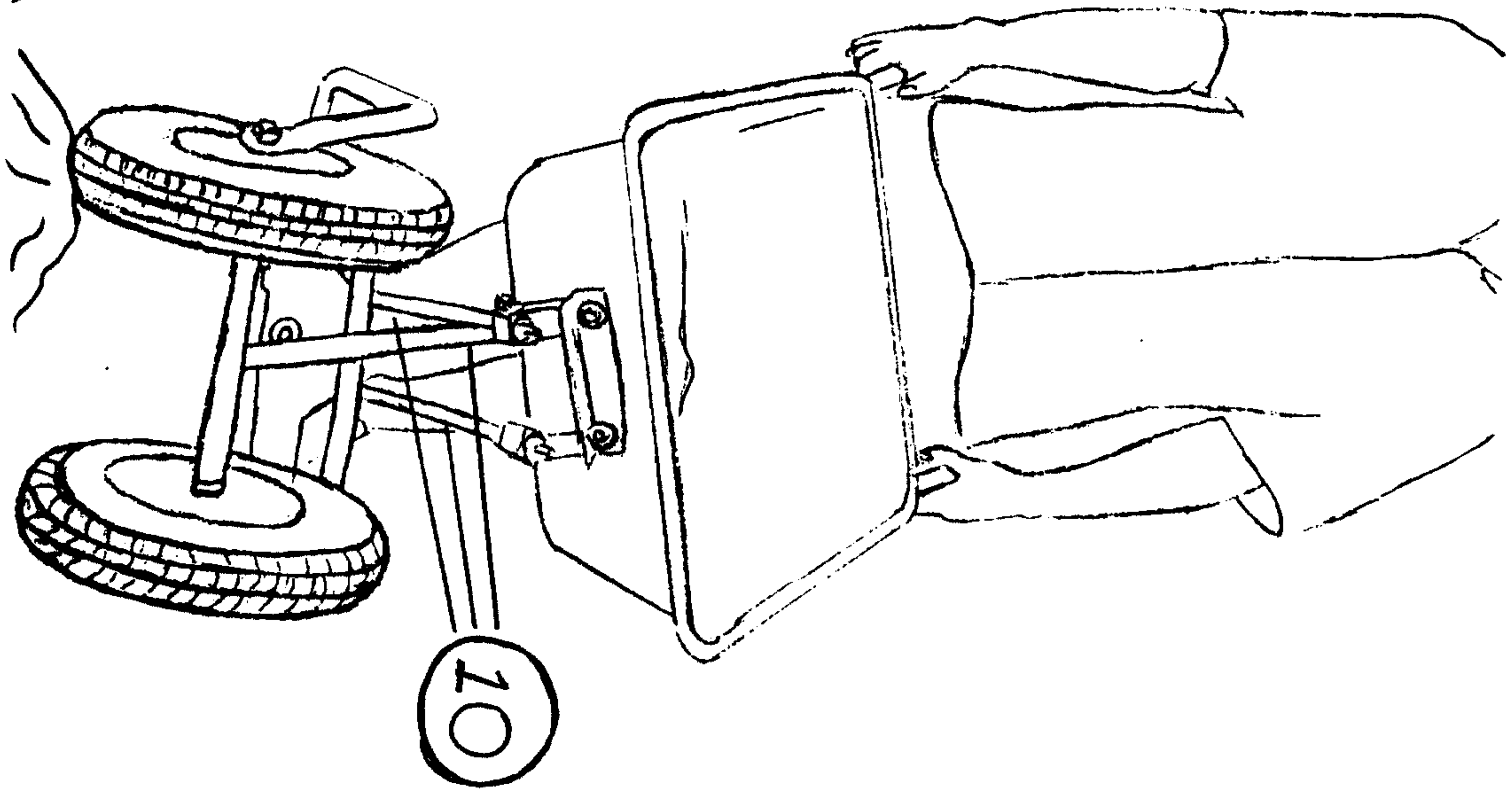
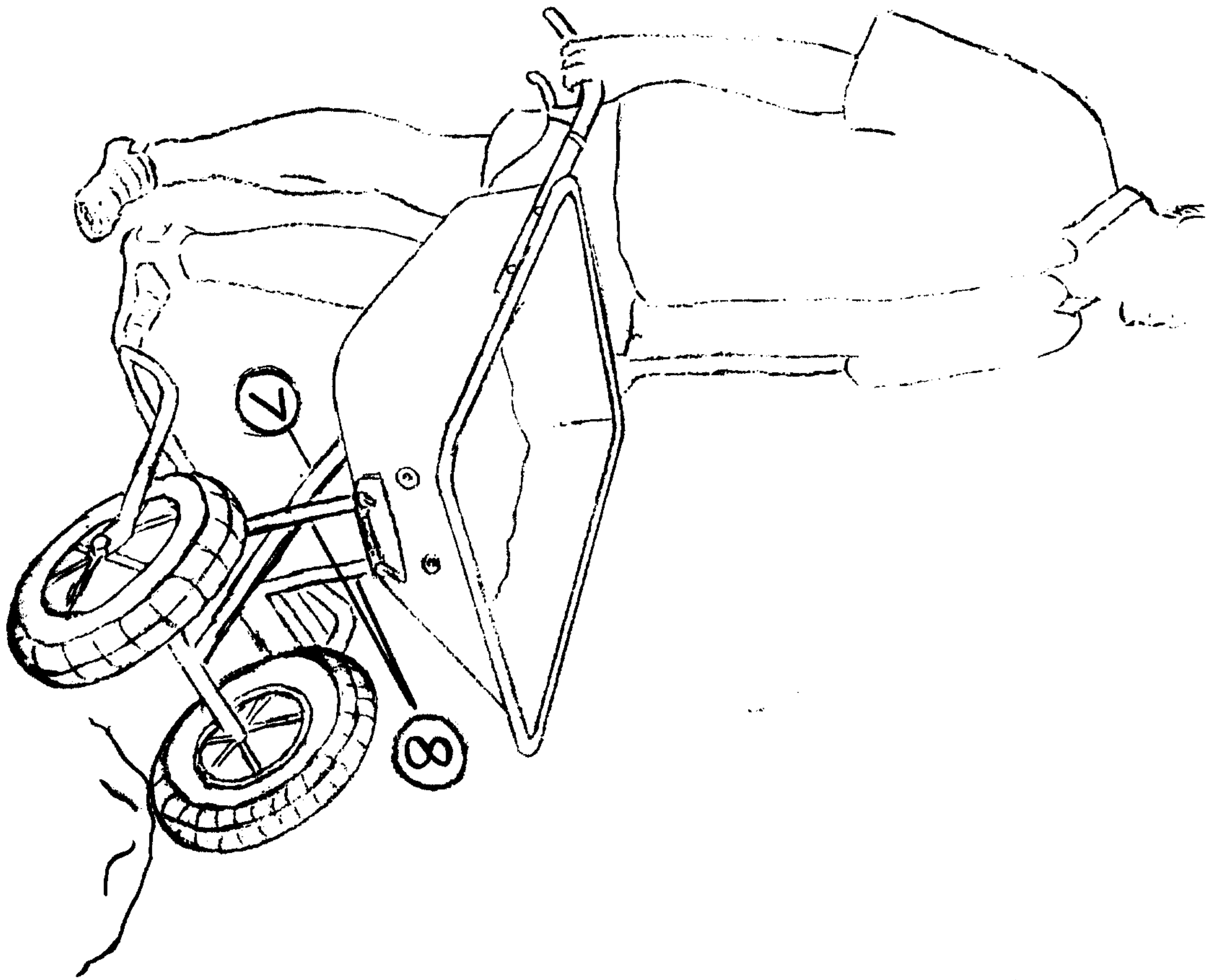

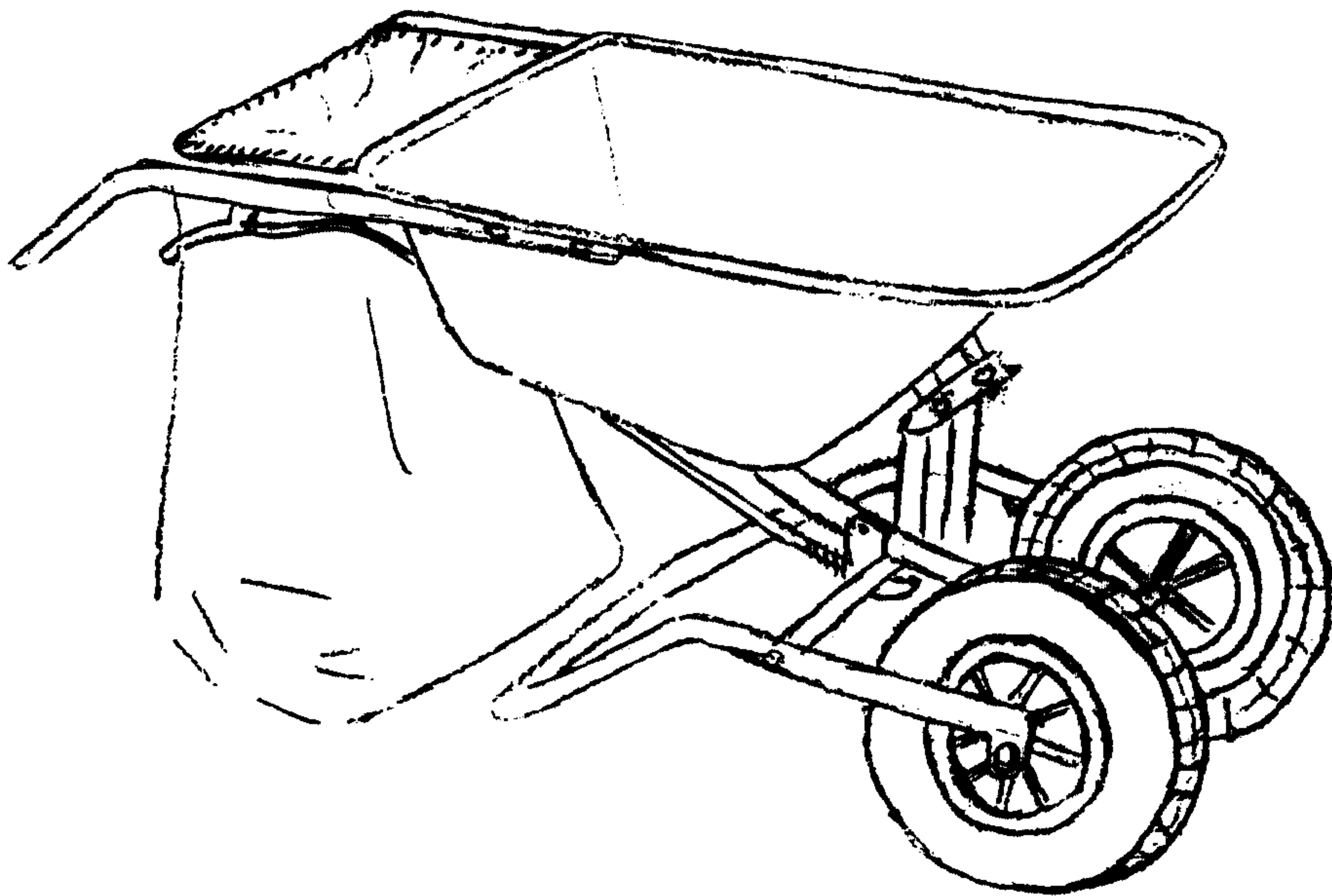
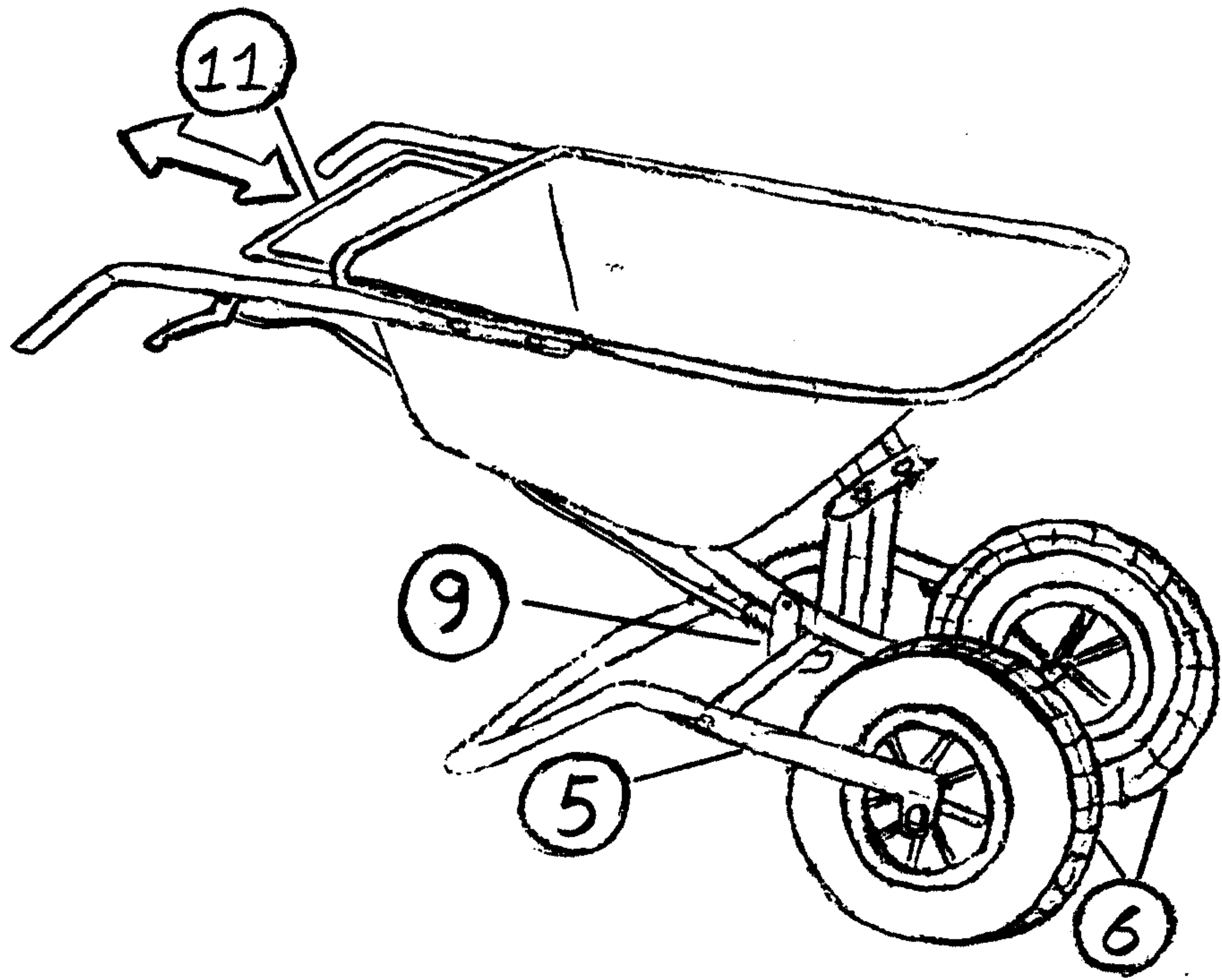

Application number / numéro de demande: 2404372

Figures: _____

Pages: 6 + 7

Unscannable items
received with this application
(Request original documents in File Prep. Section on the 10th floor)

Documents reçu avec cette demande ne pouvant être balayés
(Commander les documents originaux dans la section de préparation des dossiers au
10^{ème} étage)