

(19) World Intellectual Property Organization
International Bureau



(43) International Publication Date
17 May 2001 (17.05.2001)

PCT

(10) International Publication Number
WO 01/35266 A2

- (51) International Patent Classification⁷: **G06F 17/10**
- (21) International Application Number: PCT/CA00/01300
- (22) International Filing Date:
1 November 2000 (01.11.2000)
- (25) Filing Language: English
- (26) Publication Language: English
- (30) Priority Data:
09/435,816 8 November 1999 (08.11.1999) US
- (71) Applicant (for all designated States except US): **UNIVERSITÉ DE MONTRÉAL [CA/CA]**; 2900 Édouard-Montpetit, Montréal, Québec H3T 1J4 (CA).
- (72) Inventors; and
- (75) Inventors/Applicants (for US only): **BERTRAND, Michel, J. [CA/CA]**; 985 Beatty, Verdun, Québec H4H 1Y2 (CA). **ZIDAROV, Dimo [BG/CA]**; 7265 Malo Street, Brossard, Québec J4Y 1B8 (CA).
- (74) Agents: **ANGLEHART, James et al.**; Swabey Ogilvy Renault, Suite 1600, 1981 McGill College Avenue, Montréal, Québec H3A 2Y3 (CA).
- (81) Designated States (national): AE, AG, AL, AM, AT, AU, AZ, BA, BB, BG, BR, BY, BZ, CA, CH, CN, CR, CU, CZ, DE, DK, DM, DZ, EE, ES, FI, GB, GD, GE, GH, GM, HR, HU, ID, IL, IN, IS, JP, KE, KG, KP, KR, KZ, LC, LK, LR, LS, LT, LU, LV, MA, MD, MG, MK, MN, MW, MX, MZ, NO, NZ, PL, PT, RO, RU, SD, SE, SG, SI, SK, SL, TJ, TM, TR, TT, TZ, UA, UG, US, UZ, VN, YU, ZA, ZW.
- (84) Designated States (regional): ARIPO patent (GH, GM, KE, LS, MW, MZ, SD, SL, SZ, TZ, UG, ZW), Eurasian patent (AM, AZ, BY, KG, KZ, MD, RU, TJ, TM), European patent (AT, BE, CH, CY, DE, DK, ES, FI, FR, GB, GR, IE, IT, LU, MC, NL, PT, SE, TR), OAPI patent (BF, BJ, CF, CG, CI, CM, GA, GN, GW, ML, MR, NE, SN, TD, TG).
- Published:**
— Without international search report and to be republished upon receipt of that report.
- For two-letter codes and other abbreviations, refer to the "Guidance Notes on Codes and Abbreviations" appearing at the beginning of each regular issue of the PCT Gazette.

(54) Title: MEASUREMENT SIGNAL PROCESSING METHOD

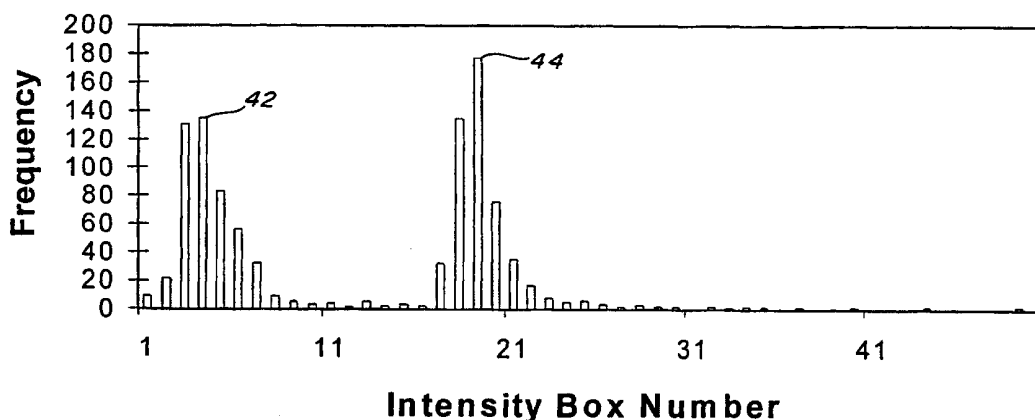

WO 01/35266 A2

(57) Abstract: A method of processing data representing intensity values of a measurement signal as a function of a discrete variable such as time, which signal being characterized by series of peaks mixed with a substantially regular background noise, provides efficient noise attenuation and peak detection capabilities. When applied to a two-dimensional system, the method comprises an initial step of forming an intensity histogram vector representing a frequency distribution from the intensity values, which intensity histogram vector having N frequency vector components associated with corresponding N intensity sub-ranges within a maximum range extending from a minimum intensity value to a maximum intensity value. This initial step is followed by a step of zeroing a portion of the data corresponding to the intensity values which are below an intensity threshold value derived from shape characteristics of the distribution. Then, the intensity threshold value is subtracted from each remaining portion of the data to obtain processed data representing the measurement signal in which each peak exhibits an enhanced signal-to-noise ratio. The method is also applicable to multi-dimensional measurement systems involving more than one variable, such as chromatography / mass spectrometry measurement techniques.

MEASUREMENT SIGNAL PROCESSING METHOD

Field of the invention

The present invention relates to the field of signal processing, and more particularly to methods of processing measurement signals
5 characterized by peaks mixed with background noise.

In recent decades, techniques for chemical analysis have substantially improved because of developments in electronics and computer sciences. Several techniques can nowadays detect and quantify extremely small amounts of materials with surprising selectivity and
10 specificity. For example, mass spectrometry is capable of detecting a single ion (atom or molecule). Thus, the analytical instrument is no longer the limiting factor in chemical analysis. The limiting factor has become the ability to extract the signal of interest from the interfering signal that can be due to the presence of other substances, electrical noise, spikes or other
15 sources of noise involved in the analytical procedure. Although primary analytical techniques usually provide a two dimensional graph of signal intensity as a function of some variable (wavelength, mass, distance, time etc.) , many hyphenated techniques have been introduced in recent years that can provide multidimensional data matrix. This is the case for
20 techniques such as gas chromatography-mass spectrometry (GC/MS), liquid chromatography-mass spectrometry (LC/MS), pyrolysis-mass spectrometry (Py-MS) and other techniques where a separation technique or other is coupled to a spectroscopic technique. When using these instruments, a multidimensional data matrix (intensity-variable₁-variable₂) is
25 obtained from which the signal of interest must be extracted.

Background signal has become an important factor in the interpretation of analytical data as instrument sensitivity is constantly increased, as discussed by Cairns et al. in *Mass. Spectrom. Rev.*, 8, (1989), p. 93., by Tomer et al. in *J. Chromatogr.*, 492, (1989), p.189., and
30 by Niessen et al. in "*Liquid Chromatography-Mass Spectrometry*", ed. by J. Cazes, Marcel Dekker Inc., New York, (1992), p.399. In hyphenated

techniques such as LC/MS, GC/MS and Py-MS, background signal can mask the signals of interest. In GC/MS, the phenomenon is mainly due to the ionization of the chromatographic stationary phase. In LC/MS, since the mobile phase is overwhelmingly more concentrated than the analytes, it can create a background signal that will mask the elution peaks of interest and contaminate the mass spectra which makes interpretation very difficult. In Py-MS, a significant background signal is generated during pyrolysis that dilutes the information content of the mass spectra obtained during analysis.

Fig. 1A shows a typical LC/MS chromatogram obtained for a pharmaceutical mixture using a prior art method, in the form of the total ion current (TIC) intensity in percentage as a function of time as a first variable. Fig. 1B shows the single ion current (SIC) chromatogram obtained with the same mixture at a specific value for the mass as a second variable (mass=101). The TIC chromatogram is obtained by compressing the mass axis, intensities of all the mass peaks being added and projected on the intensity axis, as well known in the art. Each of the elution peaks present in the chromatogram of Fig. 1A has a third dimension which is the mass spectrum. It can be seen from Fig. 1A that it is clearly difficult to determine the position of the elution peaks from the raw TIC chromatogram data, because of the variation and intensity of the background noise signal, a portion of which being generally designated at 22. Because the background signal is high, it is difficult to determine the true elution peaks corresponding to the compounds present in the mixture. In a similar way, it can be seen from Fig. 1B that the raw mass spectrum peak data are so contaminated by background noise such as the spike appearing at time 179 and designated at 26, that it becomes very difficult to attempt identification of the compounds being present.

The need for algorithms that can remove background signal from analytical data in these techniques has been recognized for several years and many approaches have been suggested for GC/MS, ICP/MS AND

LC/MS , by Lee et al. in *Anal. Chem.*, 63, (1991), p.357., by Burton et al. in *Spectrochimica Acta*, Vol. 47B, 14, (1992), p. E1621 and by Hau et al. in *Spectrochimica Acta*, Vol. 48B, 8, (1993), p. E1047. Although some of these approaches have merit under given experimental conditions, they are generally not satisfactory for a broad scope of applications involving various experimental conditions. One of the simplest prior art approach that has been suggested and used over the years consists in subtracting the spectrum or an average of the spectra that come just before or after the elution peak from that contained under the elution peak. This approach can be efficient if the spectrum before the elution peak is representative of the background and if it is of substantially lower intensity. The elution peak has to be more intense than the background for this technique to be used. In many cases, this is not the case and erroneous results can be obtained because of over or under estimation of the background signal to be subtracted. Other approaches relying on smoothing techniques have been suggested to detect elution peaks , such by Geladi et al. in *Analytica Chimica Acta*, 185, (1986), p.1., by Laeven et al. in *Analytica Chimica Acta*, 176, (1985), p.77., by Doursma et al. in *Analytica Chimica Acta*, 133, (1981), p.67., by Malinowski et al. in *Anal. Chem.*, 49, (1977), p.606., by Enke et al. in *Anal. Chem.*, 48, (1976), p.705A., and by Lam et al in *Anal. Chem.*, 54, (1982), p.1927. However, even if these approaches allow the determination of the elution peak, they do not remove interfering signal in the mass spectra which can lead to problems. Smoothing techniques treat the signal in the intensity-time plane but not in the mass-intensity plane. An other example of smoothing approach is disclosed in US Patent No. 4,837,726 issued on June 6, 1989 to Hunkapiller. Another approach as suggested by Biller et al. in *Analytical Letters*, 7, (1974), p.515., is based on the optimization of ion signals with time. However, this approach is only useful when the background signal is small relative to the analyte signal and it fails to recognize instrumental spikes from real elution peaks because spikes also create signal optimization with time. Lately, the

technique of maximum entropy has been described in "*Modern Spectrum Analysis*", Childers, D. G. Editor, New York, IEEE Press, 1978, and by Kay et al in *Proceedings of the IEEE*, Vol. 69, pp 1380-1419, 1981, by Ferrige et al. in *Rapid Commun. in Mass Spectrom.*, 5 (1991) 370, by Ferrige et al.
5 *in Rapid Commun. in Mass Spectrom.*, 6 (1992) 707 and by Ferrige et al. in *Rapid Commun. in Mass Spectrom.*, 5 (1992) 765. However, this technique is lengthy and does not produce mass spectra that are stripped of the interfering ions. Even though many other prior art processing methods have been proposed, such as those described in the followings
10 US Patents: US 4,314,343, US 4,524,343, US 4,546,643, US 4,802,102, US 5,291,426, US 5,737,445 and US 5,592,402, there is still a need for simpler methods of processing measurement signals which are effective to attenuate background noise, allowing peak detection in a broad scope of applications involving various experimental conditions.

15 **Summary of the invention**

It is therefore a object of the present invention to provide methods of processing measurement signals characterized by at least one peak mixed with a substantially regular background noise, which facilitate peak detection and interpretation of data obtained with measurement techniques
20 such as those used in analytical experiments.

According to above object, from a broad aspect of the present invention, there is provided a method of processing data representing intensity values of a measurement signal as a function of a discrete variable, the signal being characterized by at least one peak mixed with a
25 substantially regular background noise, the intensity values being comprised within a main intensity range. The method comprises the steps of: i) forming an intensity histogram vector representing a frequency distribution from the intensity values, the intensity histogram vector having N frequency. vector components associated with corresponding N
30 intensity sub-ranges; ii) zeroing a portion of the data corresponding to the intensity values which are below an intensity threshold value I_t derived

from shape characteristics of the distribution; and iii) subtracting the determined intensity threshold value from each remaining portion of the data to obtain processed data representing the measurement signal with the peak exhibiting an enhanced signal-to-noise ratio.

5 From a further broad aspect of the present invention, there is provided a method of processing data representing intensity values of a measurement signal as a function of a first and a second discrete variable, the signal being characterized by at least one peak mixed with a substantially regular background noise, the intensity values as a function of
10 the first discrete variable and associated with each one of M successive values for the second discrete variable being comprised within a corresponding main intensity range. The method comprises the steps of: i) forming M intensity histogram vectors F_j representing frequency distributions from the intensity values associated with the M successive
15 values of the second discrete variable, each intensity histogram vector having N_j frequency vector components associated with corresponding N_j intensity sub-ranges, with $j = 1, \dots, M$; ii) zeroing portion of the data corresponding to the intensity values associated with each distribution which are below an intensity threshold value I_{cj} derived from shape
20 characteristics of each distribution; and iii) subtracting the intensity threshold value from each remaining portion of the data corresponding to the intensity values associated with each distribution, to obtain processed data representing the measurement signal with the peak exhibiting an enhanced signal-to-noise ratio.

25 It a further object of the invention to provide a software product data recording medium in which program code is stored, which program code will cause a computer to perform the method steps of processing data representing intensity values of a measurement signal according to the present invention.

It is yet a further object of the invention to provide a computer data signal embodied in a carrier wave, said data signal comprising processed data representing the measurement signal with the peak exhibiting an enhanced signal-to-noise ratio according to the present invention.

5

Brief description of the drawings

A preferred embodiment of the processing method according to the present invention will now be described in detail in view of the accompanying drawings in which:

10 Fig. 1A is a graph representing a typical LC/MS TIC chromatogram obtained for a pharmaceutical mixture using a prior art method.

Fig. 1B is a graph representing a SIC chromatogram as obtained with the same mixture referred to in Fig.1 for a specific mass value.

15 Fig. 2A is a graph representing the LC/MC TIC chromatogram of Fig. 1A after processing with the method according to the present invention.

Fig. 2B is a graph representing the SIC chromatogram of Fig. 1B after processing with the method according to the present invention.

20 Fig. 3A is a graph representing a TIC chromatogram as a bi-dimensional representation of the intensity data matrix where the mass axis has been contracted.

Fig 3B is a graph representing a tri-dimensional chromatogram from which the graph of Fig. 3A was derived.

25 Fig. 4 shows an array representing an intensity histogram vector associated with a frequency distribution of f_i from the intensity values of a processed measurement signal.

Fig. 5A and 5B show a TIC chromatogram and a SIC chromatogram of mass 50 respectively, which were obtained from another experimental analysis.

30 Fig. 6 is a graph representing a frequency distribution from the measured intensity values corresponding to the chromatogram of Fig. 5B.

Fig. 7 is a graph representing a typical narrow frequency distribution.

Fig. 8 is a graph representing a typical medium frequency distribution.

5 Fig. 9 is a graph representing a typical broad frequency distribution.

Fig. 10A and 10B are graphs representing another example of SIC chromatograms corresponding to a medium frequency distribution for a mass value of 58 before and after processing respectively.

10 Fig. 11A and 11B are graphs representing another example of SIC chromatograms corresponding to a broad frequency distribution for a mass value of 60 before and after processing respectively.

Figs. 12A and 12B are graphs representing another example of a SIC chromatogram at a mass value of 147 and a corresponding TIC, in which the gain was modified during the course of the experiment.

15 Fig. 13 represents the intensity frequency distribution obtained for the data from which Fig. 12A was derived.

Figs. 14A and 14B are graphs showing respectively a raw data chromatogram and a match chromatogram obtained from a commercial library of mass spectra.

20 Figs. 15A and 15B are graphs showing respectively a processed data chromatogram and a match chromatogram obtained from a commercial library of mass spectra.

Fig. 16 is a representation of a processed data matrix obtained as part of the spike elimination function of the method.

25 Fig. 17 shows an array representing a cumulative intensity histogram vector obtained from processed data such as represented at Fig. 16 as part of the peak detection function of the method.

Detailed description of the preferred embodiment

30 The approach used for the method according to the present invention allows determination and attenuation of a background signal present in a multi-dimensional data set representing a measurement

signal, and particularly in bi-dimensional and tri-dimensional intensity/variable systems. This approach also allows the determination of elution peaks, i.e. signal components of interest that appears with time. The resulting data has an increased information content in all reference
5 planes related to the intensity of the signal (intensity-mass, intensity-time). A first objective of the method described hereinafter is to process data in order to remove the useless background signal therefrom, a second objective being to detect substantially all peaks of interest, particularly those having small intensity value. In doing so, the information content is
10 significantly increased which facilitates data interpretation and lowers detection limits of the analytical technique used. The proposed method can be applied to many analytical techniques and can rapidly process analytical data. In these cases, it offers several advantages because it removes background signal, which is mainly due to the presence of
15 interfering substances and instrumental conditions, and spikes from the data, and allows the determination of elution peaks. In techniques such as GC/MS, LC/MS and Py-MS it strips the overall recording from useless signal and enhances the signals of interest which facilitates the detection of elution peaks and the interpretation of the data.

20 Although the following description refers to applications of the present invention for measurement signals obtained with mass spectrometry (GC/MS, LC/MS) techniques involving a tri-dimensional representation (intensity-time-mass), it is to be understood that methods according to the present invention are not limited to such techniques. It is
25 of general use and can be applied with many measurement techniques where the background signal has to be removed and a peak profile have to be detected.

The principle of the method will now be explained with reference to examples involving separation techniques (GC, LC) coupled to mass
30 spectrometry (GC/MS, LC/MS). In these techniques, a mixture is introduced into the instrument and compounds are separated in the

chromatographic section while as they elute into the mass spectrometer their mass spectra are recorded. The mass spectrometer is continuously scanned according to a repetitive scanning (REP) where it covers a range of mass values, or may alternate between selected mass values such as in
5 selected ion monitoring (SIM) and multiple reaction monitoring (MRM). Thus, mass spectra or specific ion signals are recorded with time. One obtains a tri-dimensional data matrix with intensity, time and mass axis. Generally, the chromatogram is reconstructed in the form of the total ion current (TIC) which is obtained by summing the total ion current in every
10 spectrum. The TIC chromatogram represents a bi-dimensional representation of the data matrix where the mass axis has been contracted as shown in Fig. 3A in view of Fig. 3B. Every peak 28, 28' appearing in the TIC chromatogram shown in Fig. 3A has a corresponding mass spectrum 30, 30' as shown in Fig. 3B, from which compounds can be identified
15 and/or quantified. However, in many cases, the spectrum is heavily contaminated by interfering signals and the elution peak profile of the TIC chromatogram is lost in the background. Hence, the elution profile can not be determined and it is difficult to interpret the spectrum corresponding to the compound because it contains ions signals that correspond to the
20 background rather to the substance of interest, as explained before with reference to Figs. 1A and 1B. Comparing Figs. 1A and 1B with Figs 2A and 2B respectively, it can be seen that most of the background signal has been removed, resulting in an enhanced signal-to-noise ratio for the elution peaks 20' and 24' shown in Figs. 2A and 2B respectively. Such useful
25 result can be particularly well appreciated with reference to peak eluted at time 186 and designated at 32 in Fig. 2A, which peak was practically undetectable in the TIC chromatogram raw data of Fig. 1A. It can further be seen that spike 26 shown in Fig. 1B was entirely eliminated by the processing method, allowing identification of main peaks 24'.

30 The method according to the present invention is based on two main hypotheses. First, the presence of a signal portion due to

background noise has a higher occurrence frequency than portions of interest which are due to isolated compounds. In other words, a signal portion due to background noise is observed more often than a portion signal due to a given component present in the sample. Second, during a measurement or analysis, the number of scans (discrete time-steps) in which a single component elutes is much smaller than the total number of scans performed during the measurement or analysis. In order to calculate the intensity distribution of the signal measured for each mass as for the example shown in Figs. 3A and 3B, or more generally for each data channel as a function of time, data representing intensity values of the measurement and being comprised within a main intensity range are separated in intensity sub-ranges using the following equation:

$$\Delta I = (I_{\max} - I_{\min}) / N$$

(1)

wherein ΔI represents the main intensity range, I_{\min} and I_{\max} representing a minimum and a maximum intensity value, respectively and N being a selected number of intensity sub-ranges. I_{\min} is the minimum intensity recorded for a given mass or data channel with time, while I_{\max} is the maximum intensity recorded for a given mass or data channel with time. For the example shown in Figs. 2A and 2B, N was given a value of 50, as will be explained later in more detail. Then, an intensity histogram vector as represented by the array 32 shown in Fig. 4 is formed, which vector representing a frequency distribution of f_i from the intensity values. This intensity histogram vector has N frequency vector components associated with corresponding N intensity sub-ranges extending from I_{\min} to I_{\max} , each sub-range having a width ΔI . Once a vector structure as represented by array 32 has been determined, the intensity of the signal for each mass or data channel is read as a function of time or scan number, i.e. the mass-time plane in Fig. 3B, and depending on the

intensity, "1" is added in the appropriate intensity sub-range box 34 of Fig. 4 associated with each vector component. For example, if a first scan has an intensity that falls in the $I_{\min} + \Delta I$, "1" will be added to the box corresponding to f_1 . If a following second scan has an intensity that falls in the range of $I_{\min} + 3\Delta I$ "1" will be added to that box and so on. At the end of the process, i.e. when the intensity of a given mass or data channel for every scan has been placed in the appropriate box for all of the scans, a frequency of occurrence f_i is obtained for each intensity range box. The procedure is repeated for each mass or data channel until all of the data have been processed. Hence, for a given mass or data channel a frequency f_i is obtained representing the frequency of occurrence of the signal in a given intensity range and this for each intensity range from I_{\min} to I_{\max} . Since the intensity frequency of a signal belonging to a true compound is of a random, low frequency intensity and that of the background signal is contained within a range of high frequency intensities, the intensity range with the maximum frequency is considered as noise and should be removed.

Referring now to Figs. 5A and 5B, there are shown a TIC chromatogram and a SIC chromatogram of mass 50 respectively, which chromatograms were obtained from another experimental analysis. It can be seen that in the TIC chromatogram of Fig. 5A, true peaks are difficult to observed while true peaks 36 are well defined in the SIC chromatogram of Fig. 5B. However, a residual signal can be seen in the SIC chromatogram, its intensity being contained within a narrow, high frequency intensity range. After assigning the intensity of mass 50 in each scan to one of the boxes 34 in the intensity range array of Fig. 4, an intensity histogram vector representing a frequency distribution from the measured intensity values can be obtained for that mass or data channel, as shown in Fig. 6. It can be seen from Fig. 6 that a maximum frequency of occurrence, having a value of 240, is observed for the 8th and 9th intensity ranges, as

designated at numerals 38 and 40, indicating that the background signal is within these intensity ranges. Thus, intensity values below or equal to the corresponding threshold intensity value for these ranges should be rejected because they are below the noise level, while this value should be subtracted of those values above to correct them from the background signal.

The actual threshold intensity I_c that should be considered as noise, and that must be subtracted accordingly, depends on the measurement technique used and on the distribution of intensities. The precise determination of this value is essential because if it is underestimated the background signal will remain after treatment, and if it is overestimated signals of interest may be removed from the data set which would lead to erroneous results. The method, in order to evaluate the background signal as precisely as possible, preferably uses the shape of the intensity frequency distribution. Intensity distributions will vary depending on the measurement technique used, on the amount of background signal, on experimental conditions etc. Because many factors can influence the shape of the intensity frequency distribution the method will determine the threshold signal to be subtracted as a function of the shape of the intensity frequency distribution. Depending on the analysis performed, it will preferably classify each intensity frequency distribution into one of two or three distinct categories, namely narrow, medium and broad category, and the background signal to be subtracted will depend on the type of distribution. Several criteria are used in order to determine in which category the intensity distribution is assigned. Prior to this assignment and to respect statistical requirements, the value chosen for N , the selected number of intensity sub-ranges found in equation (1) above, must be appropriate. An improper choice of value for N , and by way of consequence of the width ΔI of the intensity ranges, would skew the intensity distribution and render the statistics less reliable. Hence, the value of N will be preferably chosen according to the following rules:

N equals to about 50 if $I_{\max}/I_{\min} \leq 10,000$;

N equals to about 1,000 if $10,000 < I_{\max}/I_{\min} \leq 100,000$; and

(2)

N equals to about 10,000 if $100,000 < I_{\max}/I_{\min}$.

- 5 Once the value of N has been determined, it is possible to assign a frequency f_i to each of the N intensity boxes 34 ($i=1$ to N) and the intensity value I_i associated to each box can be determined using the following equation:

10
$$I_i = I_{\min} + \Delta I$$

(3)

- The intensity distributions obtained for each mass or data channel after the choice of the appropriate N are then analyzed for the determination of the type of distribution. However, before conducting this analysis, a test is preferably done to determine and attenuate rare mass or channel signals. In this test, the ratio of the sum of the frequencies at each mass or data channel j over the total number of scans or point recorded (TSN) is calculated, and the following test is applied:

20
$$\frac{\sum_{i=1,N} f_{ij}}{\sum_{\substack{i=1,N \\ J=1,K}} f_{ij}} \leq T_r$$

(4)

- wherein T_r is a rarity threshold value. For example, assuming a value $T_r = 0.1$, If equation (4) is satisfied, then an intensity value $I_r = 0.05I_{\max}$ is subtracted from the data channel. This ensures that statistics on a small number of sample does not bias the results.
- 25

The following steps regard the classification of intensity frequency distributions. For each distribution corresponding to a given mass of data channel j , a main intensity range extends from a minimum intensity value $I_{\min j}$ to a maximum intensity value $I_{\max j}$. Each distribution can be classified in one of at least a first and a second category of shape characteristics defined by:

$$T_s < \frac{f(I_{\max j})}{\sum_{i=1,N} f_{ij}} \text{ for the first category; and}$$

10 (5)

$$\frac{f(I_{\max j})}{\sum_{i=1,N} f_{ij}} \leq T_s \text{ for the second category;}$$

wherein T_s is a shape threshold value being selected to allow each distribution to be classified in the first category whenever it exhibits a substantially narrow shape, $f(I_{\max j})$ being a frequency value associated with the maximum intensity value $I_{\max j}$, while f_{ij} represents a value for each frequency vector component of index i associated with each vector F_j . Typically, a distribution is considered as being classified in the first, narrow category whenever the first condition above is met with $T_s = 90\%$. For example, if the maximum frequency in the intensity range of a given distribution has a value $I_{\max j} = 300$ and the sum of all frequencies in the distribution has a value $\sum_{i=1,N} f_{ij} = 325$, which represents 92.3%, the distribution will be considered as narrow. Figure 7 shows an example of such narrow distribution. In the case of a narrow distribution that is assumed to be normal (Gaussian), the value of the threshold intensity I_{cj} to be subtracted will be preferably determined from the value of the

15

20

25

standard deviation σ_j of the distribution j . The intensity threshold value I_{cj} for the first, narrow category is defined by :

$$I_{cj} = I_{\max j} + 1; \text{ whenever } \sigma_j < T_d; \text{ and}$$

5 (6)

$$I_{cj} = I(f_{\max j}); \text{ whenever } \sigma_j \geq T_d;$$

wherein $I(f_{\max j})$ is an intensity value associated with a maximum frequency value $f_{\max j}$ of each vector F_j , T_d being a threshold value associated with the standard deviation σ_j of the distribution. Typically, a threshold value T_d of about 0.9% is used. Alternatively, whenever a distribution satisfies the second condition set forth at (5) above, it can be considered as belonging to the second category representing medium and broad distributions. Conveniently, a second shape threshold value T'_s can be defined to segregate between medium and broad frequency distributions, in which case, we have:

$$T'_s \leq \frac{f(I_{\max j})}{\sum_{i=1, N} f_{ij}} \leq T_s \text{ for a medium frequency distribution,}$$

and

20 (7)

$$\frac{f(I_{\max j})}{\sum_{i=1, N} f_{ij}} \leq T'_s \text{ for a broad frequency distribution.}$$

Typically, a second shape threshold value T'_s of about 30% used. Example of medium and broad frequency distributions are depicted in Figs. 8 and 9 respectively. For medium and broad frequency distributions, the intensity threshold value I_{cj} to be subtracted is calculated in the following way:

$$I_{cj} = I_{centj} P$$

(8)

$$I_{centj} = \frac{\sum_{i=i_{maxj-w}}^{i_{maxj+w}} f_{ij} I_{ij}}{\sum_{i=i_{maxj-w}}^{i_{maxj+w}} f_{ij}}$$

(9)

5 wherein I_{centj} is a centroid intensity value for the distribution;

P is a weighing factor depending from the shape characteristics and the measurement signal, the latter depending from the specific measurement technique used;

i_{maxj} is an index value corresponding to the maximum frequency

10 value f_{maxj} ;

w is a discrete width parameter value, and

I_{ij} represents one of the intensity values corresponding to the frequency vector component of index i of each vector F_j . Typically, the width parameter is given a value of $w=3$, so that the seven highest

15 frequencies in the distribution are determined and the centroid intensity value is calculated using equation (9) which value is used to obtain the intensity threshold value I_{cj} from equation (8). The method includes a step of zeroing each portion of the data corresponding to the intensity values which are below the intensity threshold value I_{cj} . Then, the intensity

20 threshold value I_{cj} is subtracted from each remaining portion of the data corresponding to the remaining intensity values, to obtain processed data representing the measurement signal wherein each peak exhibits an enhanced signal-to-noise ratio. Examples of SIC chromatograms corresponding to medium and broad frequency distributions for mass

25 values of 58 and 60 respectively are shown in Figs. 10 and 11, before (Figs. 10A and 11A) and after (Figs. 10B and 11B) processing with the

method. It can be observed from Fig. 11 that there is a fluctuation in the background noise level that leads to a broad distribution.

Beside the above examples where the background noise is substantially regular, there are instances where the experimental conditions may vary during the course of an analysis, thus modifying the intensities measured. In such cases, an abrupt variation in background intensity (increase or decrease) can be observed which modifies the statistical parameters. An example of an analysis in which the gain was modified during the course of the experiment is shown in Figs. 12A and 12B respectively representing a SIC chromatogram at a mass value of 147 and a corresponding TIC. In such a case, the statistics are modified and the intensity frequency distribution can give a function with more than one maximum, as shown in Fig. 13, which represents the intensity frequency distribution obtained for the data from which Fig. 12A was derived. The distribution shows two maxima 42 and 44 which result from the change in experimental conditions during analysis. The data represented in Fig. 13 is typical of a distribution obtained in a set of statistically unrelated data. In such a case, the algorithm is made to process the two portions of the data set characterized by their respective substantially regular background noise in separate fashions. Thus, in the example above, the data set would be treated as described previously from time scans 1-525 and from time scans 526-1020. The same principles as described before apply.

Referring now to Figs. 14A and 14B, it is shown a match obtained when searching the raw data (Fig. 14A) against a commercial library of mass spectra. It is obvious that although a match is found (Fig. 14B) which corresponds to a 5-dodecinol, it is of poor reliability by comparison of the mass spectrum used with that provided by the library. However, as shown in Figs. 15A and 15B, when processed data (Fig. 15A) is matched against the library, a resulting match (Figure 15B) corresponding to L-(-)-menthol is obtained. It can readily be seen that there is a striking similarity between the spectrum from the library and that obtained by treatment of the data,

rendering the match highly reliable. Thus, the method described using adjustable parameters that depend on the measurement technique used, can practically eliminate the unwanted signal while preserving the essential information and increase the information content and detection limits of a given analytical method. It modifies the total ion current and the mass spectra enhancing the information content at each level (TIC and mass spectrum).

Another feature of the present invention resides in the capability of determining elution profile once the background signal has been removed. This feature allows eluting peaks to be detected and their "purified" mass spectrum to be obtained. The data matrix after it has been processed to attenuated unwanted background signal yields a new data matrix (intensity`-mass-time). This matrix resembles the initial one but the intensity axis has been modified. The purpose of the further processing to determine elution peaks in the TIC that may not have been distinguishable in the raw data. The initial step in the procedure is to eliminate spikes peaks that may be present in the treated data. A spike is a transient signal whose lifetime is much shorter than that of a genuine signal. Thus, the method further comprises the step of zeroing portion of the data which is associated with a spike in the measurement signal, the spike data being characterized by one or more substantially non-zero values separated by adjacent substantially zero values over a corresponding maximum length l_s of the discrete variable, to remove the spike from the measurement signal. For example, a spike may be present for one or two scans (time samples) whereas a genuine signal will be persistent for 3-5 scans. In order to identify and remove these spikes, the algorithm analyzes each mass or data channel looking for a "010" or "0110" pattern in the data. In the preceding pattern, "0" and "1" represent the absence and presence of a signal intensity in the mass-time plane. Whenever the pattern is found, the algorithm removes the spike and set the signal to zero. After this is done, a new spike free data matrix is generated in which only intensities have

been modified. This new matrix will then be used to determine elution peak profiles. Before determining the elution peaks, the data matrix is further processed by substituting a unitary value for each remaining substantially non-zero value of the intensity values to form with remaining zero values M binary intensity vectors B_j each having K vector components b_{jk} .

Thus, the resulting data set as shown in Fig.16 has the form of a plane (mass-time) in which the values are either "0" or "1". The data set indicates whether a mass is present or absent (signal or no signal) in each of the scans. After having obtained the latter matrix, a cumulative vector is formed which has K vector components c_k associated with corresponding K values for the first discrete variable (time) from the binary intensity vectors B_j , the value for each cumulative vector component being defined by:

$$c_k = \sum_{j=1}^M b_{jk}, \text{ with } k = 1, \dots, K \quad (10)$$

The cumulative vector obtained is represented by the array 46 shown in Fig. 17. For each scan or sample, a sum of the occurrences is calculated for every mass in the mass range. For example, for scan no. 1 the algorithm will sum all the "1" present from the initial mass (m_1) to the final mass (m_M) and will place the value obtained c_1 in the first box 48 of the array 46. The same process is done for scan no. 2 leading to the value c_2 and so on up to c_K . Because the actual intensities have been replaced by "1", c_1 represents the number of masses present in scan 1, c_2 the number of masses present in scan 2 and so on. Thus, the array represents the frequency of the number of masses present as a function of scan number or time. If a component elutes from the chromatographic system during a given period of time, the number of masses present in a the corresponding

scan range will increase. Hence, the persistence of a high number of masses can be taken as an indication of an elution peak and the array 46 can be used to detect that elution peak (true signal).

Σm_{i_1}	Σm_{i_2}	Σm_{i_3}	Σm_{i_4}	Σm_{i_5}	Σm_{i_6}	Σm_{i_n}
scan 1	scan 2	scan 3	scan 4	scan n

Several instrumental factors can cause transient signals to be present in one or two scans. For example, a pressure variation during an LC/MS analysis can cause the background signal to rise temporarily causing an increase in the number of peaks recorded in one or two scans. In order to eliminate such transient signals, the algorithm conducts a second spike eliminating procedure. In a way similar to the one described previously for the data matrix, the cumulative vector represented by array 46 of Fig. 17 is transformed in the following way. Each vector component value c_k which is associated with a cumulative spike are given a zero value, cumulative spike data being characterized by one or more substantially non-zero values for the cumulative vector components separated by adjacent substantially zero values over a corresponding maximum length l_{cs} of the first discrete variable (time). Hence, a filtered cumulative vector having K vector components c'_k is generated from remaining substantially non-zero values for the cumulative vector components c_k . Referring to Fig. 17 as an example, for each scan box 48, the value of $\sum b_{jk}$ is read and it is replaced by 1 if it is a non-zero value, thus, yielding an array containing only a plurality of "0" and "1". After the conversion, a search for a "010" or "0110" pattern is conducted. When either pattern is found, they are replaced by "0" to eliminate spikes. This procedure does not affect the signals due to eluting components because their signal, in most cases, will be persistent for about 5 to about 10 scans.

Obviously, this condition varies depending on the measurement technique used. Conveniently, an input parameter W_s is used to calibrate the procedure. W_s represents the minimum number of scans during which the signal is expected to persist in a given technique. For example, in gas chromatography the value of W_s would be about 4 to 5. Hence, a spike pattern is generally considered to have a value lower than $W_s/2$. Once the spikes have been removed, the array is reconstructed with the real values of the intensities. More specifically, the method comprises a step of comparing successive vector components of the filtered vector components c_k for $k=1, \dots, K$ to detect a value increase from one of the vector component to a group of P_w vector components corresponding to the peak whenever:

$$W_s < P_w < W_m ;$$

(11)

wherein W_s and W_m are minimum and maximum peak width values respectively. Referring again to Fig. 17, the array 46 is then used to detect the elution peaks present the TIC. This is done by examining the intensity value in each of the boxes 48 of the array 16 and by looking at an increase of the signal from one box to the other. Since the spikes ("0x0" or "0xy0" patterns, where x and y represent non-zero values) have already been removed by the preceding operation, any increase in the intensity from one box to the other (slope increase) is indicative of an elution peak. When a peak is detected, the algorithm sets a start scan and defines the end scan when it finds a box with zero intensity. The maximum peak width W_m is defined as an input in order to set this parameter appropriately because it depends on the analytical technique used. Thus, the peak has to respect the slope condition and its width will be given by equation (11). The process is conducted for all the boxes 48 and at the end the position of the elution peaks have been detected. Then, the algorithm proceeds to

the determination of the peak profiles. For every peak contained in the interval of equation (11), the corresponding portion of the array is copied. For each scan within the elution profile, the number of masses present is calculated and the values obtained are ranked in increasing order. The
5 median (M) is calculated for all the values in the portion of the array and the intensity of ions in scans having a number of ions being lower than $M/2$ is set to zero. For mass spectrometric data obtained in the scanning mode the latter procedure is used. However, when the data have been obtained in selected ion/reaction monitoring (SIM, SIR, MRM), the final
10 procedure is skipped because of the reduced number of masses involved.

At the end of the procedure, a data matrix is obtained (intensity-mass-time) in which the intensity values have been processed but the mass and time axes are the same as in the raw data. The corresponding TIC can be used to reconstruct the chromatogram which yields scan
15 regions containing peak intensities (signal of interest) as those shown in Fig. 2A and 2B, while the regions between peaks of the TIC are given a zero value. This facilitates peak detection and integration in the TIC but also data interpretation. Actually, the mass spectra corresponding to each elution peak only include the masses with non-zero intensity that remain
20 after the background signal has been stripped. Thus, these spectra have an increased information content. It can be seen from Figs. 1A and 2A that the processed spectrum (Fig. 2A) and the raw spectrum (Fig. 1A) are quite different. Similarly, it can be seen from Figs. 14 and 15 that the processed spectrum (Fig. 15B) can easily be compared to that of a reference
25 spectrum (Fig. 15A), while the raw spectrum (Fig. 14B), contaminated by background signal, does not correspond to that of the reference spectrum (Fig. 14A) and easily leads to misinterpretation.

What is claimed is:

1. A method of processing data representing intensity values of a measurement signal as a function of a discrete variable, said signal being characterized by at least one peak mixed with a substantially regular background noise, said intensity values being comprised within a main intensity range, the method comprising the steps of:

i) forming an intensity histogram vector representing a frequency distribution from said intensity values, said intensity histogram vector having N frequency vector components associated with corresponding N intensity sub-ranges;

ii) zeroing a portion of said data corresponding to the intensity values which are below an intensity threshold value I_c derived from shape characteristics of said distribution; and

iii) subtracting said intensity threshold value from each remaining portion of said data to obtain processed data representing the measurement signal with said peak exhibiting an enhanced signal-to-noise ratio.

2. The method according to claim 1, wherein said main intensity range extends from a minimum intensity value I_{\min} to a maximum intensity value I_{\max} , said distribution being classified in one of at least a first and a second category of shape characteristics defined by:

$$T_s < \frac{f(I_{\max})}{\sum_{i=1,N} f_i} \text{ for the first category; and}$$

$$\frac{f(I_{\max})}{\sum_{i=1,N} f_i} \leq T_s \text{ for the second category;}$$

wherein T_s is a first shape threshold value being selected to allow said distribution to be classified in the first category whenever it exhibits a

substantially narrow shape, $f(I_{\max})$ being a frequency value associated with the maximum intensity value I_{\max} , f_i representing a value for each said frequency vector component of index i .

3. The method according to claim 2, wherein said intensity threshold value for said first category is defined by:

$$I_c = I(f_{\max});$$

wherein $I(f_{\max})$ is an intensity value associated with a maximum frequency value f_{\max} .

4. The method according to claim 2 or 3, wherein said intensity value for said second category is defined by:

$$I_c = I_{cent}P$$

wherein I_{cent} is a centroid intensity value for said distribution, P being a weighing factor depending from said shape characteristics and said measurement signal.

5. The method according to claim 4, wherein said centroid intensity value is defined by:

$$I_{cent} = \frac{\sum_{i=i_{\max-w}}^{i_{\max+w}} f_i I_i}{\sum_{i=i_{\max-w}}^{i_{\max+w}} f_i}$$

wherein i_{\max} is an index value corresponding to said maximum frequency value f_{\max} , w is a discrete width parameter value, I_i representing one of said intensity values corresponding to the frequency vector component of index i .

6. The method according to claim 1, further comprising after said step iii) the step of:

iv) further processing said processed data to detect said peak.

7. The method according to claim 6, wherein said step iv) comprises the steps of:

a) zeroing portion of said data which is associated with a spike in said measurement signal, said spike data being characterized by one or more substantially non-zero values separated by adjacent substantially zero values over a corresponding maximum length I_s of said discrete variable, to remove said spike from the measurement signal.

8. A method of processing data representing intensity values of a measurement signal as a function of a first and a second discrete variable, said signal being characterized by at least one peak mixed with a substantially regular background noise, the intensity values as a function of said first discrete variable and associated with each one of M successive values for said second discrete variable being comprised within a corresponding main intensity range, the method comprising the steps of:

i) forming M intensity histogram vectors F_j representing frequency distributions from the intensity values associated with the M successive values of said second discrete variable, each said intensity histogram vector having N_j frequency vector components associated with corresponding N_j intensity sub-ranges, with $j = 1, \dots, M$;

ii) zeroing portion of said data corresponding to the intensity values associated with each said distribution which are below an intensity threshold value I_{cj} derived from shape characteristics of each said distribution; and

iii) subtracting said intensity threshold value from each remaining portion of said data corresponding to said intensity values associated with each said distribution, to obtain processed data

representing the measurement signal with said peak exhibiting an enhanced signal-to-noise ratio.

9. The method according to claim 8, wherein said measurement signal is obtained from a separation technique-mass spectrometry measurement method, said first discrete variable is a discrete time variable, said second discrete variable is a discrete mass-related variable.

10. The method according to claim 9, wherein said separation technique is selected from the group consisting of gas chromatography, liquid chromatography and pyrolysis.

11. The method according to claim 8, wherein each said main intensity range extends from a minimum intensity value $I_{\min j}$ to a maximum intensity value $I_{\max j}$, each said distribution being classified in one of at least a first and a second category of shape characteristics defined by:

$$T_s < \frac{f(I_{\max j})}{\sum_{i=1, N} f_{ij}} \text{ for the first category; and}$$

$$\frac{f(I_{\max j})}{\sum_{i=1, N} f_{ij}} \leq T_s \text{ for the second category;}$$

wherein T_s is a shape threshold value being selected to allow each said distribution to be classified in the first category whenever it exhibits a substantially narrow shape, $f(I_{\max j})$ being a frequency value associated with the maximum intensity value $I_{\max j}$, f_{ij} representing a value for each said frequency vector component of index i associated with each said vector F_j .

12. The method according to claim 11, wherein said intensity threshold value for said first category is defined by:

$$I_{cj} = I_{\max j} + 1; \text{ whenever } \sigma_j < T_d; \text{ and}$$

$$I_{cj} = I(f_{\max j}); \text{ whenever } \sigma_j \geq T_d;$$

wherein $I(f_{\max j})$ is an intensity value associated with a maximum frequency value $f_{\max j}$ of each said vector F_j , T_d being a threshold value associated with a standard deviation σ_j for each said distribution.

13. The method according to claim 11 or 12, wherein said intensity threshold value for said second category is defined by:

$$I_{cj} = I_{centj} P$$

wherein I_{centj} is a centroid intensity value for each said distribution, P being a weighing factor depending from said shape characteristics and said measurement signal.

14. The method according to claim 13, wherein said centroid intensity value is defined by:

$$I_{centj} = \frac{\sum_{i=i_{\max j-w}}^{i_{\max j+w}} f_{ij} I_{ij}}{\sum_{i=i_{\max j-w}}^{i_{\max j+w}} f_{ij}}$$

wherein $i_{\max j}$ is an index value corresponding to said maximum frequency value $f_{\max j}$, w is a discrete width parameter value, I_{ij} representing one of said intensity values corresponding to the frequency vector component of index i of each said vector F_j .

15. The method according to claim 11, wherein the intensity values associated with said histogram vector F_j are attenuated prior to classifying the corresponding distribution, whenever:

$$\frac{\sum_{i=1,N} f_{ij}}{\sum_{\substack{i=1,N \\ J=1,K}} f_{ij}} \leq T_r$$

wherein T_r is a rarity threshold value.

16. The method according to claim 8, further comprising after said step iii) the step of:

iv) further processing said processed data to detect said peak.

17. The method according to claim 16, wherein said step iv) comprises the step of:

a) zeroing a portion of said data which is associated with a spike in said measurement signal, said spike data being characterized by one or more substantially non-zero values separated by adjacent substantially zero values over a corresponding maximum length l_s of said first discrete variable, to remove said spike from the measurement signal.

18. The method according to claim 17, wherein said step iv) further comprises the steps of:

b) substituting a unitary value for each remaining substantially non-zero values of said intensity values to form with remaining zero values of said intensity values M binary intensity vectors B_j , each having K vector components b_{jk} ;

c) forming a cumulative vector having K vector components c_k associated with corresponding K values for said first discrete variable from said binary intensity vectors B_j , a value for each said cumulative vector component being defined by:

$$c_k = \sum_{j=1}^M b_{jk}, \text{ with } k = 1, \dots, K ;$$

d) zeroing said vector component value c_k which is associated with a cumulative spike, said cumulative spike data being characterized by one or more substantially non-zero values for said cumulative vector components separated by adjacent substantially zero values over a corresponding maximum length l_{cs} of said first discrete variable, to generate a filtered cumulative vector having K vector components c'_k from remaining substantially non-zero values for said cumulative vector components c_k ;

e) comparing successive vector components of said filtered vector components c'_k for $k=1, \dots, K$ to detect a value increase from one of said vector component to a group of P_w said vector components corresponding to said peak whenever:

$$W_s < P_w < W_m;$$

wherein W_s and W_m are minimum and maximum peak width values respectively.

19. The method according to claim 18, wherein said measurement signal is characterized by a plurality of said peaks to which corresponds a plurality of said groups of P_w vector components, said P_w vector components of each said group are added to generate a ranking index associated to each said peak.

1/12

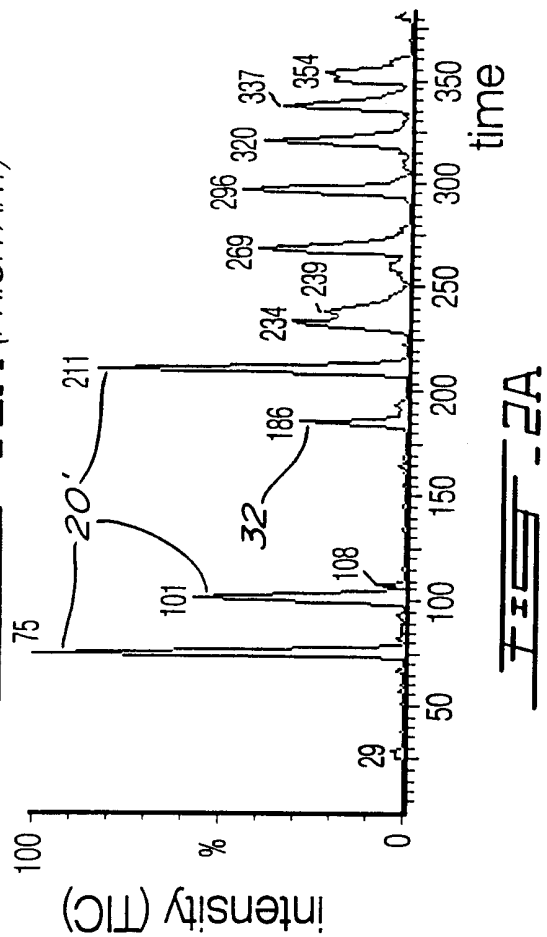
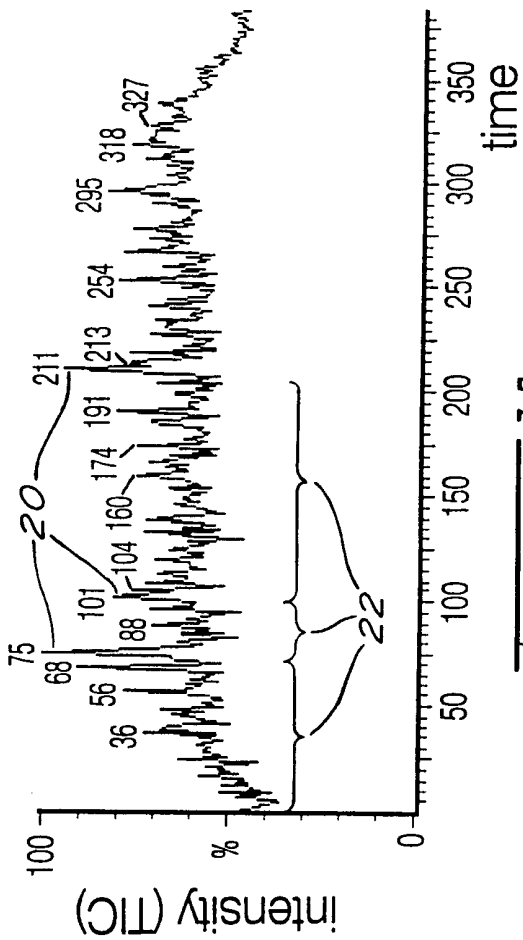
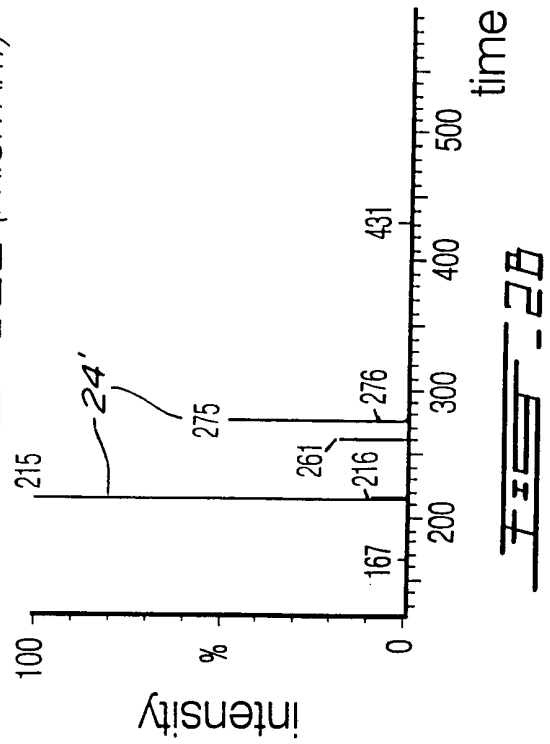
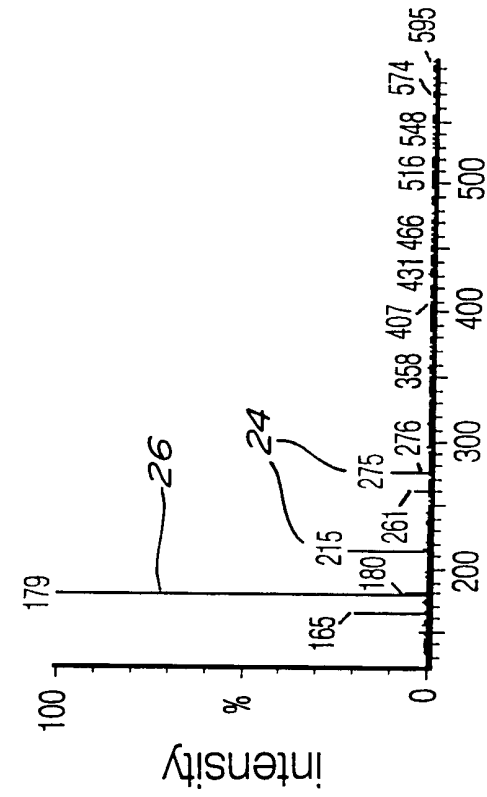

2/12

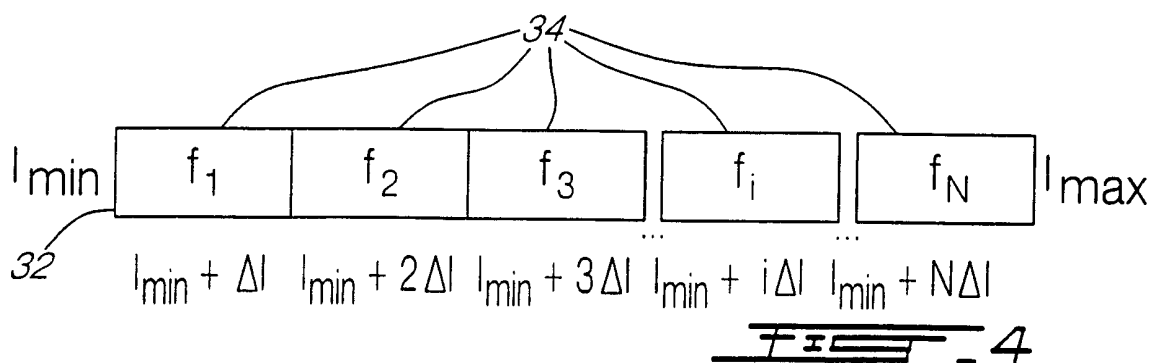
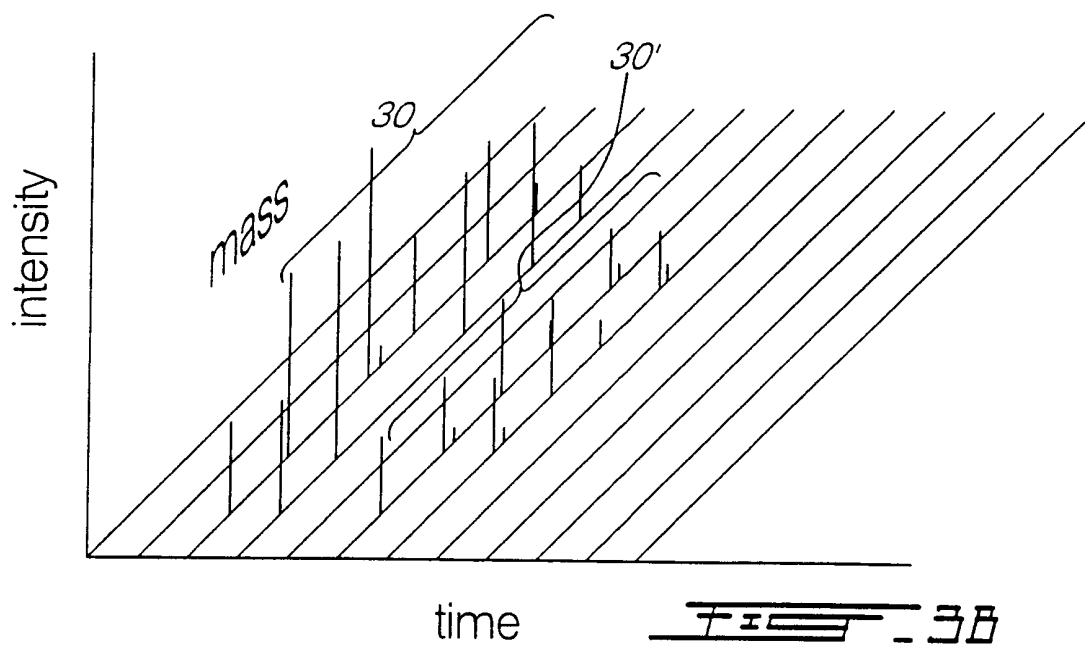
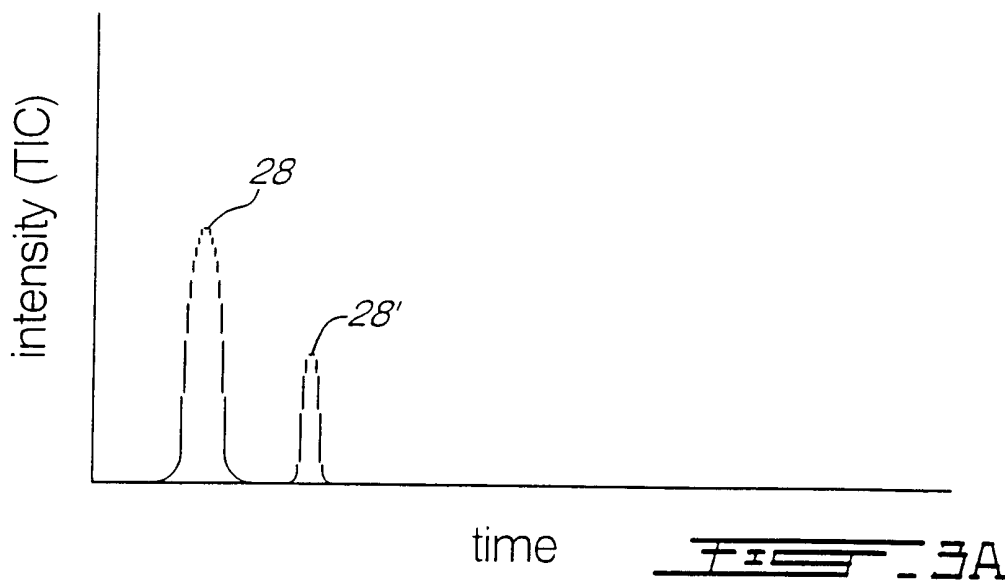

3/12

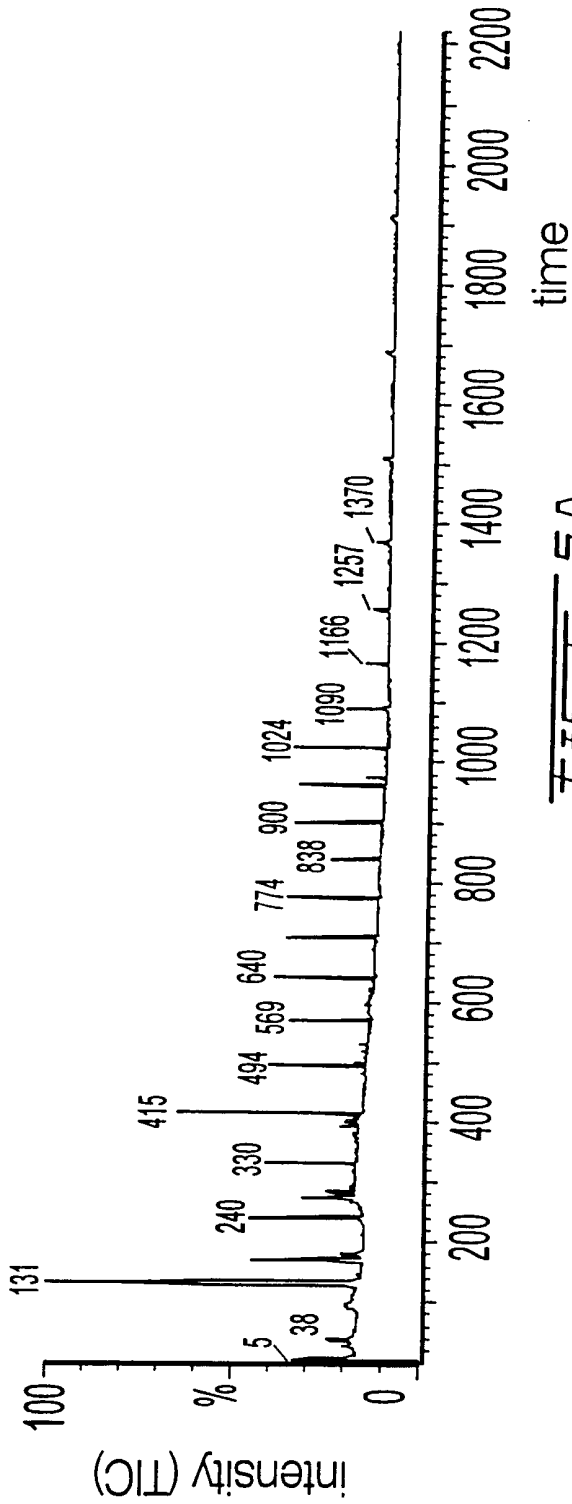

FIG. 5A

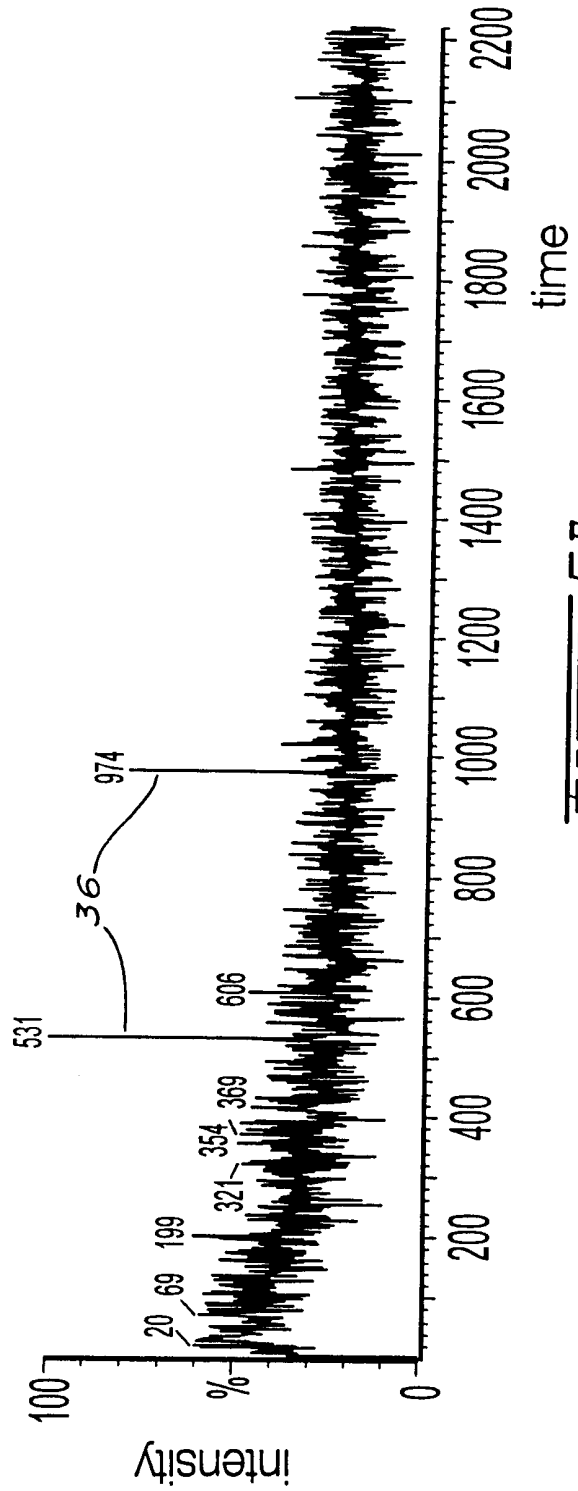

FIG. 5B

4/12

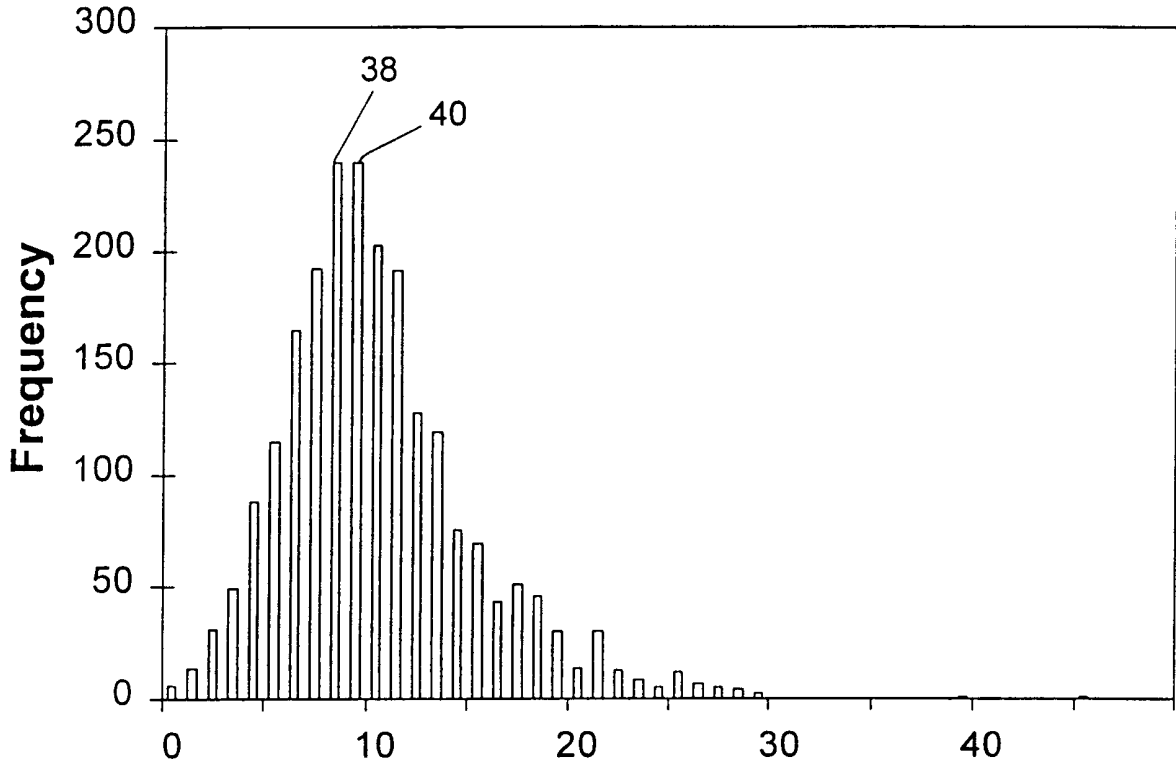

FIG. 6

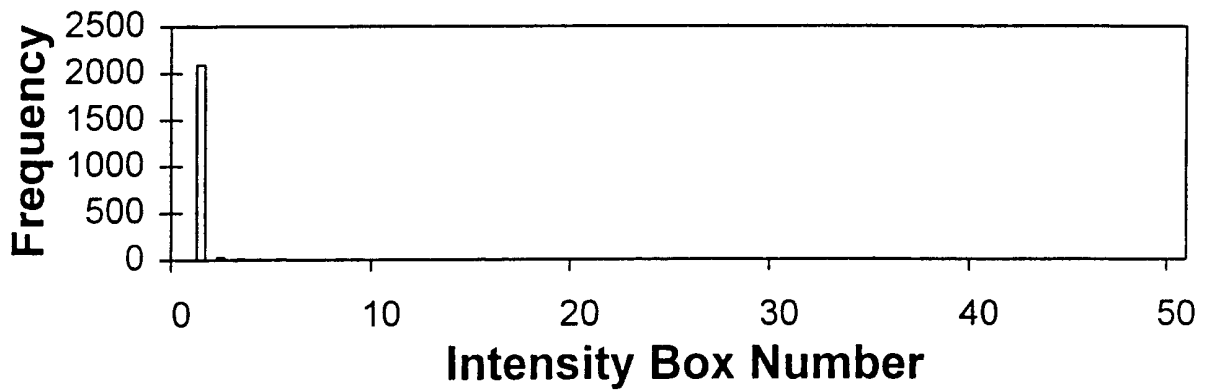
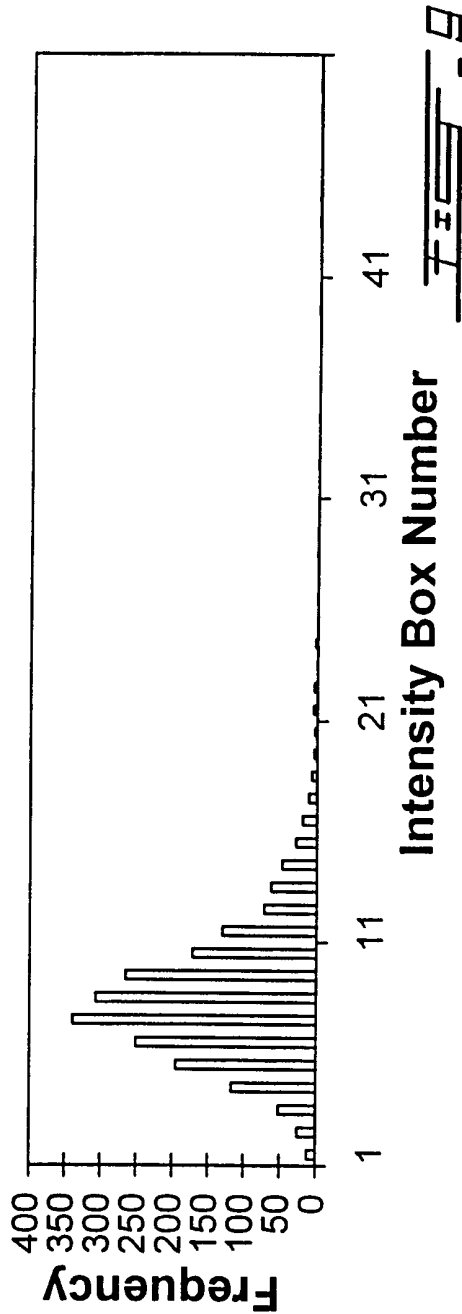
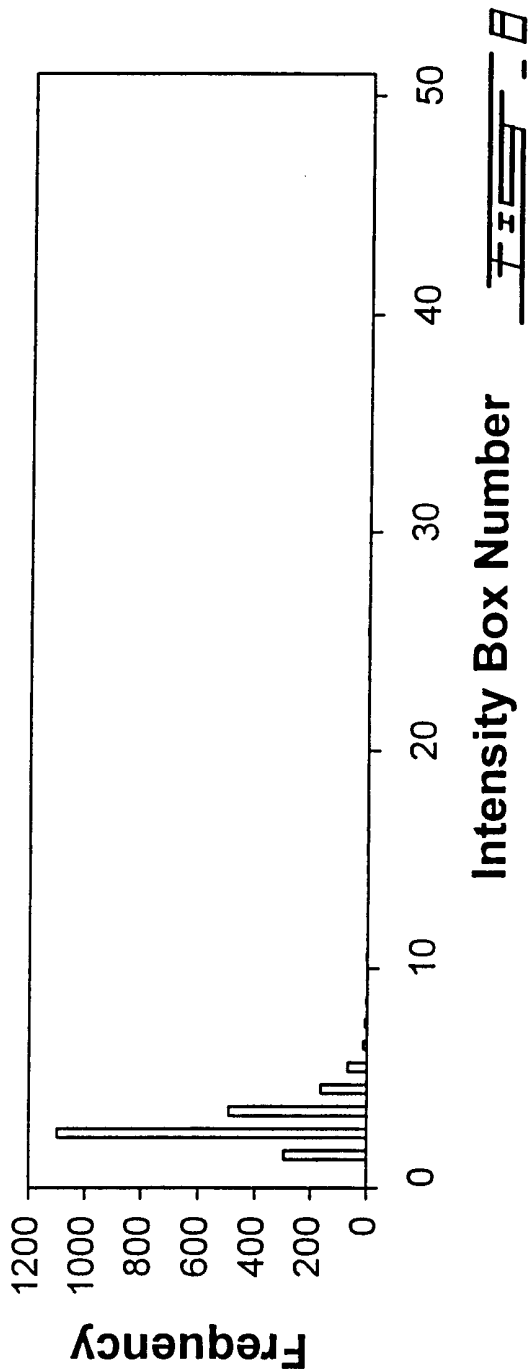
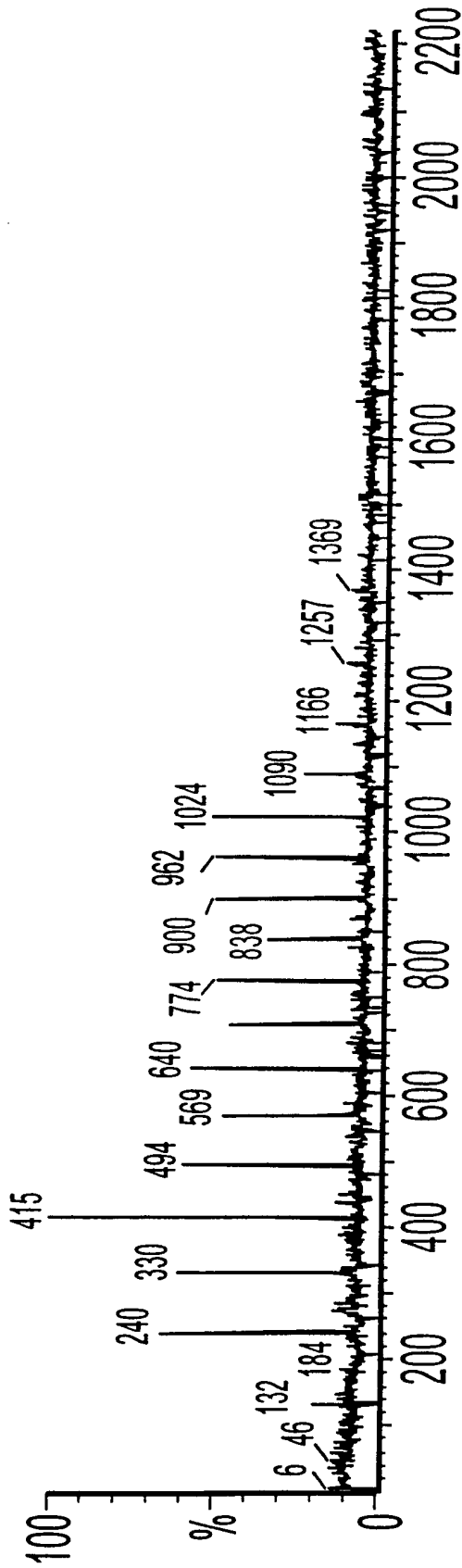

FIG. 7

5/12



6/12



FEES - 10A

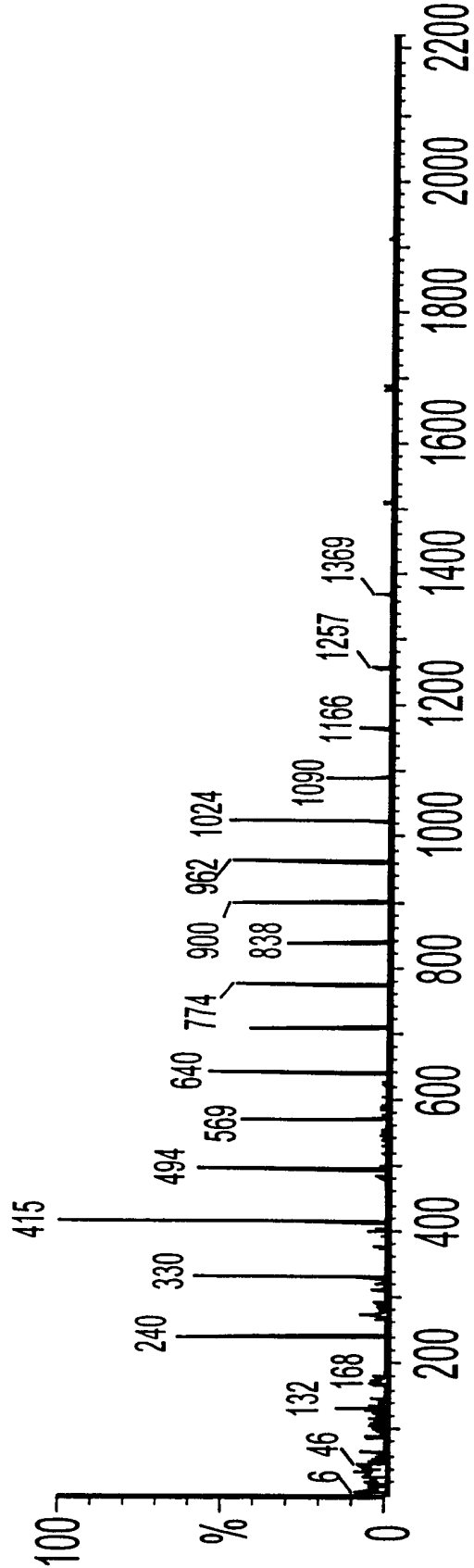

FEES - 10B

7/12

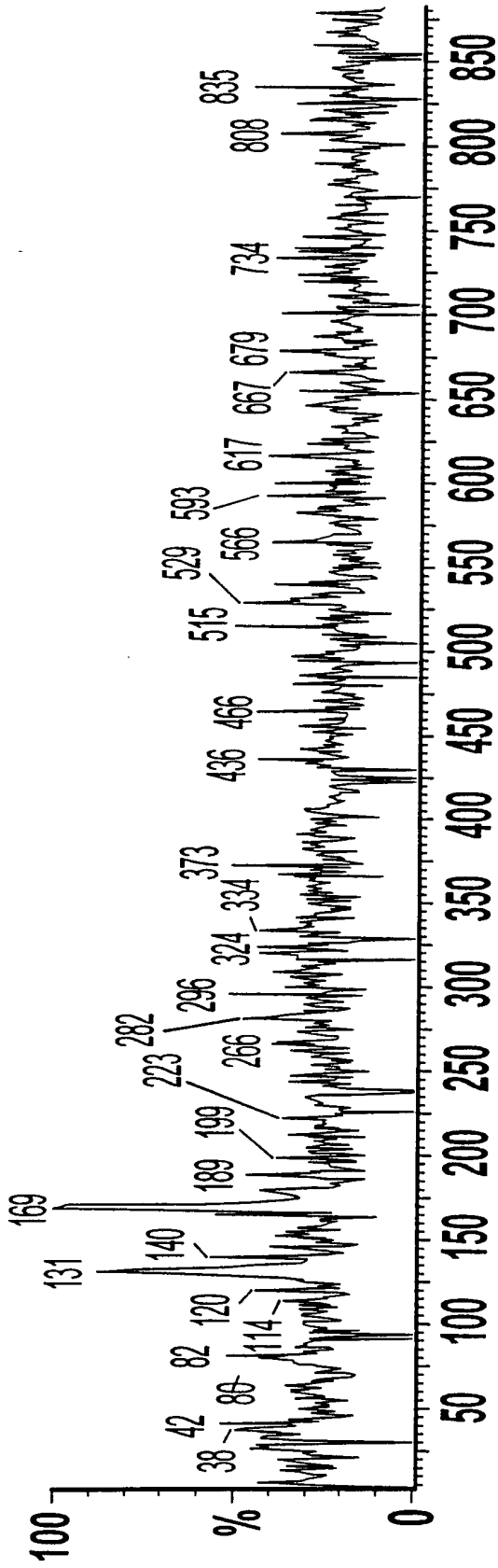

FEI - I I A

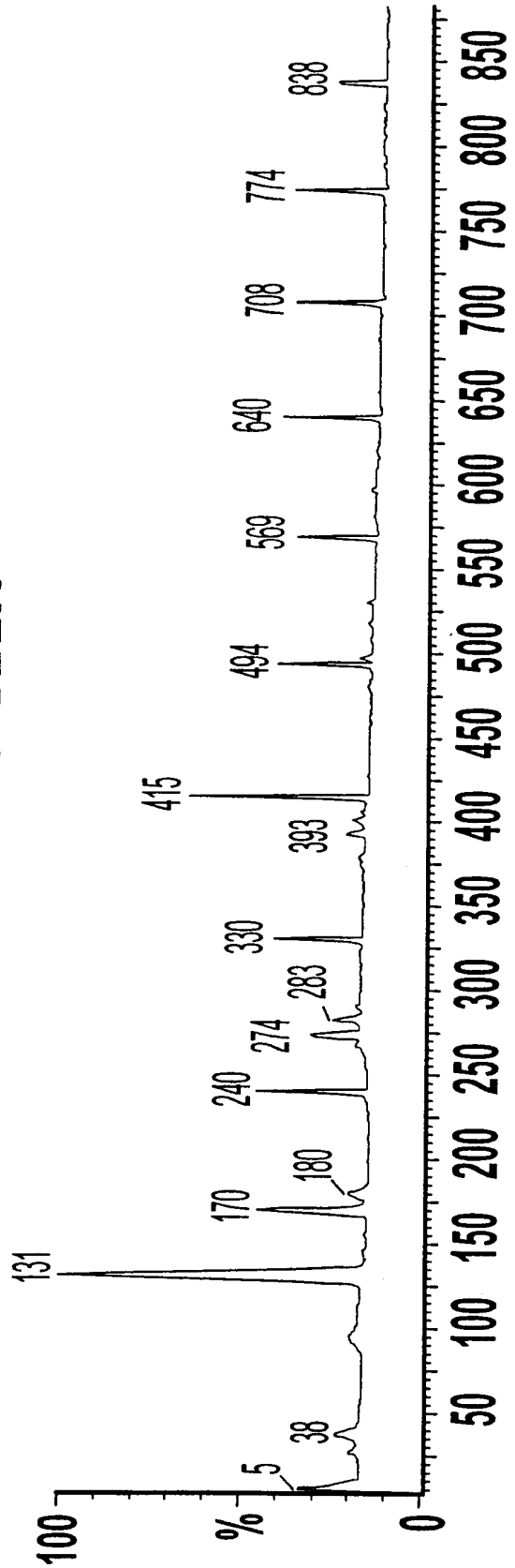

FEI - I I B

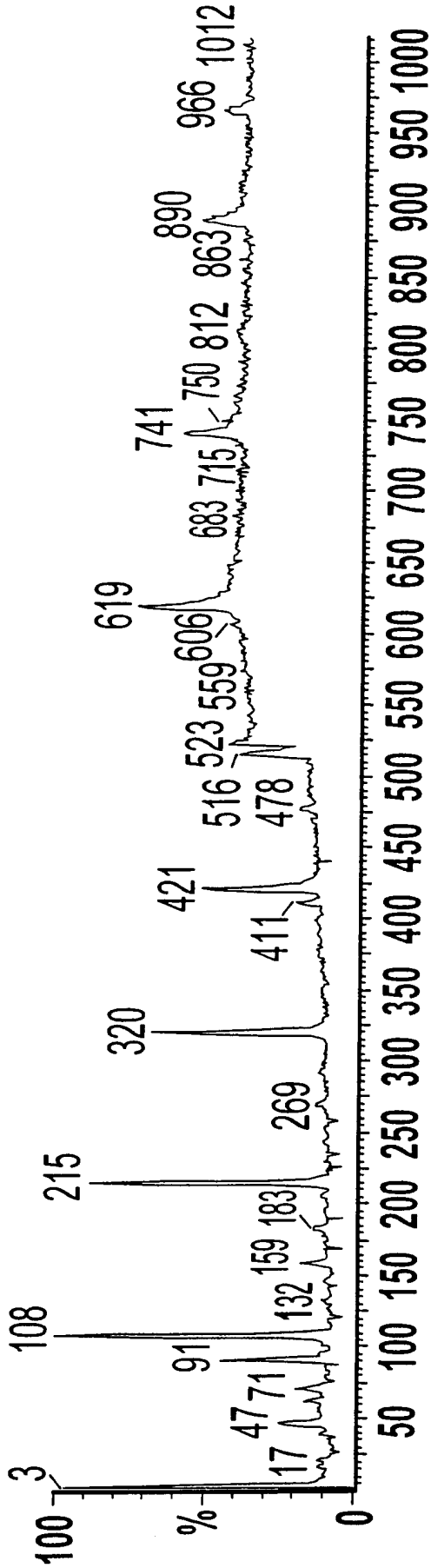

FEI - 12A

8/12

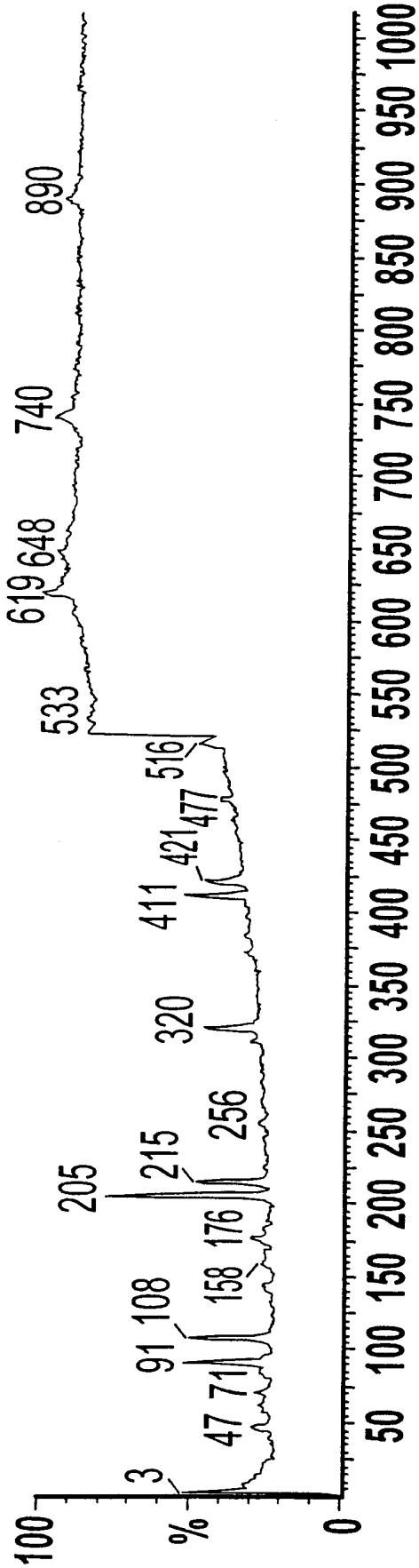

FEI - 12B

9/12

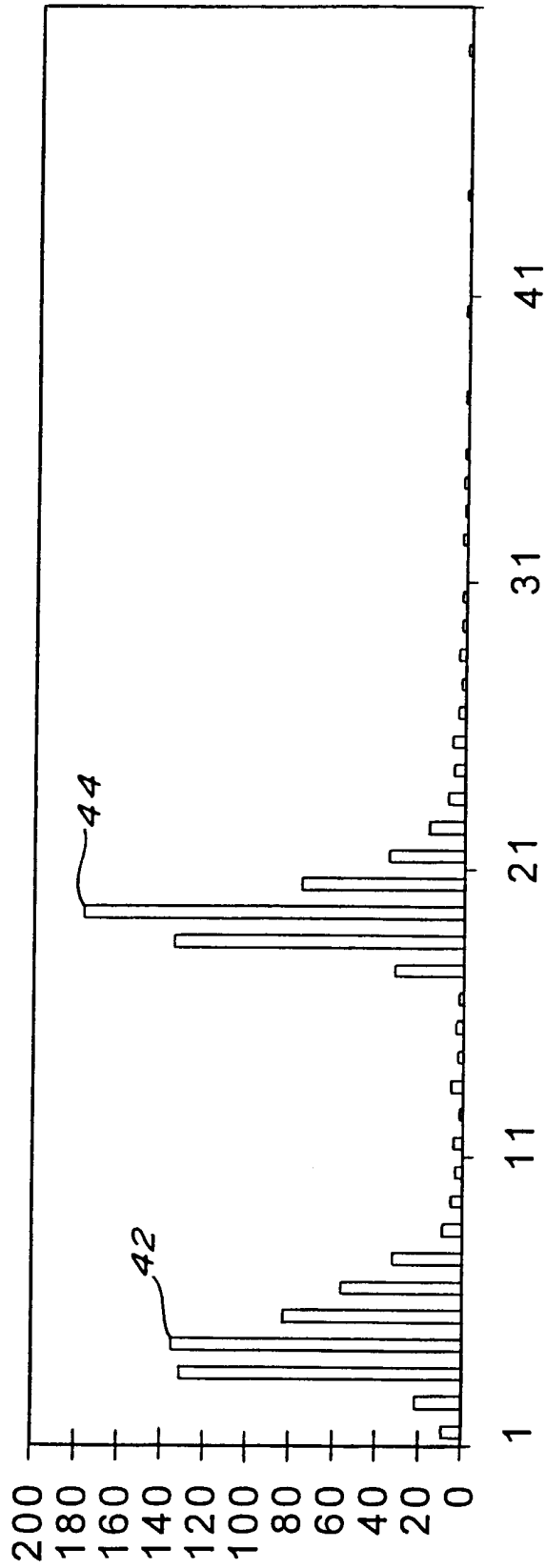

Intensity Box Number

FIG. 13

Frequency

10/12

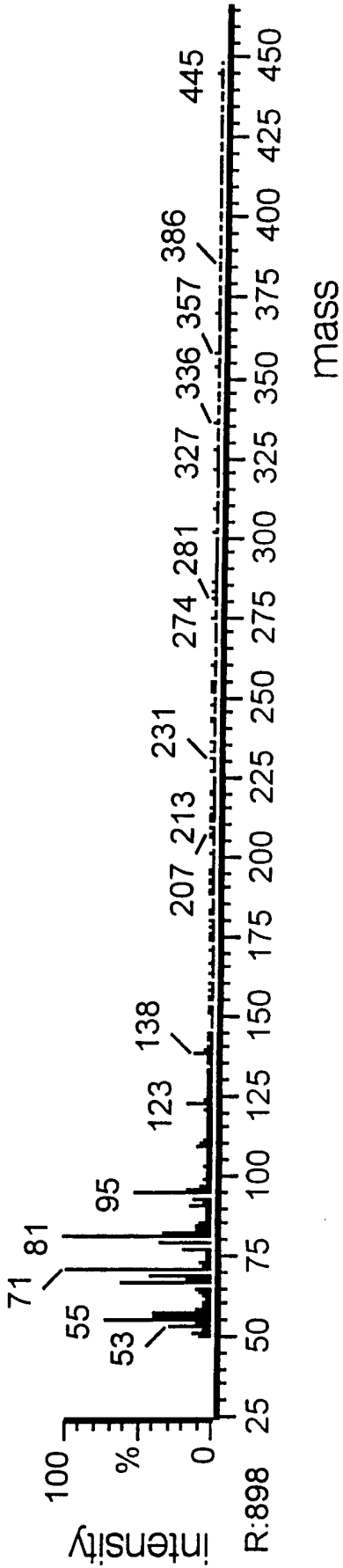

FEI-14A

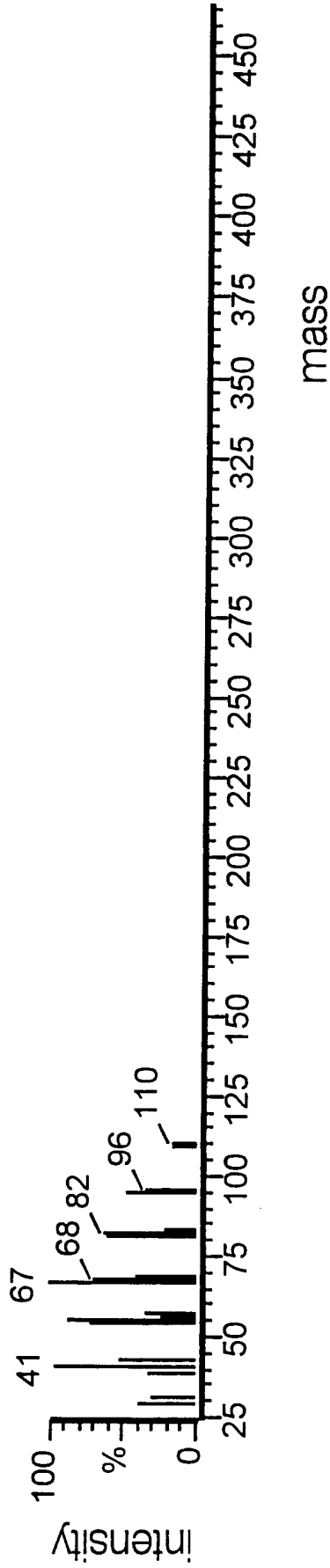

FEI-14B

11/12

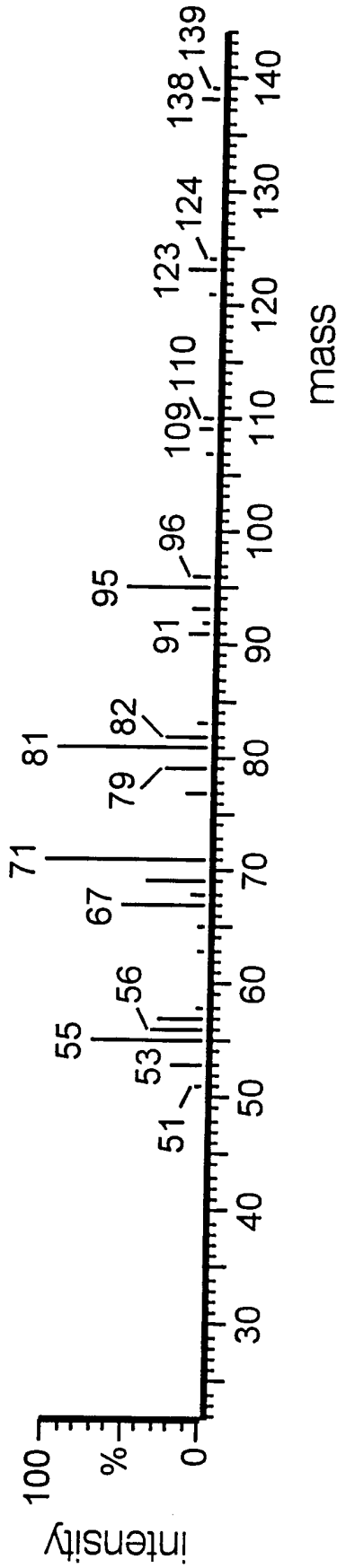

FILE - 15A

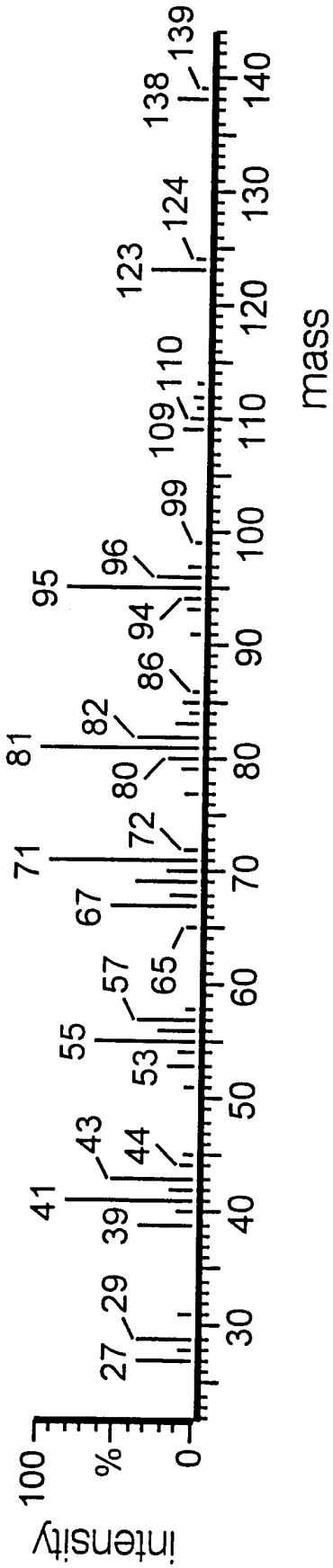

FILE - 15B

12 / 12

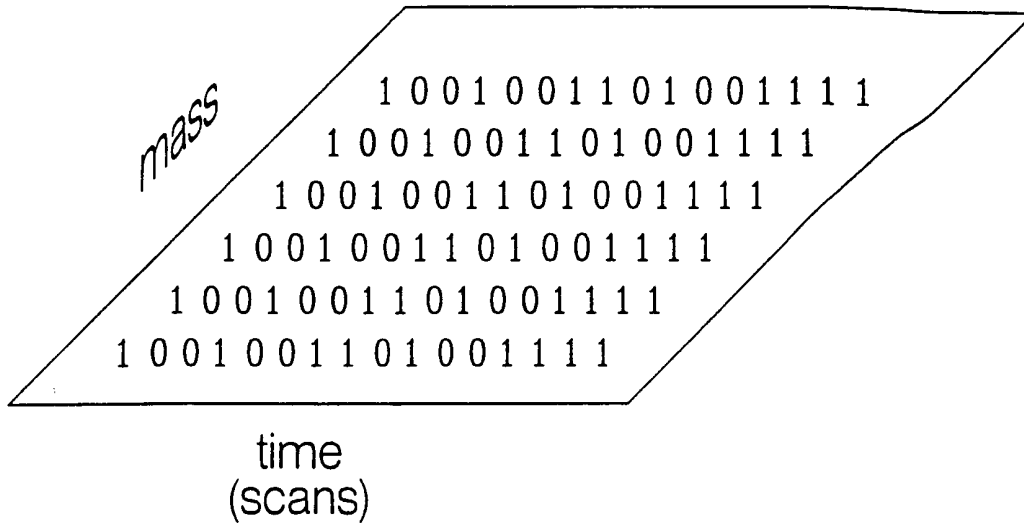

FIG. 16

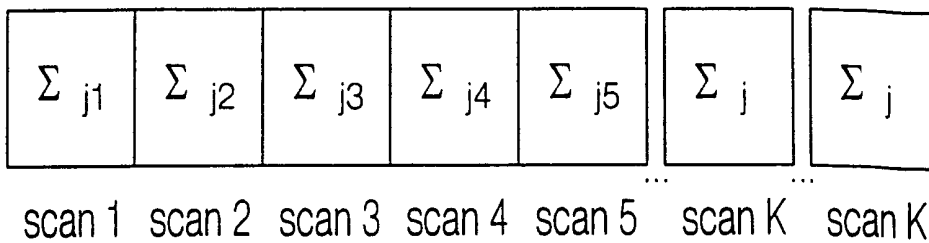

FIG. 17