

(19) World Intellectual Property Organization
International Bureau



(43) International Publication Date
18 March 2010 (18.03.2010)

(10) International Publication Number
WO 2010/030778 A1

(51) International Patent Classification:

A61B 17/04 (2006.01) A61B 17/10 (2006.01)
A61B 17/064 (2006.01) A61B 17/128 (2006.01)
A61B 17/08 (2006.01) A61B 17/00 (2006.01)

(21) International Application Number:

PCT/US2009/056512

(22) International Filing Date:

10 September 2009 (10.09.2009)

(25) Filing Language:

English

(26) Publication Language:

English

(30) Priority Data:

61/096,188 11 September 2008 (11.09.2008) US

(71) Applicant (for all designated States except US): **WILSON-COOK MEDICAL INC.** [US/US]; P.O. Box 27115-4191, 4900 Bethania Station Road, Winston-Salem, NC 27105-4191 (US).

(72) Inventors; and

(75) Inventors/Applicants (for US only): **KOCHMAN, Michael, L.** [US/US]; 3400 Spruce Street, Philadelphia, PA 19104 (US). **SURTI, Vihar, C.** [US/US]; 103 Cheswyck Lane, Winston-Salem, NC 27104 (US).

(74) Agent: **OGUSS, Douglas;** Brinks Hofer Gilson & Lione, P.O. Box 10087, Chicago, IL 60610 (US).

(81) Designated States (unless otherwise indicated, for every

kind of national protection available): AE, AG, AL, AM, AO, AT, AU, AZ, BA, BB, BG, BH, BR, BW, BY, BZ, CA, CH, CL, CN, CO, CR, CU, CZ, DE, DK, DM, DO, DZ, EC, EE, EG, ES, FI, GB, GD, GE, GH, GM, GT, HN, HR, HU, ID, IL, IN, IS, JP, KE, KG, KM, KN, KP, KR, KZ, LA, LC, LK, LR, LS, LT, LU, LY, MA, MD, ME, MG, MK, MN, MW, MX, MY, MZ, NA, NG, NI, NO, NZ, OM, PE, PG, PH, PL, PT, RO, RS, RU, SC, SD, SE, SG, SK, SL, SM, ST, SV, SY, TJ, TM, TN, TR, TT, TZ, UA, UG, US, UZ, VC, VN, ZA, ZM, ZW.

(84) Designated States (unless otherwise indicated, for every

kind of regional protection available): ARIPO (BW, GH, GM, KE, LS, MW, MZ, NA, SD, SL, SZ, TZ, UG, ZM, ZW), Eurasian (AM, AZ, BY, KG, KZ, MD, RU, TJ, TM), European (AT, BE, BG, CH, CY, CZ, DE, DK, EE, ES, FI, FR, GB, GR, HR, HU, IE, IS, IT, LT, LU, LV, MC, MK, MT, NL, NO, PL, PT, RO, SE, SI, SK, SM, TR), OAPI (BF, BJ, CF, CG, CI, CM, GA, GN, GQ, GW, ML, MR, NE, SN, TD, TG).

Published:

- with international search report (Art. 21(3))
- before the expiration of the time limit for amending the claims and to be republished in the event of receipt of amendments (Rule 48.2(h))

(54) Title: METHODS FOR ACHIEVING SEROSA-TO-SEROSA CLOSURE OF A BODILY OPENING USING ONE OR MORE TACKING DEVICES

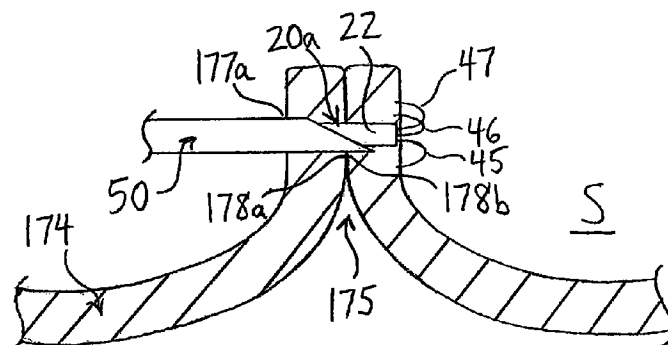

FIG. 15

(57) Abstract: The present embodiments provide methods for facilitating closure of a bodily opening. In one exemplary method, a compressive force is imposed upon first and second tissue segments that at least partially surround an opening in tissue. The first and second tissue segments are positioned in a manner where a first serosal tissue region of the first tissue segment is compressed against a second serosal tissue region of the second tissue segment to facilitate sealing of the opening. At least one tacking device having proximal and distal deployable members may be deployed using a suitable insertion tool to impose a compressive force to hold the first serosal tissue region in a sealing relationship against the second serosal tissue region.



WO 2010/030778 A1

METHODS FOR ACHIEVING SEROSA-TO-SEROSA CLOSURE OF A BODILY OPENING USING ONE OR MORE TACKING DEVICES

PRIORITY CLAIM

5 [0001] This invention claims the benefit of priority of U.S. Provisional Application Serial No. 61/096,188, entitled "Methods for Achieving Serosa-to-Serosa Closure of a Bodily Opening Using One or More Tacking Devices," filed September 11, 2008, the disclosure of which is hereby incorporated by reference in its entirety.

BACKGROUND

10 [0002] The present embodiments relate generally to medical devices, and more particularly, to methods for facilitating closure of a bodily opening.

[0003] Perforations in tissue or bodily walls may be formed intentionally or unintentionally. For example, an unintentional ventral abdominal hernia may be formed in the abdominal wall due to heavy lifting, coughing, strain imposed during a bowel movement or urination, fluid in
15 the abdominal cavity, or other reasons.

[0004] Intentional perforations may be formed, for example, during surgical procedures such as transluminal procedures. In a transluminal procedure, one or more instruments, such as an endoscope, may be inserted through a visceral wall, such as the stomach wall. During a transluminal procedure, a closure instrument may be used to close the perforation in the
20 visceral wall. Depending on the structure comprising the perforation, it may be difficult to adequately close the perforation and prevent leakage of bodily fluids.

[0005] Attempts to seal perforations have been attempted by coupling a graft member to tissue. For example, during hernia repair, a graft material such as a mesh or patch may be disposed to cover the perforation. The graft material may completely overlap with the
25 perforation, and the edges of the graft material may at least partially overlap with tissue surrounding the perforation. The graft material then may be secured to the surrounding tissue in an attempt to effectively cover and seal the perforation.

[0006] In order to secure the graft material to the surrounding tissue, sutures commonly are manually threaded through the full thickness of the surrounding tissue. In the case of a
30 ventral abdominal hernia, the sutures may be threaded through the thickness of the abdominal

wall, then tied down and knotted. However, such manual suturing techniques may be time consuming and/or difficult to perform.

[0007] Similarly, when closing intentional openings formed during transluminal procedures, suturing techniques may be used. However, the suturing techniques employed to close transluminal openings may be difficult to perform, may permit leakage of bodily fluids, and may be unreliable and difficult to reproduce.

SUMMARY

[0008] The present embodiments provide methods for facilitating closure of a bodily opening. In one exemplary method, a compressive force is imposed upon first and second tissue segments that at least partially surround an opening in tissue. The first and second tissue segments are positioned in a manner where a first serosal tissue region of the first tissue segment is compressed against a second serosal tissue region of the second tissue segment to facilitate sealing of the opening.

[0009] At least one tacking device having proximal and distal deployable members may be deployed using a suitable insertion tool to impose a compressive force to hold the first serosal tissue region in a sealing relationship against the second serosal tissue region. The proximal and distal deployable members each have contracted and expanded states, and may comprise hook-shaped configurations in the expanded states.

[0010] The tacking device may be delivered to a target site using an insertion tool comprising a hollow lumen having an inner diameter configured to receive the proximal and distal deployable members in the contracted state. In one exemplary technique, the insertion tool may be advanced through the first tissue segment in a direction from a first mucosal tissue region through the first serosal tissue region. The insertion tool then may be advanced through the second tissue segment in a direction from the second serosal tissue region through a second mucosal tissue region. At this time, the first and second serosal tissue regions may be positioned in close proximity or in an abutting relationship.

[0011] The insertion tool then may be retracted with respect to the tacking device to deploy the tacking device from the lumen of the insertion tool. In the expanded state, the proximal deployable members may engage the first mucosal tissue region and the distal deployable members may engage the second mucosal tissue region. Further, the proximal and distal

deployable members of the tacking device may apply a compressive force in the expanded state to hold the first and second tissue segments together and facilitate sealing of the opening.

[0012] Other systems, methods, features and advantages of the invention will be, or will become, apparent to one with skill in the art upon examination of the following figures and detailed description. It is intended that all such additional systems, methods, features and advantages be within the scope of the invention, and be encompassed by the following claims.

BRIEF DESCRIPTION OF THE DRAWINGS

[0013] The invention can be better understood with reference to the following drawings and description. The components in the figures are not necessarily to scale, emphasis instead being placed upon illustrating the principles of the invention. Moreover, in the figures, like referenced numerals designate corresponding parts throughout the different views.

[0014] FIG. 1 is a perspective view of a tacking device.

[0015] FIG. 2 is a perspective view of a distal region of an insertion tool and the tacking device of FIG. 1.

[0016] FIG. 3 is a perspective, cut-away view illustrating multiple tacking devices in a delivery configuration.

[0017] FIG. 4 is a schematic view illustrating a ventral hernia.

[0018] FIG. 5 is a schematic view illustrating a graft member used to cover the ventral hernia of FIG. 4.

[0019] FIG. 6 is a schematic view of a method step for treating the ventral hernia of FIG. 4.

[0020] FIG. 7 is a side-sectional view taken along line A--A of FIG. 6.

[0021] FIG. 8 is a side-sectional view showing multiple tacking devices deployed in expanded configurations.

[0022] FIG. 9 is a schematic view illustrating multiple deployed tacking devices used to treat the ventral hernia of FIG. 4.

[0023] FIG. 10 is a perspective view of an alternative tacking device.

[0024] FIG. 11 is a side-sectional view illustrating one method of use of multiple tacking devices of FIG. 10.

[0025] FIG. 12 is a side-sectional view depicting an opening in the stomach.

[0026] FIGS. 13-16 are exemplary methods steps that may be used to seal the opening of FIG. 12, with an insertion tool and tacking device shown from a side view and the stomach wall shown in a side-section view for illustrative purposes.

5 DETAILED DESCRIPTION OF THE PREFERRED EMBODIMENTS

[0027] In the present application, the term “proximal” refers to a direction that is generally towards a physician during a medical procedure, while the term “distal” refers to a direction that is generally towards a target site within a patient’s anatomy during a medical procedure.

[0028] Referring now to FIG. 1, a first embodiment of a tacking device 20 is shown. In this
10 embodiment, the tacking device 20 comprises at least one tube member 22 having a proximal end 24 and a distal end 26. The tacking device 20 further comprises a proximal deployment mechanism 32 and a distal deployment mechanism 42. In the embodiment of FIG. 1, the proximal deployment mechanism 32 comprises three proximal deployable members 35-37, while the distal deployment mechanism 42 comprises three distal deployable members 45-47.
15 The proximal deployable members 35-37 extend proximally from the proximal end 24 of the tube member 22, while the distal deployable members 45-47 extend distally from the distal end 26 of the tube member 22, as shown in FIG. 1. In the embodiment of FIG. 1, since the device is symmetrical, it may be loaded into an insertion tool with either end first, as explained further below.

[0029] The proximal deployable members 35-37 and the distal deployable members 45-47
20 each may be affixed relative to the tube member 22. In one embodiment, each of the proximal and distal deployable members 35-37 and 45-47 may be separate and discrete elements. Accordingly, six separate deployable members may be provided. Specifically, the three proximal deployable members 35-37 may be coupled to the tube member 22 near the
25 proximal end 24 of the tube member 22. The three proximal deployable members 35-37 may be coupled to the proximal end 24 of the tube member 22 using an adhesive, frictional fit, mechanical device or other suitable mechanism or processes. Similarly, the three distal deployable members 45-47 may be coupled to the distal end 26 of the tube member 22 using an adhesive, frictional fit, mechanical device or other suitable mechanism.

[0030] In an alternative embodiment, instead of providing six discrete deployable members, three wires may be disposed through the entirety of tube member 22. In this embodiment, a first wire may comprise a proximal end that forms the deployable member 35 and a distal end that forms the deployable member 45, while a central region of the same wire is disposed through the entirety of the tube member 22. Similarly, second and third wires may be disposed through the entirety of the tube member 22 to form the remaining proximal and distal deployable members. In this embodiment, the three wires that extend through the length of the tube member 22 may be affixed to an interior surface of the tube member 22, for example, using an adhesive or mechanical device. The three wires also may be sized to create a frictional fit against each other and/or an interior surface of the tube member 22, thereby inhibiting movement of the proximal and distal deployable members 35-37 and 45-47 in longitudinal directions with respect to the tube member 22.

[0031] While six total deployable members 35-37 and 45-47 are depicted, including three at both the proximal and distal ends of the tacking device 20, it will be apparent that greater or fewer deployable members may be employed. Moreover, the deployable members 35-37 and 45-47 may comprise any shape suitable for engaging, penetrating and/or abutting tissue, for purposes explained further below, and need not necessarily assume the expanded shape depicted in FIGS. 1-2.

[0032] The tube member 22 may comprise any suitable shape and material. Solely by way of example, the tube member 22 may comprise stainless steel or a biocompatible plastic. The tube member 22 may be cylindrically-shaped, as depicted in FIG. 1, which may facilitate insertion through a lumen of an insertion tool 50. Further, the tube member 22 may comprise one solid tube, or alternatively may comprise one or more tubes that may comprise slots, holes, cut-out regions and the like, for example, as shown and explained below with respect to the embodiment of FIGS. 10-11.

[0033] Alternatively, as explained further below with respect to FIG. 10, the tube member 22 may be omitted entirely in the case where a first wire 125 integrally forms the proximal and distal deployable members 135 and 145, a second wire 126 integrally forms the proximal and distal deployable members 136 and 146, and a third wire 127 integrally forms the proximal and distal deployable members 137 and 147. In the latter embodiment, central regions of the first, second and third wires 125-127 may be affixed together, for example, using a solder or weld, to maintain the structural rigidity of the components.

[0034] Referring still to FIGS. 1-3, the proximal and distal deployable members 35-37 and 45-47 each comprise a contracted delivery configuration, as shown in FIG. 3 below, and further comprise an expanded deployed configuration, as shown in FIG. 1. In one embodiment, each of the deployable members 35-37 and 45-47 may comprise a hook-shaped configuration in the expanded state. For example, the deployable members 35-37 and 45-47 may comprise a curvature of about 90 to about 360 degrees in the expanded state, and more preferably about 180 degrees, as shown in FIGS. 1-2. Where the deployable members 35-37 and 45-47 “retroflex” and comprises a curvature of about 180 degrees, the end regions 39 and 49 of the proximal and distal deployable members are oriented substantially parallel to the tube member 22. Moreover, the end regions 39 and 49 may be radially spaced apart from one another in the expanded state, as shown in FIG. 1. In this configuration, the end regions 39 and 49 may be well-suited for engaging, grasping, piercing and/or abutting tissue or graft material.

[0035] Further, a longitudinal distance L_1 between the end regions 39 and 49 of the tacking device 20 may be varied to engage tissue in a desirable manner. For example, the longitudinal distance L_1 may be dimensioned to be substantially equal to or less than the combined thickness t_1 and t_2 of a tissue 74 and a graft member 80, respectively, as shown in FIG. 8 below, thereby providing a desired compressive force upon the tissue 74 and the graft member 80.

[0036] The dimension of the tacking device 20 may be tailored based on a particular surgical procedure, a particular patient’s anatomy and/or other factors. However, for illustrative purposes, in a ventral hernia repair operation, the longitudinal length of the tube member 22 may range from about 2mm to about 10mm, the straightened (delivery or non-curved) length of the proximal deployable members 35-37 may range from about 5mm to about 50mm, the straightened (delivery or non-curved) length of the distal deployable members 45-47 may range from about 5mm to about 50mm, the longitudinal distance L_1 between the end regions 39 and 49 may range from about 5mm to about 30mm, the outer diameter of the tube member 22 may range from about 0.3mm to about 1.5mm, and the outer diameter of the deployable member 35-37 and 45-47 may range from about 0.1mm to about 0.5mm. Such dimensions are provided for reference purposes only and are not intended to be limiting.

[0037] The deployable members 35-37 and 45-47 may comprise a shape-memory material, such as a nickel-titanium alloy (nitinol). If a shape-memory material such as nitinol is

employed, the deployable members 35-37 and 45-47 may be manufactured such that they can assume the preconfigured expanded state shown in FIG. 1 upon application of a certain cold or hot medium. More specifically, a shape-memory material may undergo a substantially reversible phase transformation that allows it to “remember” and return to a previous shape or configuration. For example, in the case of nitinol, a transformation between an austenitic phase and a martensitic phase may occur by cooling and/or heating (shape memory effect) or by isothermally applying and/or removing stress (superelastic effect). Austenite is characteristically the stronger phase and martensite is the more easily deformable phase.

[0038] In an example of the shape-memory effect, a nickel-titanium alloy having an initial configuration in the austenitic phase may be cooled below a transformation temperature (M_f) to the martensitic phase and then deformed to a second configuration. Upon heating to another transformation temperature (A_f), the material may spontaneously return to its initial, predetermined configuration, as shown in FIG. 1. Generally, the memory effect is one-way, which means that the spontaneous change from one configuration to another occurs only upon heating. However, it is possible to obtain a two-way shape memory effect, in which a shape memory material spontaneously changes shape upon cooling as well as upon heating.

[0039] Alternatively, the deployable members 35-37 and 45-47 may be made from other metals and alloys that are biased, such that they may be restrained by the insertion tool 50 prior to deployment, but are inclined to return to their relaxed, expanded configuration upon deployment. Solely by way of example, the deployable members 35-37 and 45-47 may comprise other materials such as stainless steel, cobalt-chrome alloys, amorphous metals, tantalum, platinum, gold and titanium. The deployable members 35-37 and 45-47 also may be made from non-metallic materials, such as thermoplastics and other polymers. As noted above, the deployable members 35-37 and 45-47 may comprise any shape suitable for engaging, penetrating and/or abutting tissue, for purposes explained further below, and need not necessarily assume the curved shape depicted in FIGS. 1-2.

[0040] Referring to FIGS. 2-3, one or more tacking devices 20 may be delivered to a target site in a patient's anatomy using an insertion tool 50. In one embodiment, the insertion tool 50 is capable of carrying multiple different tacking devices, such as six tacking devices 20a-20f, as shown in FIG. 9 and described below. In FIG. 3, one complete tacking device 20a is shown in the contracted state, while portions of the proximal deployment mechanism 42b of

another tacking device 20b, and the distal deployment mechanism 32f of another tacking device 20f, are also shown.

[0041] In one embodiment, the insertion tool 50 comprises a needle-like body having a sharpened distal tip 52 and a hollow lumen 54, as shown in FIGS. 2-3. The insertion tool 50 may be manufactured from stainless steel or any other suitable material, and may comprise an endoscopic ultrasound (EUS), or echogenic, needle. Solely by way of example, the insertion tool 50 may comprise the EchoTip® Ultrasound Needle, or the EchoTip® Ultra Endoscopic Ultrasound Needle, both manufactured by Cook Endoscopy of Winston-Salem, N.C.

[0042] The hollow lumen 54 of the insertion tool 50 may comprise an inner diameter that is larger than an outer diameter of the tacking device 20. Therefore, one or more tacking devices, such as six tacking devices 20a-20f, may be loaded into the hollow lumen 54 in a delivery configuration, as shown in FIG. 3. In the delivery configuration, the proximal and distal deployable members 35-37 and 45-47 of each tacking device 20a-20f may comprise a substantially longitudinally-oriented profile, i.e., oriented along a longitudinal axis of the insertion tool 50.

[0043] The multiple tacking devices 20a-20f may be inserted into the hollow lumen 54 of the insertion tool 50 in a sequential manner, whereby the proximal deployment mechanism 32a of the first tacking device 20a may abut the distal deployment mechanism 42b of the second tacking device 20b, as depicted in FIG. 3. The distal deployment mechanism 42a of the first tacking device 20a may be loaded a distance away from the sharpened distal tip 52 of the insertion tool 50 to prevent inadvertent deployment.

[0044] A stylet 60 may be disposed for longitudinal movement within the hollow lumen 52 of the insertion tool 50, as shown in FIG. 3. The stylet 60 may comprise stainless steel or any other suitable material. The stylet 60 is disposed proximal to the proximal deployment mechanism 32f of the final sequential tacking device 20f, as shown in FIG. 3. During use, the insertion tool 50 may be proximally retracted, while the stylet 60 may be held longitudinally steady, to facilitate sequential deployment of each of the tacking devices 20a-20f, as explained further below.

[0045] The insertion tool 50 may comprise one or more markers 56, as shown in FIGS. 2-3, which may be disposed near the distal end of the insertion tool 50. The markers 56 may be configured to be visualized under fluoroscopy or other imaging techniques to facilitate location of the distal end of the insertion tool, for example, so that a physician may determine

how far the insertion tool 50 has penetrated into tissue 74, as depicted in FIGS. 7-8. Optionally, a sheath member 58 having an inner diameter larger than an outer diameter of the insertion tool 50, as shown in FIG. 2, may be longitudinally advanced over the insertion tool 50, for various purposes explained further below. As will be explained further below, the insertion tool 50 may be used in conjunction with another device, such as an endoscope, and may be delivered through a working lumen of an endoscope or similar device.

[0046] Referring now to FIGS. 4-9, one or more tacking devices 20 described above may be used to facilitate treatment of a perforation 75 using a graft member 80. In the example shown, the perforation 75 is a ventral hernia located in the abdominal wall 74. The right and left legs 72 and 73 of a patient 70 are shown for illustrative purposes. While treatment of a ventral hernia is shown for illustrative purposes, it will be apparent that the tacking devices described herein may be used in a wide range of medical procedures, including but not limited to any exemplary procedures described herein.

[0047] The initial stages of the ventral hernia repair may be performed using techniques that are known. Specifically, an open technique or laparoscopic technique may be employed. In an open technique, an incision may be made in the abdominal wall and fat and scar tissue may be removed from the area. A graft member 80 then may be applied so that it overlaps the perforation 75, preferably by several millimeters or centimeters in each direction, as depicted in FIG. 5. In a laparoscopic technique, two or three smaller incisions may be made to access the hernia site. A laparoscope may be inserted into one incision, and surgical instruments may be inserted into the other incision(s) to remove tissue and place the graft member 80 in the same position as the open procedure.

[0048] The graft member 80 may comprise any suitable material for covering the perforation 75 and substantially or entirely inhibiting the protrusion of abdominal matter. In one embodiment, the graft member 80 may comprise small intestinal submucosa (SIS), such as SURGISIS® BIODESIGN™ Soft Tissue Graft, available from Cook Biotech, Inc., West Lafayette, Indiana, which provides smart tissue remodeling through its three-dimensional extracellular matrix (ECM) that is colonized by host tissue cells and blood vessels, and provides a scaffold for connective and epithelial tissue growth and differentiation along with the ECM components. Preferably, the graft member 80 would be a one to four layer lyophilized soft tissue graft made from any number of tissue engineered products. Reconstituted or naturally-derived collagenous materials can be used, and such materials that

are at least bioresorbable will provide an advantage, with materials that are bioremodelable and promote cellular invasion and ingrowth providing particular advantage. Suitable bioremodelable materials can be provided by collagenous ECMs possessing biotropic properties, including in certain forms angiogenic collagenous extracellular matrix materials.

5 For example, suitable collagenous materials include ECMs such as submucosa, renal capsule membrane, dermal collagen, dura mater, pericardium, fascia lata, serosa, peritoneum or basement membrane layers, including liver basement membrane. Suitable submucosa materials for these purposes include, for instance, intestinal submucosa, including small intestinal submucosa, stomach submucosa, urinary bladder submucosa, and uterine
10 submucosa. The graft member 80 may also comprise a composite of a biomaterial and a biodegradable polymer. Additional details may be found in U.S. Patent No. 6,206,931 to Cook et al., the disclosure of which is incorporated herein by reference in its entirety.

[0049] Referring now to FIGS. 6-7, after the graft member 80 has been placed to cover the perforation 75, the insertion tool 50 may be advanced in a distal direction to pierce through
15 the graft member 80, and further may pierce at least partially into the tissue 74 at a first location around the perimeter of the perforation 75. In this example, the insertion tool 50 is carrying six sequential tacking devices 20a-20f, which may be disposed within the hollow lumen 54 of the insertion tool 50 as shown and explained with respect to FIG. 3 above. With each of the tacking devices 20a-20f in the contracted delivery states, the sharpened tip 52 of
20 the insertion tool 50 may be advanced to a predetermined depth into the tissue 74. The markers 56 of FIGS. 2-3 may facilitate in determining how far the insertion tool 50 has penetrated into tissue 74, as depicted in FIG. 7.

[0050] In a next step, the stylet 60 of FIG. 3 may be held steady with respect to the insertion tool 50, while the insertion tool 50 is retracted in a proximal direction. This causes the distal
25 deployable members 45-47 of the most distal tacking device 20a to extend distal to the sharpened tip 52 of the insertion tool 50, as depicted in FIG. 7. When the distal deployable members 45-47 are no longer radially constrained by the insertion tool 50, they may assume their predetermined expanded configurations in which they may engage, penetrate and/or abut the tissue 74. As the insertion tool 50 further is retracted proximally with respect to the
30 tacking device 20a, the proximal deployable members 35-37 may assume their predetermined expanded configuration when are no longer radially constrained, as shown in FIG. 7. In the expanded configuration, the proximal deployable members 35-37 may engage, penetrate

and/or abut the graft member 80 and optionally penetrate into the tissue 74. In this manner, the tacking device 20a helps secure the graft material 80 against the tissue 74. In particular, the substantially 180-degree hook-shaped configuration of the proximal deployable members 35-37 may urge the graft member 80 in a distal direction towards the tissue 74.

5 [0051] After the first tacking device 20a has been deployed, the insertion tool 50 may be repositioned to deploy another tacking device around the perimeter of the perforation 75. Each subsequent tacking device 20b-20f may be deployed in the same manner as the tacking device 20a. In this manner, the tacking devices 20a-20f may secure the graft member 80 around the perimeter of the perforation 75, as shown in FIG. 9. As will be apparent, greater
10 or fewer tacking devices may be used, and the positioning of the tacking devices may be varied to optimize securing the graft member 80 to the tissue 74 in order to substantially seal the perforation 75.

[0052] Optionally, the sheath member 58 of FIG. 2 may be longitudinally advanced over the insertion tool 50, for example, if needed to protect the sharpened distal tip 52 of the insertion
15 tool 50 while the insertion tool 50 is being repositioned. Further, the sheath member 58 may be advanced distally over the insertion tool 50 to facilitate deployment of the proximal deployable members 35-37. For example, the sheath member 58 may periodically push against the graft member 80, thereby temporarily urging the graft member 80 and/or the tissue 74 in a distal direction. At this time, the sheath member 58 may be held steady while
20 the insertion tool 50 is retracted proximally to deploy the proximal deployable members 35-37 at a location proximal to the compressed tissue 74 and graft member 80. Once the proximal deployable members 35-37 have been deployed, the compressive force applied by the sheath member 58 may be removed so that the graft member 80 and the tissue 74 may engage the deployed proximal deployable members 35-37.

25 [0053] In the embodiment of FIGS. 4-9, the tissue 74 illustratively comprises a thickness t_1 , while the graft member 80 comprises a thickness t_2 . The distal deployable members 45-47 may be deployed entirely within the tissue 74, as depicted in FIG. 8, or alternatively may be deployed substantially distal to the tissue 74 while abutting or piercing through a distal edge of the tissue 74. In the latter embodiment, the longitudinal distance L_1 between the end
30 regions 39 and 49 of the tacking device 20 may be dimensioned to be substantially equal to, or slightly less than, the combined thickness $t_1 + t_2$ of the tissue 74 and the graft member 80.

The longitudinal distance L_1 may be otherwise sized and configured, as desired, to apply desired forces upon the graft member 80 and the tissue 74.

[0054] While FIGS. 4-9 have illustrated the use of one or more tacking device 20 for covering a perforation 75 formed in the ventral abdominal wall, the tacking devices disclosed herein may be useful in many other procedures. Solely by way of example, one or more tacking devices 20 may be used to treat perforations in a visceral wall, such as the stomach wall. In such cases, a suitable insertion device, such as an endoscope, may be advanced through a bodily lumen such as the alimentary canal to a position proximate the target location. One or more components may be advanced through a working lumen of the endoscope. To close the perforation, the graft member 80 may cover the perforation and may be secured in a position overlapping the perforation using the one or more of the tacking devices 20, which may be deployed using the techniques described hereinabove.

[0055] Referring now to FIG. 10, in an alternative embodiment, a tacking device 120 may comprise one or more features for facilitating suturing, and preferably purse-string suturing.

The tacking device 120 is similar to the tacking device 20 of FIG. 1, except as noted below. The tacking device 120 comprises proximal and distal deployable members 135-137 and 145-147, respectively. In this embodiment, the tacking device 120 comprises a proximal tube portion 122 and distal tube portion 123 with an opening, slot or cutout disposed therebetween, as shown in FIG. 10. First, second and third wires 125-127 may be disposed through the entirety of the proximal and distal tube portions 122 and 123, as depicted in FIG. 10.

[0056] The first wire 125 may comprise a proximal end that forms deployable member 135 and a distal end that forms deployable member 145, such that a central region of the first wire 125 is disposed through both tube portions 122 and 123. Similarly, the second and third wires 126 and 127 may be disposed through the entirety of the tube portions 122 and 123. The second wire 126 may comprise a proximal end that forms deployable member 136 and a distal end that forms deployable member 146, while the third wire 127 may comprise a proximal end that forms deployable member 137 and a distal end that forms deployable member 147. The three wires 125-127 may be affixed to an interior surface of the tube portions 122 and 123, for example, using an adhesive, frictional fit or mechanical device. Alternatively, the tube portions 122 and 123 may be omitted, and central regions of the first,

second and third wires 125-127 may be affixed to one another, for example, using a solder or weld.

[0057] In the embodiment shown, the second wire 126 comprises a loop member 150, which may be formed by bending a central region of the wire that is disposed between the tube portions 122 and 123, as shown in FIG. 10. The second wire 126 may be bent to form an arch-shaped loop member 150 having an aperture 152. A suture 160 may be threaded through the aperture 152 of the loop member 150, for example, as shown in FIG. 11 below.

[0058] In alternative embodiments, one single tube member may be employed, in lieu of the proximal and distal tube portions 122 and 123, and the single tube member may comprise a slot or cutout, such that the loop member 150 may extend radially through the slot or cutout. There also may be a single strip of material connecting the proximal and distal tube portions 122 and 123. Further, the loop member 150 need not be formed integrally from any of the wires 125-127, but rather may be formed as a loop disposed on an exterior surface of the proximal and distal tube portions 122 and 123, or on an exterior surface of a single tube member if only one tube is used. Still further, while the loop member 150 is shown in a substantially central location, it may be placed closer to the proximal or distal ends of the tacking device 120.

[0059] Referring now to FIG. 11, an exemplary method of using the tacking device 120 is shown. In one step, a graft member 80 may be placed over a perforation 75, and multiple tacking devices 120 may be deployed using an insertion device to secure the graft member 80 to the tissue 74, as explained in detail above with respect to FIGS. 4-9. In the embodiment of FIG. 11, multiple tacking devices 120 may be linked together by a single suture 160, which may be slidably coupled through the loop members 150 of each of the tacking devices 120, as generally shown in FIG. 11. There are two free ends 161 and 162 of the suture 160, which may be independently tensioned to facilitate closure of the perforation 75.

[0060] Preferably, multiple tacking devices 120 having loop members 150 are sequentially positioned around the perforation 75 in a semi-annular or annular shape, for example, as shown above in FIG. 9. The ends 161 and 162 of the suture 160 are then tensioned to reduce the distance between the tacking devices and compress the tissue 74 around the perforation 75. The suture ends 161 and 162 may be secured to maintain the compression of the tissue 74 using any suitable technique such as by forming a knot or using clamps, rivets and the like.

[0061] Further, in lieu of the loop members 150 described herein, other mechanisms for engaging and/or retaining sutures may be integrally formed with the tacking device 120 or externally attached thereto. Solely by way of example, such suture retaining mechanisms are explained in pending U.S. patent application Serial No. 11/946,565, filed November 28, 5 2007, the entire disclosure of which is hereby incorporated by reference in its entirety.

[0062] Various types of sutures 160 may be used in conjunction with embodiment of FIGS. 10-11. For example, synthetic sutures may be made from polypropylene, nylon, polyamide, polyethylene, and polyesters such as polyethylene terephthalate. These materials may be used as monofilament suture strands, or as multifilament strands in a braided, twisted or other 10 multifilament construction.

[0063] While the examples shown above have illustratively described a tacking device that may be useful for coupling a graft member to tissue to cover and seal a perforation, the tacking devices 20 and 120 also may be used in other procedures. For example, the tacking devices 20 and 120 may be used to secure a graft member to tissue for reconstructing local 15 tissue, and the like. Further, the tacking devices 20 and 120 may be used in an anastomosis procedure. In order to create an anastomosis, for example, multiple tacking devices 20 or 120 may be deployed in a circular manner to couple a proximal vessel, duct or organ to a distal vessel, duct or organ. In such cases, a suitable insertion device, such as an endoscope, may be advanced through a bodily lumen such as the alimentary canal to a position proximate the 20 target location. One or more components, such as the insertion tool 50, may be advanced through a working lumen of the endoscope. The distal end of the insertion tool 50 may be viewed under fluoroscopy, or via optical elements of the endoscope, or by some other visualization technique. Under suitable visualization, multiple tacking devices then may be delivered at one time, for example, using the insertion tool 50. Then, a hole may be punched 25 through the middle of the deployed tacking devices to create a flow path between the proximal and distal vessels/ducts/organs. It will be apparent that still further applications of the tacking devices 20 and 120 are possible. Moreover, the insertion tool 50 may be used with or without an endoscope or similar device.

[0064] Referring now to FIGS. 12-16, another exemplary use of the tacking device 20 is 30 described. In FIGS. 12-16, one or more tacking devices 20 are used for facilitating closure of an opening 175 in tissue 174. The tissue 174 generally comprises a mucosal layer 177 and a serosal layer 178. By way of example, the opening 175 may be formed during a transluminal

procedure, whereby the tissue 174 may comprise tissue of the stomach S, as depicted in FIG. 12, or alternatively tissue of the small or large intestines or another bodily passage.

[0065] In the example of FIG. 12, a first mucosal tissue region 177a and a first serosal tissue region 178a are situated in the vicinity of the opening 175, while a second mucosal tissue region 177b and a second serosal tissue region 178b are situated at another location in the vicinity of the opening 175. The first and second serosal tissue regions 178a and 178b preferably are spaced apart around the opening 175, and preferably are spaced on opposite sides of the opening 175, as depicted in FIG. 12.

[0066] In order to facilitate closure of the opening 175, at least one tacking device 20 is disposed through the tissue 174 at one or more locations in the vicinity of the opening 175. Preferably, the one or more tacking devices 20 are disposed in a manner that maintains pressure between the first serosal tissue region 178a and the second serosal tissue region 178b, as explained in detail below. By achieving serosa-to-serosa contact of the tissue 174 at one or more locations at least partially surrounding the opening 175, enhanced sealing of the opening 175 and healing of the tissue 174 may be achieved.

[0067] Referring to FIG. 13, at least one tacking device 20 is delivered using an insertion tool, such as the insertion tool 50, preferably in the manner described above. In particular, one or more tacking devices may be loaded into the hollow lumen 54 in a delivery configuration, as described above and shown in FIG. 3. In the delivery configuration, the proximal and distal deployable members 35-37 and 45-47 of each tacking device 20 may comprise a substantially longitudinally-oriented profile, i.e., oriented along a longitudinal axis of the insertion tool 50. Further, as noted above, the insertion tool 50 may be used in conjunction with another device, such as an endoscope, and may be delivered through a working lumen of the endoscope or similar device.

[0068] The insertion tool 50 is advanced, using any of the suitable imaging techniques noted above, towards the first mucosal tissue region 177a in the vicinity of the opening 175. Once at a desired location, the insertion tool 50 may be advanced distally through the first mucosal tissue region 177a and then through the first serosal tissue region 178a, as shown in FIG. 13. Referring to FIG. 14, in a next step the distal end of the insertion tool 50 may be manipulated in a manner that causes the sharpened distal tip 52 of the insertion tool 50 to pierce through the second serosal tissue region 178b, then subsequently through the second mucosal tissue region 177b, on the other side of the opening 175. At this time, the first serosal tissue region

178a and the second serosal tissue region 178b are pierced by the insertion tool 50 and both may be disposed in close proximity or abutting one another along the insertion tool 50, as depicted in FIG. 14.

[0069] In one exemplary technique, the sharpened distal tip 52 of the insertion tool 50 may be manipulated to “retroflex” about 180 degrees so that it may pierce back through the second serosal tissue region 178b and subsequently through the second mucosal tissue region 177b. Alternatively, or in conjunction with flexure of the insertion tool 50, the endoscope or other device delivering the insertion tool 50 may be angled in a manner that facilitates guidance and piercing of the insertion tool 50 through the second serosal tissue region 178b.

Still further, portions of the tissue 174 on any side of the opening 175 may be manipulated, as needed, to facilitate guidance and piercing of the insertion tool 50 through the second serosal tissue region 178b, as depicted in FIG. 14. Further, the endoscope or other device delivering the insertion tool 50 may be advanced distally to help hold the first serosal tissue region 178a and the second serosal tissue region 178b in close proximity or abutting one another, or alternatively, a catheter, sheath, or other pushing member may be advanced to urge the tissue segments together.

[0070] Referring to FIGS. 15-16, with the insertion tool 50 disposed through the second mucosal tissue region 177b, and the two tissue segments held together, a first tacking device 20a may be deployed. Specifically, the stylet 60 of FIG. 3 may be held steady with respect to the insertion tool 50, while the insertion tool 50 is retracted in a proximal direction. Alternatively, the stylet 60 may be advanced distally relative to the insertion tool 50. This causes the distal deployable members 45-47 of the tacking device 20a to extend distal to the sharpened tip 52 of the insertion tool 50, as depicted in FIG. 15. When the distal deployable members 45-47 are no longer radially constrained by the insertion tool 50, they may assume their predetermined expanded configurations in which they may engage, penetrate and/or abut the tissue of the second mucosal tissue region 177b. As the insertion tool 50 further is retracted proximally with respect to the tacking device 20a, the proximal deployable members 35-37 may assume their predetermined expanded configuration when are no longer radially constrained. In the expanded configuration, the proximal deployable members 35-37 may engage, penetrate and/or abut the first mucosal tissue region 177a. As noted above, an endoscope or other device delivering the insertion tool, or a separate catheter, sheath, or other

pushing member, may be used to hold the tissue segments together during deployment of the tacking device 20.

[0071] After deployment of the tacking device 20, the first serosal tissue region 178a and the second serosal tissue region 178b are held in an abutting, sealing relationship with one another. In particular, the proximal and distal deployable members 35-37 and 45-47 may urge the tissue segments toward one another, such that the first and second serosal tissue regions 178a and 178b are sandwiched together, as shown in FIG. 16. By achieving a compressive, serosa-to-serosa sealing relationship of tissue regions surrounding the opening 175, it has been found that an enhanced sealing of the opening 175 may be achieved. If desired, additional tacking devices 20, which may have been pre-loaded sequentially into the insertion tool 50 proximal to the first tacking device 20a, may be delivered through other tissue regions in the vicinity of the opening 175, in the same manner described above for the first tacking device 20a, to further facilitate serosa-to-serosa sealing of the opening 175. The group of tacking devices 20 may be aligned and spaced apart along the opening, and may be deployed and positioned based on the size and shape of the opening. It should be noted that the one or more tacking device 20 may remain inside the body, or may fall out and pass naturally through the body after the tissue has successfully healed.

[0072] Further, in FIG. 16, it should be noted that the longitudinal distance L_1 between the end regions 39 and 49 of the tacking devices 20 (see FIG. 1) may be sized to be approximately equal to, or slightly less than, a combined thickness t_3 of the two abutting tissue segments. If the longitudinal distance L_1 between the end regions 39 and 49 is less than the combined thickness t_3 , then the proximal and distal deployable members 35-37 and 45-47 may penetrate into the first and second mucosal tissue regions 177a and 177b, respectively, and apply an increased compressive force on the abutting tissue segments. It will also be recognized that the proximal and distal deployable members 35-37 and 45-47 may be partially or completely embedded within the tissue, e.g., as shown in FIGS. 7-8 above. In some embodiments, the overall length of the tacking device 20 may be less than the combined thickness t_3 of the two abutting tissue segments.

[0073] In further alternative embodiments, the apparatus and methods described herein may be used for facilitating closure of an opening in a layer of material, and are not restricted to methods for treatment of a human or animal body by surgery or therapy. For example, a relatively flexible layer of material having an opening therein may be maneuvered such that

first and second segments situated on substantially opposing sides of the opening are disposed in close proximity or abutting one another. Then, the tacking device 20 may be deployed to impose a compressive force to hold the first segment in a sealing relationship against the second segment to facilitate sealing of the opening, in accordance with the teachings hereinabove.

[0074] While various embodiments of the invention have been described, the invention is not to be restricted except in light of the attached claims and their equivalents. Moreover, the advantages described herein are not necessarily the only advantages of the invention and it is not necessarily expected that every embodiment of the invention will achieve all of the advantages described.

CLAIMS

We claim:

1. A method for facilitating closure of an opening in a layer of material, the method comprising:
 - 5 positioning a first tacking device in a lumen of a delivery tool;
 - advancing the delivery tool through a first segment of the material in a direction from a first surface of the material through a second surface of the material;
 - advancing the delivery tool through a second segment of the material in a direction from the second surface through the first surface, wherein the first and second segments at
10 least partially surround the opening in the layer of the material; and
 - translating the delivery tool with respect to the first tacking device to deploy the first tacking device from the lumen of the delivery tool,
15 wherein the tacking device, when deployed, imposes a compressive force to hold the first segment in a sealing relationship against the second segment to facilitate sealing of the opening.
2. The method of claim 1 wherein the first and second segments are situated on substantially opposing sides of the opening in the layer of material.
3. The method of claim 1 wherein the first tacking device comprises at least one proximal deployable member having contracted and expanded states, and further comprises at
20 least one distal deployable member having contracted and expanded states.
4. The method of claim 3 wherein the first tacking device is disposed within the lumen of the delivery tool with the proximal and distal deployable members in the contracted states, and wherein the proximal and distal deployable members self-expand to the expanded states upon deployment from the delivery tool.
- 25 5. The method of claim 4 wherein the proximal and distal deployable members of the first tacking device self-expand to hook-shaped configurations in the expanded states.

6. The method of claim 4 wherein a longitudinal distance between end regions of the proximal and distal deployable members is less than a combined thickness of the first and second segments to cause the proximal and distal deployable members to apply a compressive force between the first and second segments.
- 5 7. A method for facilitating closure of a bodily opening, the method comprising:
manipulating at least one of a first tissue segment and a second tissue segment,
wherein the first and second tissue segments at least partially surround an opening in tissue,
such that a first serosal tissue region of the first tissue segment is disposed adjacent to a
second serosal tissue region of the second tissue segment; and
10 imposing a compressive force to hold the first serosal tissue region in a sealing
relationship against the second serosal tissue region to facilitate sealing of the opening,
wherein at least a first tacking device having proximal and distal deployable members
is used to impose the compressive force to hold the first and second serosal tissue regions
together.
- 15 8. The method of claim 7 further comprising:
positioning the first tacking device in a lumen of an insertion tool;
advancing the insertion tool through the first tissue segment in a direction from a first
mucosal tissue region through the first serosal tissue region;
advancing the insertion tool through the second tissue segment in a direction from the
20 second serosal tissue region through a second mucosal tissue region; and
translating the insertion tool with respect to the first tacking device to deploy the first
tacking device from the lumen of the insertion tool.
9. The method of claim 8 wherein the insertion tool is manipulated in a direction that
permits piercing from the first serosal tissue region through the second serosal tissue region.
- 25 10. The method of claim 7 wherein the first tacking device comprises at least one
proximal deployable member having contracted and expanded states, and further comprises at
least one distal deployable member having contracted and expanded states, wherein the first
tacking device is disposed within the lumen of the insertion tool with the proximal and distal

deployable members in the contracted states, and wherein the proximal and distal deployable members self-expand to hook-shaped configurations in the expanded states upon deployment from the insertion tool.

11. The method of claim 10 wherein the proximal deployable members engage the first
5 mucosal tissue region in the expanded state, and the distal deployable members engage the second mucosal tissue region in the expanded state.

12. The method of claim 11 wherein a longitudinal distance between end regions of the proximal and distal deployable members is less than a combined thickness of the first and second tissue segments to cause the proximal and distal deployable members to apply a
10 compressive force between the first and second tissue segments.

13. A method for facilitating closure of a bodily opening, the method comprising:
positioning a first tacking device in a lumen of an insertion tool, wherein the first tacking device comprises at least one proximal deployable member having contracted and expanded states, and further comprises at least one distal deployable member having
15 contracted and expanded states, wherein the first tacking device is disposed within the lumen of the insertion tool with the proximal and distal deployable members in the contracted states;
manipulating at least one of a first tissue segment and a second tissue segment, wherein the first and second tissue segments at least partially surround an opening in tissue, such that a first serosal tissue region of the first tissue segment is disposed adjacent to a
20 second serosal tissue region of the second tissue segment; and
deploying the first tacking device from the lumen of the insertion tool to cause the proximal and distal deployable members to self-expand to the expanded states,
wherein the proximal and distal deployable members, in the expanded states, impose a compressive force to hold the first serosal tissue region in a sealing relationship against the
25 second serosal tissue region to facilitate sealing of the opening.

14. The method of claim 13 wherein the proximal and distal deployable members of the first tacking device self-expand to hook-shaped configurations in the expanded states.

15. The method of claim 13 further comprising:
advancing the insertion tool through a first tissue segment in a direction from a first mucosal tissue region through the first serosal tissue region;
advancing the insertion tool through a second tissue segment in a direction from the
5 second serosal tissue region through a second mucosal tissue region; and
translating the insertion tool with respect to the first tacking device to deploy the first tacking device from the lumen of the insertion tool.
16. The method of claim 15 wherein the insertion tool is manipulated in a direction that permits piercing from the first serosal tissue region through the second serosal tissue region.
- 10 17. The method of claim 13 wherein the proximal deployable members engage the first mucosal tissue region in the expanded state, and distal deployable members engage the second mucosal tissue region in the expanded state.
18. The method of claim 17 wherein a longitudinal distance between end regions of the proximal and distal deployable members is less than a combined thickness of the first and
15 second tissue segments to cause the proximal and distal deployable members to apply a compressive force between the first and second tissue segments.

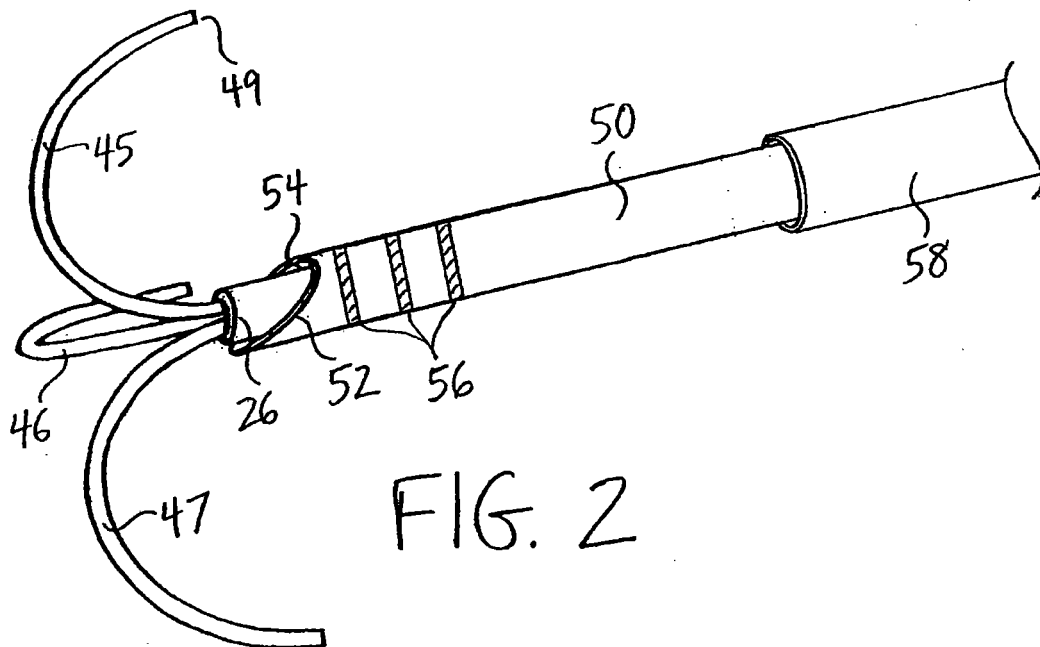
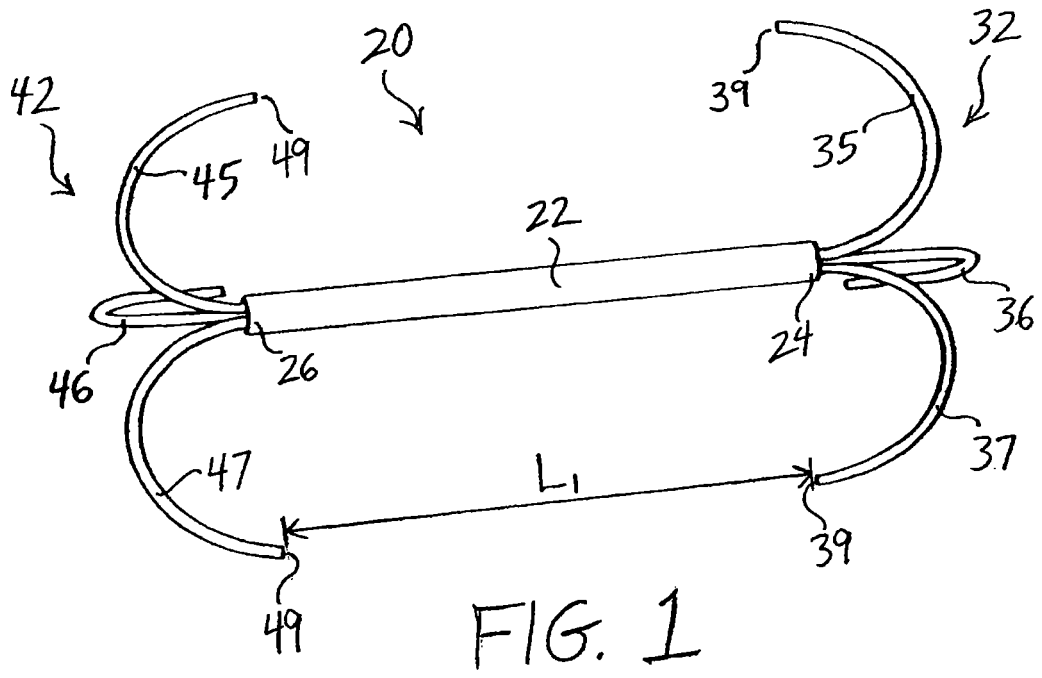

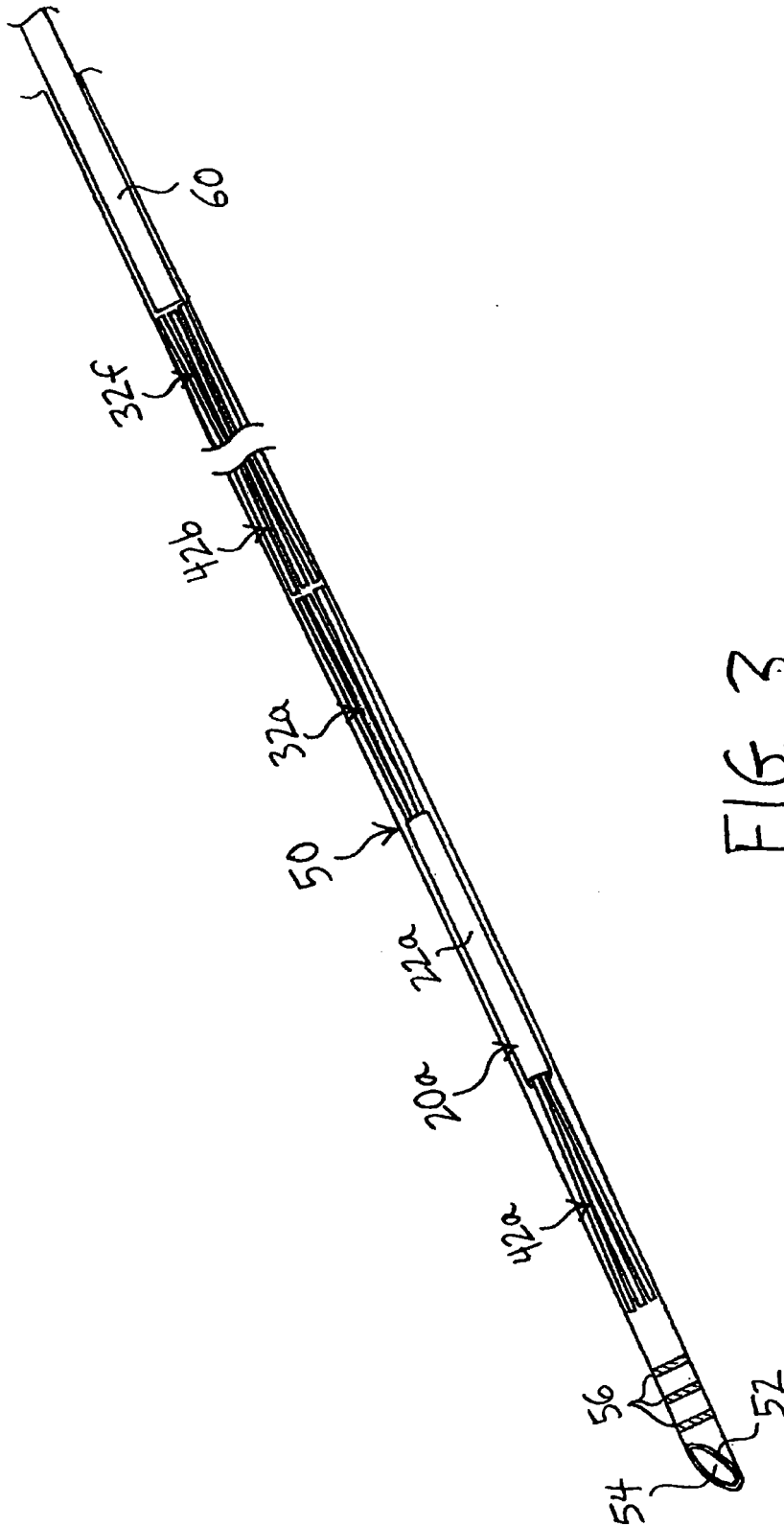

FIG. 3

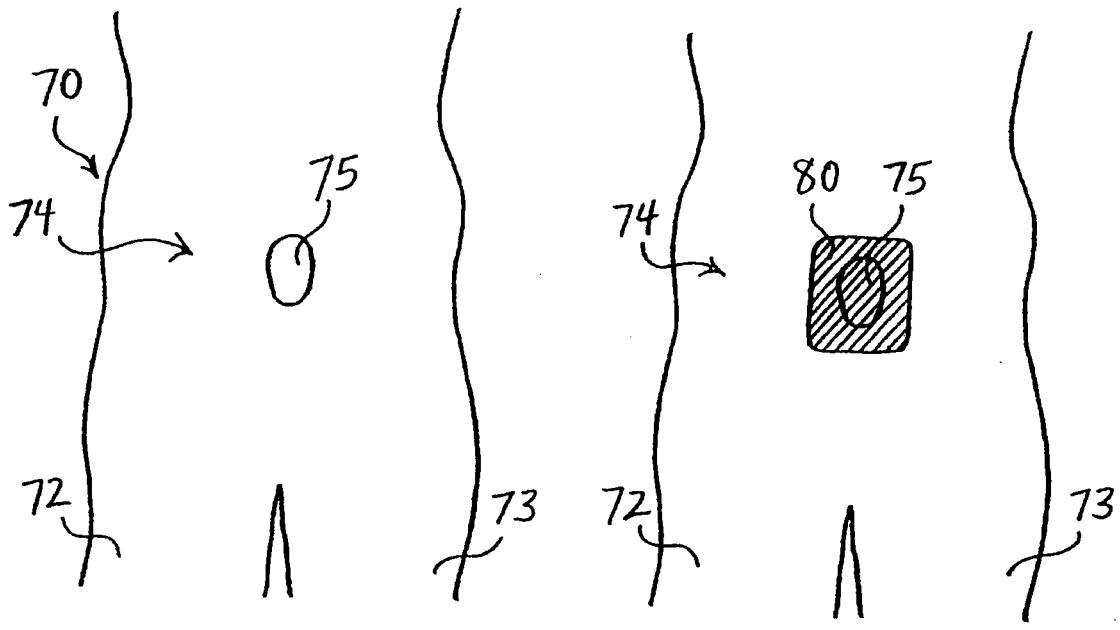

FIG. 4

FIG. 5

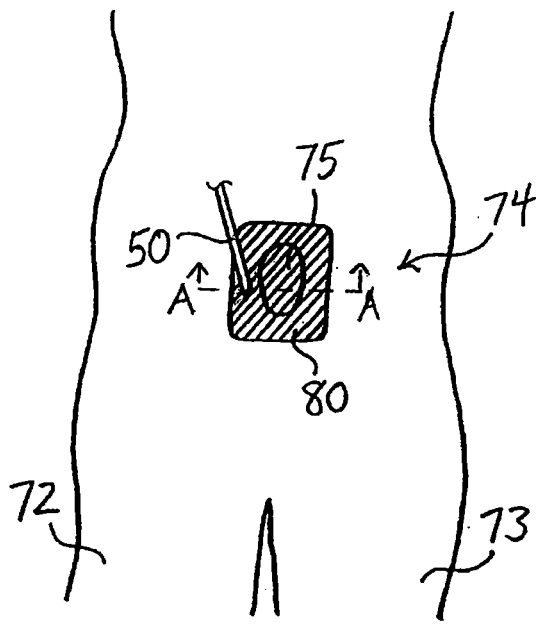

FIG. 6

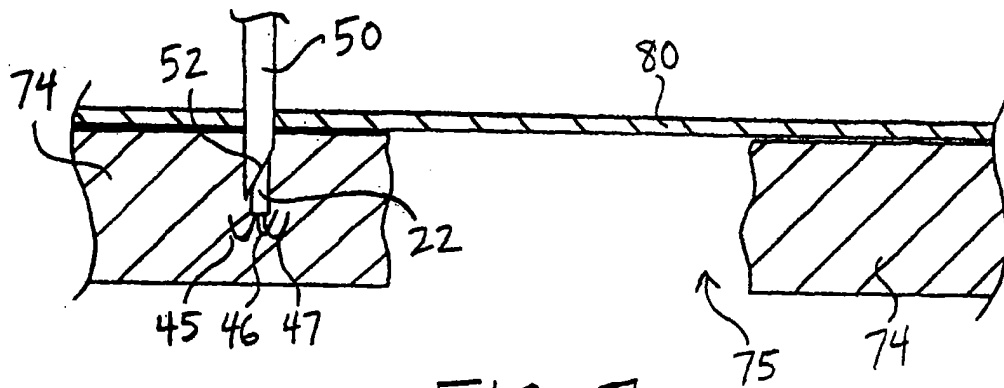

FIG. 7

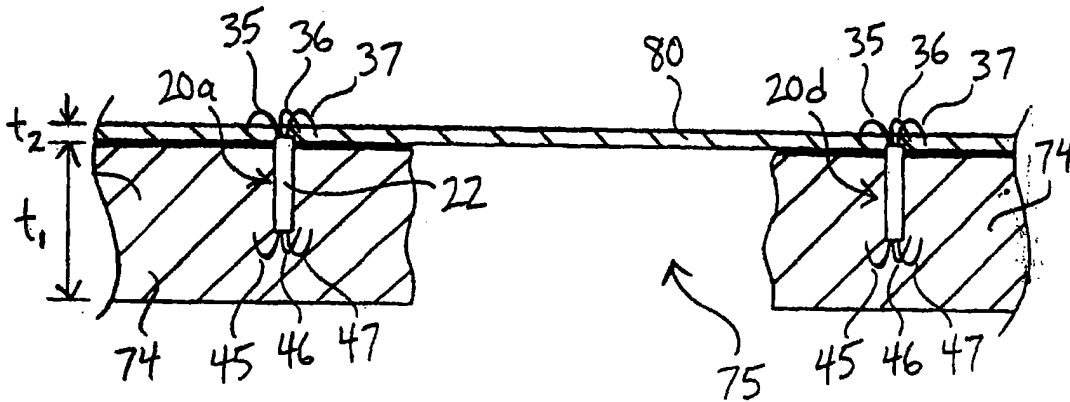

FIG. 8

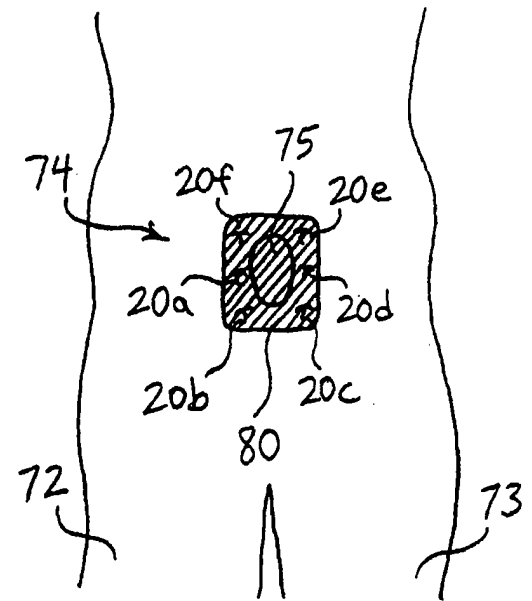

FIG. 9

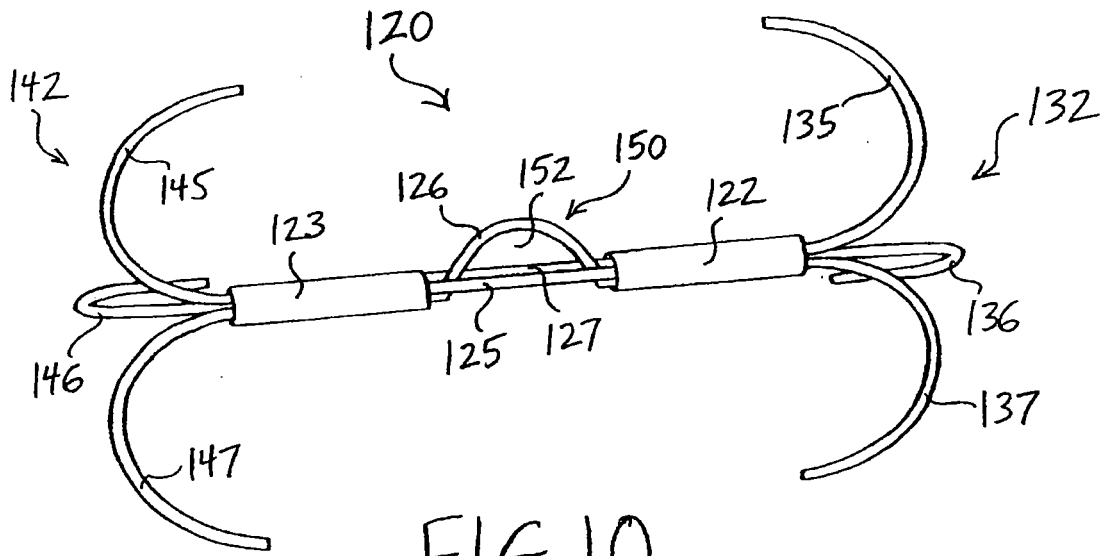

FIG. 10

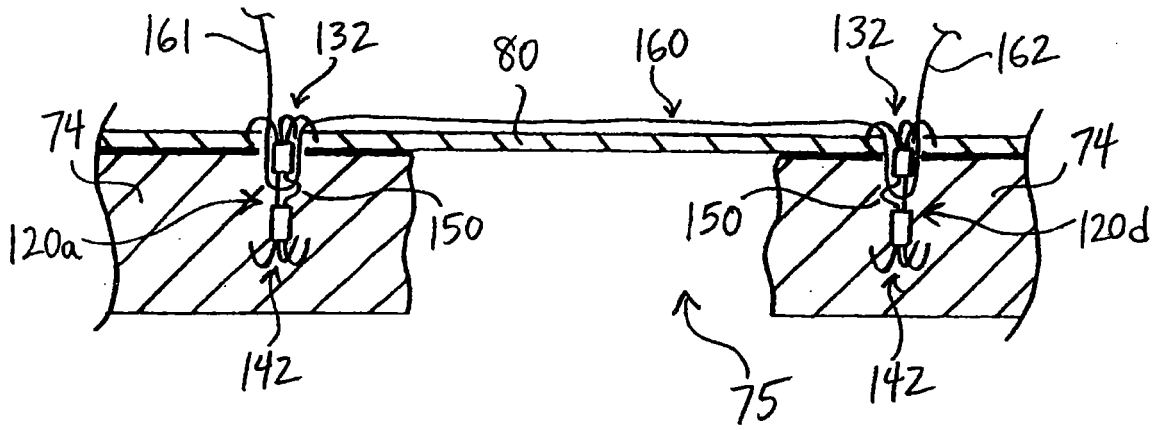

FIG. 11

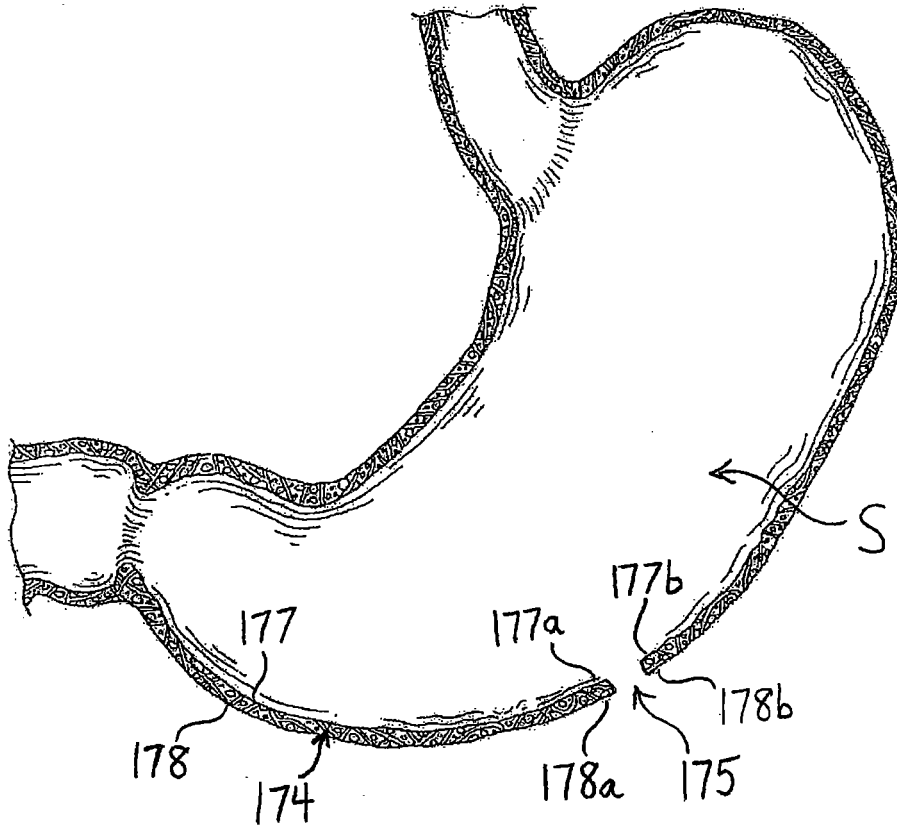

FIG. 12

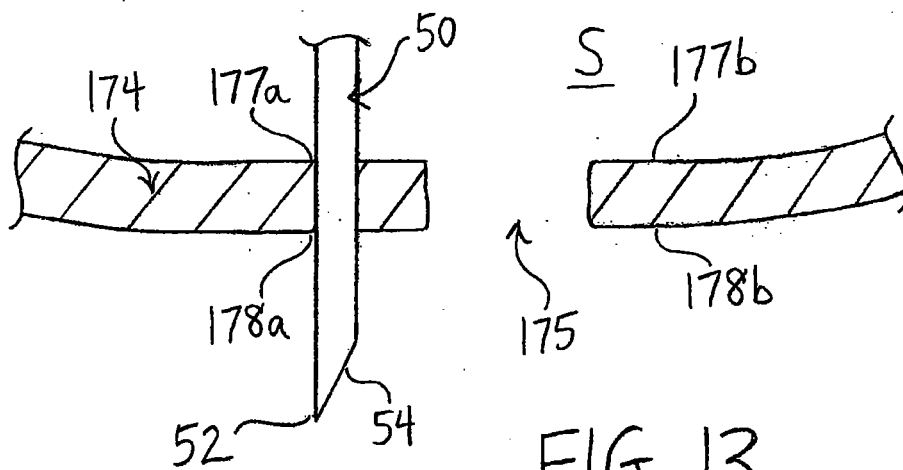

FIG. 13

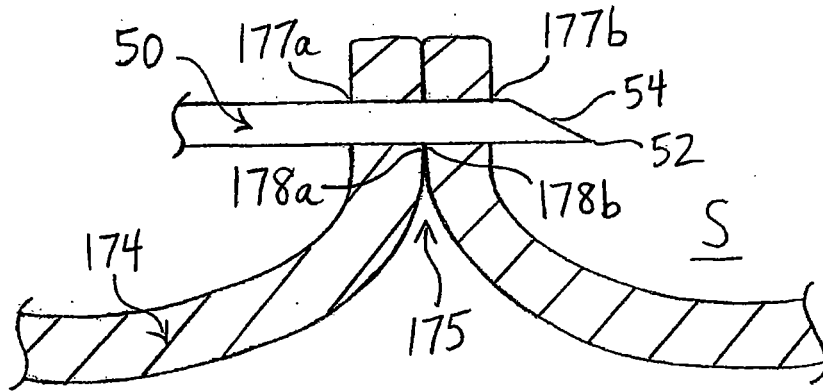

FIG. 14

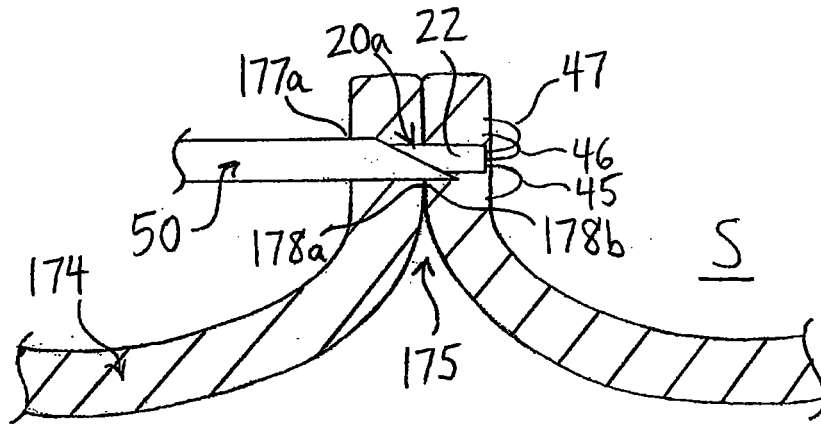

FIG. 15

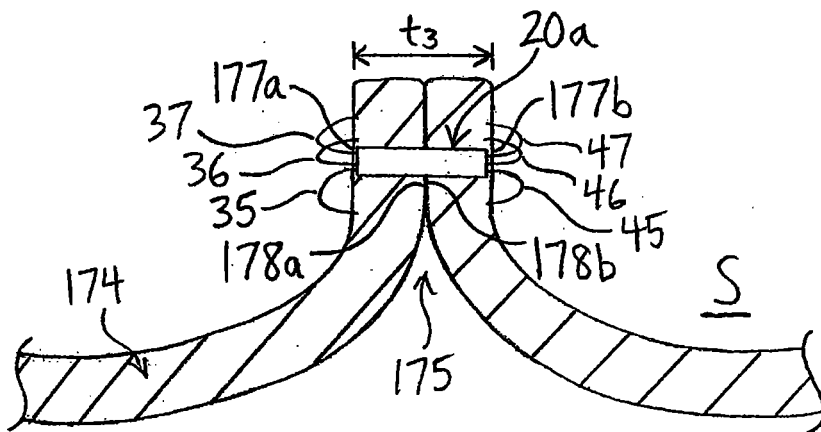

FIG. 16

INTERNATIONAL SEARCH REPORT

International application No
PCT/US2009/056512

A. CLASSIFICATION OF SUBJECT MATTER		
INV. A61B17/04	A61B17/064	
ADD. A61B17/08	A61B17/10	A61B17/128 A61B17/00
According to International Patent Classification (IPC) or to both national classification and IPC		
B. FIELDS SEARCHED		
Minimum documentation searched (classification system followed by classification symbols) A61B		
Documentation searched other than minimum documentation to the extent that such documents are included in the fields searched		
Electronic data base consulted during the international search (name of data base and, where practical, search terms used) EPO-Internal, WPI Data		
C. DOCUMENTS CONSIDERED TO BE RELEVANT		
Category*	Citation of document, with indication, where appropriate, of the relevant passages	Relevant to claim No.
X	US 4 006 747 A (KRONENTHAL RICHARD L ET AL) 8 February 1977 (1977-02-08) column 1, line 39 - line 64; figures 1-9 column 2, line 19 - column 5, line 4 -----	1-6
X	US 4 621 639 A (TRANSUE JAMES A [US] ET AL) 11 November 1986 (1986-11-11) column 1, line 61 - column 7, line 14; figures 1,2 -----	1-6
A	US 3 209 422 A (ARTHUR DRITZ) 5 October 1965 (1965-10-05) column 1, line 10 - line 24; figures 1-30 column 2, line 28 - column 6, line 75 -----	1-6
A	US 3 399 432 A (MERSER FRANCIS G) 3 September 1968 (1968-09-03) column 2, line 13 - line 44; figures 1-8 -----	1-6
-/--		
<input checked="" type="checkbox"/> Further documents are listed in the continuation of Box C.	<input checked="" type="checkbox"/> See patent family annex.	
* Special categories of cited documents :		
"A" document defining the general state of the art which is not considered to be of particular relevance	"T" later document published after the international filing date or priority date and not in conflict with the application but cited to understand the principle or theory underlying the invention	
"E" earlier document but published on or after the international filing date	"X" document of particular relevance; the claimed invention cannot be considered novel or cannot be considered to involve an inventive step when the document is taken alone	
"L" document which may throw doubts on priority claim(s) or which is cited to establish the publication date of another citation or other special reason (as specified)	"Y" document of particular relevance; the claimed invention cannot be considered to involve an inventive step when the document is combined with one or more other such documents, such combination being obvious to a person skilled in the art.	
"O" document referring to an oral disclosure, use, exhibition or other means	"&" document member of the same patent family	
"P" document published prior to the international filing date but later than the priority date claimed		
Date of the actual completion of the international search	Date of mailing of the international search report	
3 February 2010	10/02/2010	
Name and mailing address of the ISA/ European Patent Office, P.B. 5818 Patentlaan 2 NL - 2280 HV Rijswijk Tel. (+31-70) 340-2040, Fax: (+31-70) 340-3016	Authorized officer Neef, Tatjana	

INTERNATIONAL SEARCH REPORT

International application No

PCT/US2009/056512

C(Continuation). DOCUMENTS CONSIDERED TO BE RELEVANT		
Category*	Citation of document, with indication, where appropriate, of the relevant passages	Relevant to claim No.
A	US 6 156 044 A (KAMMERER GENE W [US] ET AL) 5 December 2000 (2000-12-05) column 1, line 11 - column 3, line 35; figures 1-29 column 5, line 21 - column 9, line 67 -----	1-6
A	US 6 241 747 B1 (RUFF GREGORY L [US]) 5 June 2001 (2001-06-05) column 1, line 62 - column 2, line 51; figures 1-11 column 6, line 24 - column 7, line 4 -----	1-6
A	US 2004/044364 A1 (DEVRIES ROBERT [US] ET AL) 4 March 2004 (2004-03-04) paragraph [0012] - paragraph [0020]; figures 1-16 paragraph [0044] - paragraph [0054] paragraph [0099] - paragraph [0108] -----	1-6
A	EP 1 317 904 A1 (ETHICON ENDO SURGERY [US]) 11 June 2003 (2003-06-11) paragraph [0015]; figures 1-37 paragraph [0019] - paragraph [0044] paragraph [0064] - paragraph [0077] -----	1-6

INTERNATIONAL SEARCH REPORT

International application No.
PCT/US2009/056512

Box No. II Observations where certain claims were found unsearchable (Continuation of item 2 of first sheet)

This international search report has not been established in respect of certain claims under Article 17(2)(a) for the following reasons:

1. Claims Nos.: 7-18
because they relate to subject matter not required to be searched by this Authority, namely:
Rule 39.1(iv) PCT - Method for treatment of the human or animal body by surgery.
2. Claims Nos.:
because they relate to parts of the international application that do not comply with the prescribed requirements to such an extent that no meaningful international search can be carried out, specifically:
3. Claims Nos.:
because they are dependent claims and are not drafted in accordance with the second and third sentences of Rule 6.4(a).

Box No. III Observations where unity of invention is lacking (Continuation of item 3 of first sheet)

This International Searching Authority found multiple inventions in this international application, as follows:

1. As all required additional search fees were timely paid by the applicant, this international search report covers all searchable claims.
2. As all searchable claims could be searched without effort justifying an additional fees, this Authority did not invite payment of additional fees.
3. As only some of the required additional search fees were timely paid by the applicant, this international search report covers only those claims for which fees were paid, specifically claims Nos.:
4. No required additional search fees were timely paid by the applicant. Consequently, this international search report is restricted to the invention first mentioned in the claims; it is covered by claims Nos.:

Remark on Protest

- The additional search fees were accompanied by the applicant's protest and, where applicable, the payment of a protest fee.
- The additional search fees were accompanied by the applicant's protest but the applicable protest fee was not paid within the time limit specified in the invitation.
- No protest accompanied the payment of additional search fees.

INTERNATIONAL SEARCH REPORT

Information on patent family members

International application No PCT/US2009/056512

Patent document cited in search report	Publication date	Publication date	Patent family member(s)	Publication date
US 4006747	A	08-02-1977	CA 1069009 A1	31-12-1979
			DE 2617211 A1	04-11-1976
			FR 2308349 A1	19-11-1976
			GB 1549666 A	08-08-1979
			IT 1058181 B	10-04-1982
			JP 51130091 A	12-11-1976
US 4621639	A	11-11-1986	NONE	
US 3209422	A	05-10-1965	NONE	
US 3399432	A	03-09-1968	BE 714123 A	24-10-1968
			FR 93590 E	18-04-1969
			GB 1156290 A	25-06-1969
			JP 50016691 B	14-06-1975
			NL 6717369 A	25-10-1968
US 6156044	A	05-12-2000	AU 735951 B2	19-07-2001
			AU 4829697 A	18-06-1998
			BR 9705514 A	07-12-1999
			CA 2224366 A1	11-06-1998
			CN 1194817 A	07-10-1998
			DE 69727772 D1	01-04-2004
			DE 69727772 T2	09-12-2004
			EP 0847727 A1	17-06-1998
			JP 10179598 A	07-07-1998
			US 6152935 A	28-11-2000
US 6241747	B1	05-06-2001	US 2004093028 A1	13-05-2004
			US 2007208355 A1	06-09-2007
			US 2008221617 A1	11-09-2008
US 2004044364	A1	04-03-2004	AU 2003263892 A1	19-03-2004
			CA 2463870 A1	11-03-2004
			EP 1530442 A2	18-05-2005
			JP 2006500090 T	05-01-2006
			WO 2004019787 A2	11-03-2004
			US 2009216265 A1	27-08-2009
EP 1317904	A1	11-06-2003	AU 2002315918 B2	19-10-2006
			CA 2413904 A1	10-06-2003
			CN 1449724 A	22-10-2003
			DE 60214319 T2	29-03-2007
			ES 2271199 T3	16-04-2007
			JP 2003210470 A	29-07-2003
			MX PA02012226 A	29-10-2004