

Oct. 6, 1970

B. F. KALINA

3,532,251

HAIR CURLER DISPENSING DEVICE

Filed Dec. 17, 1968

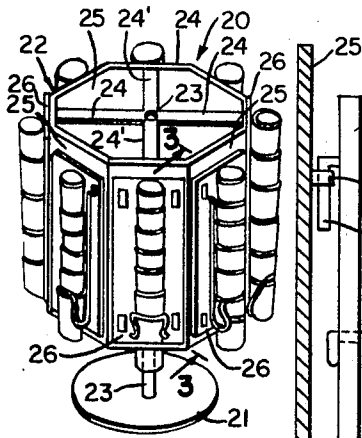

FIG. 1.

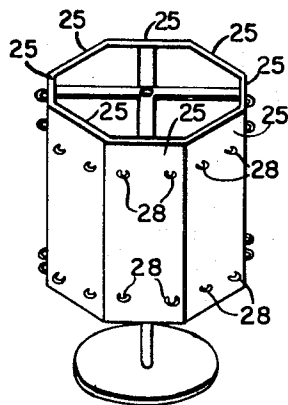

FIG. 2.

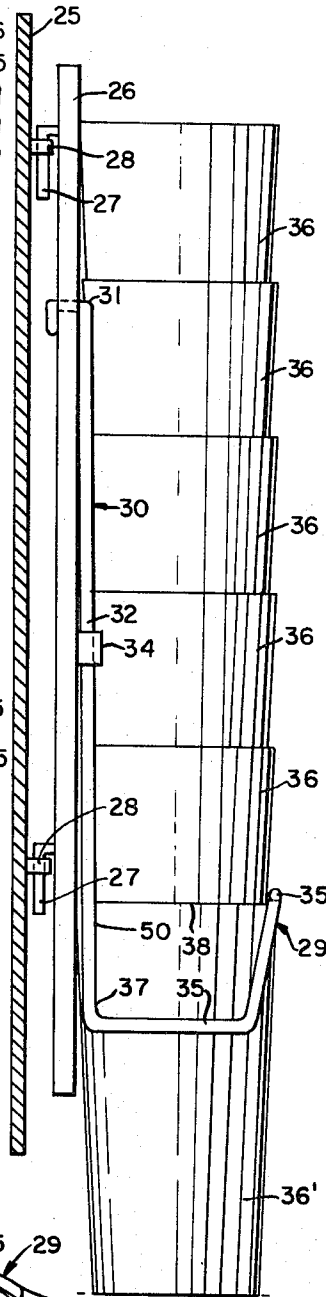

FIG. 3.

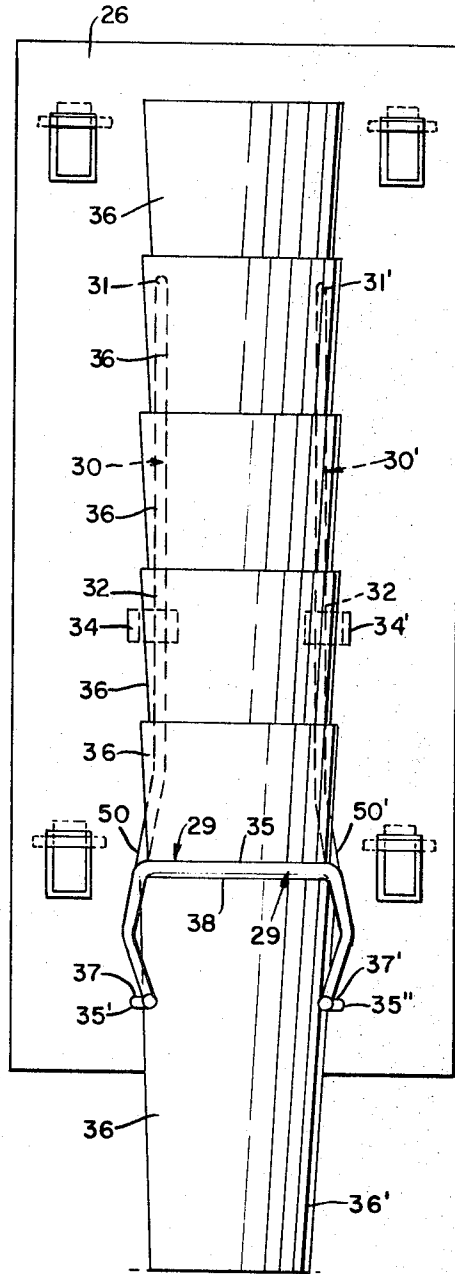

FIG. 4.

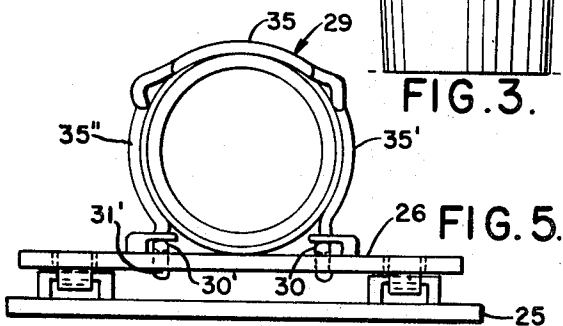

FIG. 5.

INVENTOR

Ben F. Kalina

BY *Robert E. Klave*

ATTORNEY

1

2

3,532,251

HAIR CURLER DISPENSING DEVICE

Ben F. Kalina, Bowman, N. Dak. 58623

Filed Dec. 17, 1968, Ser. No. 784,388

Int. Cl. A47f 1/08

U.S. Cl. 221-307

2 Claims

ABSTRACT OF THE DISCLOSURE

The invention comprises a hair curler device having a back wall and a resilient rod. The remote ends of the legs of the rod are mounted to the back wall and extend downward with the apex of the rod bent outward and upward for receiving a hair curler cone. The leg portions of the rod are adapted to flex apart to dispense a hair curler cone.

This invention relates to holding devices, more particularly, the invention relates to hair curler holding devices.

It is an object of the invention to provide a novel stand for holding hair curlers which enables the curlers to be individually dispensed from the stand.

It is a further object of the invention to provide a novel device for holding and dispensing hair curlers.

It is another object of the invention to provide a novel plate for stacking curlers thereon and for dispensing the curlers and which is attached to a rotatable stand.

Further objects and advantages of the invention will become apparent as the description proceeds and when taken in conjunction with the accompanying drawing wherein:

FIG. 1 is a perspective view of the novel curler dispensing invention.

FIG. 2 is a perspective view of the curler dispensing invention with the dispensing plate detached.

FIG. 3 is a cross-sectional view taken along line 3-3 of FIG. 1 illustrating one of the curler dispensing plates with the curlers attached in position for dispensing.

FIG. 4 is a front elevational view of one of the curler dispensing plates with the curlers attached in position for dispensing and with the dispensing plate attached to one of the side plates of the stand and a fragmentary showing of the side plate.

FIG. 5 is a top view of the curler dispensing plate shown attached to one of the side plates of the rotary stand, and with a fragmentary showing of the one side plate.

Briefly stated, the invention comprises a hair curler device having a dispenser stand, said stand having a plurality of side plates placed in edge to edge relation about a circle and fixed together, said side plates being rotatably mounted to an upright shaft, a plurality of dispensing plates detachably mounted to said side plates, each of said dispensing plates having a U-shaped metal rod formed of spring steel, said U-shaped rod having a lateral bend at its apex with the remote ends of said legs fixed to said dispensing plate and with the lower portions of the legs being free of a said dispensing plate, said laterally bent apex of said U-rod being adapted to receive and support cone-like hair curlers in stacked relation, said arm portions of said rod adjacent said apex being adapted to be spread apart by the wedging action of the lower most cone when the lower most cone is pulled downward thereby freeing the lower most cone, said arm portions adjacent the apex adapted to spring back towards their original position once the lower most cone has cleared the arm portions and engage the sides of the next cone in the stack above the lower most cone and hold it in the U-rod.

Referring more particularly to the drawing, in FIG. 1, the hair curler dispensing invention 20 is illustrated as having a circular base plate 21 to support a rotatable framework 22. The base plate 21 has an upright shaft 23. The rotatable frame work 22 has an upper and lower pair of cross bars 24 and 24' with the centers of the cross bars rotatably mounted to shaft 23. Eight rectangular mounting plates 25 are fixed in edgewise relation to one another about a circle and the cross bars 24 and 24' are fixed to the inside of the plate 25 to provide an inner structural support for the mounting plates 25 whereby the mounting plates may with their reinforcing and mounting cross bars be rotated about the shaft 23.

Eight rectangular dispensing plates 26 are detachably mounted to the mounting plates 25 as illustrated in FIG. 1. Each dispensing plate has four lugs 27 which project into four eyelets 28 in their respective mounting plates 25 in complementary relation as illustrated in FIGS. 3, 4, and 5. Each of the mounting plates 25 has its four eyelets 28 fixed to plate 25 to thereby support the dispensing plate 25.

Each dispensing plate 26 has a U-shaped spring steel resilient rod 29. The legs 30 and 30' of the U-shaped rod have their upper remote ends 31 and 31' bent laterally inward and fixed to the dispensing plate 26. The intermediate portions 32 and 32' of the rods are fitted into lugs 34 and 34' to prevent the legs of the rod 29 from spreading apart above the legs 34 and 34'. The apex 35 of the U-shaped rod 29 is bent laterally outwardly to form side portions 35' and 35'' which grip the sides of the lower most hair curler cone 36 as illustrated in FIGS. 2, 3, and 4. Also the legs 30 and 30' of the rod are normally straight from the upper remote ends 31 and 31' to locations 37 and 37' and are flush against the dispensing plate 26. The introducing of the cone 36 into the apex portion 35 of the rod urges the apex and lower portions 50 and 50' of the legs outward to their position illustrated in FIG. 3, with the spring reaction of the legs thereby holding the cones 36 firmly against the dispensing plate 26.

The hair curler cones 36 are hollow and identical in shape and will be stacked in telescoping relation as illustrated in FIGS. 3, 4 and 5 with the lowermost cone 36' held firmly in the dispensing plate by the side portions 35' and 35'' gripping the sides of the lowermost cone and also the rod holding the cones against the dispenser plate.

To dispense the cones 36, the operator will grasp the lowermost cone 36' and pull it downward which causes all of the legs 30 and 30' of the rod below the lugs 34 and 34' to flex apart by the wedging action of the outwardly tapered sides of the lowermost cones 36. The cones 36 will be slid downward until the upper edge 38 of the lowermost cone 36' clears the side portions 35' and 35'' of the rod whereupon, this frees the lower portions 50 and 50' of the legs 30 and 30' of the U-rod and allows them to spring back to their former position before the dispensing operation was started and grasp the next hair curler cone above the lowermost cone 36' and thereby holding the remainder of the cones 36 to the dispensing plate.

This operation can be repeated for each of the cones in the stack one after another until all of the cones have been dispensed.

Thus, it will be seen that a novel hair curler cone dispensing device has been provided for rapidly and individually dispensing hair curler cones.

It will be obvious that various changes and departures may be made to the invention without departing from the spirit and scope thereof and accordingly it is not intended that the invention be limited to that specifically described in the specification or as illustrated in the drawing but only as set forth in the appended claims wherein.

3

What is claimed is:

1. A hair curler dispensing device for dispensing hair curler cones comprising a rotatable stand, said stand having a plurality of mounting plates, a plurality of dispensing plates detachably mounted to said mounting plates, each of said dispensing plates having a U-shaped resilient rod attached thereto, said rod having a lateral bend at its apex for receiving a plurality of hair curler cones in stacked relation, said U-shaped rods each having leg portions adjacent the apex of the rod adapted to be flexed apart to allow the lowermost cone to pass there-through.

4

2. A hair curler dispensing device according to claim 1 wherein said dispensing plates each have projecting lugs and said mounting plates have eyelets for receiving said lugs for said detachable mounting of said dispensing plates to said mounting plates.

References Cited

UNITED STATES PATENTS

1,664,164	3/1928	Endter	-----	221—303	X
3,122,270	2/1964	Meng et al.	-----	221—309	X

STANLEY TOLLBERG, Primary Examiner