

(19) World Intellectual Property Organization
International Bureau



(43) International Publication Date
14 February 2008 (14.02.2008)

PCT

(10) International Publication Number
WO 2008/019086 A2

(51) International Patent Classification:
B65G 17/08 (2006.01)

(74) Agent: **OYER, Timothy, J.**; Wolf, Greenfield & Sacks, P.C., Federal Reserve Plaza, 600 Atlantic Avenue, Boston, MA 02210-2206 (US).

(21) International Application Number:
PCT/US2007/017380

(81) Designated States (unless otherwise indicated, for every kind of national protection available): AE, AG, AL, AM, AT, AU, AZ, BA, BB, BG, BH, BR, BW, BY, BZ, CA, CH, CN, CO, CR, CU, CZ, DE, DK, DM, DO, DZ, EC, EE, EG, ES, FI, GB, GD, GE, GH, GM, GT, HN, HR, HU, ID, IL, IN, IS, JP, KE, KG, KM, KN, KP, KR, KZ, LA, LC, LK, LR, LS, LT, LU, LY, MA, MD, ME, MG, MK, MN, MW, MX, MY, MZ, NA, NG, NI, NO, NZ, OM, PG, PH, PL, PT, RO, RS, RU, SC, SD, SE, SG, SK, SL, SM, SV, SY, TJ, TM, TN, TR, TT, TZ, UA, UG, US, UZ, VC, VN, ZA, ZM, ZW.

(22) International Filing Date: 2 August 2007 (02.08.2007)

(25) Filing Language: English

(26) Publication Language: English

(30) Priority Data:
60/835,828 4 August 2006 (04.08.2006) US

(84) Designated States (unless otherwise indicated, for every kind of regional protection available): ARIPO (BW, GH, GM, KE, LS, MW, MZ, NA, SD, SL, SZ, TZ, UG, ZM, ZW), Eurasian (AM, AZ, BY, KG, KZ, MD, RU, TJ, TM), European (AT, BE, BG, CH, CY, CZ, DE, DK, EE, ES, FI, FR, GB, GR, HU, IE, IS, IT, LT, LU, LV, MC, MT, NL, PL, PT, RO, SE, SI, SK, TR), OAPI (BF, BJ, CF, CG, CI, CM, GA, GN, GQ, GW, ML, MR, NE, SN, TD, TG).

(71) Applicant (for all designated States except US): **MASSACHUSETTS INSTITUTE OF TECHNOLOGY** [US/US]; 77 Massachusetts Avenue, Cambridge, MA 02139 (US).

(72) Inventors; and

(75) Inventors/Applicants (for US only): **SWAGER, Timothy, M.** [US/US]; 18 Copley Street, Newton, MA 02458 (US). **THOMAS, Samuel, W.** [US/US]; 15-308 South Point Drive, Boston, MA 02125 (US).

Published:
— without international search report and to be republished upon receipt of that report

(54) Title: DETECTION OF EXPLOSIVES, TOXINS AND OTHER COMPOSITIONS

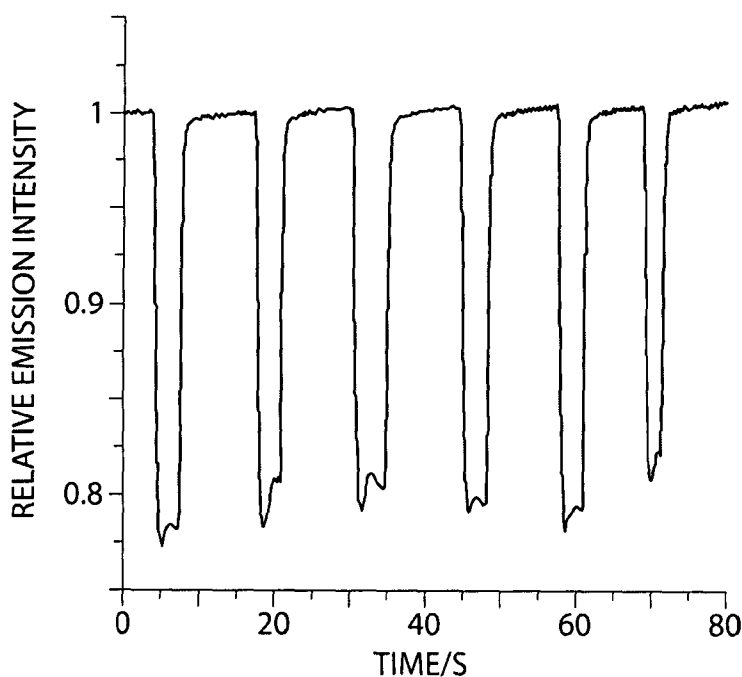

(57) Abstract: The present invention generally relates to methods for modulating the optical properties of a luminescent polymer via interaction with a species (e.g., an analyte). In some cases, the present invention provides methods for determination of an analyte by monitoring a change in an optical signal of a luminescent polymer upon exposure to an analyte. Methods of the present invention may be useful for the vapor phase detection of analytes such as explosives and toxins. The present invention also provides methods for increasing the luminescence intensity of a polymer, such as a polymer that has been photobleached, by exposing the luminescent polymer to a species such as a reducing agent.

WO 2008/019086 A2

DETECTION OF EXPLOSIVES, TOXINS, AND OTHER COMPOSITIONS

Field of the Invention

The present invention relates to methods for the determination of various
5 explosives and toxins. The present invention also relates to methods for increasing the
luminescence intensity of polymers.

Background of the Invention

Sensory devices based on amplified fluorescence quenching of solid-state
10 conjugated polymer films can be highly sensitive, due to the amplification that arises
from delocalized excitons sampling many potential binding sites within one excited state
lifetime. Previous work has demonstrated highly sensitive detection schemes using these
amplifying fluorescent polymers for a number of analytes in solution and vapor phase, as
described in U.S. Publication No. 2003/0178607. For example, sensors for the ultratrace
15 detection of high explosives such as 2,4,6-trinitrotoluene (TNT) have been shown to
display high sensitivity comparable to that of trained canines. In many cases, the
transduction mechanism is photoinduced charge transfer (PICT) from a polymer donor to
a substantially planar analyte that binds via a tight pi-complex to the conjugated
polymer. For example, TNT is a planar, nitroaromatic molecule that can readily form a
20 pi-complex with a conjugated polymer via pi-stacking interactions.

Although planar and/or aromatic compounds are often present in many
explosives, present day security is in need of systems capable of matching
comprehensive vapor phase detection of a broader range of high explosives and toxins.
For example, the taggant 2,3-dimethyl-2,3-dinitrobutane (DMNB) is a required additive
25 in all legally manufactured plastic explosives. DMNB has been previously detected
using ion mobility spectrometry, a reliable but less sensitive technique relative to
amplifying fluorescent polymers. DMNB has also been detected using other methods
such as electron capture mass spectrometry which involve bulky and often complex
machinery.

30 Hydrazine (NH_2NH_2), a heavily used industrial chemical, has been implicated as
a carcinogen and is readily absorbed through the skin. Its strong reducing power has led
to its use as an oxygen scavenger and corrosion inhibitor in various applications
involving water-heating systems, as well as a fuel in rocket propulsion systems. As a

result of its toxicity and reactivity, facile detection of hydrazine is also relevant to homeland security. Traditional analytical methods utilized for hydrazine detection include spectrophotometric detection, as well as assorted electrochemical schemes.

Accordingly improved methods are needed.

5

Summary of the Invention

The present invention provides methods for determination of 2,3-dimethyl-2,3-dinitrobutane (DMNB), comprising exposing a luminescent polymer to a sample suspected of containing DMNB, wherein DMNB, if present, interacts with the luminescent polymer to cause a change in the luminescence of the polymer and determining the change in the luminescence of the polymer, thereby determining DMNB.

The present invention also provides methods for determination of hydrazine or hydrazine derivatives, comprising exposing a luminescent polymer to a sample suspected of containing hydrazine or hydrazine derivatives, wherein hydrazine or the hydrazine derivative, if present, interacts with the luminescent polymer to cause an increase in the luminescence intensity of the polymer, determining the increase in luminescence intensity of the polymer, thereby determining hydrazine or the hydrazine derivative.

The present invention also provides methods for increasing the luminescence intensity of a polymer, comprising exposing a luminescent polymer to hydrazine or the hydrazine derivative, wherein, in the absence of hydrazine or the hydrazine derivative, the luminescent polymer comprises non-radiative pathways, and, in the presence of hydrazine or the hydrazine derivative, hydrazine or the hydrazine derivative interacts with the luminescent polymer to reduce the number of non-radiative pathways, thereby increasing the luminescence intensity of the polymer.

25

Brief Description of the Drawings

FIG. 1 shows luminescent polymers, according to some embodiments of the invention.

FIG. 2 shows a schematic representation of qualitative energy level diagrams of the valence bands and conduction bands of polymers, according to some embodiments of the invention.

FIG. 3 shows the fluorescence emission intensity response of a thin film of polymer P5 to repeated variable time exposures to equilibrium DMNB vapor.

FIG. 4 shows the fluorescence emission intensity response of a thin film of polymer P5 upon a ~20 s exposure to equilibrium vapor of either (a) DMNB or (b) benzophenone.

FIG. 5 shows the emission spectra of polymer P3 (a) before and (b) after exposure to a equilibrium vapor of hydrazine for 10 seconds.

FIG. 6 shows the time-dependent emission of a photobleached film of polymer P2 in a FIDO sensing platform exposed to 1 ppm (permissible exposure limit) hydrazine vapor for 60 seconds.

FIG. 7 UV/vis spectra of a film of polymer P3 (a) before exposure to I₂ vapor, (b) after exposure to I₂ vapor, and (c) after exposure of the I₂-doped film to saturated hydrazine vapor for 5 seconds.

FIG. 8 shows the emission response of polymer P2 (a) before exposure to I₂, (c) after exposure to I₂ for approximately 5 seconds, and (b) after exposure of the I₂-doped film to hydrazine vapor, and (d) the fluorescence trace of the I₂-doped film exposed to 1 ppm hydrazine.

FIG. 9 shows a plot of normalized emission intensity of a film of P3 as a function of time upon exposure to saturated iodine vapor (quench) followed by saturated hydrazine vapor (recovery).

FIG. 10 shows an illustrative embodiment of a synthetic scheme for synthesizing poly(phenylene ethynylene)s, according to one embodiment of the invention.

FIG. 11 shows several illustrative embodiments for the synthesis of electron-rich monomers containing amine groups.

Detailed Description

The present invention generally relates to methods for modulating the optical properties of a luminescent polymer via interaction with a species (e.g., an analyte).

In some cases, the present invention provides methods for determination of an analyte. The analytes may be determined by monitoring, for example, a change in an optical signal of a luminescent material (e.g., polymer) upon exposure to an analyte. In some cases, the present invention may be used for the vapor phase detection of analytes such as explosives and toxins. Methods of the present invention may be advantageous in that the high sensitivity of luminescence (e.g., fluorescence) spectroscopy can allow for

the reliable detection of small changes in luminescence intensity. The present invention also provides methods for increasing the luminescence intensity of a polymer, such as a polymer that has been photobleached, by exposing the luminescent polymer to a species such as a reducing agent.

5 Methods for the determination of analytes (e.g., non-planar analytes, non-aromatic analytes) may comprise exposure of a luminescent polymer to a sample suspected of containing the analyte, and, if present, the analyte interacts with the luminescent polymer to cause a change in the luminescence of the polymer. The change in the luminescence of the polymer may then determine the analyte. In some cases, the
10 change comprises a decrease in luminescence intensity. In some cases, the change comprises an increase in luminescence intensity. As used herein, the term "determining" generally refers to the analysis of a species or signal, for example, quantitatively or qualitatively, and/or the detection of the presence or absence of the species or signals. "Determining" may also refer to the analysis of an interaction between two or more
15 species or signals, for example, quantitatively or qualitatively, and/or by detecting the presence or absence of the interaction. The materials and methods described herein may be incorporated into devices such as sensors or any device or article capable of detecting an analyte. In some embodiments, the analyte (e.g., DMNB, hydrazine) may be determined when present in only trace quantities.

20 The present invention may be particularly advantageous in that analytes which do not readily form pi-stacking interactions with conjugated polymers may be determined. As used herein, "pi-stacking interactions" refer to cofacial interactions between pi-orbitals of conjugated species. Examples of such analytes include those which are, for example, non-planar, non-aromatic, and/or have relatively high reduction potentials (i.e.,
25 weak electron affinity). The taggant 2,3-dimethyl-2,3-dinitrobutane (DMNB) may be characterized by a non-planar, three-dimensional structure and a reduction potential of -1.7 V (versus standard calomel electrode, SCE), making it difficult for DMNB to engage in pi-stacking interactions with luminescent polymers having pi-conjugated moieties. Other explosives may include RDX (hexahydro-1,3,5-trinitro-1,3,5-triazine), PETN (2,2-bis[(nitrooxy)-methyl]-1,3-propanediol dinitrate (ester)), other nitro- or nitrate-
30 containing species, and the like. Methods of the invention may also be advantageous for various toxins including strong reducing agents, such as hydrazine and hydrazine derivatives.

The interaction between the luminescent polymer and the analyte may comprise, for example, energy transfer (e.g., photoinduced charge transfer, fluorescence resonance energy transfer), electrostatic interactions, binding interactions, redox reactions (e.g., reduction, oxidation), other chemical reactions, and the like. In some cases, the analyte may be an electron acceptor and the luminescent polymer may be an electron donor. In some cases, the analyte may be an electron donor and the luminescent polymer may be an electron acceptor. In some embodiments, the analyte may also act as a reducing agent to increase the luminescence intensity of a polymer.

In some embodiments, the interaction between the luminescent polymer and the analyte comprises photoinduced charge transfer, wherein an excited-state polymer transfers an electron to an analyte (e.g., DMNB). For example, the luminescent polymer may form an excited state upon exposure to electromagnetic radiation and produce a first emission signal. In the excited-state, the luminescent polymer may then interact with (e.g., transfer charge to) an analyte, resulting in a second emission which has decreased or "quenched" luminescence intensity (e.g., a "turn-off" detection mechanism). In an illustrative embodiment shown in FIG. 3, a film of polymer P5 exhibits a decrease in fluorescence emission intensity upon repeated variable time exposures to DMNB vapor.

Alternatively, the interaction between the luminescent polymer and the analyte may comprise a chemical reaction such as a reduction reaction which may increase the luminescence intensity of the polymer. The luminescent polymer may exist in a "quenched" state and have substantially no emission signal upon exposure to electromagnetic radiation, wherein, upon interaction with an analyte, the analyte may interact with (e.g., reduce) at least a portion of the luminescent polymer and/or a quenching molecule associated with the luminescent polymer such that an emission signal is generated that has a greater luminescence intensity than the emission signal in the absence of analyte upon exposure to the same conditions of electromagnetic radiation (e.g., a "turn-on" detection mechanism). FIG. 9 shows an illustrative embodiment, wherein an I₂-doped (i.e., fluorescence quenched) film of polymer P3 shows an increase in fluorescence emission upon exposure to hydrazine vapor over multiple I₂/hydrazine exposure cycles.

In some cases, methods of the invention comprise determining a change in the wavelength of an emission signal. The wavelength of an emission signal refers to the wavelength at which the peak maximum of the emission signal occurs in an emission

spectrum. The emission signal may be a particular peak having the largest intensity in an emission spectrum (e.g. a fluorescence spectrum), or, alternatively, the emission signal may be a peak in an emission spectrum that has at least a defined maximum, but has a smaller intensity relative to other peaks in the emission spectrum.

5 In some embodiments, the change in luminescence intensity may occur for an emission signal with substantially no shift in the wavelength of the luminescence (e.g., emission), wherein the intensity of the emission signal changes but the wavelength remains essentially unchanged. In other embodiments, the change in luminescence intensity may occur for an emission signal in combination with a shift in the wavelength
10 of the luminescence (e.g., emission). For example, an emission signal may simultaneously undergo a shift in wavelength in addition to an increase or decrease in luminescence intensity. In another embodiment, the change may comprise two emission signals occurring at two different wavelengths, wherein each of the two emission signals undergoes a change in luminescence intensity. In some cases, the two emission signals
15 may undergo changes in luminescence intensity independent of one another. In some cases, the two emission signals may undergo changes in luminescence intensity, wherein the two emission signals are associated with one another, for example, via an energy transfer mechanism, as described more fully below.

In some embodiments, methods of the present invention may further comprise
20 determining a change in the wavelength of the luminescence upon exposure of a luminescent polymer to an analyte. That is, in some cases, determination of an analyte may comprise observing a change in luminescence intensity in combination with a change in the luminescence wavelength. For example, the relative luminescence intensities of a first emission signal and a second emission signal associated with the first
25 emission signal may be modulated using the quenching and unquenching methods described herein. In some cases, the first emission signal and the second emission signal may be associated with (e.g., interact with) one another via an energy transfer mechanism, such as fluorescence resonance energy transfer, for example. The term
30 "fluorescence resonance energy transfer" or "FRET" is known in the art and refers to the transfer of excitation energy from an excited state species (i.e., FRET donor) to an acceptor species (i.e., FRET acceptor), wherein an emission is observed from the acceptor species. In some cases, the FRET donor may be a luminescent polymer,

portion(s) thereof, or other species, such as an analyte. Similarly, the FRET acceptor may be a luminescent polymer, portion(s) thereof, or other species, such as an analyte.

In one embodiment, a first portion of a luminescent polymer may act as FRET donor and a second portion within the same luminescent polymer may act as a FRET acceptor, wherein the first portion and the second portion each have different emission wavelengths. The luminescent polymer may be associated with a quenching molecule and exist in a "quenched" state, wherein, upon exposure of the first portion to electromagnetic radiation, the quenching molecule absorbs the excitation energy and substantially no emission is observed. Upon exposure to an analyte, the analyte may interact with the luminescent polymer and/or quenching molecule to "un-quench" the luminescent polymer. As a result, exposure of the first portion to electromagnetic radiation produces an excited-state, wherein the first portion of the luminescent polymer may transfer excitation energy to the second portion of the luminescent polymer, and emission signal from the second portion is observed.

The properties of luminescent polymers of the invention may be tailored to suit a particular application, such as determination of a particular analyte. In some embodiments, the luminescent polymer may be designed interact with an analyte having high reduction potential (e.g., a high energy LUMO). For example, the band gap of a luminescent polymer may be designed to energetically favor interaction (e.g., photoinduced charge transfer) with an analyte. FIG. 2A shows the "band gap" of a pi-conjugated polymer which, as used herein, refers to the energy difference between the valence band and the conduction band. In the excited-state, electrons in the conduction band may be transferred to a species having a LUMO, which is lower in energy relative to the conduction band. As shown in FIG. 2A, polymer A has a conduction band which is lower in energy than the LUMO of an analyte, making energy transfer from the excited-state polymer to the analyte energetically unfavorable. In contrast, polymer B has a conduction band which is higher in energy than the LUMO of the analyte, making energy transfer from the excited-state polymer to the analyte energetically favorable.

The band gap of the luminescent polymer may be tailored such that the conduction band of the luminescent polymer is higher in energy than the LUMO of the analyte, producing a material having increased excited-state reduction potential that allows the polymer to transfer charge to the analyte in an energetically favorable manner.

In some cases, a wider band gap may enable more exergonic electron transfer from a higher energy conduction band to the LUMO of an analyte. The band gap may be tailored by functionalizing the luminescent polymer with groups that either donate or accept electron density, as described more fully below. For example, the luminescent polymer may be substituted with electron-donating groups to increase the electron density and raise the conduction band of the polymer.

FIG. 1 shows examples of some luminescent polymers that may be used in the determination of DMNB. Polymers P1-P3 are poly(aryleneethynylene)s comprising rigid, non-planar iptycene groups substituted with electron-donating alkoxy or disubstituted-amine groups. FIG. 2B shows a schematic representation of qualitative energy level diagrams of the valence bands and conduction bands of P1 and P3. As shown in FIG. 2B, dialkoxy-substituted polymer P1 has a larger band gap than diamino-substituted polymer P3. While increasing amine-substitution for polymers P1-P3 raises the energy of both the conduction band (e.g., LUMO) and the valence band (e.g., HOMO), the valence bands for polymers P1-P3 display greater increases in energy such that increasing amine-substitution results in a smaller band gap for P3, relative to P1 and P2.

In some embodiments, the band gap may be tailored by varying the three-dimensional structure of the luminescent polymer. For example, the luminescent polymer may comprise monomers which are non-planar with respect to adjacent monomers to produce a twisted backbone having a non-planar ground state conformation. The twisted or non-planar polymer backbone may lead to decreased conjugation and a higher energy conduction band. The twisting of the polymer backbone may be enhanced by employing monomers substituted with, for example, sterically large pendant groups, as described more fully below.

As an illustrative embodiment shown in FIG. 1, polymers P4-P7 are poly(phenylene)s that are optically blue-shifted relative to polymers P1-P3 due to a non-planar ground state conformation with decreased conjugation. In some cases, the more blue-shifted poly(phenylene)s may be quenched by DMNB with diffusion controlled rate constants. Also, increasing amine-substitution for polymers P4-P7 raises the valence band (e.g., HOMO) levels and has a smaller perturbation on the conduction band (e.g., LUMO) energies, which lowers the band gap.

In some cases, the luminescent polymer may be a poly(arylene), poly(arylenevinylene), poly(aryleneethynylene), or substituted derivatives thereof. In some embodiments, the luminescent polymer is a poly(aryleneethynylene). In some embodiments, the luminescent polymer is poly(arylene), such as poly(phenylene).

5 In one set of embodiments, additional determination methods may be used in combination with methods of the present invention. Confirmatory chemistry may be incorporated into a sensory device to discriminate DMNB from other potential quenchers. For example, in the presence of electromagnetic radiation DMNB may undergo reductive cleavage to generate a nitrite ion, which may be detected via a
10 colorimetric tests as known to those of ordinary skill in the art. Generation of the nitrite ion is generally unique to DMNB, relative to other quenching analytes (e.g., TNT), such that the identity of DMNB may be confirmed in addition to the determination of the presence and/or amount of analyte by luminescence quenching methods.

Another embodiment of the invention comprises methods for determining the
15 toxin hydrazine and other species comprising a hydrazine moiety. In some embodiments, the method comprises a "turn-on" detection mechanism, wherein the luminescent polymer is "quenched" in the absence of analyte and emits a luminescent signal in the presence of analyte. For example, a luminescent polymer may comprise
20 non-radiative pathways in the absence of analyte, resulting in a decreased luminescence emission. In the presence of hydrazine or the hydrazine derivative, the hydrazine or the hydrazine derivative can interact with the luminescent polymer to reduce the number of non-radiative pathways, thereby increasing the luminescence intensity of the material. Hydrazine derivatives may include alkyl-substituted hydrazines, other hydrazine-containing species, and the like.

25 As used herein, an excited-state molecule may return (e.g., "relax") to the ground state via a "non-radiative" pathway, in which the excitation energy is dissipated as energy other than electromagnetic radiation, such as heat, for example. In a "radiative" pathway, an excited-state molecule may return to the ground state by emitting the excitation energy as electromagnetic radiation (e.g., fluorescence emission). In some
30 cases, relaxation of an excited-state luminescent polymer can occur through a non-radiative pathway via the existence of a small number of oxidized sites within the polymer itself. In some cases, relaxation or quenching of an excited state can occur through a non-radiative pathway via interaction with a second molecule (e.g., a

quencher). For example, molecular oxygen or molecular iodine are efficient quenchers of fluorescence. The intentional introduction of iodine or oxygen as a reducible quencher and oxidant within a sample (e.g., film) of luminescent polymer may reduce the intensity of the background fluorescence signal in trace detection experiments.

5 Upon exposure to hydrazine (or hydrazine derivative) vapor, the quenched luminescent polymer may be "un-quenched" by reduction of either quenching molecules associated with the polymer and/or oxidized sites within the polymer itself to give large increases in luminescence intensity. This type of "unquenching" mechanism is essentially the reverse of amplified detection by fluorescence quenching of conjugated
10 polymer films in response to electron poor analytes.

In some cases, methods of the invention may be advantageous in that the hydrazine detection scheme relies upon reduction of the luminescent polymer as the transduction mechanism. That is, the hydrazine or hydrazine-containing species is a strong reducing agent capable of reducing the quencher molecule and/or oxidized sites of
15 a luminescent polymer at low concentrations, whereas other amines (e.g., ammonia), organic solvents (e.g., tetrahydrofuran, methanol, etc), or other common interferents of the hydrazine detection scheme may not be strong interferents at low concentrations. For example, exposure of a luminescent polymer to a 50 ppm concentration of ammonia gives a luminescence signal increase (20%) at least an order of magnitude less than that
20 observed with 1 ppm hydrazine.

In some embodiments, the luminescent polymer may be designed to interact with an analyte that is a strong reducing agent, such as hydrazine, by functionalizing the polymer with groups that donate electron density, such as amines, for example. Electron-rich luminescent polymers may be easily oxidized and may give large emission
25 enhancement upon exposure to hydrazine. FIG. 1 shows examples of some luminescent polymers that may be useful in the determination of hydrazine and hydrazine derivatives (e.g., P1-P3). Polymer P3, which is more electron-rich and more readily oxidized relative to polymer P1 and P2 may give larger on/off ratios upon exposure to hydrazine.

In addition, hydrazine vapor may be used to regenerate species which have been
30 oxidized or photobleached. For example, hydrazine exposure of functional conjugated polymer films (e.g. for explosives detection) that have lost a portion of their solid-state emission due to aging or photobleaching may allow for the extension of their useful lifetimes.

The present invention provides methods for increasing the luminescence intensity of a polymer, comprising exposing a luminescent polymer to hydrazine or the hydrazine derivative, wherein, in the absence of hydrazine or the hydrazine derivative, the luminescent polymer comprises non-radiative pathways, and, in the presence of hydrazine or the hydrazine derivative, hydrazine or the hydrazine derivative interacts with the luminescent polymer to reduce the number of non-radiative pathways, thereby increasing the luminescence intensity of the material.

In some cases, upon exposure to hydrazine or a hydrazine derivative, the luminescence intensity of the polymer increases by at least 25% relative to the luminescence intensity of the polymer in the absence of hydrazine or the hydrazine derivative upon exposure to the same conditions of electromagnetic radiation. In some cases, in the presence of hydrazine or the hydrazine derivative, the luminescence intensity increases by at least 50%, 75%, 100%, 250%, 500%, 750%, or 1000% relative to the luminescence intensity in the absence of hydrazine or the hydrazine derivative upon exposure to the same conditions of electromagnetic radiation.

As described herein, some embodiments of the present invention comprise the use of luminescent polymers as described herein for determination of an analyte. In some embodiments, the invention comprises the use of luminescent polymers for the determination of DMNB. In some embodiments, the invention comprises the use of luminescent polymers for the determination of hydrazine and hydrazine derivatives. It should be understood that the luminescent polymers as described herein may be useful in determination of one or more analytes.

For example, in one set of embodiments, the invention comprises the use of poly(arylene)s for the determination of DMNB. Some embodiments of the present invention comprise a luminescent polymer having the structure,

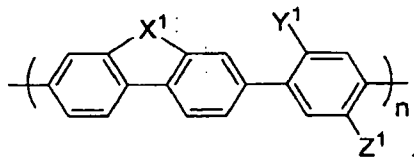

wherein X^1 is carbon or heteroatom, and X^1 optionally carries an alkyl substituent, Y^1 and Z^1 are independently hydrogen, alkyl, or heteroalkyl; and n is greater than 1. As used herein, "heteroatom" is given its ordinary meaning in the art and refers to an atom of any element other than carbon or hydrogen. Illustrative heteroatoms include boron, nitrogen, oxygen, phosphorus, sulfur and selenium, and alternatively oxygen, nitrogen or

sulfur. In some cases, the heteroatom is oxygen or nitrogen. In some embodiments, the heteroatom is nitrogen. In some embodiments, at least one of Y^1 and Z^1 is a dialkyl-substituted amine. In some embodiments, at least one of Y^1 and Z^1 is an alkoxy group. In a particular embodiment, X^1 is dialkyl-substituted carbon, Y^1 is hydrogen, and Z^1 is dialkyl-substituted amine. In another particular embodiment, X^1 is dialkyl-substituted carbon and Y^1 and Z^1 are dialkyl-substituted amine. FIG. 1 shows some examples of such polymers (e.g., polymers P5-P7).

Other embodiments of the present invention comprise a luminescent polymer having the structure,

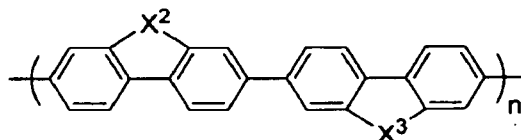

wherein X^2 and X^3 are independently carbon or heteroatom, and X^2 and X^3 optionally carry an alkyl substituent, and n is greater than 1. In one embodiment, X^2 and X^3 are dialkyl-substituted carbon. In one embodiment, X^2 is dialkyl-substituted carbon and X^3 is dialkyl-substituted amine. In one embodiment, X^2 and X^3 are dialkyl-substituted amine.

Some embodiments of the invention comprise the use of luminescent polymer for the determination of hydrazine and hydrazine derivatives. The luminescent polymer may have the structure,

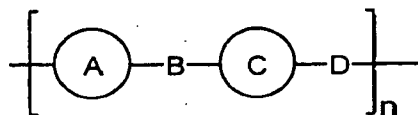

wherein n is at least 1, A and C are optionally substituted aromatic groups, and B and D are alkene, alkyne, heteroalkene, or heteroalkyne. In other embodiments of the invention, poly(phenylene ethynylene)s may be used, wherein B and D are alkynes.

In some cases, the luminescent polymer has the structure,

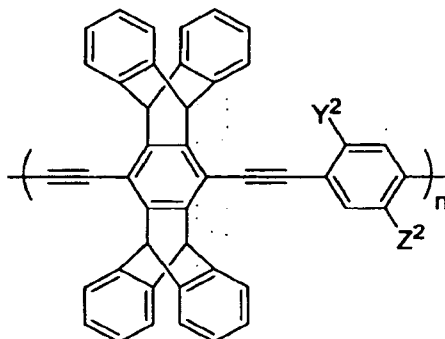

wherein Y^2 and Z^2 are independently alkyl, alkoxy, amino, and substituted derivatives thereof. In one embodiment, Y^2 and Z^2 are alkoxy. In another embodiment, Y^2 and Z^2 are NR^1R^2 , wherein R^1 and R^2 are alkyl. In another embodiment, Y^2 is hydrogen and Z^2 is NR^1R^2 , wherein R^1 and R^2 are alkyl. FIG. 1 shows some examples of such polymers (e.g., polymers P1-P3).

In some cases, the luminescent polymer may comprise one or more heterocycle groups, optionally substituted, within the polymer backbone and/or a pendant group to the polymer backbone. The heterocycle may be bonded to the polymer backbone (e.g., an aryl group of the polymer backbone), or a group that is pendant to the polymer backbone, via a carbon atom and/or a heteroatom. The term "heterocycle" is given its ordinary meaning in the art and refers to cyclic groups containing at least one heteroatom as a ring atom, such as oxygen, sulfur, nitrogen, phosphorus, and the like, as described more fully below. In some cases, the heterocycle is a nitrogen heterocycle, such as pyrazine, pyrimidine, pyrrole, or triazole. In some cases, the heterocycle is an oxygen heterocycle, such as furan or tetrahydrofuran.

In one set of embodiments, the luminescent polymer may comprise a triazole group, optionally substituted. In some cases, the luminescent polymer has a polymer backbone comprising a triazole group, optionally substituted. In some cases, the luminescent polymer comprises a pendant group comprising a triazole group, optionally substituted. The triazole group may be bonded to the luminescent polymer via a carbon atom and/or a nitrogen atom. For example, in some embodiments, the luminescent polymer has the structure,

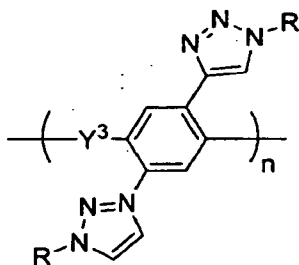

wherein Y^3 is alkene, alkyne, aryl, heteroalkene, heteroalkyne, or heteroaryl, optionally substituted; R is aryl or alkyl, optionally substituted; and n is greater than 1.

Luminescent polymers comprising heterocycles, as described herein, may be useful in the determination of analytes including DMNB, hydrazine, and hydrazine derivatives.

It should be understood that polymers of the invention may be further substituted with additional functional groups, as described herein.

As used herein, a "luminescent polymer" refers to a polymer that can absorb a quantum of electromagnetic radiation to cause the polymer to achieve an excited state structure. Luminescent polymers may also be capable of emitting radiation. Radiation can be emitted from the polymer or from a chromophore associated with (e.g., covalently bound to, non-covalently bound to, etc.) the polymer. The emitted radiation may be luminescence, in which "luminescence" is defined as an emission of ultraviolet or visible radiation. Specific types of luminescence include "fluorescence" in which a time interval between absorption and emission of visible radiation ranges from 10^{-12} to 10^{-7} s. "Chemiluminescence" refers to emission of radiation due to a chemical reaction, whereas "electrochemiluminescence" refers to emission of radiation due to electrochemical reactions. Typically, the extent of delocalized bonding allows the existence of a number of accessible electronic excited states. If the conjugation is so extensive so as to produce a near continuum of excited states, electronic excitations can involve a valence band, the highest fully occupied band, and a conduction band, often referred to as a band gap, as described herein.

Luminescent polymers may be used in various detection schemes for the determination of analytes. In some cases, the luminescent polymer may be used in a "turn-off" detection mechanism, wherein, in the presence of analyte, the excited state of a luminescent polymer interacts with the analyte via photoinduced electron transfer to "quench" the luminescence (e.g., fluorescence, phosphorescence, etc.) of the polymer. "Quenching" of luminescence may occur when a chromophore such as a luminescent

polymer in an excited state is exposed to an "acceptor" species that can absorb energy from the excited state chromophore. The excited state chromophore returns to a ground state due to nonradiative processes (i.e. without emitting radiation), resulting in a reduced quantum yield. A "quantum yield" refers to a number of photons emitted per adsorbed photon. Thus, the excited state chromophore can function as a "donor" species in that it transfers energy to the acceptor species. The acceptor species can be an external molecule (e.g., analyte) or an internal species such as another portion of the same polymer. For example, a "turn-off" detection method may be used to determine the presence and/or amount of DMNB, as described more fully below. Alternatively, the luminescent polymer may be used in a "turn-on" detection mechanism, wherein, in the absence of analyte, the luminescent polymer may exist in a quenched state and substantially no emission signal, or a significantly reduced emission signal, is observed. In the presence of analyte, the polymer may interact with the analyte to produce an emission. This process may be referred to as a "turn-on" luminescence detection method. For example, a "turn-on" detection method may be used to determine the presence and/or amount of hydrazine or derivatives of hydrazine, as described herein. In some cases, the "turn-on" fluorescence sensory scheme may be preferred since there are often fewer potential interferents that could cause a false positive with an emission increase or "turn-on" detection scheme.

Polymers, as used herein, refer to extended molecular structures comprising a backbone (e.g., non-conjugated backbone, conjugated backbone) which optionally contain pendant side groups, where "backbone" refers to the longest continuous bond pathway of the polymer. In one embodiment, at least a portion of the polymer is conjugated or pi-conjugated, i.e. the polymer has at least one portion along which electron density or electronic charge can be conducted, where the electronic charge is referred to as being "delocalized." Each p-orbital participating in conjugation can have sufficient overlap with adjacent conjugated p-orbitals. In one embodiment, at least a portion of the backbone is conjugated. In one embodiment, the entire backbone is conjugated and the polymer is referred to as a "conjugated polymer." Polymers having a conjugated pi-backbone capable of conducting electronic charge may be referred to as "conducting polymers." In some cases, the conjugated pi-backbone may be defined by a plane of atoms directly participating in the conjugation, wherein the plane arises from a preferred arrangement of the p-orbitals to maximize p-orbital overlap, thus maximizing

conjugation and electronic conduction. In some cases, the pi-backbone may preferably have a non-planar or twisted ground state conformation, leading to decreased conjugation and a higher energy conduction band.

In one embodiment, the polymer is selected from the group consisting of polyarylenes, polyarylene vinylenes, polyarylene ethynylenes and ladder polymers, i.e. polymers having a backbone that can only be severed by breaking two bonds. Examples of such polymers include polythiophene, polypyrrole, polyacetylene, polyphenylene and substituted derivatives thereof.

The luminescent polymers as described herein may be synthesized using known methods, such as those disclosed in Yang, et al., *J. Am. Chem. Soc.* **1998**, *120*, 12389; Thomas III, et al., *Macromolecules* **2005**, *38*, 2716; Morin, et al., *Macromolecules* **2001**, *34*, 4680, incorporated herein by reference. For example, FIG. 10 shows an illustrative embodiment of a synthetic scheme for synthesizing poly(phenylene ethynylene)s, wherein polymerization of a di-halide containing monomer and a diacetylene-containing monomer via a metal-catalyzed Sonogashira cross-coupling reaction can produce the polymer. Poly(phenylene)s may be synthesized using known methods, such as those disclosed in Lamba, et al., *J. Am. Chem. Soc.* **1994**, *116*, 11723 and Bredas, et al., *Polym. Prepr. (Am. Chem. Soc., Div. Polym. Chem.)* **1994**, *35*, 185, incorporated herein by reference.

The properties of the luminescent polymers may also be tuned based on the substitution of the conjugated polymer backbone. Those skilled in the art would recognize what types of functional groups would afford a particular, desired property, such as a particular band gap, as described herein, or a specific emission wavelength. For example, the polymer may be substituted with electron-poor groups, such as acyl, carboxyl, cyano, nitro, sulfonate, or the like, or the polymer may install electron-poor aryl groups in the backbone of the polymer, such that the polymer exhibits fluorescence emission at shorter wavelengths. In other embodiments, the monomers may be substituted with electron-rich groups, such as amino, hydroxy, alkoxy, acylamino, acyloxy, alkyl, halide, and the like, or the monomers may install electron-rich aryl groups in the backbone of the polymer, such that the polymer exhibits fluorescence emission at longer wavelengths. FIG. 11 shows several illustrative embodiments for the synthesis of electron-rich monomers containing amine groups. In some embodiments, the polymer may be tailored to advantageously have a large Stokes shift, wherein the

fluorescence spectrum is observed at a substantially longer wavelength than the excitation spectrum. In some embodiments, an electron-rich monomer may be copolymerized with an electron-poor monomer to produce polymers having longer wavelength emission.

5 In some embodiments, the conjugated polymer or oligomer comprises a sterically bulky monomer that may aid in preserving the optical properties of the polymer or oligomer, even in the solid state. That is, the use of sterically bulky monomers may prevent adjacent or nearby neighboring molecules from interacting with each other through, for example, pi-stacking, to cause a decrease in emission. In some cases, the
10 bulky monomer may comprise a non-planar, bicyclic group that is rigidly attached to the polymer backbone, wherein the bicyclic group comprises bridgehead atoms that are not adjacent to one another. A "rigid" group refers to a group that does not easily rotate about a bond axis, preferably a bond that binds the rigid group to the polymer. In one embodiment, the rigid group rotates no more than about 180°, preferably no more than
15 about 120° and more preferably no more than about 60°. Certain types of rigid groups can provide a polymer with a backbone separated from an adjacent backbone at a distance of at least about 4.5 Å and more preferably at least about 5.0 Å. In one embodiment, the rigid groups are incorporated as pendant groups. Examples of bulky monomers may include monomers comprising surfactants, proteins, or sterically large
20 and/or non-planar organic groups such as pentyptycenes having five arene planes, triptycenes having three arene planes, or other iptycene and iptycene-related moieties. By minimizing the intermolecular pi-pi interactions between nearby or adjacent polymers, the shape of the emission spectra may remain substantially the same as the conjugated polymers are formed into particles or are aggregated in the solid-state.

25 It is an advantageous feature of the present invention to provide luminescent polymers having a molecular structure that reduces pi-stacking interactions, resulting in increased quantum yields and/or luminescence lifetimes. It is particularly advantageous that these enhanced properties can be achieved when the polymer is provided as a solid state material, e.g. a film. In one embodiment, the film comprising a luminescent
30 polymer has a quantum yield of at least about 0.05 times the quantum yield of the luminescent polymer in solution, more preferably at least about 0.1 times the quantum yield of the luminescent polymer in solution, more preferably at least about 0.15 times the quantum yield of the luminescent polymer in solution, more preferably at least about

0.2 times the quantum yield of the luminescent polymer in solution, more preferably at least about 0.25 times the quantum yield of the luminescent polymer in solution, more preferably at least about 0.3 times the quantum yield of the luminescent polymer in solution, more preferably at least about 0.4 times the quantum yield of the luminescent polymer in solution, and more preferably still about 0.5 times the quantum yield of the luminescent polymer in solution.

The polymer can be a homo-polymer or a co-polymer such as a random co-polymer or a block co-polymer. In one embodiment, the polymer is a block co-polymer. An advantageous feature of block co-polymers is that they may mimic a multi-layer structure, wherein each block may be designed to have different band gap components and, by nature of the chemical structure of a block co-polymer, each band gap component is segregated. As described herein, the band gap and/or selectivity for particular analytes can be achieved by modification or incorporation of different polymer types. The polymer compositions can vary continuously to give a tapered block structure and the polymers can be synthesized by either step growth or chain growth methods.

As used herein, the term "alkyl" refers to the radical of saturated aliphatic groups, including straight-chain alkyl groups, branched-chain alkyl groups, cycloalkyl (alicyclic) groups, alkyl substituted cycloalkyl groups, and cycloalkyl substituted alkyl groups. The alkyl groups may be optionally substituted with additional groups, as described further below. Examples of alkyl groups include, but are not limited to, methyl, ethyl, propyl, isopropyl, cyclopropyl, butyl, isobutyl, tert-butyl, cyclobutyl, hexyl, cyclohexyl, and the like.

The term "heteroalkyl" refers to an alkyl group as described herein in which one or more carbon atoms is replaced by a heteroatom. Suitable heteroatoms include oxygen, sulfur, nitrogen, phosphorus, and the like. Examples of heteroalkyl groups include, but are not limited to, alkoxy, amino, thioester, and the like.

The terms "alkene" and "alkyne" refer to unsaturated aliphatic groups analogous in length and possible substitution to the alkyls described above, but that contain at least one double or triple bond respectively.

The terms "heteroalkene" and "heteroalkyne" refer to unsaturated aliphatic groups analogous in length and possible substitution to the heteroalkyls described above, but that contain at least one double or triple bond respectively.

As used herein, the term "halogen" or "halide" designates -F, -Cl, -Br or -I.

The term "aryl" refers to aromatic carbocyclic groups, optionally substituted, having a single ring (e.g., phenyl), multiple rings (e.g., biphenyl), or multiple fused rings in which at least one is aromatic (e.g., 1,2,3,4-tetrahydronaphthyl, naphthyl, anthryl, or phenanthryl). That is, at least one ring may have a conjugated pi electron system, while
5 other, adjoining rings can be cycloalkyls, cycloalkenyls, cycloalkynyls, aryls and/or heterocyclyls. The aryl group may be optionally substituted, as described herein.

"Carbocyclic aryl groups" refer to aryl groups wherein the ring atoms on the aromatic ring are carbon atoms. Carbocyclic aryl groups include monocyclic carbocyclic aryl groups and polycyclic or fused compounds (e.g., two or more adjacent ring atoms are
10 common to two adjoining rings) such as naphthyl groups.

The terms "heteroaryl" refers to aryl groups comprising at least one heteroatom as a ring atom.

As described herein, the term "heterocycle" refers to cyclic groups containing at least one heteroatom as a ring atom, in some cases, 1 to 3 heteroatoms as ring atoms,
15 with the remainder of the ring atoms being carbon atoms. Suitable heteroatoms include oxygen, sulfur, nitrogen, phosphorus, and the like. The term "heterocycle" may include heteroaryl groups, saturated heterocycles (e.g., cycloheteroalkyl) groups, or combinations thereof. The heterocycle may be a saturated molecule, or may comprise one or more double bonds. In some case, the heterocycle is a nitrogen heterocycle,
20 wherein at least one ring comprises at least one nitrogen ring atom. The heterocycles may be fused to other rings to form a polycyclic heterocycle. The heterocycle may also be fused to a spirocyclic group. In some cases, the heterocycle may be attached to a compound via a nitrogen or a carbon atom in the ring.

Heterocycles include, for example, thiophene, benzothiophene, thianthrene,
25 furan, tetrahydrofuran, pyran, isobenzofuran, chromene, xanthene, phenoxathiin, pyrrole, dihydropyrrole, pyrrolidine, imidazole, pyrazole, pyrazine, isothiazole, isoxazole, pyridine, pyrazine, pyrimidine, pyridazine, indolizine, isoindole, indole, indazole, purine, quinolizine, isoquinoline, quinoline, phthalazine, naphthyridine, quinoxaline, quinazoline, cinnoline, pteridine, carbazole, carboline, triazole, tetrazole, oxazole,
30 isoxazole, thiazole, isothiazole, phenanthridine, acridine, pyrimidine, phenanthroline, phenazine, phenarsazine, phenothiazine, furazan, phenoxazine, pyrrolidine, oxolane, thiolane, oxazole, oxazine, piperidine, homopiperidine (hexamethyleneimine), piperazine (e.g., N-methyl piperazine), morpholine, lactones, lactams such as

azetidinones and pyrrolidinones, sultams, sultones, other saturated and/or unsaturated derivatives thereof, and the like. The heterocyclic ring can be optionally substituted at one or more positions with such substituents as described herein. In some cases, the heterocycle may be bonded to a compound via a heteroatom ring atom. In some cases, the heterocycle may be bonded to a compound via a carbon ring atom. In some cases, the heterocycle is pyrrolidine, piperidine, or morpholine.

The term "alkoxy" refers to the group, O-alkyl.

The terms "amine" and "amino" are art-recognized and refer to both unsubstituted and substituted amines, e.g., a moiety that can be represented by the general formula: $N(R')(R'')(R''')$ wherein R' , R'' , and R''' each independently represent a group permitted by the rules of valence.

As used herein, the term "substituted" is contemplated to include all permissible substituents of organic compounds, "permissible" being in the context of the chemical rules of valence known to those of ordinary skill in the art. It will be understood that "substituted" also includes that the substitution results in a stable compound, e.g., which does not spontaneously undergo transformation such as by rearrangement, cyclization, elimination, etc. In some cases, "substituted" may generally refer to replacement of a hydrogen with a substituent as described herein. However, "substituted," as used herein, does not encompass replacement and/or alteration of a key functional group by which a molecule is identified, e.g., such that the "substituted" functional group becomes, through substitution, a different functional group. For example, a "substituted phenyl" group must still comprise the phenyl moiety and can not be modified by substitution, in this definition, to become, e.g., a pyridine ring. In a broad aspect, the permissible substituents include acyclic and cyclic, branched and unbranched, carbocyclic and heterocyclic, aromatic and nonaromatic substituents of organic compounds. Illustrative substituents include, for example, those described herein. The permissible substituents can be one or more and the same or different for appropriate organic compounds. For purposes of this invention, the heteroatoms such as nitrogen may have hydrogen substituents and/or any permissible substituents of organic compounds described herein which satisfy the valencies of the heteroatoms.

Examples of substituents include, but are not limited to, halogen, azide, alkyl, aralkyl, alkenyl, alkynyl, cycloalkyl, hydroxyl, alkoxy, amino, nitro, sulfhydryl, imino, amido, phosphonate, phosphinate, carbonyl, carboxyl, silyl, ether, alkylthio, sulfonyl,

sulfonamido, ketone, aldehyde, ester, heterocyclyl, aromatic or heteroaromatic moieties, -CF₃, -CN, aryl, aryloxy, perhaloalkoxy, aralkoxy, heteroaryl, heteroaryloxy, heteroarylalkyl, heteroaralkoxy, azido, amino, halide, alkylthio, oxo, acylalkyl, carboxy esters, -carboxamido, acyloxy, aminoalkyl, alkylaminoaryl, alkylaryl, alkylaminoalkyl, alkoxyaryl, arylamino, aralkylamino, alkylsulfonyl, -carboxamidoalkylaryl, -carboxamidoaryl, hydroxyalkyl, haloalkyl, alkylaminoalkylcarboxy-, aminocarboxamidoalkyl-, cyano, alkoxyalkyl, perhaloalkyl, arylalkyloxyalkyl, and the like.

While several embodiments of the present invention have been described and illustrated herein, those of ordinary skill in the art will readily envision a variety of other means and/or structures for performing the functions and/or obtaining the results and/or one or more of the advantages described herein, and each of such variations and/or modifications is deemed to be within the scope of the present invention. More generally, those skilled in the art will readily appreciate that all parameters, dimensions, materials, and configurations described herein are meant to be exemplary and that the actual parameters, dimensions, materials, and/or configurations will depend upon the specific application or applications for which the teachings of the present invention is/are used. Those skilled in the art will recognize, or be able to ascertain using no more than routine experimentation, many equivalents to the specific embodiments of the invention described herein. It is, therefore, to be understood that the foregoing embodiments are presented by way of example only and that, within the scope of the appended claims and equivalents thereto, the invention may be practiced otherwise than as specifically described and claimed. The present invention is directed to each individual feature, system, article, material, kit, and/or method described herein. In addition, any combination of two or more such features, systems, articles, materials, kits, and/or methods, if such features, systems, articles, materials, kits, and/or methods are not mutually inconsistent, is included within the scope of the present invention.

The indefinite articles "a" and "an," as used herein in the specification and in the claims, unless clearly indicated to the contrary, should be understood to mean "at least one."

The phrase "and/or," as used herein in the specification and in the claims, should be understood to mean "either or both" of the elements so conjoined, i.e., elements that are conjunctively present in some cases and disjunctively present in other cases. Other

elements may optionally be present other than the elements specifically identified by the “and/or” clause, whether related or unrelated to those elements specifically identified unless clearly indicated to the contrary. Thus, as a non-limiting example, a reference to “A and/or B”, when used in conjunction with open-ended language such as “comprising”
5 can refer, in one embodiment, to A without B (optionally including elements other than B); in another embodiment, to B without A (optionally including elements other than A); in yet another embodiment, to both A and B (optionally including other elements); etc.

As used herein in the specification and in the claims, “or” should be understood to have the same meaning as “and/or” as defined above. For example, when separating
10 items in a list, “or” or “and/or” shall be interpreted as being inclusive, i.e., the inclusion of at least one, but also including more than one, of a number or list of elements, and, optionally, additional unlisted items. Only terms clearly indicated to the contrary, such as “only one of” or “exactly one of,” or, when used in the claims, “consisting of,” will refer to the inclusion of exactly one element of a number or list of elements. In general,
15 the term “or” as used herein shall only be interpreted as indicating exclusive alternatives (i.e. “one or the other but not both”) when preceded by terms of exclusivity, such as “either,” “one of,” “only one of,” or “exactly one of.” “Consisting essentially of”, when used in the claims, shall have its ordinary meaning as used in the field of patent law.

As used herein in the specification and in the claims, the phrase “at least one,” in
20 reference to a list of one or more elements, should be understood to mean at least one element selected from any one or more of the elements in the list of elements, but not necessarily including at least one of each and every element specifically listed within the list of elements and not excluding any combinations of elements in the list of elements. This definition also allows that elements may optionally be present other than the
25 elements specifically identified within the list of elements to which the phrase “at least one” refers, whether related or unrelated to those elements specifically identified. Thus, as a non-limiting example, “at least one of A and B” (or, equivalently, “at least one of A or B,” or, equivalently “at least one of A and/or B”) can refer, in one embodiment, to at least one, optionally including more than one, A, with no B present (and optionally
30 including elements other than B); in another embodiment, to at least one, optionally including more than one, B, with no A present (and optionally including elements other than A); in yet another embodiment, to at least one, optionally including more than one,

A, and at least one, optionally including more than one, B (and optionally including other elements); etc.

In the claims, as well as in the specification above, all transitional phrases such as “comprising,” “including,” “carrying,” “having,” “containing,” “involving,” “holding,” and the like are to be understood to be open-ended, i.e., to mean including but not limited to. Only the transitional phrases “consisting of” and “consisting essentially of” shall be closed or semi-closed transitional phrases, respectively, as set forth in the United States Patent Office Manual of Patent Examining Procedures, Section 2111.03.

EXAMPLES

Example 1

In order to select optimally sensitive and operationally useful luminescent polymers for the detection of DMNB, polymers were designed to have electronic structures having greater photoreduction abilities. FIG. 2B illustrates qualitative energy level diagrams of the materials used in these experiments. Table 1 lists the Stern-Volmer constants [$k(sv)$] and quenching rate constants [$k(q)$] from Stern-Volmer experiments with these luminescent polymers with DMNB as the quencher. The variation in the quenching efficiency of the poly(phenylene ethynylene)s (PPEs, P1-3) revealed that the factors controlling the quenching rate constants are multifaceted. Although the pi-donation of the amines reduces the ground state oxidation potential for P3, it also lowers the band gap and thereby reduces the magnitude of P3's excited-state reduction potential. The higher quenching efficiency of P2, with only one amine per repeat unit, is likely due to a balance between these two effects. All of the PPEs investigated showed very poor quenching rate constants, with even the best quenching rate constant falling an order of magnitude less than the diffusion controlled limit.

Table 1 – DMNB Stern-Volmer Data

Polymer	$\lambda(em)$	$\tau(f)$	$k(sv) (M^{-1})$	$k(q) (10^9 M^{-1} s^{-1})$
P1	460 nm	0.6 ns	~ 0	< 1
P2	475 nm	1.8 ns	3.4	1.9
P3	580 nm	3.9 ns	< 2	< 1
P4	416 nm	0.5 ns	9.2	18
P5	413 nm	0.6 ns	9.0	15
P6	452 nm	1.9 ns	13	6.9
P7	512 nm	4.2 ns	22	5.2

In order to increase the excited-state reduction potential and thereby improve the efficacy of the quenching reaction, larger band gap poly(phenylene)s (PPs, P4-P7) were designed and prepared. Polymers P4-P7 are optically blue-shifted relative to polymers P1-P3, due to a non-planar ground state conformation with decreased conjugation. All the PPs investigated gave quenching rate constants significantly higher than P2, the PPE most efficiently quenched by DMNB, supporting the concept that larger band gaps, and therefore higher energy conduction bands, may produce superior performance relative to analogous PPEs. In fact the most blue-shifted PPs are quenched by DMNB with diffusion controlled pseudo-first order rate constants. As would be expected from simple orbital mixing arguments the aryl amines mainly raise the valence band (HOMO) levels and have a smaller perturbation on the conduction band (LUMO) energies, which lowers the band gaps for both PPEs and PPs. The PPs' wider band gap enables more exergonic electron transfer from the higher energy conduction bands to the DMNB LUMO.

Satisfying the energetic constraints of electron transfer quenching is a necessary, but not a sufficient condition for the trace detection of vapor phase analytes with solid-state AFPs.

The degree of fluorescence quenching of polymers in the solid state by DMNB is also dependent upon other factors, such as the vapor pressure of the analyte, its binding constant to the fluorescent polymer film, and the mobility of excitons within polymers in the solid-state.

Example 2

The ability of luminescent polymers to detect DMNB vapor was studied. Thin films of selected luminescent polymers were simultaneously irradiated and exposed to equilibrium vapor pressures of DMNB. In order to probe the effect of analyte molecular shape, benzophenone was also investigated as a vapor phase quencher. Benzophenone has a reduction potential (-1.6 V vs. SCE) similar to that of DMNB as well as a similar equilibrium vapor pressure (1.93×10^{-3} torr at 25 °C). In contrast to DMNB, the flat structure of benzophenone could allow for strong pi-stacking with the polymer film.

The experiments were carried out on a commercial Fido™ instrument manufactured by Nomadics Inc., which continuously monitors the total fluorescence during vapor sampling.

Upon exposure to DMNB vapor, solid-state fluorescence quenching by the PPEs was observed to be very weak relative to the PPs, with only P2 giving a 4-5% fluorescence attenuation in the presence of DMNB vapor.

FIG. 3 shows the fluorescence emission intensity response of a thin film of P5 to repeated variable time exposures to equilibrium DMNB vapor.

Table 2 summarizes the results of the solid-state quenching experiments. The percentage of quenching due to equilibrium benzophenone vapor correlates well with the electron density on the polymer chain, with the diamine-containing P7 showing an average response of 60% quenching under constant flow. These results are consistent with strong polymer-analyte pi-stacking, since polymers with more electron-rich pi systems will have a higher affinity for the more planar benzophenone. The larger binding affinity of benzophenone is also revealed in its temporal response in the sensor. The sensor response in FIG. 3 shows that, at short exposure times, the binding interaction between the polymer and DMNB is highly reversible, indicating a weak binding (rapid off-rate).

FIG. 4 shows the fluorescence emission intensity response of a thin film of P5 upon a ~20 s exposure to equilibrium vapor of either (a) DMNB or (b) benzophenone. The 20 second exposures to either benzophenone or DMNB (FIG. 4) are illustrative of the slower recovery times associated with benzophenone that indicate stronger binding constants with the luminescent polymers. The larger binding affinity of benzophenone for the very electron-rich P7 versus P6 or other, less-electron rich polymers is large enough to outweigh any other factors that might make P7 less efficient, such as a smaller driving force for electron transfer or decreased exciton mobility.

Table 2 – Solid-State Quenching Percentages		
<u>Poly</u>	<u>Benzophenone</u>	<u>DMNB</u>
P4	5 ± 1%	6 ± 1%
P5	29 ± 3%	20 ± 5%
P6	38 ± 3%	12 ± 3%
P7	58 ± 7%	4 ± 1%

As shown by the data in Table 2, the moderately electron-rich polymer P5 gave a highly reversible and rapid quenching response of about 20%. More electron-rich and more electron-poor polymers gave smaller responses, which may be indicative of several competing factors contributing to the observed results. For example, electrostatic attraction may be a factor in the solid-state detection of DMNB, since on an absolute scale it is an electron-deficient compound. However, DMNB generally does not form strong pi-stacking interactions, and its binding differences may not, or may only be slightly, affected by the electron density in the pi-system of the polymers described herein.

Other parameters that can affect a particular material's quenching efficiency in response to an analyte vapor include the rate of PICT, which was demonstrated in the solution experiments to be smaller for the amine-substituted PPs. In addition, the mobility of the excitons in films of P6 and P7 may be substantially smaller than for P5. The large Stokes shift and excited state lifetimes of these materials can be indicative of a substantial structural rearrangement in the excited state. The inability of certain polymer chains to adopt the preferred conformation in the solid-state and the activated nature of conformational changes may impose a "viscous drag" and produce excitons with an higher effective mass.

The efficient detection of very weakly binding analytes may rely on the balance of the parameters described above. In some embodiments, P5 offers a good balance of PICT driving force, electrostatic attraction, and exciton mobility to give a reversible and rapid response to DMNB vapor. In addition, P5, which has previously been investigated for potential use as blue emitter in PLEDs, is highly emissive in the solid state and shows good photochemical stability, especially compared to the amine-containing poly(phenylene)s P6 and P7.

Example 3

Both the solution and solid-state luminescence response of polymers P1b, P2, and P3 to hydrazine vapor was investigated.

UV/vis spectra were recorded on an Agilent 8453 diode-array spectrophotometer and corrected for background signal with a solvent-filled cuvette for solution measurements or a blank cover slip (for solid-state measurements). Emission spectra were acquired on a SPEX Fluorolog- τ 3 fluorimeter (model FL-321, 450 W Xenon lamp).

using front-face detection for all film samples. Hydrazine hydrate and iodine were purchased from Aldrich and used as received.

The preparation and characterization of polymers investigated in this study has been previously described in Yang, et al., *J. Am. Chem. Soc.* **1998**, *120*, 12389;
5 Thomas III, et al., *Macromolecules* **2005**, *38*, 2716, incorporated herein by reference.

For solid-state spectroscopy, thin films were spun-cast onto glass cover slips from an approximately 1 mg/mL chloroform solution at 1500-3000 rpm. Experiments involving equilibrium vapor pressure hydrazine were performed by using a 20-mL size vial that included a piece of cotton and approximately 3 drops of hydrazine hydrate. For
10 spectral responses, this vial was held up to the surface of the film for several seconds. A similar procedure was followed for iodine doping.

Example 4

The temporal responses of the emission signals of films of P1b, P2, and P3 to hydrazine vapor were measured using a FIDO sensing platform manufactured by
15 Nomadics, Inc. The inside of a glass capillary was coated with the conjugated polymer film (spun-cast from a 1 mg/mL solution (THF or CHCl₃ at 700 rpm for 1 minute). This capillary was inserted into the sensor, which is equipped with a laser diode (405 nm) and a photodetector. In addition, a pump, operating at 30-60 cc/min, draws in air from a nozzle through the capillary, exposing the film to an analyte vapor of the users choice. (In
20 this work hydrazine or iodine). The total emission is then continuously monitored. Equilibrium concentrations of vapors were introduced by manually holding a vial (20 mL size) that contains some of the analyte solid and a piece of cotton up to the nozzle of the Fido device. Trace concentrations of hydrazine were introduced to the Fido by
25 flowing a known rate of dry nitrogen gas (using a flow meter) through a chamber with controllable temperature. This chamber contained a disposable hydrazine permeation tube (Kin-Tek Laboratories) with a known rate of diffusion. By adjusting the rate of gas flow over the permeation tube, the trace concentration of hydrazine in the gas flow could be accurately changed. Films used for trace hydrazine detection were first irradiated
30 with the Fido light source until they achieved a stable baseline, which typically resulted in an overall weakening of the fluorescence signal. Iodine doping in Fido experiments was achieved by presenting a vial of iodine crystals to the instrument.

FIG. 5 shows the emission spectra of P3 (a) before and (b) after exposure to a equilibrium vapor of hydrazine for 10 seconds. No new emitting species was observed

capillary and analyzed in a FIDO sensory platform. The FIDO device allowed for the collection of fluorescence intensity data of a thin film while exposed to a continuous flow of analyte vapor. Low concentrations of hydrazine analyte were generated by flowing nitrogen gas past a heated permeation tube with a known rate of hydrazine diffusion. Adjusting the flow rate of N₂ allowed for the preparation of a dilute gas-phase sample of hydrazine with a known concentration.

FIG. 6 shows the time-dependent emission of a photobleached film of P2 in a FIDO sensing platform exposed to 1 ppm (permissible exposure limit) hydrazine vapor for 60 sec. As observed in FIG. 6, the emission intensity increased upon exposure to hydrazine vapor. Such "turn-on" signals have been observed at concentrations as low as 100 parts-per-billion (10% of the permissible exposure limit) hydrazine vapor.

Example 6

The effect of hydrazine on the luminescence intensity of the polymers was also studied by first forming I₂-doped films of polymers, wherein molecular iodine was a sacrificial oxidant, to trace hydrazine detection. The I₂-doped films were then exposed to trace hydrazine vapor as described in Example 5. FIG. 7 shows the UV/vis spectra of a film of P3 (a) before exposure to I₂ vapor, (b) after exposure to I₂ vapor, and (c) after exposure of the I₂-doped film to saturated hydrazine vapor for 5 seconds. Exposure to I₂ resulted in a significant spectral change of P3, whereas the polymers that are more difficult to oxidize (P1 and P2) showed no evidence of chemical reaction with I₂.

The intentional inclusion of traps by I₂ doping gave a system with a much lower background signal while maintaining the amplified nature of the transduction. Polymers P1-P3 all showed almost complete fluorescence quenching upon exposure to saturated I₂ vapor. The observed fluorescence quenching of P1 and P2 by I₂ vapor was likely due to intercalation of I₂ rather than chemical oxidation. FIG. 8 shows the emission response of polymer P2 (a) before exposure to I₂, (c) after exposure to I₂ for approximately 5 seconds, and (b) after exposure of the I₂-doped film to hydrazine vapor, and (d) the fluorescence trace of the I₂-doped film exposed to 1 ppm hydrazine. The on/off ratio of this sensory material was much larger than with the pure (e.g., non-I₂-doped) polymer, since the intercalated iodine had almost completely quenched the emission of the film. In this example there was a fluorescence enhancement of almost one order of magnitude within five minutes.

As shown in FIG. 8, exposure of the oxidized P2 to saturated hydrazine vapor resulted in a nearly full recovery of solid-state emission with identical spectral shape by reduction of oxidized polymer chains and intercalated iodine. FIG. 9 shows a plot of normalized emission intensity of a film of P3 as a function of time upon exposure to saturated iodine vapor (quench) followed by saturated hydrazine vapor (recovery), illustrating the reproducibility of the process over multiple iodine/hydrazine exposure cycles.

While several embodiments of the present invention have been described and illustrated herein, those of ordinary skill in the art will readily envision a variety of other means and/or structures for performing the functions and/or obtaining the results and/or one or more of the advantages described herein, and each of such variations and/or modifications is deemed to be within the scope of the present invention. More generally, those skilled in the art will readily appreciate that all parameters, dimensions, materials, and configurations described herein are meant to be exemplary and that the actual parameters, dimensions, materials, and/or configurations will depend upon the specific application or applications for which the teachings of the present invention is/are used. Those skilled in the art will recognize, or be able to ascertain using no more than routine experimentation, many equivalents to the specific embodiments of the invention described herein. It is, therefore, to be understood that the foregoing embodiments are presented by way of example only and that, within the scope of the appended claims and equivalents thereto, the invention may be practiced otherwise than as specifically described and claimed. The present invention is directed to each individual feature, system, article, material, kit, and/or method described herein. In addition, any combination of two or more such features, systems, articles, materials, kits, and/or methods, if such features, systems, articles, materials, kits, and/or methods are not mutually inconsistent, is included within the scope of the present invention.

The indefinite articles "a" and "an," as used herein in the specification and in the claims, unless clearly indicated to the contrary, should be understood to mean "at least one."

The phrase "and/or," as used herein in the specification and in the claims, should be understood to mean "either or both" of the elements so conjoined, i.e., elements that are conjunctively present in some cases and disjunctively present in other cases. Other elements may optionally be present other than the elements specifically identified by the

“and/or” clause, whether related or unrelated to those elements specifically identified unless clearly indicated to the contrary. Thus, as a non-limiting example, a reference to “A and/or B”, when used in conjunction with open-ended language such as “comprising” can refer, in one embodiment, to A without B (optionally including elements other than B); in another embodiment, to B without A (optionally including elements other than A);
5 B); in yet another embodiment, to both A and B (optionally including other elements); etc.

As used herein in the specification and in the claims, “or” should be understood to have the same meaning as “and/or” as defined above. For example, when separating items in a list, “or” or “and/or” shall be interpreted as being inclusive, i.e., the inclusion
10 of at least one, but also including more than one, of a number or list of elements, and, optionally, additional unlisted items. Only terms clearly indicated to the contrary, such as “only one of” or “exactly one of,” or, when used in the claims, “consisting of,” will refer to the inclusion of exactly one element of a number or list of elements. In general, the term “or” as used herein shall only be interpreted as indicating exclusive alternatives
15 (i.e. “one or the other but not both”) when preceded by terms of exclusivity, such as “either,” “one of,” “only one of,” or “exactly one of.” “Consisting essentially of”, when used in the claims, shall have its ordinary meaning as used in the field of patent law.

As used herein in the specification and in the claims, the phrase “at least one,” in reference to a list of one or more elements, should be understood to mean at least one
20 element selected from any one or more of the elements in the list of elements, but not necessarily including at least one of each and every element specifically listed within the list of elements and not excluding any combinations of elements in the list of elements. This definition also allows that elements may optionally be present other than the elements specifically identified within the list of elements to which the phrase “at least
25 one” refers, whether related or unrelated to those elements specifically identified. Thus, as a non-limiting example, “at least one of A and B” (or, equivalently, “at least one of A or B,” or, equivalently “at least one of A and/or B”) can refer, in one embodiment, to at least one, optionally including more than one, A, with no B present (and optionally including elements other than B); in another embodiment, to at least one, optionally
30 including more than one, B, with no A present (and optionally including elements other than A); in yet another embodiment, to at least one, optionally including more than one, A, and at least one, optionally including more than one, B (and optionally including other elements); etc.

In the claims, as well as in the specification above, all transitional phrases such as “comprising,” “including,” “carrying,” “having,” “containing,” “involving,” “holding,” and the like are to be understood to be open-ended, i.e., to mean including but not limited to. Only the transitional phrases “consisting of” and “consisting essentially of” shall be
5 closed or semi-closed transitional phrases, respectively, as set forth in the United States Patent Office Manual of Patent Examining Procedures, Section 2111.03.

What is claimed:

1. A method for determination of 2,3-dimethyl-2,3-dinitrobutane (DMNB),
comprising:

exposing a luminescent polymer to a sample suspected of containing DMNB,
wherein DMNB, if present, interacts with the luminescent polymer to cause a change in
5 the luminescence of the polymer; and

determining the change in the luminescence of the polymer, thereby determining
DMNB.

2. A method as in claim 1, wherein the change comprises a decrease in
10 luminescence intensity.

3. A method as in claim 1, wherein the change comprises an increase in
luminescence intensity.

4. A method as in claim 1, wherein the change comprises a change in the
15 wavelength of the luminescence.

5. A method as in claim 1, wherein the change is caused by a photoinduced charge
transfer reaction between the luminescent polymer and DMNB.

6. A method as in claim 1, further comprising:
treating the DMNB to produce a nitrite ion; and
determining the presence of the nitrite ion, thereby determining the identity of
20 DMNB.

7. A method as in claim 6, wherein the DMNB is determined by colorimetric
25 methods.

8. A method as in claim 6, wherein the treating comprises exposure to
30 electromagnetic radiation.

9. A method as in claim 1, wherein the luminescent polymer comprises a first monomer and a second monomer, wherein the first monomer is non-planar with respect to the second monomer.

5 10. A method as in claim 1, wherein the luminescent polymer is a poly(arylene), poly(arylenevinylene), poly(aryleneethynylene), and substituted derivatives thereof.

11. A method as in claim 1, wherein the luminescent polymer is poly(arylene).

10 12. A method as in claim 1, wherein the luminescent polymer is poly(phenylene).

13. A method as in claim 1, wherein the luminescent polymer has the structure,

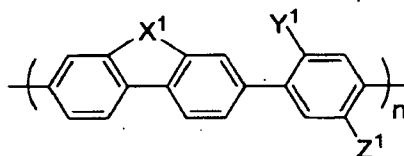

15 wherein X¹ is carbon or heteroatom, and X¹ optionally carries an alkyl substituent, Y and Z are independently hydrogen, alkyl, or heteroalkyl; and n is greater than 1.

14. A method as in claim 13, wherein the luminescent polymer has the structure,

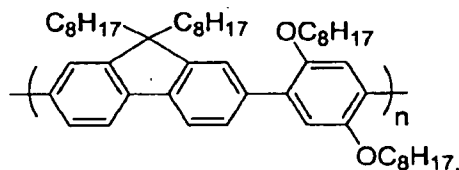

20 15. A method as in claim 13, wherein the luminescent polymer has the structure,

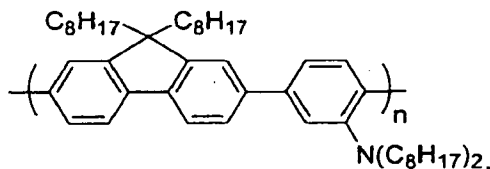

16. A method as in claim 13, wherein the luminescent polymer has the structure,

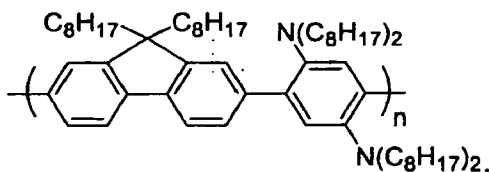

17. A method as in claim 1, wherein the luminescent polymer has the structure,

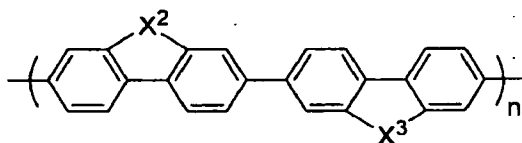

5 wherein X² and X³ are independently carbon or heteroatom, and X² and X³ optionally carry an alkyl substituent, and n is greater than 1.

18. A method as in claim 17, wherein the luminescent polymer has the structure,

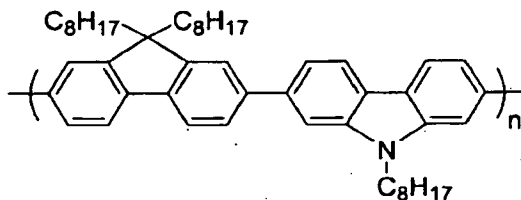

10

19. A method as in claim 17, wherein the luminescent polymer has the structure,

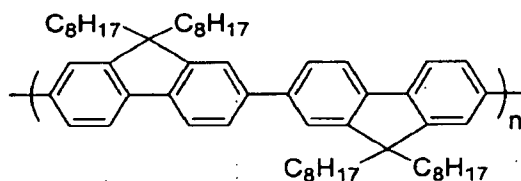

15 20. A method as in claim 1, wherein the luminescent polymer comprises a heterocycle, optionally substituted.

21. A method as in claim 1, wherein the luminescent polymer comprises a triazole group, optionally substituted.

20 22. A method as in claim 1, wherein the luminescent polymer comprises a pendant group comprising a triazole group, optionally substituted.

23. A method as in claim 1, wherein the luminescent polymer has the structure,

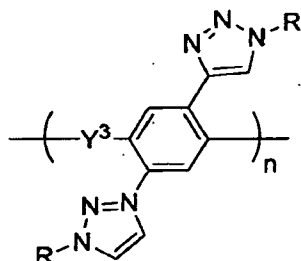

wherein

Y^3 is alkene, alkyne, aryl, heteroalkene, heteroalkyne, or heteroaryl, optionally substituted;

R is aryl or alkyl, optionally substituted; and
and n is greater than 1.

24. A method as in claim 1, wherein DMNB, when present, is present in trace quantities.

25. A method for determination of hydrazine or hydrazine derivatives, comprising:
exposing a luminescent polymer to a sample suspected of containing hydrazine or hydrazine derivatives, wherein hydrazine or the hydrazine derivative, if present, interacts with the luminescent polymer to cause an increase in the luminescence intensity of the polymer;

determining the increase in luminescence intensity of the polymer, thereby determining hydrazine or the hydrazine derivative.

26. A method as in claim 25, wherein, in the absence of hydrazine or the hydrazine derivative, the luminescent polymer comprises non-radiative pathways, and, in the presence of hydrazine or the hydrazine derivative, hydrazine or the hydrazine derivative interacts with the luminescent polymer to reduce the number of non-radiative pathways, thereby increasing the luminescence intensity of the polymer.

27. A method as in claim 25, wherein the increase in luminescence intensity further comprises a change in the wavelength of the luminescence.

28. A method as in claim 25, wherein the luminescent polymer is a poly(arylene), poly(arylenevinylene), poly(aryleneethynylene), and substituted derivatives thereof.

29. A method as in claim 25, wherein the luminescent polymer is
5 poly(aryleneethynylene).

30. A method as in claim 25, wherein the luminescent polymer has the structure,

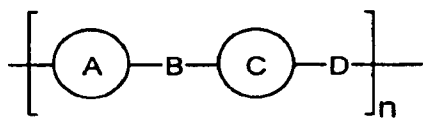

10 wherein n is at least 1, A and C are optionally substituted aromatic groups, and B and D are alkene, alkyne, heteroalkene, or heteroalkyne.

31. A method as in claim 25, wherein the luminescent polymer has the structure,

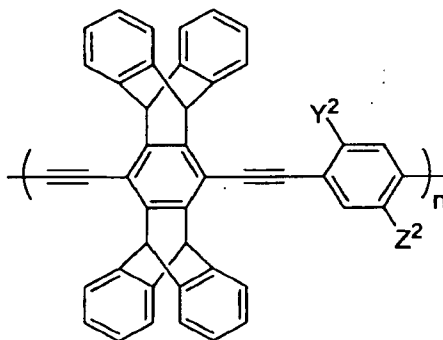

15 wherein Y² and Z² are independently alkyl, alkoxy, amino, and substituted derivatives thereof.

32. A method as in claim 31, wherein Y² and Z² are alkoxy.

33. A method as in claim 31, wherein Y² and Z² are NR¹R², wherein R¹ and R² are
20 alkyl.

34. A method as in claim 31, wherein Y² is hydrogen and Z² is NR¹R², wherein R¹ and R² are alkyl.

25 35. A method as in claim 31, wherein the luminescent polymer has the structure,

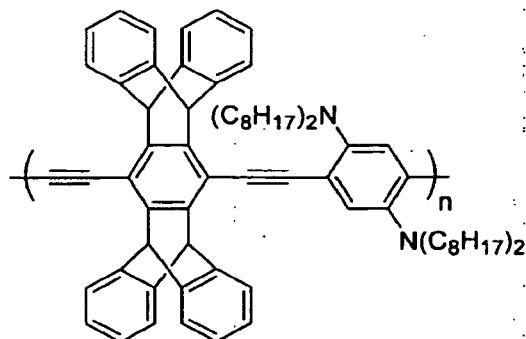

36. A method as in claim 31, wherein the luminescent polymer has the structure,

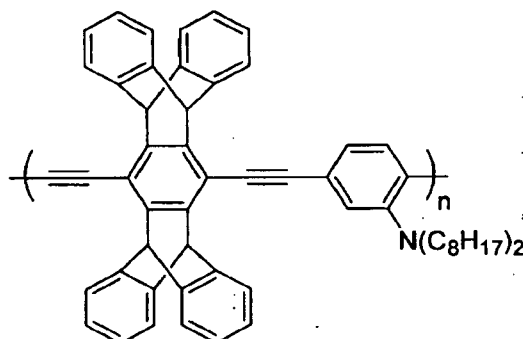

5

37. A method as in claim 25, wherein the luminescent polymer comprises a heterocycle, optionally substituted.

38. A method as in claim 25, wherein the luminescent polymer comprises a triazole group, optionally substituted.

10

39. A method as in claim 25, wherein the luminescent polymer comprises a pendant group comprising a triazole group, optionally substituted.

15

40. A method as in claim 25, wherein the luminescent polymer has the structure,

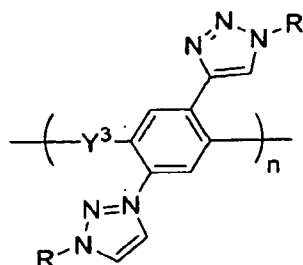

wherein

Y^3 is alkene, alkyne, aryl, heteroalkene, heteroalkyne, or heteroaryl, optionally substituted; and

R is aryl or alkyl, optionally substituted; and

and n is greater than 1.

5

41. A method as in claim 25, wherein the luminescent polymer comprises oxidized sites and the hydrazine or hydrazine derivative reduces the oxidized sites.

10

42. A method as in claim 25, wherein the luminescent polymer comprises a quenching molecule associated with the luminescent polymer and the hydrazine or hydrazine derivative reduces the quenching molecule.

43. A method as in claim 41, wherein the quenching molecule is I_2 .

15

44. A method as in claim 25, wherein, in the presence of hydrazine or the hydrazine derivative, the luminescence intensity of the polymer increases by at least 25% relative to the luminescence intensity of the polymer in the absence of hydrazine or the hydrazine derivative upon exposure to the same conditions of electromagnetic radiation.

20

45. A method as in claim 25, wherein, in the presence of hydrazine or the hydrazine derivative, the luminescence intensity of the polymer increases by at least 50% relative to the luminescence intensity of the polymer in the absence of hydrazine or the hydrazine derivative upon exposure to the same conditions of electromagnetic radiation.

25

46. A method as in claim 25, wherein, in the presence of hydrazine or the hydrazine derivative, the luminescence intensity of the polymer increases by at least 75% relative to the luminescence intensity of the polymer in the absence of hydrazine or the hydrazine derivative upon exposure to the same conditions of electromagnetic radiation.

30

47. A method as in claim 25, wherein, in the presence of hydrazine or the hydrazine derivative, the luminescence intensity of the polymer increases by at least 100% relative to the luminescence intensity of the polymer in the absence of hydrazine or the hydrazine derivative upon exposure to the same conditions of electromagnetic radiation.

48. A method as in claim 25, wherein, in the presence of hydrazine or the hydrazine derivative, the luminescence intensity of the polymer increases by at least 250% relative to the luminescence intensity of the polymer in the absence of hydrazine or the hydrazine derivative upon exposure to the same conditions of electromagnetic radiation.
49. A method as in claim 25, wherein, in the presence of hydrazine or the hydrazine derivative, the luminescence intensity of the polymer increases by at least 500% relative to the luminescence intensity of the polymer in the absence of hydrazine or the hydrazine derivative upon exposure to the same conditions of electromagnetic radiation.
50. A method as in claim 25, wherein, in the presence of hydrazine or the hydrazine derivative, the luminescence intensity of the polymer increases by at least 750% relative to the luminescence intensity of the polymer in the absence of hydrazine or the hydrazine derivative upon exposure to the same conditions of electromagnetic radiation.
51. A method as in claim 25, wherein, in the presence of hydrazine or the hydrazine derivative, the luminescence intensity of the polymer increases by at least 1000% relative to the luminescence intensity of the polymer in the absence of hydrazine or the hydrazine derivative upon exposure to the same conditions of electromagnetic radiation.
52. A method as in claim 25, wherein hydrazine or the hydrazine derivative, when present, is present in trace quantities.
53. A method for increasing the luminescence intensity of a polymer, comprising:
exposing a luminescent polymer to hydrazine or the hydrazine derivative,
wherein, in the absence of hydrazine or the hydrazine derivative, the luminescent polymer comprises non-radiative pathways, and, in the presence of hydrazine or the hydrazine derivative, hydrazine or the hydrazine derivative interacts with the luminescent polymer to reduce the number of non-radiative pathways, thereby increasing the luminescence intensity of the polymer.

54. A method as in claim 53, wherein the increase in luminescence intensity further comprises a change in the wavelength of the luminescence.

55. A method as in claim 53, wherein the luminescent polymer comprises oxidized sites and the hydrazine or hydrazine derivative reduces the oxidized sites.

56. A method as in claim 53, wherein the luminescent polymer comprises a quenching molecule associated with the luminescent polymer and the hydrazine or hydrazine derivative reduces the quenching molecule.

57. A method as in claim 48, wherein the quenching molecule is I₂.

58. A method as in claim 53, wherein, in the presence of hydrazine or the hydrazine derivative, the luminescence intensity of the polymer increases by at least 25% relative to the luminescence intensity of the polymer in the absence of hydrazine or the hydrazine derivative upon exposure to the same conditions of electromagnetic radiation.

59. A method as in claim 53, wherein, in the presence of hydrazine or the hydrazine derivative, the luminescence intensity of the polymer increases by at least 50% relative to the luminescence intensity of the polymer in the absence of hydrazine or the hydrazine derivative upon exposure to the same conditions of electromagnetic radiation.

60. A method as in claim 53, wherein, in the presence of hydrazine or the hydrazine derivative, the luminescence intensity of the polymer increases by at least 75% relative to the luminescence intensity of the polymer in the absence of hydrazine or the hydrazine derivative upon exposure to the same conditions of electromagnetic radiation.

61. A method as in claim 53, wherein, in the presence of hydrazine or the hydrazine derivative, the luminescence intensity of the polymer increases by at least 100% relative to the luminescence intensity of the polymer in the absence of hydrazine or the hydrazine derivative upon exposure to the same conditions of electromagnetic radiation.

62. A method as in claim 53, wherein, in the presence of hydrazine or the hydrazine derivative, the luminescence intensity of the polymer increases by at least 250% relative to the luminescence intensity of the polymer in the absence of hydrazine or the hydrazine derivative upon exposure to the same conditions of electromagnetic radiation.

5

63. A method as in claim 53, wherein, in the presence of hydrazine or the hydrazine derivative, the luminescence intensity of the polymer increases by at least 500% relative to the luminescence intensity of the polymer in the absence of hydrazine or the hydrazine derivative upon exposure to the same conditions of electromagnetic radiation.

10

64. A method as in claim 53, wherein, in the presence of hydrazine or the hydrazine derivative, the luminescence intensity of the polymer increases by at least 750% relative to the luminescence intensity of the polymer in the absence of hydrazine or the hydrazine derivative upon exposure to the same conditions of electromagnetic radiation.

15

65. A method as in claim 53, wherein, in the presence of hydrazine or the hydrazine derivative, the luminescence intensity of the polymer increases by at least 1000% relative to the luminescence intensity of the polymer in the absence of hydrazine or the hydrazine derivative upon exposure to the same conditions of electromagnetic radiation.

20

P1a: R = C₈H₁₇
 P1b: R = C₁₀H₂₁

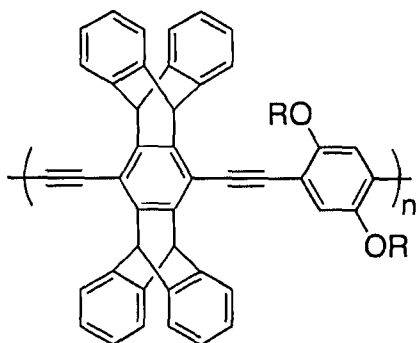

P2

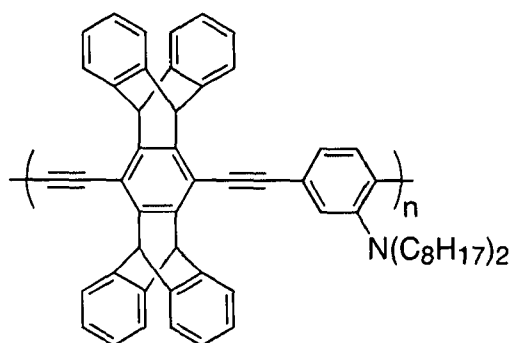

P3

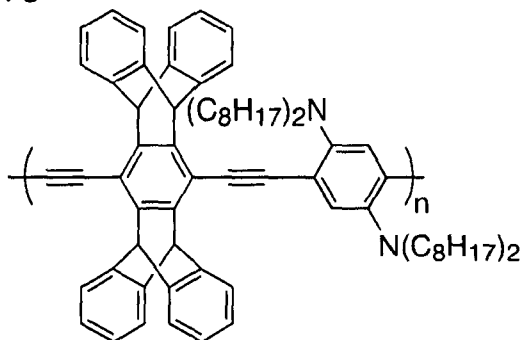

P4

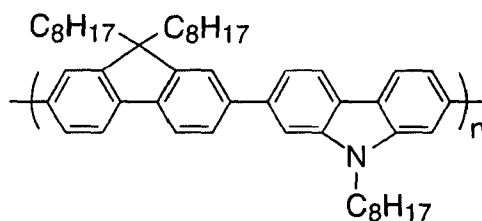

P5

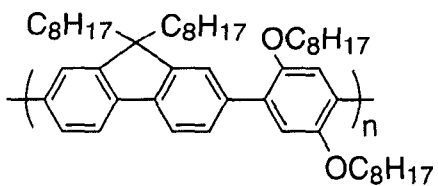

P6

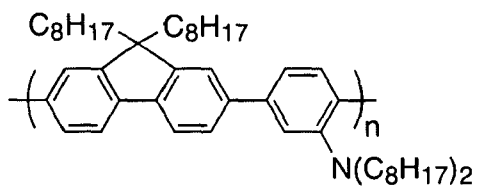

P7

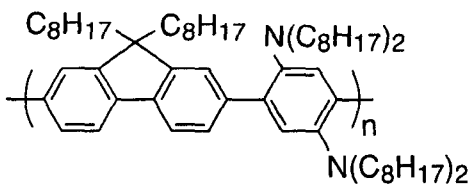

Fig. 1

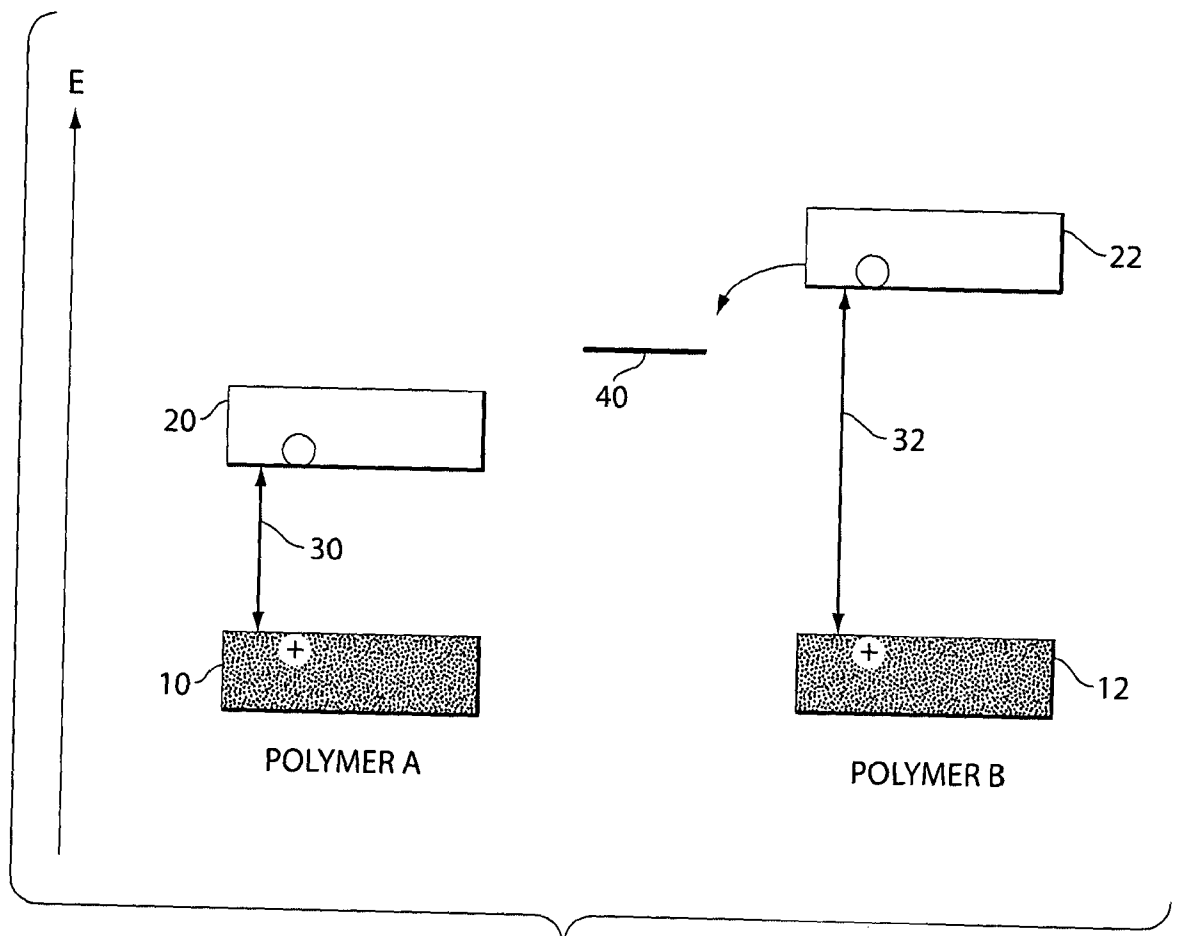

Fig. 2A

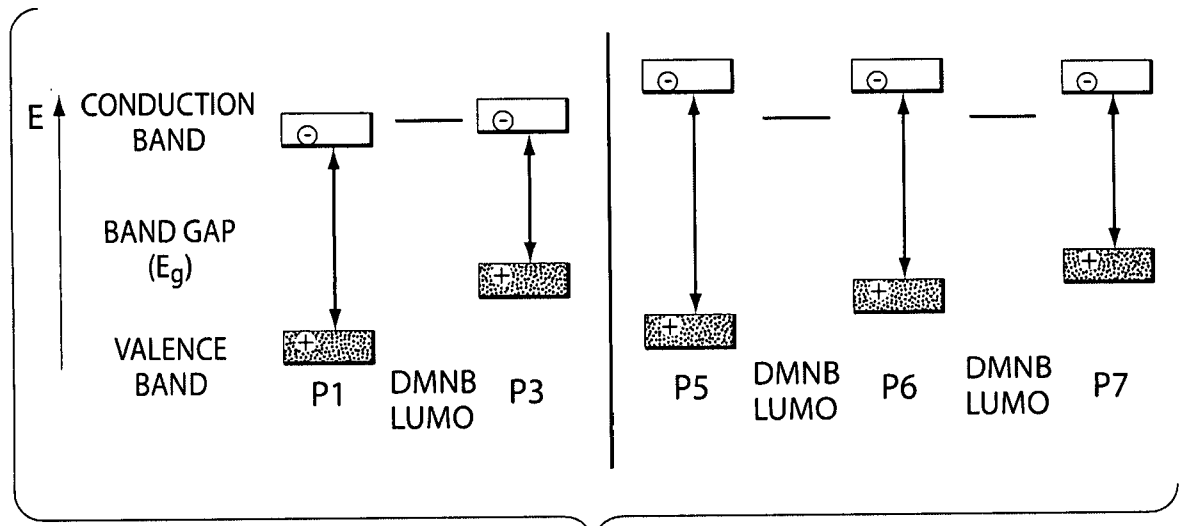

Fig. 2B

4/10

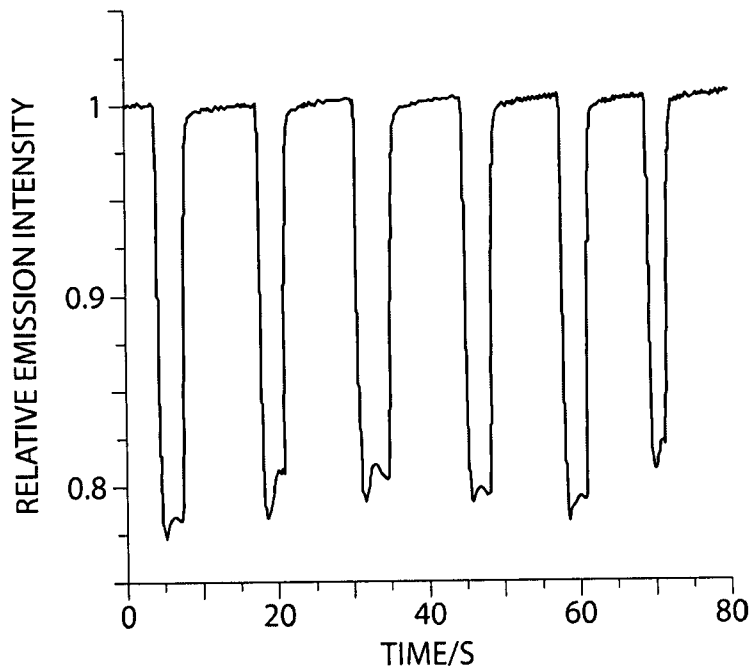

Fig. 3

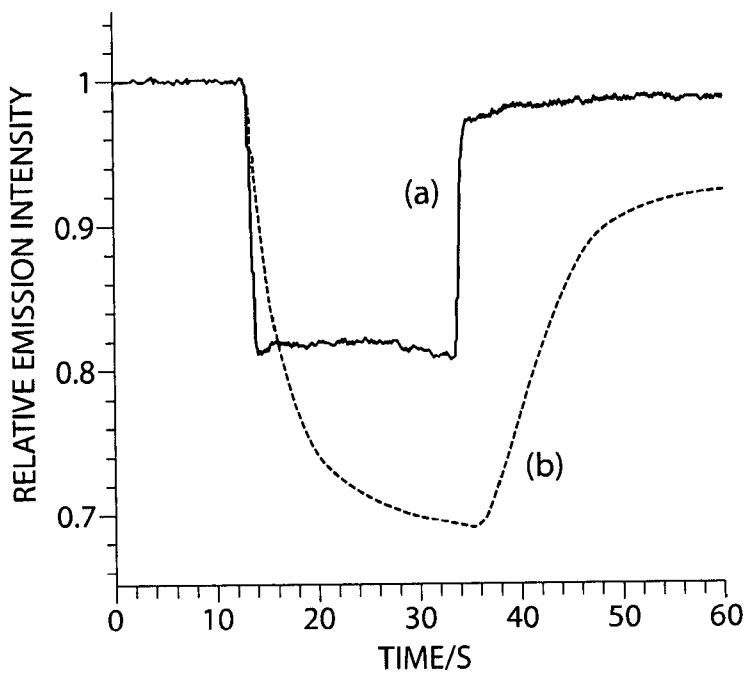

Fig. 4

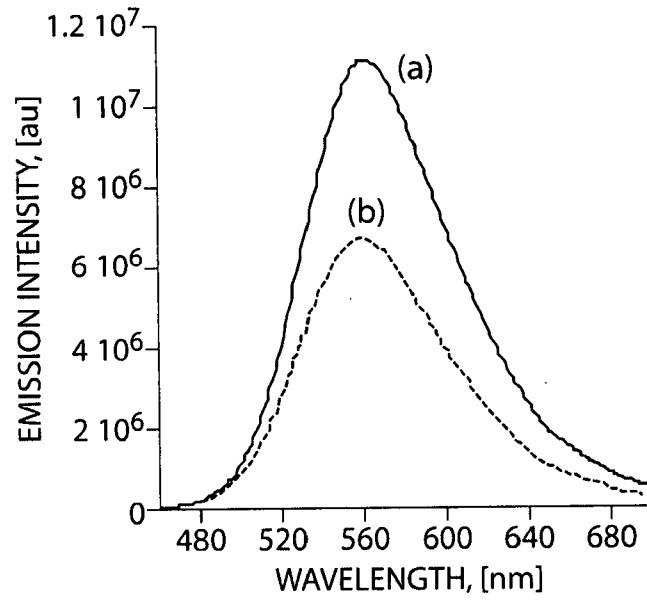

Fig. 5

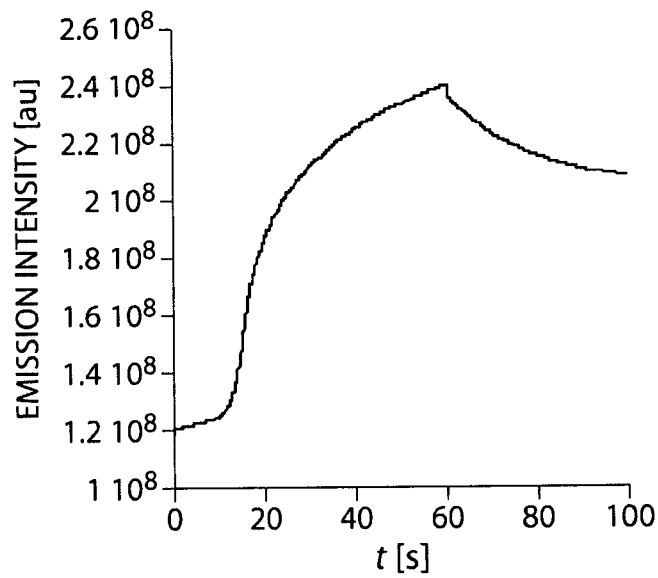

Fig. 6

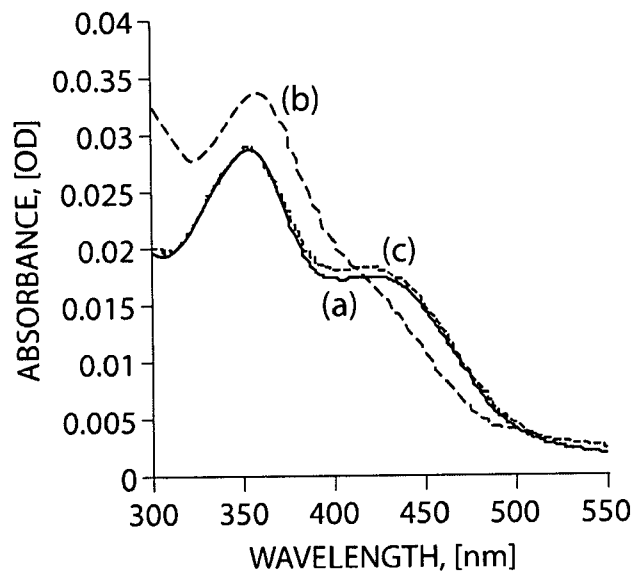

Fig. 7

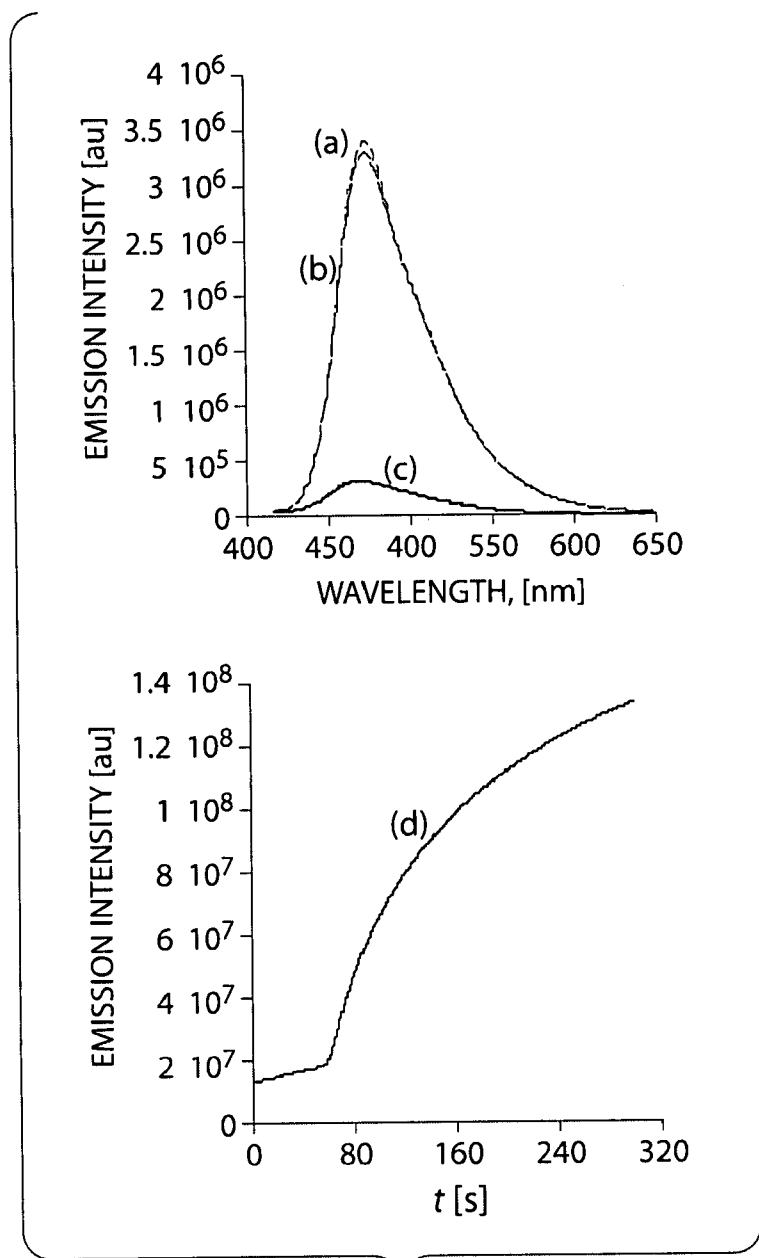

Fig. 8

8/10

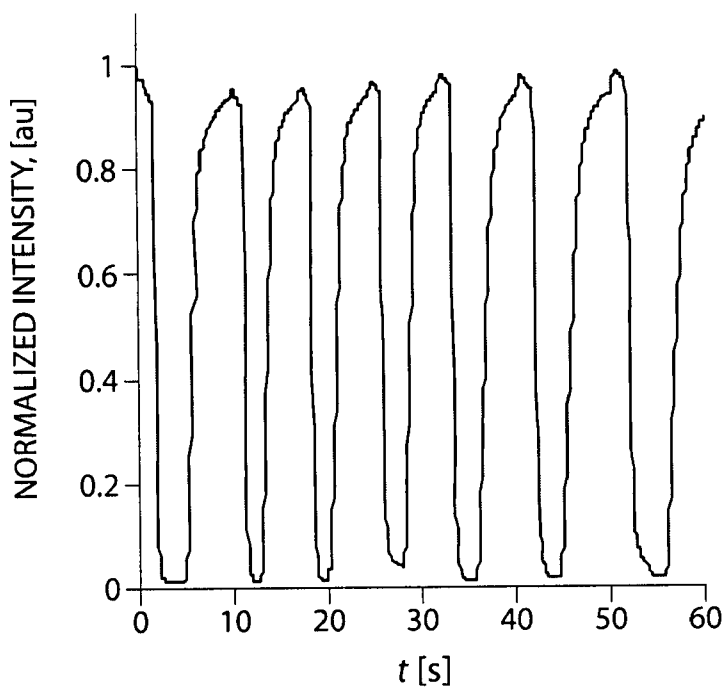

Fig. 9

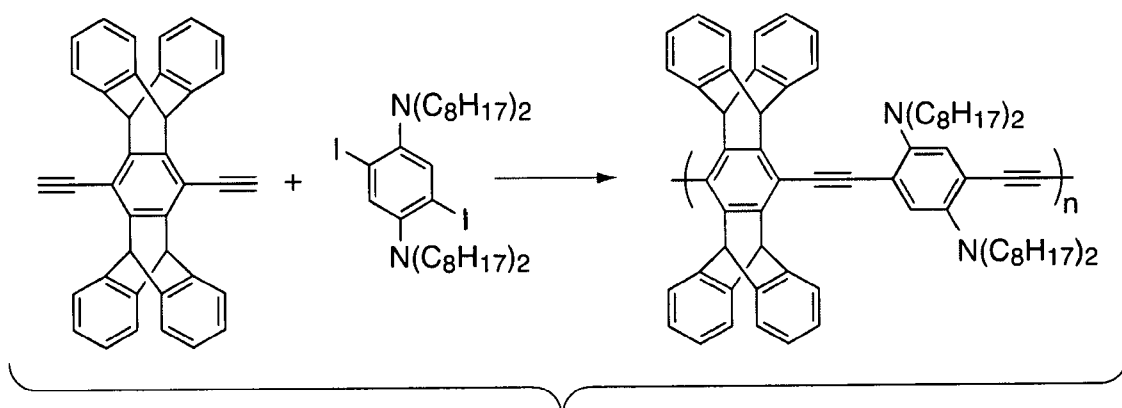

Fig. 10

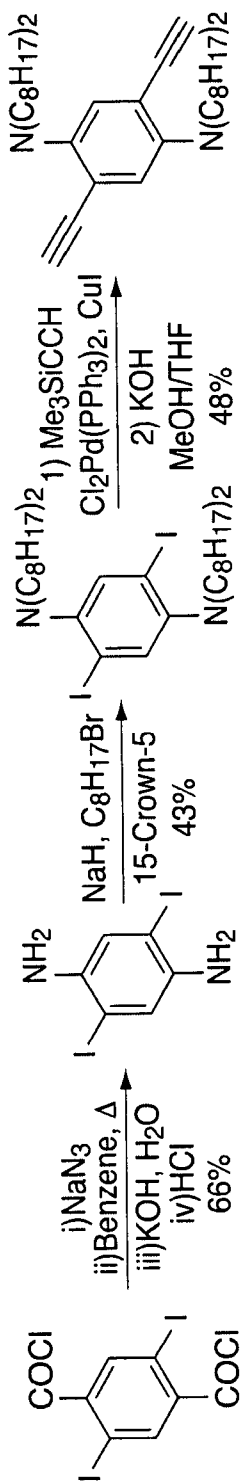

Fig. 11A

