

997,892.

W. J. BARRON.
TYPE WRITING MACHINE.
APPLICATION FILED JULY 15, 1901.

Patented July 11, 1911.

4 SHEETS-SHEET 1.

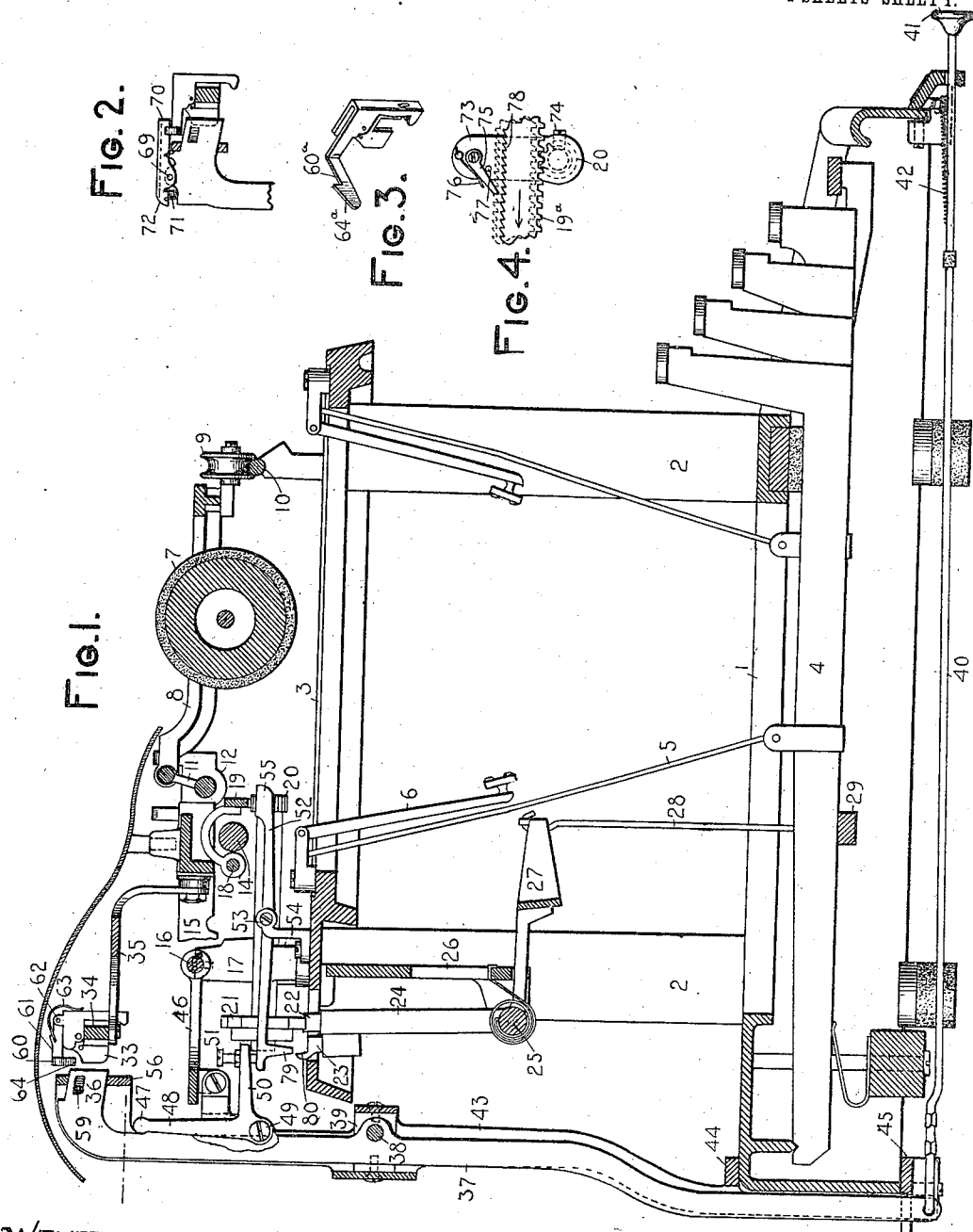

WITNESSES.

K. V. Donovan.

W. C. Schutz.

INVENTOR

Walter J. Barron

By *Jacob Felbel*

HIS ATTORNEY

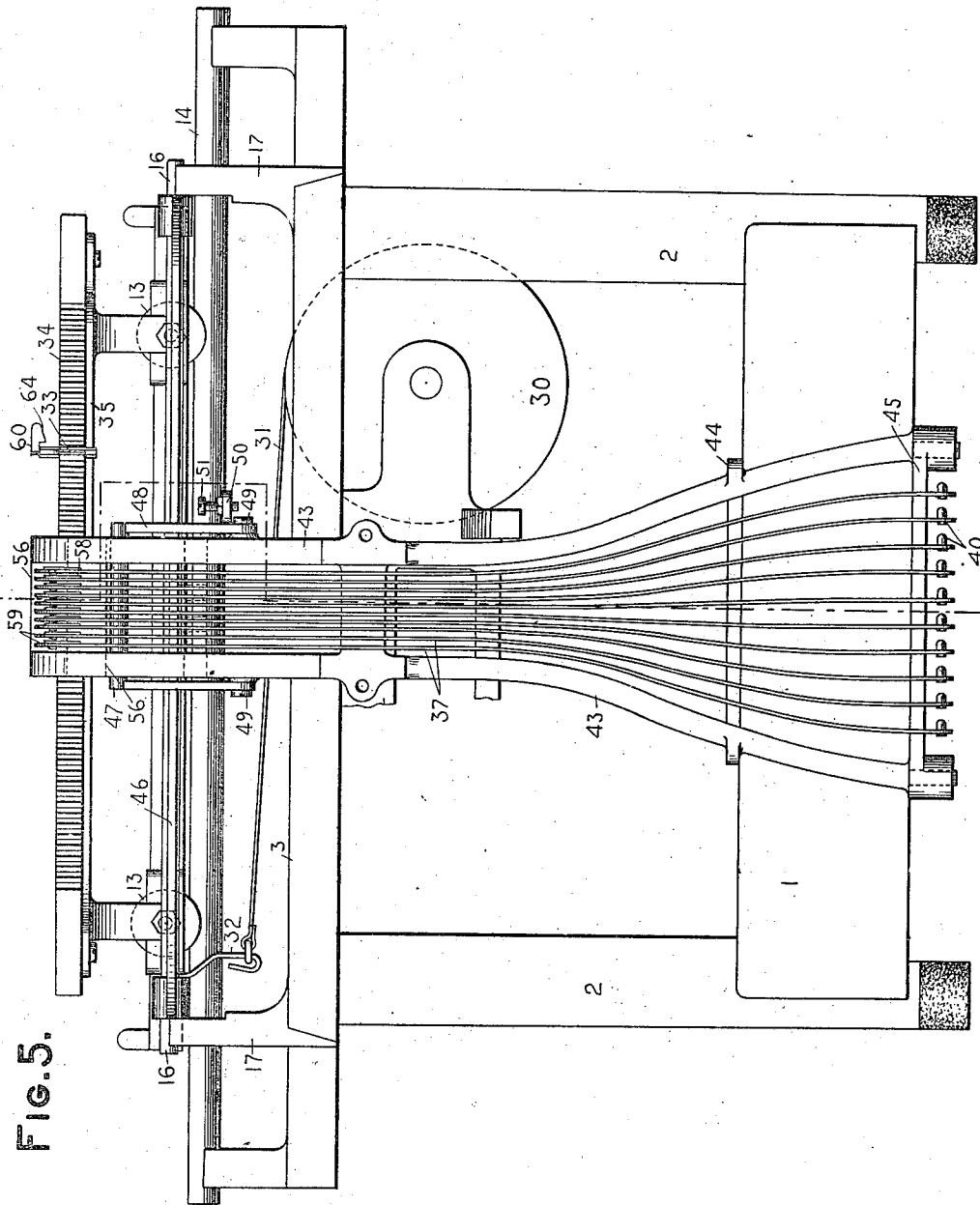

FIG. 5.

WITNESSES:

K. V. Donovan.
M. B. Schultz

INVENTOR

Walter J. Barron
by *Jacob Felber*
HIS ATTORNEY

997,892.

Patented July 11, 1911.

4 SHEETS—SHEET 3.

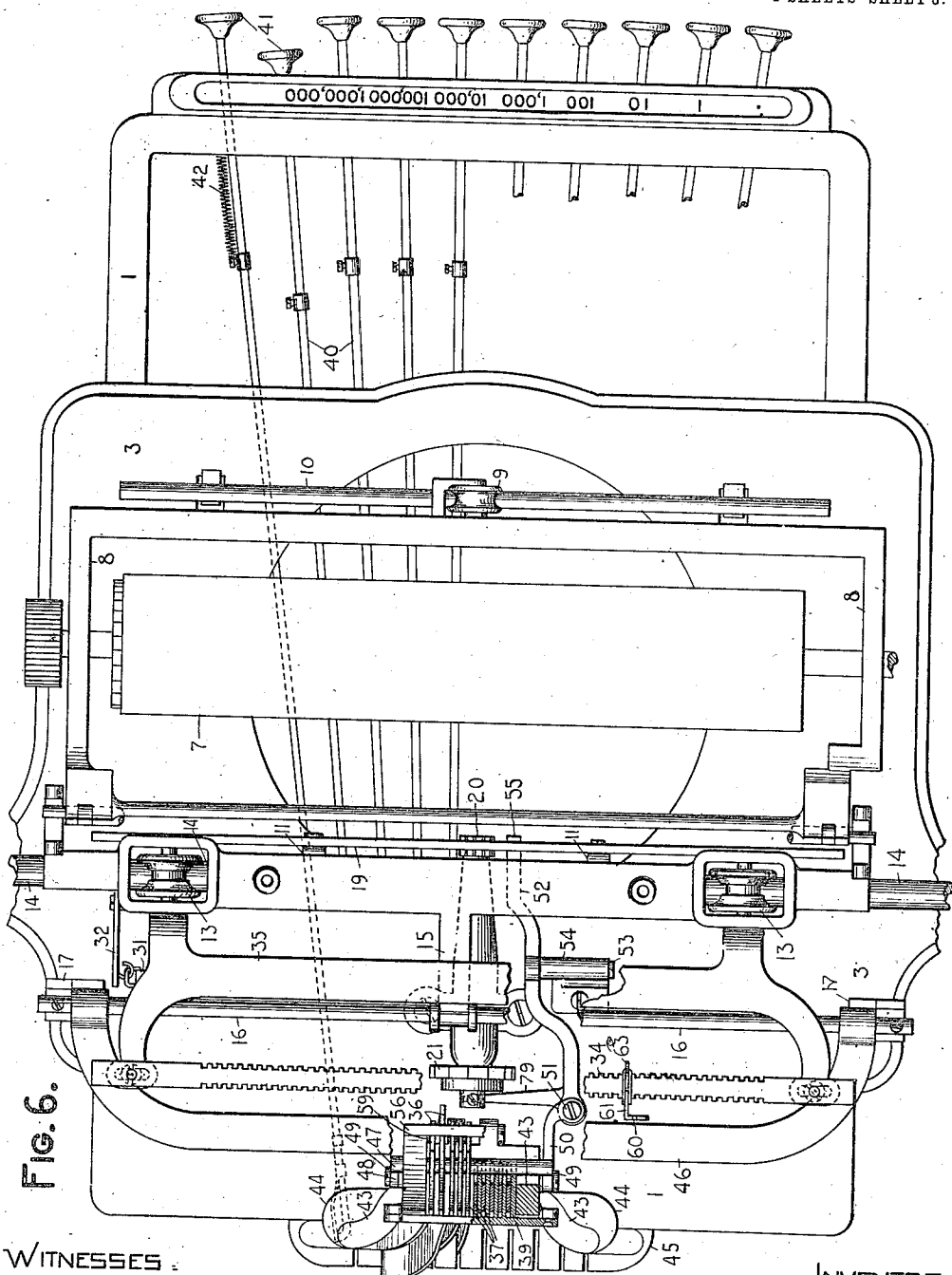

Fig. 6.

WITNESSES:
K. V. Donovan.
M. C. Schultz

INVENTOR
Walter J. Barron
 By *Jacob Feltz*
 HIS ATTORNEY

997,892.

Patented July 11, 1911.

4 SHEETS—SHEET 4.

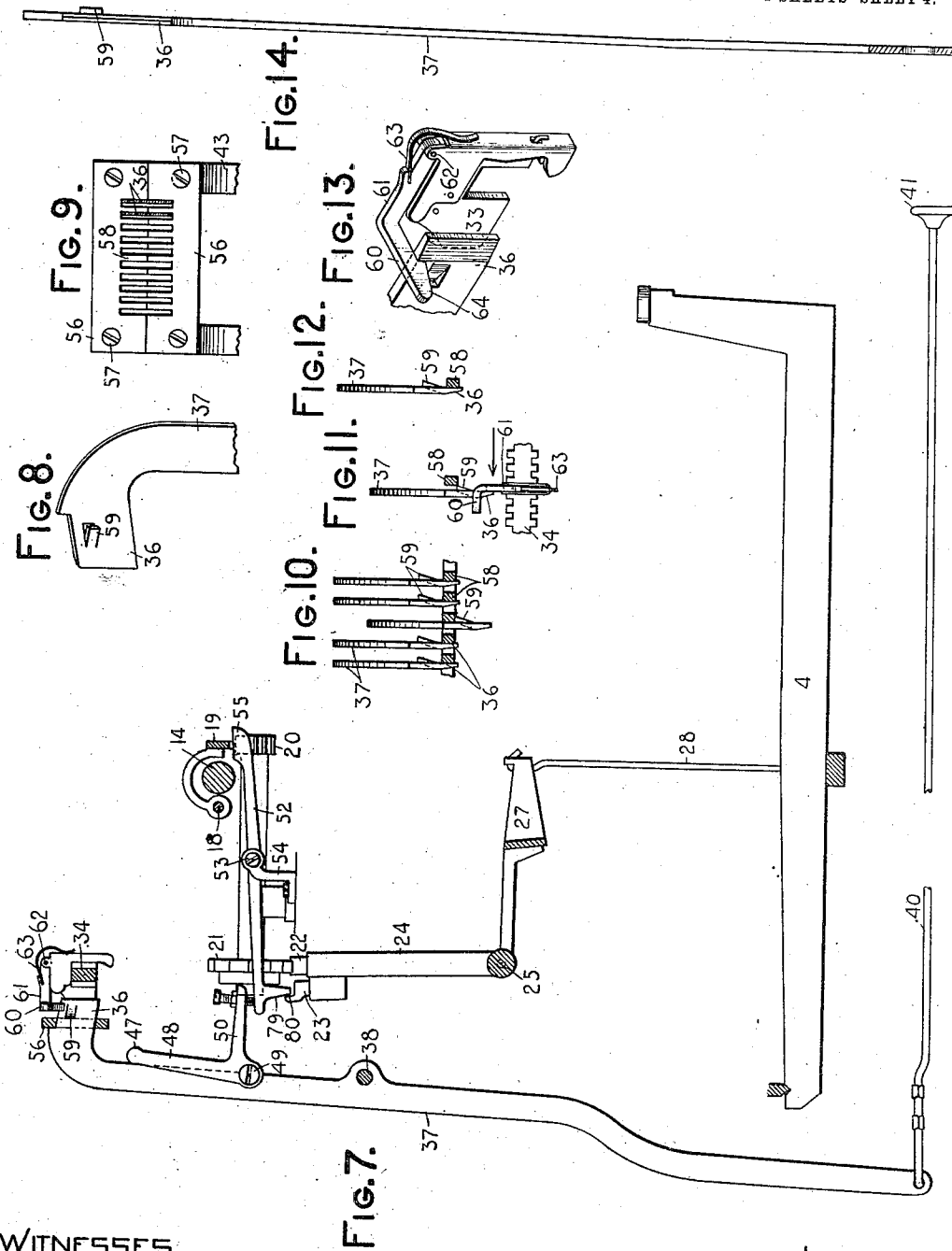

WITNESSES.

K. V. Donovan
W. C. Schultz

INVENTOR

Walter J. Barron
 by *Jacob Feld*
 HIS ATTORNEY

UNITED STATES PATENT OFFICE.

WALTER J. BARRON, OF NEW YORK, N. Y., ASSIGNOR, BY MESNE ASSIGNMENTS, TO UNION TYPEWRITER COMPANY, OF ILION, NEW YORK, A CORPORATION OF NEW YORK.

TYPE-WRITING MACHINE.

997,892.

Specification of Letters Patent. Patented July 11, 1911.

Application filed July 15, 1901. Serial No. 68,385.

To all whom it may concern:

Be it known that I, WALTER J. BARRON, citizen of the United States, and resident of the borough of Brooklyn, city of New York, in the county of Kings and State of New York, have invented certain new and useful Improvements in Type-Writing Machines, of which the following is a specification.

This invention relates to tabulating mechanisms of writing machines, and more particularly to that class of tabulators in which, at the operation of a denomination key, a stop corresponding thereto is projected, and the paper carriage is also automatically released and permitted to run down under the tension of the usual carriage spring, until arrested by said projected stop at a point where the writing of a number having the denomination of the operated key may be begun.

In using machines of this class, operators sometimes fail to hold the denomination key in working position until the completion of the run of the carriage, particularly when there is a long jump or gap between columns, and in consequence the carriage is prematurely reengaged to its letter-feeding devices and arrested thereby, so that the succeeding number is written out of column.

One object of the present invention is to produce a machine in which a single stroke of the selected key insures that the carriage shall run to the next column and be arrested at the exact point for writing a number of the denomination denoted by said key, without any attention on the part of the operator beyond merely pushing the key to the working position, so that while the carriage is running he is at liberty to move his hands into position to begin promptly the writing of the number, whereby he is relieved of care and liability to mistakes, and is also enabled to execute the work more expeditiously.

Another object of the invention is to cause both the type-operating keys and the spacing key to be locked during the jump of the carriage, so as to prevent accidental operation of the carriage feeding dogs by any of said keys, which would have the effect of causing the carriage to be stopped in an erroneous position; and also so as to prevent printing during said jump movement of the carriage.

Other objects will appear hereinafter.

My invention consists in certain features of construction, combinations of devices and arrangements of parts, all as will be fully hereinafter set forth and particularly pointed out in the concluding claims.

In the accompanying drawings:—Figure 1 is a vertical section taken longitudinally of a Remington No. 6 typewriting machine and showing my improvements applied thereto, all of the parts being illustrated in normal position. Fig. 2 is a fragmentary side elevation, partly in section, of a modified construction for preventing rebound of the carriage when tabulating. Fig. 3 is a perspective view of the column stop shown at Fig. 2. Fig. 4 is a fragmentary view of another means for preventing rebound of the carriage. Fig. 5 is a rear view and Fig. 6 a plan of the machine shown at Fig. 1. Fig. 7 is a skeleton view similar to Fig. 1, but showing a denomination-stop locked in working position, the carriage locked thereby against rebound, and the type-keys also locked in normal position. Fig. 8 is an enlarged view of the upper portion of a denomination-stop lever. Fig. 9 is a front elevation of a guide comb for the denomination stops, two of the latter being shown in cross-section. Fig. 10 is a sectional plan showing a portion of the denomination stops, whereof one is shown projected and caught by an adjacent tooth of the guide comb, which latter is drawn in horizontal section. Fig. 11 is a plan showing a column stop, a fragment of its supporting rack, and a denomination stop engaged by the column stop and released thereby from its detaining comb tooth and also showing the denomination stop as caught by a column stop hook, whereby rebound of the carriage is prevented. Fig. 12 is a view similar to Fig. 10, but showing only a single denomination stop and its associated detent and comb tooth. Fig. 13 is an enlarged perspective fragmentary view of the devices illustrated at Fig. 11, the column-stop rack being omitted. Fig. 14 is an enlarged front edge view of the upper portion of a denomination-stop lever.

In the several views portions are omitted or broken away to disclose the invention more clearly, and similar parts are designated by similar numerals of reference.

The writing machine comprises a rectangular base 1, corner posts 2 erected thereon, a top plate 3 surmounting the posts, key levers 4 fulcrumed in the base, links 5 connecting said key levers to type bars 6, a platen 7, arranged over the types, a platen frame 8 having a front roll 9 running upon a track 10 and hinged in rear to a vibrating frame 11, which is hinged to a carriage 12, 10 guided by rolls 13 upon a rail 14, and also provided with a rearwardly directed guiding arm 15, which forks a rail 16, the latter being secured in opposite standards 17 provided upon the top plate. Upon the carriage 15 is hinged at 18 a frame which carries a rack 19, meshing with an underlying pinion 20, the latter being connected to an escapement wheel 21, which is controlled by a feeding dog 22 and a detent dog 23, both 20 carried upon the upper end of a dog rocker 24 pivoted at 25 in a bracket 26 depending from the top plate, and having forwardly extending arms 27, which support, by means of hooks 28, a universal bar 29 that extends 25 across the machine beneath the key levers. The advance movements of the carriage are effected by a propelling spring carried in a barrel 30, which is connected by a strap 31 to a hook 32 depending from the carriage.

30 Column stops 33 of the usual general construction are disposed along a rack 34, which extends in the direction of the run of the paper carriage, and is secured to a frame 35 mounted thereon.

35 Denomination stops 36, arranged at letter space intervals, are formed upon the upper ends of vertical levers 37 of the first order, which are fulcrumed upon a transverse rod 38 and separated by plates 39, and at their 40 lower ends are provided with horizontal push rods 40, bearing keys 41 and having returning springs 42. The said fulcrum rod 38 is supported in a frame 43, which is clamped upon the base by cleats or flanges 45 44 and 45, and is at its upper end supported by a yoke 46, which engages the carriage rail 16. The levers 37 fan out at their lower ends, and the key rods 40 diverge forwardly.

45 A carriage-releasing bar 47, arranged transversely in front of the upper portions of the stop levers 37, is carried by a pair of vertical rocker arms 48, which are pivoted at their lower ends on shouldered 50 s 49. Upon the left-hand rocker arm 55 48 is formed a forwardly projecting arm 50 carrying an adjustable screw 51 adapted to depress the rear end of a forwardly extending release lever 52, which is pivoted between its ends at 53 upon a bracket 54, and 60 is provided at its forward end with a head 55 adapted to lift the carriage-feed rack 19 out of mesh with its pinion 20.

The denomination stops 36 project forwardly from the levers, and work in a ver-

tical guide comb 56, which preferably is 65 formed by a pair of slotted plates placed edge to edge and fastened upon the frame 43 by screws 57 (see Fig. 9). In each stop 60 is cut or stamped a rearwardly directed locking tooth 59, which projects to the right, 70 and normally stands just behind the comb 56. Before assemblage, the upper portion of each of the stop levers 37 is bowed 75 slightly toward the right, as illustrated at Fig. 9, so that it is necessary to spring them 75 slightly toward the left when introducing the stops between the comb teeth, said teeth being in register with the spacing plates 39 at the lever hubs. By this means the levers are 80 given a natural or inherent spring tension toward the right, whereby, upon their forward movement, the projecting teeth 59 thereon are forced beyond the comb teeth 85 58 and then caused to snap or latch over the front faces thereof, as shown at Fig. 10, thus locking the stops against return movement.

In operation, after setting the column stops at the desired points along the rack 34, a key 41 of the selected denomination is 90 pushed rearwardly, and by means of rod 40 it swings its lever 37 upon the axis 38, thus moving the stop 36 carried at the upper end of said lever forwardly into the path of the 95 column stop 33. The stroke of the lever and key is limited by a shoulder which is formed upon the top of the lever and contacts with the rear face of the comb, while at the same time, owing to the lateral tension of the 100 upper arm of the lever 37, the tooth 59 thereon is caused to snap into engagement with its associated detent or comb tooth, 58, as illustrated at Fig. 10, thus locking the denomination stop in working position. The release 105 bar 47 is also borne forwardly by said projected stop lever 37, and by means of the arm 50 and the screw 51 depresses the rear end of lever 52, the forward end of which lifts the carriage feed rack 19 clear of the 110 pinion 20, whereby the carriage is freed from the control of its escapement devices, and is rapidly advanced by the driving spring in the barrel 30 and a strap 31, whereupon the succeeding column stop 33 115 abuts against the projected denomination stop 36, thus arresting the carriage in position to begin the writing of a number of the selected denomination.

By the impact of the column stop, the denomination stop is moved from the figure 10 120 to the figure 11 position, the force of the carriage-propelling spring being sufficient to overcome the inherent spring tension of the lever 37, so that the denomination stop, being thus disengaged from its detent, is free 125 to move backward under the tension of the returning spring 42. The pull of said spring is sufficient to overcome the friction

between the column stop and the denomination stop, as well as that between the denomination stop and the combtooth, and to draw the denomination stop back out of the path of the column stop, whereas the retraction of the carriage-releasing devices and the reengagement of the carriage-feed rack 19 with the pinion 20, is caused by the usual rack spring (not shown).

10 The carriage sometimes rebounds upon striking the denomination stop, and would be liable, if permitted to become reengaged to its escapement devices during such rebound, to settle at an erroneous position.

15 To avoid this I provide means for preventing such rebound; said means consisting preferably of an angular latch pivoted upon each column stop and consisting of a hooked portion 60 which extends parallel with the run of the carriage, and a base portion 61 which is parallel with the column stop and is pivoted at 62 to the upper portion of the latter a spring 63 being inserted in the arm 61 and curving over the corner of the column stop and bearing against the front vertical face thereof. When, during the run of the carriage, the beveled edge 64 of the latch strikes the projected denomination stop, it is cammed up over said stop, and under the tension of the spring 63 snaps down over the same, as illustrated in Fig. 13, thus effectually preventing rebound of the carriage. This locking of the carriage does not, however affect the above narrated releasing action of the column stop upon the denomination stop, and hence the latter returns immediately to normal position under the tension of the spring 42. Upon such return, the latch 60 of course no longer acts to prevent reverse movement of the carriage, so that the latter may then be moved freely in either direction if desired. It will be perceived that the denomination stop and the latch 60 cooperate only momentarily, but this is sufficient to check the rebound of the carriage or at least limit such rebound to a distance less than a letter space which practically is the same thing as preventing absolute rebound of the carriage.

50 In the form shown at Figs. 2 and 3, the angular latch arm 60^a is formed integral with a portion of the column stop, instead of being pivoted thereon, and its tooth projects upwardly; while upon the top of each denomination-stop lever is pivoted at 69 a forwardly extending pawl 70, which is adapted to be cammed upwardly by the beveled face 64^a on the column stop latch, and then to snap down into locking position, under the force of a compression spring 71, which is inserted between the top of the stop lever and a nib 72 formed upon the pawl in rear of its pivot 69. Thus said pawl 70 momentarily prevents rebound of the

carriage, and is then withdrawn together 65 with its denomination stop, by the action of the spring 42.

In the form shown at Fig. 4, a standard 73 is secured by a set screw 74 upon the bracket in which the carriage pinion 20 is 70 mounted, and carries at its top portion a downwardly directed pawl 75, pressed by a spring 76 against a stop pin 77. The point of this pawl normally stands just above a series of teeth 78 formed along the upper 75 edge of the carriage rack bar 19^a—the direction of said teeth being such that they may cooperate with said pawl to prevent backward movement of the carriage, while permitting advance movement thereof. When 80 the carriage-release lever 52 is operated, as above described, and the rack 19 is thereby lifted to the dotted line position at Fig. 4, the said teeth 78 are caused to mesh with the pawl 75, so that during the jump of the 85 carriage said pawl rides freely over the teeth; but when the carriage is arrested by the engagement of its stops the pawl and rack cooperate to prevent rebound of the carriage. Upon the return of the projected de- 90 nomination stop to normal position, together with the carriage-releasing devices, the rack 19^a drops again and frees the teeth 78 from the control of the pawl 75, so that the carriage may be moved freely to the right when 95 desired.

The construction shown in Fig. 4 has been made the subject-matter of a divisional application filed by me Nov. 14th, 1907, Serial No. 402,141, the construction shown 100 in Fig. 4 being specifically claimed in said divisional application; the anti-rebound mechanism being broadly claimed herein.

Upon the under side of the said carriage-release lever 52 at its rear end is formed a 105 tumbler or lug 79, which is adapted on the down movement of the lever to drop in front of a stop lug 80 projecting upwardly from the rigid carriage-detent dog 23, so that when a denomination key 41 is operated, not 110 only is its connected stop set and locked in working position, together with the carriage-releasing devices but also by the engagement of said tumbler with said lug the operation of the dog-rocker 24 is prevented, 115 so that should the operator either accidentally or prematurely strike either a type key or the spacing key, it would fail to operate, since the dog rocker is thereby prevented from moving during the transit of the carriage or as long as the denomination stop remains locked in working position. By this means I insure that the carriage shall be stopped at the exact position determined at the operation of the denomination key, so 125 that liability of mistakes is avoided.

It will be seen that the denomination stops considered as a set have an immovable or

fixed position relatively to the longitudinal movements of the carriage; that is to say the said set is arranged constantly in a similar position, thus enabling narrow columns 5 to be written in close order upon the page, if desired; that a spring latch moves with each denomination stop; that means engage with said latch for holding the stop in its projected position; that a carriage release 10 device is also detained automatically in working position by the denomination stop latches; that with a series of latches is combined means engaging with each latch for detaining the carriage releasing device in 15 operative position, said latches each having a part that is movable into the path of a part upon the carriage so as to enable the latter to bear directly upon said latches and move them clear of said detaining means, 20 each latch being directly releasable by the contact of the carriage therewith; and that the carriage releasing devices are operable by all of said latches. It will also be seen that each denomination stop is provided 25 with a tooth which projects laterally therefrom; that each of said stops when projected is moved laterally a distance less than a letter space in projected position; that the means for locking said stops in their 30 projected position are released by the carriage at the moment of the impact of the projected stop by a column stop; that is to say, that the contact of the column stop with the denomination stop and the release of 35 the carriage occur practically at the same instant and without the necessity of making a prolonged additional movement of the carriage after the contact of its stop with the projected denomination stop, the stop releasing movement of the carriage being con- 40 siderably less than a letter space and being so small as to be negligible, and there being a simultaneous lateral movement of both the column and the projected denomination stop for this slight distance; and that the latches 45 comprising the spring levers 37 and the teeth 59 thereon all control the carriage releasing mechanism so as to hold it in working position, which function obviously may be per- 50 formed by them if desired, independently of the column stops and denomination stops. It will be further perceived that the means for detaining the said denomination stop and the means for preventing rebound of the 55 carriage are both released by the latter upon the arrest thereof by the cooperation of the column stop with the denomination stop; that said latch (61 or 70) for preventing rebound is adapted to engage a stop detaining device (36 or 60^a) and that upon the return 60 of the denomination stop to the normal position the latch becomes disconnected from the detaining device; that a column stop and a denomination stop thus cooperate to prevent rebound of the carriage as well as to 65 enable the denomination stop to return to normal position; that the means for preventing rebound of the carriage are inoperative when the denomination stops are all in normal position; that the column stop is tem- 70 porarily locked to the denomination stop; that a latch or detent is carried by one of the cooperating stops and adapted to engage the other of said stops; that a set of column stops upon the carriage cooperates with a set 75 of denomination stops upon the machine frame; that a set of devices is carried by one of said sets of stops and adapted to cooperate with the other set of stops for checking the rebound of the carriage; that the den- 80 omination stops are movable in the path of the column stops and the latches carried upon the latter; and that each of said latches engages a part which is automatically moved out of engagement therewith upon the re- 85 turn of the carriage releasing device to normal position. It will also be observed that the carriage feeding devices are controlled by a series of type operating keys, and that the movement of the latter is prevented after 90 the carriage is released and before it is arrested by the contact of the stops 33 and 36, or while the carriage release device is locked in working position by the detent 59; that the key locking device, the carriage releasing 95 device and the denomination stop, are simultaneously moved to working position and severally held there by the tooth 59; that said key locking device is set by the carriage releasing bar 47 arranged in the path of the 100 denomination stop levers 37; and that said releasing bar operates the releasing lever 52 which carries the tumbler 79 which intercepts the movement of the dog rocker. It will likewise be seen that the means for pre- 105 venting a letter space rebound of the carriage are actuated by the impact of the carriage; that they are rendered effective by the travel of the carriage and that a spring pressed catch which prevents the rebound 110 of the carriage is actuated or is moved against its spring tension by the impact of the carriage.

Certain features of construction herein shown have been invented by Louis P. Diss 115 and William A. Schmidt and are claimed in an application filed by them contemporaneously herewith.

I do not claim the following subject-matter:—In typewriting machines, the combina- 120 tion with the machine frame and with paper support, of spacing mechanism comprising a column stop member mounted on one of said parts, a dogging member upon the other of said parts normally out of line with said 125 stop member, means for moving one of said members and a device for locking said movable member in line with the other of said

members, said locking devices arranged to be released by the contact of said members.

What I claim as new and desire to secure by Letters Patent, is:—

5 1. In a typewriting and tabulating mechanism, the combination with a carriage and a carriage-feeding mechanism, of a column stop adjustable along the carriage, a set of denomination stops arranged upon the
10 framework, a frame or support for said set of stops, said frame or support being immovable or having a fixed position relatively to the longitudinal movements of the carriage, means for projecting said stops into
15 the path of said column stop, and means for detaining any of said denomination stops in its projected position, said detaining means being releasable by the carriage.

2. In a typewriting and tabulating mechanism, the combination with a carriage and a carriage-feeding mechanism of a stop upon the framework, a carriage stop, means for projecting one of said stops to a position
20 where it may engage the other, a latch moving with said projected stop, and means engaging with the said latch so as to hold the stop in its projected position, said latch being
25 releasable by the carriage.

3. In a typewriting and tabulating mechanism, the combination with a carriage and a carriage-feeding mechanism, of a column stop adjustable along the carriage, a set of denomination stops arranged upon the framework, said set being immovable or having
30 a fixed position relatively to the longitudinal movements of the carriage, a set of keys arranged at the front portion of the machine and connected to said denomination stops, and means for detaining said stops
35 and keys in working position, said detaining means being releasable by the carriage.

4. In a typewriting and tabulating mechanism, the combination with a power-driven carriage and carriage-feeding devices, of a carriage-releasing device, a series of latches, and means engageable with each latch for
40 detaining said carriage releasing device in operative position, said latches each having a part which is movable into the path of a carriage part so as to enable the latter to
45 bear directly against said latches and move them clear of said detaining means.

5. In a typewriting and tabulating mechanism, the combination with a carriage and a carriage-feeding mechanism of a stop, a set of independently movable denomination stops cooperating with said stop, and a set of spring latches one for each denomination
50 stop, each latch being adapted to detain its stop in working position and being directly releasable by the contact of a carriage part therewith.

6. In a typewriting and tabulating mechanism, the combination with a power-driven

carriage and a carriage-feeding mechanism, 65 of a column stop mounted upon the carriage, a series of independently movable denomination stops mounted upon the framework and each provided with a spring latch, means for engaging said latches when the
70 stops are projected, so as to detain the latter in working position, said latches being releasable by the carriage, a series of keys mounted upon the framework and connected to said denomination stops; and carriage-
75 releasing devices operated by said keys and controllable by all of said latches.

7. In a typewriting and tabulating mechanism, the combination with a power-driven carriage and carriage-feeding devices, of a carriage stop, a set of denomination stops, a carriage-releasing device, a set of keys for
80 said denomination stops, and a set of latches for locking in working position both said denomination stops and said carriage-releasing device, said latches being set by said
85 keys and released by said carriage.

8. In a typewriting and tabulating mechanism, the combination with a carriage and carriage-feeding devices, of a stop upon the carriage, a set of denomination stops, mounted
90 upon the framework and each provided with a tooth projecting laterally therefrom, means for moving said stops laterally a distance less than a letter space, stop-projecting
95 means and fixed devices cooperating with said teeth for detaining the stops in their projected positions, said stops being releasable by the impact or pressure of the carriage stop.

9. In a typewriting and tabulating mechanism, the combination with a carriage and carriage-feeding devices, of a stop upon the carriage, a set of independently movable laterally-springing levers mounted upon the
100 framework each lever carrying a tooth projecting laterally therefrom, stops carried upon said levers and projected thereby into the path of the carriage stops, and also sprung thereby in a lateral direction, and a
105 guide comb for said levers, the said projecting teeth being adapted to engage the teeth of said guide comb so as to hold said stops in working position.

10. In a typewriting and tabulating mechanism, the combination with a carriage and carriage-feeding devices of a carriage stop, a cooperating stop, a tooth projecting laterally from one of said stops, means for projecting
110 the tooth carrying stop, means for causing the tooth to spring laterally when the stop is projected, and means engaging the said tooth for defining said stop in its projected position.

11. In a typewriting and tabulating mechanism, the combination with a carriage and carriage-feeding devices, of a carriage stop, a cooperating stop, a tooth projecting
125

laterally from one of said stops, means for projecting the toothed stop, means for causing the tooth to move laterally when the stop is projected, and means engaging the said tooth for detaining said stop in its projected position, said detained stop being released by the pressure of the other of said stops at the arrest of the carriage.

12. In a typewriting and tabulating mechanism, the combination with a carriage and carriage-feeding devices, of a stop, a series of independently movable denomination stops; means for projecting the latter, and means for locking said stops in their projected positions, said locking means being released by the carriage at the moment of the impact of the projected stop, by the first mentioned stop.

13. In a typewriting and tabulating mechanism, the combination with a carriage and carriage-feeding devices, of a stop, a series of independently movable denomination stops, means for projecting the latter, and means for locking said stops in their projected positions, said locking means being released by the carriage at the impact of the projected stop by the first mentioned stop and the stop-moving or stop-releasing movement of the carriage being less than a letter-space movement thereof.

14. In a typewriting and tabulating mechanism, the combination with a carriage and carriage-feeding devices, of a stop, a cooperating stop, means for projecting one of said stops, means for releasing the carriage, and means for detaining in working position both the projected stop and the carriage-releasing means, said detaining means being automatically released by the carriage at the moment of the impact of the projected stop and its cooperating stop.

15. In a typewriting and tabulating mechanism, the combination with a carriage and carriage-feeding devices, of a stop, a cooperating stop, means for projecting one of said stops, means for releasing the carriage, and means for detaining in working position both the projected stop and the carriage-releasing means, said detaining means being automatically released by the carriage at the moment of the impact of the projected stop and its cooperating stop, by a simultaneous lateral movement of said stops for a distance of less than a letter space.

16. In a typewriting and tabulating mechanism, the combination with a carriage and carriage feeding devices, of a stop, a cooperating stop, a denomination-determining mechanism, a series of latches operated by said denomination-determining mechanism, and a carriage-releasing device controlled by said latches, the latter being released by the contact of the projected stop with the cooperating stop.

17. In a typewriting and tabulating mechanism, the combination of a power-driven carriage, a letter spacing mechanism therefor, a set of column stops, and a set of denominational stops, means for causing engagement between one of said column stops and one of said denominational stops, means for releasing the carriage from its letter spacing mechanism, and means for limiting the rebound of the carriage to a distance less than a letter space distance when the said column stop and the said denominational stop come into cooperative engagement.

18. In a typewriting and tabulating mechanism, the combination of a power-driven carriage, a letter spacing mechanism therefor, a set of column stops and a set of denominational stops, means for projecting any one of said denominational stops into the path of movement of one of said column stops, means for locking said denominational stop in its projected position, means for releasing the paper carriage to permit its advancement and to be arrested subsequently by the contact of said column stop with said projected and locked denominational stop, and the said denominational stop being unlocked by the impact therewith of the said column stop, and means for preventing the rebound of the paper carriage a distance equal to that of a letter space at the time of said impact between the column stop and the denominational stop.

19. In a typewriting and tabulating mechanism, the combination with a power-driven carriage and carriage-feeding devices, of cooperating stops one arranged upon the carriage and the other upon the framework, means for projecting one of said stops, means releasable by the impact of the carriage for detaining said stop in its projected position, and means for preventing rebound of the carriage.

20. In a typewriting and tabulating mechanism, the combination with a power-driven carriage and carriage-feeding devices of cooperating stops normally out of cooperative relation, one arranged upon the carriage and the other upon the framework, means for projecting one of said stops to bring them into cooperative relation, and means for preventing rebound of the carriage without limiting the speed of its run in the direction of its feed.

21. In a typewriting and tabulating mechanism, the combination with a power-driven carriage and carriage-feeding devices of cooperating stops, one arranged upon the carriage and the other upon the framework, means for projecting one of said stops, means for detaining said stop in its projected position, and means for preventing the rebound of the carriage, said detaining means and said means for preventing rebound being

both released by the carriage upon the arrest thereof by the cooperation of said stops.

22. In a typewriting and tabulating mechanism, the combination with a power-driven carriage and carriage-feeding devices of cooperating stops, one arranged upon the carriage and the other upon the framework, means for projecting one of said stops, a latch for detaining the projected stop in working position, and a latch for preventing rebound of the carriage.

23. In a typewriting and tabulating mechanism, the combination with a power-driven carriage and carriage-feeding devices of cooperating stops, one arranged upon the carriage and the other upon the framework, means for projecting one of said stops, a latch for detaining the projected stop in working position, and a latch for preventing rebound of the carriage, said detaining latch being moved to an inoperative position by the carriage, so that said projected stop may return to normal position, and said latch for preventing rebound of the carriage being adapted to engage the projected stop, so that upon the return of the latter to normal position the former becomes automatically disconnected therefrom.

24. In a typewriting and tabulating mechanism, the combination with a power-driven carriage and carriage-feeding devices, of a stop, a set of independently movable denomination stops cooperating with said stop, means for detaining in working position any of said denomination stops, and means cooperating with said denomination stops for preventing rebound of the carriage, said detaining means being releasable by the carriage.

25. In a typewriting and tabulating mechanism, the combination with a power-driven carriage and carriage-feeding devices of a stop upon the framework, a carriage stop, carriage-releasing devices, means for projecting one of said stops to a position where it will engage the other and simultaneously operating the said carriage-releasing devices, automatically operating means for detaining in working position both the projected stop and said carriage-releasing devices, said detaining means being releasable by the impact of the carriage, and means for preventing rebound of the carriage.

26. In a typewriting and tabulating mechanism, the combination with a power-driven carriage and carriage-feeding devices, of a stop, a cooperating stop, carriage-releasing devices, means for projecting one of said stops, means for detaining in operative position said projected stop and said carriage releasing devices, said detaining means being releasable by the carriage, and means cooperating with said projected stop for preventing rebound of the carriage.

27. In a typewriting and tabulating mechanism, the combination with a power-driven carriage and carriage-feeding devices, of a stop, a set of denomination stops cooperating therewith, carriage-releasing devices, means for detaining in operative position any of said denomination stops, together with said carriage-releasing devices, said detaining means being releasable by the carriage, and means for preventing rebound of the carriage.

28. In a typewriting and tabulating mechanism, the combination with a power-driven carriage and carriage-feeding devices, of a stop upon the framework, a carriage stop, means for projecting one of said stops to a position where it may engage the other, means for releasing the carriage from the control of its feeding devices, means for mechanically detaining said carriage-releasing means in operative position, said detaining means being releasable by the carriage, and means for preventing rebound of the carriage, the last mentioned means being rendered inoperative by the return of said projected stop to normal position.

29. In a typewriting and tabulating mechanism, the combination with a power-driven carriage and carriage-feeding devices, of a stop upon the carriage, a set of independently movable laterally-springing levers mounted upon the framework, stops carried upon the levers and projected thereby into the path of the carriage stop and also sprung thereby in a lateral direction a tooth provided upon each lever for detaining the same in its projected position, and a latch provided upon the carriage stop and adapted to engage the projected denomination stop.

30. In a typewriting and tabulating mechanism, the combination with a power-driven carriage and carriage-feeding devices, of a stop upon the carriage, a set of independently movable denomination stops mounted upon the framework, means for projecting said denomination stops, carriage-releasing devices operated by said stop-projecting means, means for causing each stop when projected to move laterally, a detent set by such lateral movement and released by the impact of the carriage stop against the denomination stop, and means for temporarily locking said carriage stop to the projected denomination stop.

31. In a typewriting and tabulating mechanism, the combination with a power-driven carriage and carriage-feeding devices of carriage-releasing devices, cooperating stops one of said stops being arranged upon the carriage and the other upon the frame, means for projecting one of said stops, means for locking the projected stop, said locking means being releasable by the carriage, and

a latch or detent carried by one of said stops and adapted to engage the other thereof.

32. In a typewriting and tabulating mechanism, the combination with a power-driven carriage and carriage-feeding devices, of a stop upon the carriage, a set of independently movable laterally-springing levers, mounted upon the framework, a carriage-releasing device operable by said levers, stops carried by said levers and projected thereby into the path of the carriage stop and also sprung thereby in a lateral direction, teeth upon the denomination stops for detaining them in their projected positions and a set of devices carried by one of said sets of stops and adapted to cooperate with the other set of stops for checking the rebound of the carriage.

33. In a typewriting and tabulating mechanism, the combination with a power-driven carriage and carriage-feeding devices, of cooperating tabulator stops, one arranged upon the carriage and the other upon the framework, and a spring pressed latch pivoted upon one of said tabulator stops and adapted to latch over the other of said stops so as to prevent rebound of the carriage.

34. In a typewriting and tabulating mechanism, the combination with a power-driven carriage and carriage-feeding devices, of a series of column stops, a series of denomination stops means for locking said denomination stops in working position, said denomination stops being releasable by the carriage, and a series of latches mounted upon said column stops and adapted to latch over the projected denomination stops so as to prevent rebound of the carriage.

35. In a typewriting and tabulating mechanism, the combination with a power-driven carriage, and carriage-feeding devices, of a rack upon the carriage, a stop 33 adjustable along said rack, a latch pivoted upon said stop, and a series of denomination stops movable into the path of said column stops and said latch.

36. In a typewriting and tabulating mechanism, the combination with a power-driven carriage and carriage-feeding devices of a stop upon the carriage a latch pivoted thereon and comprising a hooked portion 60 and a base portion 61, the latter being pivoted to said stop, a spring for said latch, and a series of denomination stops adapted to be moved into the path of said column stop and said latch.

37. In a typewriting and tabulating mechanism, the combination with a power-driven carriage and carriage-feeding devices, of a rack, a column stop thereon, a latch pivoted upon said column stop and projecting at right angles therefrom, and a series of denomination stops movable independently

into the path of said column stop and said latch.

38. In a typewriting and tabulating mechanism, the combination with a power-driven carriage and carriage-feeding devices, of cooperating stops, one arranged upon the carriage and the other upon the framework, a carriage-releasing device, means for detaining in operative position one of said stops and said carriage-releasing device, said detaining means being releasable by the impact of the carriage and a latch for preventing rebound of the carriage, said latch engaging with a part which is automatically moved out of engagement therewith upon the return of said carriage-releasing device to normal position.

39. In a typewriting and tabulating mechanism, the combination with a power-driven carriage and carriage-feeding devices controlled by a series of type-operating keys, of a carriage-releasing device, cooperative stops arranged one upon the carriage and the other upon the framework means for locking one of said stops, together with said carriage releasing device, in working position, and means for preventing the operation of said type-operating keys, after the carriage is released and before it is arrested by the contact of said stops.

40. In a typewriting and tabulating mechanism, the combination with a power-driven carriage and carriage-feeding devices controlled by a series of type-operating keys, of a carriage releasing device, a stop, a denomination stop mechanism, means for locking in working position said carriage-releasing device, and means for preventing the operation of said type-operating keys after the carriage is released and before it is arrested by the contact of said stops.

41. In a typewriting and tabulating mechanism, the combination with a power-driven carriage and carriage-feeding devices controlled by a series of type-operating keys, of a carriage-releasing device, a stop, a series of denomination stops, means for detaining any of said denomination stops in a projected position and also said carriage-releasing devices in working position, and means for preventing the operation of said type-operating keys after the carriage is released and before it is arrested by the contact of said stops.

42. In a typewriting and tabulating mechanism, the combination with a power-driven carriage and carriage-feeding devices controlled by a series of type-operating keys, of a carriage-releasing device, cooperative stops arranged one upon the carriage and the other upon the framework, means for locking one of said stops, together with said carriage-releasing device, in working position, said locking means being releasable by the

carriage, and means for preventing the operation of said type-operating keys while said carriage releasing device is locked in working position.

- 5 43. In a typewriting and tabulating mechanism, the combination with a power-driven carriage and carriage-feeding devices controlled by a series of type-operating keys, of a carriage-releasing device, a carriage stop, 10 a series of denomination stops, means for projecting said denomination stops, means for detaining said denomination stops together with said carriage-releasing device in working position, said detaining means being 15 releasable by the impact of the carriage, and means for preventing the operation of said type-operating keys while said carriage-releasing device is detained in working position.
- 20 44. In a typewriting and tabulating mechanism, the combination with a power-driven carriage and carriage-feeding devices controlled by a series of type-operating keys, of a device for preventing the operation of said 25 keys, a carriage-releasing device, means for simultaneously moving the two last-mentioned devices to working position, means for holding them there, and cooperating carriage stops.
- 30 45. In a typewriting and tabulating mechanism, the combination with a power-driven carriage and carriage-feeding devices controlled by a series of type-operating keys of a device for preventing the operation of said 35 keys, a carriage-releasing device, cooperative carriage stops, and means for simultaneously moving to working position one of said stops, said carriage-releasing device, and said device for preventing the operation of the 40 keys.
- 45 46. In a typewriting and tabulating mechanism, the combination with a power-driven carriage and carriage-feeding devices controlled by a series of type-operating keys, of a device for preventing the operation of said 45 keys, a carriage-releasing device, cooperative carriage stops, means for simultaneously moving to working position one of said stops, said carriage releasing device, and said device for preventing the operation of said 50 keys, and means for detaining the three last mentioned elements in working position, said detaining means being releasable by the carriage.
- 55 47. In a typewriting and tabulating mechanism, the combination with a power-driven carriage and carriage-feeding devices controlled by a series of type-operating keys, of a stop, a series of denomination stops, a device for preventing the operation of said 60 keys, a carriage-releasing device, means for simultaneously moving to working position the three last-mentioned elements, together with any of said denomination stops, and

means for detaining the several parts in 65 working position after such movement, said detaining means being releasable by the carriage.

48. In a typewriting and tabulating mechanism, the combination with a power-driven 70 carriage and carriage-feeding devices controlled by a series of type-operating keys, of a stop, a series of denomination stops, levers for said stops, means for detaining said levers in working position, said detaining 75 means being releasable by the carriage, a carriage-releasing bar operable by said levers, and a device which said releasing bar sets to a position for preventing the operation of said keys. 80

49. In a typewriting and tabulating mechanism, the combination with a power-driven carriage and carriage-feeding devices controlled by a series of type-operating keys, including a dog rocker, of a stop, a series 85 of denomination stops, levers for said stops, means for detaining said levers in working position, said detaining means being releasable by the carriage, a carriage-releasing bar in the path of said levers, and a device which 90 is moved by said releasing bar to a position for intercepting the movement of said dog rocker.

50. In a typewriting and tabulating mechanism, the combination with a power-driven 95 carriage and carriage-feeding devices controlled by a series of type-operating keys, including a dog rocker, of a stop upon the carriage, a series of denomination stops upon the framework, levers for said stops, means 100 for detaining said levers in working position, said detaining means being releasable by the carriage, a movable bar 47 in the path of said levers, a carriage-releasing lever 52 operated by said movable bar, a tumbler 79 upon said 105 releasing lever, and stop lug 80 upon said dog rocker.

51. A typewriter attachment having a series of auxiliary keys for disengaging the paper carriage from the step by step feeding 110 devices, a lock for locking the parts in this position against any interference from the spacing key and all type keys and a series of movable dogs for arresting the carriage at varying distances from predetermined 115 points.

52. In a typewriting and tabulating mechanism, the combination of a power driven carriage, letter-feeding mechanism therefor including two separable members, a column 120 stop, a cooperating stop, means for both projecting one of said stops and causing a disengagement of said separable members of the letter-feeding mechanism, and means for mechanically holding the projected stop 125 from returning to normal position and mechanically maintaining the disengagement of said separable members against interfer-

ence from the spacing key and all of the type keys.

53. In a typewriting machine, the combination with a tabulating stop, of two parts supported on the carriage and constructed to engage opposite sides of said stop after the carriage has been released.

54. In a typewriting machine, the combination of a carriage, a column stop, a cooperative tabulating stop, key actuated means for moving one of said stops into the path of the other, and a normally inoperative catch capable of limiting the rebound of the carriage when the latter is arrested by the cooperation of said stops.

55. In a typewriting machine, the combination of a carriage, a column stop, a cooperative tabulating stop, key actuated means for moving one of said stops into the path of the other, a normally inoperative spring-pressed catch capable of limiting the rebound of the carriage when the latter is arrested by the cooperation of said stops, and means whereby said spring-pressed catch and one of said stops is brought into position for cooperation when the stops are brought into cooperative relation.

56. In a typewriting machine, the combination of a carriage, a tabulator stop, a second cooperative tabulator stop, said stops moving one relatively to the other during the travel of the carriage, a spring-pressed catch normally out of the line of said relative movement between said stops, key actuated means for bringing the stops one into the path of the other, and means whereby an actuation of said key actuated means is also effective to bring the catch and one of said stops one into the path of the other, so that the catch will be moved against its spring pressure by the relative travel between one of said stops and said catch and an engagement between one of said stops and the catch will be effected.

57. In a typewriting machine, the combination of a carriage, an engaging device, means cooperative therewith to limit the rebound of the carriage, a tabulator key, and means whereby an actuation of the tabulator key renders said engaging device and its cooperative means operative.

58. In a typewriting machine, the combination of a carriage, an engaging device, means cooperative therewith to limit the rebound of the carriage, said engaging device and cooperative means being carried one by the carriage and the other by the frame of the machine, a tabulator key, and means whereby said cooperative means and engaging device are brought one into the path of the other by an actuation of said tabulator key.

59. In a typewriting machine, the combi-

nation of a carriage; tabulating mechanism comprising a plurality of denominational stops and key-actuated means for moving said denominational stops; and means for preventing the rebound of the carriage, said last mentioned means being rendered effective by the actuation of any of said denominational stops.

60. In a typewriting machine, the combination of a carriage, tabulating mechanism, anti-rebound device for preventing the rebound of the carriage when it is arrested by said tabulating mechanism, and means whereby the tabulating mechanism renders the anti-rebound device effective.

61. In a typewriting machine, the combination with the type keys and tabulating mechanism, of key-locking means operative on the type keys during a tabulating movement of the carriage.

62. In a typewriting machine, the combination with the type keys and tabulating mechanism, of key-locking means operative on the type keys during a tabulating movement of the carriage, and releasing mechanism operative on the key-locking means when the carriage is arrested.

63. In a typewriting machine, the combination with the type keys and tabulating mechanism comprising a tabulating key, of key-locking means operative on the type keys during a tabulating movement of the carriage, said key-locking means including a part movable by said tabulating key.

64. In a typewriting machine, the combination with the type keys and tabulating mechanism comprising a tabulating key, of key-locking means operative on the type keys during a tabulating movement of the carriage, and releasing mechanism operative on the key-locking means when the carriage is arrested, said key locking means including a part movable by said tabulating key.

65. In a typewriting machine provided with carriage feed mechanism comprising a rack and a pinion, each normally engaged with the other and one of these parts being separately movable to disengage it from the other; the combination with said carriage-feed mechanism, the type keys, and tabulating mechanism, of key-locking means operative on the type keys during a tabulating movement of the carriage, said key-locking means including a part movable simultaneously with said separately movable part of the carriage feed mechanism.

66. In a typewriting machine provided with carriage feed mechanism comprising a rack and a pinion, each normally engaged with the other and one of these parts being separately movable to disengage it from the other; the combination with said carriage feed mechanism, the type keys, and tabulat-

- ing mechanism, of key-locking means operative on the type keys during a tabulating movement of the carriage, and releasing mechanism operative on the key-locking means when the carriage is arrested, said key-locking means including a part movable simultaneously with said separately movable part of the carriage feed mechanism.
67. In a typewriting machine provided with carriage feed mechanism comprising a rack and a pinion, each normally engaged with the other and the rack being movable to disengage it from the pinion, the combination with said carriage feed mechanism, the type keys, and tabulating mechanism, of key-locking means operative on the type keys during a tabulating movement of the carriage, said key-locking means including a part movable simultaneously with said rack.
68. In a typewriting machine provided with carriage feed mechanism comprising a rack and a pinion, each normally engaged with the other and the rack being movable to disengage it from the pinion, the combination with said carriage feed mechanism, the type keys and tabulating mechanism, of key-locking means operative on the type keys during a tabulating movement of the carriage, and releasing mechanism operative on the key-locking means when the carriage is arrested, said key-locking means including a part movable simultaneously with said rack.
69. In a typewriting machine, the combination with the universal bar, and tabulating mechanism, of locking means operative on the universal bar during a tabulating movement of the carriage.
70. In a typewriting machine, the combination with the universal bar, and tabulating mechanism, of locking means operative on the universal bar during a tabulating movement of the carriage, and releasing mechanism operative on the locking means when the carriage is arrested.
71. In a typewriting machine provided with carriage feed mechanism comprising a rack and a pinion, each normally engaged with the other and one of these parts being separately movable to disengage it from the other, the combination with said carriage feed mechanism, the type keys, and tabulating mechanism, of locking means operative on said separately movable part of the carriage feed mechanism, and key-locking means operative on the type keys, each locking means being operative during a tabulating movement of the carriage, and said key-locking means including a part movable simultaneously with said separately movable part of the carriage feed mechanism.
72. In a typewriting machine provided with carriage feed mechanism comprising a rack and a pinion, each normally engaged with the other and one of these parts being separately movable to disengage it from the other, the combination with said carriage-feed mechanism, the type keys and tabulating mechanism, of locking means operative on said separately movable part of the carriage-feed mechanism, key-locking means being operative during a tabulating movement of the carriage, and releasing mechanism operative on the first mentioned locking means when the carriage is arrested, said key-locking means including a part movable simultaneously with said rack.
73. In a typewriting machine provided with carriage feed mechanism comprising a rack and a pinion, each normally engaged with the other and the rack being movable to disengage it from the pinion, the combination with said carriage feed mechanism, the type keys, and tabulating mechanism, of locking means operative on said rack, and key-locking means operative on the type keys, each locking means being operative during a tabulating movement of the carriage, and said key-locking means including a part movable simultaneously with said rack.
74. In a typewriting machine provided with carriage feed mechanism comprising a rack and a pinion, each normally engaged with the other and the rack being movable to disengage it from the pinion, the combination with said carriage feed mechanism, the type keys, and tabulating mechanism, of locking means operative on said rack, key-locking means operative on the type keys, each locking means being operative during a tabulating movement of the carriage, and releasing mechanism operative on the first mentioned locking means when the carriage is arrested, said key-locking means including a part movable simultaneously with said rack.
75. In a typewriting machine, the combination with the universal bar, and tabulating mechanism, of locking means operative on the universal bar during a tabulating movement of the carriage, said locking means including a catch, and a latch movable into engagement with the catch.
76. In a typewriting machine provided with carriage feed mechanism comprising a rack and a pinion, each normally engaged with the other and the rack being movable to disengage it from the pinion, the combination with said carriage feed mechanism, the universal bar, and tabulating mechanism, of locking means operative on the uni-

versal bar during a tabulating movement of the carriage, said locking means including a catch, and a latch movable into engagement with the catch and operative on said rack.

77. In a typewriting machine, the combination of a carriage, printing keys, key actuated tabulating mechanism including means for releasing the carriage, and means for automatically locking the printing keys against actuation when a tabulator key is actuated.

78. In a typewriting machine, the combination of a carriage, printing keys, key actuated tabulating mechanism including means for releasing the carriage, means for automatically locking the printing keys against actuation when a tabulator key is actuated, and automatically actuated releasing means controlled by the travel of the carriage for releasing said locking means.

79. In a typewriting machine, the combination of a carriage, printing keys, key actuated tabulating mechanism including carriage releasing means, means for automatically locking the carriage releasing means in released position when a tabulator key is actuated, and means for automatically locking the printing keys against actuation when a tabulator key is actuated.

80. In a typewriting machine, the combination of a carriage, printing keys, tabulating mechanism including carriage releasing means, means for automatically locking the carriage releasing means in released position when a tabulator key is actuated, means for automatically locking the printing keys against actuation when a tabulator key is actuated, and means controlled by the movement of the carriage for automatically releasing both of said locking means.

81. In a typewriting machine, the combination of a carriage, printing keys, key actuated tabulating mechanism including tabulator stops, means for automatically locking the printing keys against actuation when a tabulator key is actuated, and means controlled by the movement of the carriage for automatically releasing said locking means, the releasing means including a device which is mounted to partake of the movement of the carriage when the tabulating stops are brought into cooperation.

82. In a typewriting machine, the combination of a carriage, printing keys, tabulating mechanism including a plurality of independently operable denominational stops, and means for automatically locking the printing keys against actuation when any of said denominational stops is moved to operative position.

83. In a typewriting machine, the combination of a carriage, printing key levers, tabulating mechanism, and means for auto-

matically locking the printing key levers against actuation when the tabulator is actuated, said means including a bar cooperative with the key levers to prevent a depression thereof.

84. In a typewriting and tabulating mechanism, the combination with a carriage and carriage-feeding devices, of a stop upon the carriage, a set of denomination stops mounted upon the framework, means for projecting said denomination stops one at a time and causing the projected stop to have a limited lateral movement, and stop-detaining means set by such lateral movement.

85. In a typewriting and tabulating mechanism, the combination with a carriage and carriage-feeding devices, of a stop upon the carriage, a set of independently movable denomination-stops mounted upon the framework, means for projecting said denomination stops, means for causing each denomination stop when projected to move laterally automatically, and a detent set by such lateral movement and released by the pressure of the carriage stop against the projected denomination stop.

86. In a typewriting and tabulating mechanism, the combination with a carriage and carriage feeding devices, of a stop upon the carriage, a set of independently movable denomination stops mounted upon the framework, means for projecting said denomination stops, means for causing each denomination stop when projected to move laterally automatically, and a detent upon each denomination stop, said detent being set by such lateral movement and being released by the pressure of the carriage stop against the projected denomination stop.

87. In a typewriting and tabulating mechanism, the combination with a carriage and carriage-feeding devices, of a stop, a set of independently movable denomination stops cooperating with said stop, means for projecting said denomination stops, means for causing each denomination stop when projected to move laterally, a tooth provided upon each denomination stop, and devices engaged by said teeth upon such lateral movement.

88. In a typewriting and tabulating mechanism, the combination with a carriage and carriage-feeding devices, of a stop upon the carriage, a set of independently movable laterally springing levers mounted upon the framework, stops carried upon said levers, these levers being operative to project the last mentioned stops into the path of the carriage stop and to move them in a lateral direction, and teeth for detaining the lever-actuated stops in their projected positions.

89. In a typewriting and tabulating mechanism, the combination with a carriage and carriage-feeding devices, of a stop, a set of

independently movable levers, a guide comb for said levers, teeth upon said levers for engaging said comb teeth by a lateral movement, and stops projected by said levers.

5 90. In a typewriting and tabulating mechanism, the combination with a carriage and carriage-feeding devices, of a rack arranged longitudinally of the carriage, a column stop adjustable along said rack, a set of inde-
10 pendently movable levers, keys connected to said levers, a set of comb teeth for guiding the free ends of said levers, notches or teeth formed upon said levers in proximity to said comb teeth, and stops also formed upon said
15 levers and projected thereby into the path of the carriage stop and subsequently released automatically by the pressure of the carriage.

20 91. In a typewriting and tabulating mechanism, the combination with a carriage and carriage feeding devices, of a column stop adjustable upon the carriage, a set of levers arranged vertically in rear of the machine and fulcrumed between their ends, key-bearing push rods extending forwardly from the
25 lower ends of said levers, forwardly projecting stops formed upon the upper ends of said levers, a comb having teeth for guiding the upper ends of said levers, teeth formed
30 upon said levers for engaging said comb teeth, and means for limiting the stop projecting movements of the levers, said lever teeth engaging said comb teeth so as to detain the levers in working position, and said
35 levers being released by the carriage.

40 92. In a typewriting and tabulating mechanism, the combination with a carriage and carriage-feeding devices, of a stop, a set of denomination-stop-carrying levers, each of
45 said levers having a lateral tension, and teeth set by the lateral movement of said levers and holding the latter in working position.

50 93. In a typewriting and tabulating mechanism, the combination with a carriage and carriage-feeding devices, of a stop, a set of denomination-stop-carrying levers, each of
55 said levers having a lateral tension, and teeth set by the lateral movement of said levers and holding the latter in working position, said levers being released from the control of said teeth by the pressure of the carriage.

60 94. In a typewriting and tabulating mechanism, the combination with a carriage and carriage-feeding devices, of a stop, a set of independently movable levers, each of said levers having a lateral tension, means for guiding the hub portions of said levers, a series of stops formed upon the free ends of said levers, means for guiding said free ends, and teeth formed upon said free ends for detaining said levers in working position.

95. In a typewriting and tabulating mechanism, the combination with a carriage and carriage-feeding devices, of a carriage stop, a cooperating stop, a lever upon which one of said stops is carried, said lever having a lateral tension, a tooth, and a device engaged
70 by said tooth upon a lateral movement of said lever effected at the stop-projecting movement thereof, so as to detain said lever and projected stop in working position.

96. In a typewriting and tabulating mechanism, the combination with a power-driven carriage and carriage-feeding devices, of a stop upon the carriage, a set of independently movable laterally springing levers mounted upon the framework, carriage-releasing devices operable by said levers, stops carried upon said levers and projected there-
80 by into the path of the carriage stop and also sprung thereby in a lateral direction, and teeth for detaining the lever-actuated stops in their projected positions.

97. The combination with a typewriter carriage, feed mechanism therefor, and means for releasing the carriage from its feed mechanism, of a tabulator stop to arrest the movement of the carriage when released, a device to positively prevent rebounding movement of the carriage when arrested by said stop, and means to normally hold said device out of position to
95 engage said stop.

98. The combination with a typewriter carriage, feed mechanism therefor, and means for releasing the carriage from its feed mechanism, of a tabulator stop to arrest the movement of the carriage when released, and two parts supported on the carriage and constructed to engage opposite sides of said stop when the carriage is released, for the purpose set forth.
100

99. The combination with a typewriter carriage, feed mechanism therefor, and means for releasing the carriage from its feed mechanism, of a tabulator stop to arrest the movement of the carriage when released, means to engage the carriage with the stop adapted to positively prevent movement of the carriage in either direction, and means for releasing the carriage from the stop.
105

100. In a typewriting machine, the combination with the carriage and its feed mechanism, of a tabulator stop, means to engage said stop to arrest the movement of the carriage and means to prevent rebounding movement of the carriage when arrested, both of said means being normally out of position to engage said stop, and a key having connections for simultaneously releasing the carriage and throwing both of said means into position to engage the stop.
110

101. The combination with the frame, the carriage movable thereon, the tabulator
115

rack, the stops thereon, and means for releasing the carriage, of a detent adapted to be projected into the path of the stops on the tabulator rack when it is desired to intercept the carriage, and a rebound stop cooperating with the detent for preventing the rebounding of the carriage.

102. The combination with the frame and the carriage movable thereon, of a tabulator rack having a stop thereon, a detent adapted to cooperate with the stop to stop the car-

riage, and a second detent also arranged to cooperate with the stop to hold said stop in engagement with the first named detent.

Signed at the borough of Manhattan, city of New York, in the county of New York and State of New York, this eighth day of July, A. D. 1901.

WALTER J. BARRON.

Witnesses:

K. V. DONOVAN,
M. C. SCHULTZ.

Copies of this patent may be obtained for five cents each, by addressing the "Commissioner of Patents, Washington, D. C."