

Feb. 18, 1964

G. E. WISE

3,121,407

TOOL AND PARTS HOLDER FOR MECHANICS

Filed Jan. 5, 1961

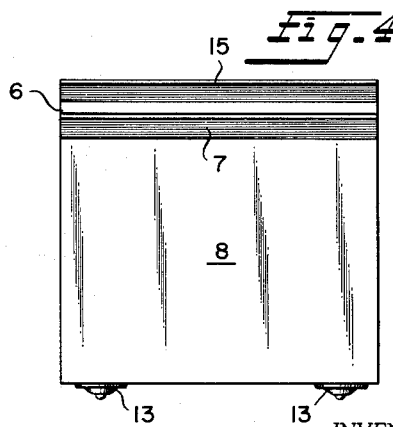
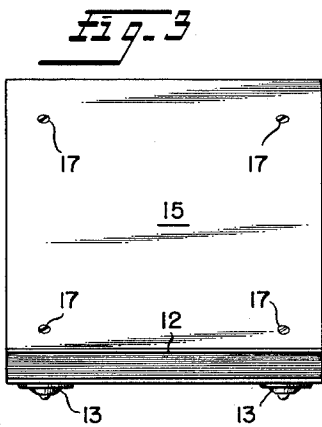
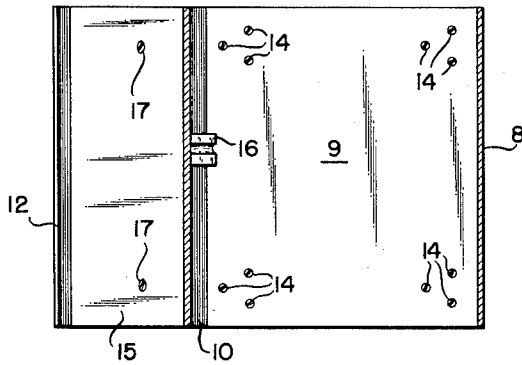
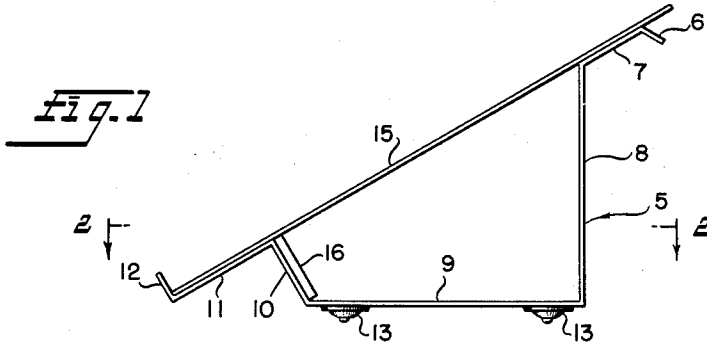

INVENTOR

Glen E. Wise

1

3,121,407

TOOL AND PARTS HOLDER FOR MECHANICS
Glenn E. Wise, 501 13th St. NW., Washington 4, D.C.
Filed Jan. 5, 1961, Ser. No. 80,819
7 Claims. (Cl. 108-32)

This invention relates to a tool and parts holder, and, more particularly, to a movable platform having a sloping magnetic surface for holding magnet-attracting tools and parts, and a horizontal surface for supporting tools and parts which are not attracted by a magnet. This device is specifically intended for use by a mechanic who is working under a vehicle while lying on a creeper, but it is not limited to such use.

When a mechanic is lying on a creeper doing repair work on a vehicle he is in an awkward position, and his movements are greatly limited by the vehicle overhead. The mechanic often further restricts his freedom of movement by placing tools and parts on the floor adjacent his creeper. These tools and parts not only get scattered around, making them hard for him to reach, but they also interfere with desired movements of the creeper since they jam under the creeper's casters or otherwise interfere with the creeper's movement.

One object of my invention is to provide a tool and parts holder which will provide a convenient support upon which a mechanic can place his tools and any necessary parts so that they will be readily accessible.

Another object of my invention is to provide a castered platform having a magnetic surface, so that magnet-attracting tools and parts placed thereon will be held in place until they are needed again.

Another object of my invention is to provide a mobile tool holder having a first surface for holding magnet-attracting tools and parts, and a second surface for supporting those tools and parts which are not attracted to a magnet.

Other objects will be apparent from the remainder of the specification and from the drawings.

In the drawings which form a part of this application:

FIGURE 1 is a side elevation of my invention;

FIGURE 2 is a sectional view taken on the line 2-2 of FIGURE 1;

FIGURE 3 is a front elevation of my invention; and,

FIGURE 4 is a rear elevation of my invention.

Referring now to FIGURES 1 to 4 by reference numerals, my tool and parts holder includes a base member, designated generally by 5. This base member, more specifically, is composed of a bent plate of non-magnetic material such as aluminum, or the like. As most clearly seen in FIGURE 1, the base member is bent so as to provide a hand-hold portion 6, an upper attaching portion 7, a rear wall 8, a bottom 9, a front wall 10, a lower attaching portion 11, and a flange 12.

To give my holder mobility, four conventional ball-type caster units 13 are attached, each adjacent a different corner of the underside of bottom 9, by flat-headed screws, as at 14. Screws 14 extend through counter-sunk apertures (not shown), in bottom 9, and mate with threaded apertures (not shown) in the caster units. Since caster units of this type are old and well known, it is not thought necessary to describe them further. Obviously other types of casters might also be used with equally good results.

A rectangular iron plate 15 lies on, and bridges the space between, portions 7 and 11. Since portion 7 is somewhat higher than portion 11, the plate is supported at a considerable angle to the horizontal for a purpose to be described shortly. The lowermost edge of plate 15 engages flange 12, as seen in FIGURE 1. The plate is fastened to portions 7 and 11 by means of flat-headed screws 17 which extend through counter-sunk apertures

2

(not shown) in the plate, and engage in tapped holes (not shown) in portions 7 and 11.

Bonded, or otherwise attached, to the underside of plate 15 and to the upper side of wall 10 is a strong bar or horseshoe type permanent magnet, shown diagrammatically at 16. Since the magnet and the plate 15 are in contact, the plate, in effect, becomes an extension of the magnet and becomes magnetized. Thus any ferrous tools or parts brought into contact with the plate will be attracted to and held on it.

The plate 15 is made to slope so that a mechanic can have a clear view of any tools or parts being held thereon while he is lying substantially flat on a creeper. The flange 12 prevents tools or parts from falling on the floor should they accidentally be dislodged from the plate 15. Base member 5 is made of non-magnetizable material so that it will not reduce the holding power of the magnet 16 or the plate 15 by draining off a portion of the magnet's or plate's magnetic field.

Having described the various elements of my invention, I will now describe one manner of using it.

A mechanic who is required to do repair work on a vehicle while lying on a creeper thereunder would first lift my invention on to his work bench, and would place all necessary tools and parts thereon. (Portion 6 can serve as a hand hold while lifting my holder.) Those tools and parts which are attracted to the magnetic plate he would place thereon, and the remainder he would place on the topside of bottom 9. After so equipping the holder, he would place it on the floor next to the vehicle which he wished to repair, and would lie down on his creeper. After positioning himself under the vehicle he would reach out and move my holder toward himself, placing it in such a position adjacent the creeper that he would have a good view of, and easy access to, all of the tools on the holder. Now he would accomplish his repair work, all the time using my invention as a convenient platform for his tools and parts. Note that he can move the holder around as he changes his work position. After finishing his work he could either remove his tools and extra parts from my holder, or he could again lift the entire device on to his work bench and use it as a tool holder in that position.

I wish to point out that I might form the magnetic means of my holder in other ways. For example, I might overcome the need for the magnet 16 by permanently magnetizing plate 15. With such an arrangement, plate 15 would serve both as an attracting and a supporting surface.

Having now described my invention, what I claim as new and desire to secure by Letters Patent is:

1. A tool and parts holder comprising: a base member, said base member including a horizontal shelf-forming bottom having a front end and a rear end, first wall-forming means attached to and extending upwardly from the front end of said bottom, and second wall-forming means spaced from said first wall-forming means and attached to and extending upwardly from the rear end of said bottom; a magnetized plate overlying said bottom, said plate having spaced portions of its underside engaging the uppermost portions of said first and second wall-forming means, respectively; caster means attached to said base member whereby said holder may be readily moved from place to place; and means attaching said plate to said base member.

2. The combination of claim 1 wherein said second wall-forming means extend substantially higher than said first wall-forming means whereby said plate slopes upwardly from front to rear.

3. The combination of claim 1 wherein said base member is constructed of a material other than a magnetizable material.

3

4. A tool and parts holder comprising: a base member, said base member including a horizontal shelf-forming bottom having a front end and a rear end, a first wall rigidly attached to and extending upwardly from the front end of said bottom, a second wall rigidly spaced from said first wall and attached to and extending upwardly from the rear end of said bottom, a first attaching portion rigidly attached to said first wall, and a second attaching portion rigidly attached to said second wall; a magnetizable plate overlying said bottom, said plate having spaced portions of its underside engaging said first and second attaching portions, respectively; magnet means underlying and engaging the underside of said plate thereby magnetizing said plate; caster means attached to said base member whereby said holder may be readily moved from place to place; and means attaching said plate to said first and second attaching portions.

5. The combination of claim 4, wherein said second wall extends substantially higher than said first wall whereby said plate slopes upwardly from front to rear, and wherein said first attaching portion extends forwardly from said first wall and said second attaching portion extends rearwardly from said second wall, and including: stop means adjacent the lower end of said plate for impeding downward movement of tools or parts support-

4

ed on said plate should said tools or parts become accidentally dislodged from said plate.

6. The combination of claim 5, said stop means comprising a flange attached to and extending upwardly from the forward end of said first attaching portion, said flange terminating in an upper end located above and adjacent the front end of said plate, and said base member further including a handle-forming portion rigidly attached to and extending rearwardly from said second attaching portion.

7. The combination of claim 4 wherein said base member is constructed of a material other than a magnetizable material.

References Cited in the file of this patent

UNITED STATES PATENTS

1,568,941	Gibson	Jan. 5, 1926
1,576,420	Folts	Mar. 9, 1926
2,016,421	Eichner	Oct. 8, 1935
2,145,879	Jewett	Feb. 7, 1939
2,517,174	Bradley	Aug. 1, 1950
2,569,926	Wein	Nov. 24, 1953
2,733,113	Humbarger	Jan. 31, 1956
2,799,399	Cannon	July 16, 1957
2,894,640	Bigelow	July 14, 1959