

(19) AUSTRALIAN PATENT OFFICE

(54) Title
Multiple pack and method of producing same

(51)⁶ International Patent Classification(s)
B65D 77/08 (2006.01)77/20
B65D 77/20 (2006.01)20060101ALI2005100
B65D 81/32 (2006.01)⁸BMEP **B65D**
B65D 77/08 81/32
20060101AFI2005122 20060101ALI2005100
0BMJP **B65D** ⁸BMEP
PCT/EP03/00214

(21) Application No: 2003206713

(22) Application Date: 2003 .01 .13

(87) WIPO No: W003/064282

(30) Priority Data

(31) Number	(32) Date	(33) Country
102 03 448.6	2002 .01 .30	DE

(43) Publication Date : 2003 .09 .02

(43) Publication Journal Date : 2003 .09 .18

(71) Applicant(s)
Mars Incorporated

(72) Inventor(s)
Nehus, Uwe, Kiel, Hans-Richard, De Turckheim, Bernard

(74) Agent/Attorney
Watermark Patent & Trademark Attorneys, 302 Burwood Road, Hawthorn, VIC, 3122

(56) Related Art
GB 2242410
GB 2297536
US 5843501
US 3945170
US 4339033
EP 677454

(12) INTERNATIONAL APPLICATION PUBLISHED UNDER THE PATENT COOPERATION TREATY (PCT)

(19) World Intellectual Property Organization
International Bureau



(43) International Publication Date
7 August 2003 (07.08.2003)

PCT

(10) International Publication Number
WO 03/064282 A2

- (51) International Patent Classification: **B65D 81/32**
- (21) International Application Number: PCT/EP03/00214
- (22) International Filing Date: 13 January 2003 (13.01.2003)
- (25) Filing Language: English
- (26) Publication Language: English
- (30) Priority Data:
102 03 448.6 30 January 2002 (30.01.2002) DE
- (71) Applicant (for all designated States except US):
MARS INCORPORATED [US/US]; 6885 Elm Street,
22101-3883 McLean (US).
- (72) Inventors; and
(75) Inventors/Applicants (for US only): **KIEL,
Hans-Richard** [DE/DE]; Elbinger Strasse 66, 28876
Oyten (DE). **NEHUS, Uwe** [DE/DE]; Andreaswall
16, 27283 Verden (DE). **DE TURCKHEIM, Bernard**
[FR/FR]; 775, rue Heme, F-45160 Olivet (FR).
- (74) Agents: **BOEHMERT & BOEHMERT; WINKLER,**
Andreas, Hollerallee 32, 28209 Bremen et al. (DE).
- (81) Designated States (national): AE, AG, AL, AM, AT, AU,
AZ, BA, BB, BG, BR, BY, BZ, CA, CH, CN, CO, CR, CU,
CZ, DE, DK, DM, DZ, EC, EE, ES, FI, GB, GD, GE, GH,
GM, HR, HU, ID, IL, IN, IS, JP, KE, KG, KP, KR, KZ, LC,
LK, LR, LS, LT, LU, LV, MA, MD, MG, MK, MN, MW,
MX, MZ, NO, NZ, OM, PH, PL, PT, RO, RU, SD, SE, SG,
SK, SL, TJ, TM, TN, TR, TT, TZ, UA, UG, US, UZ, VN,
YU, ZA, ZM, ZW.
- (84) Designated States (regional): ARIPO patent (GH, GM,
KE, LS, MW, MZ, SD, SL, SZ, TZ, UG, ZM, ZW),
Eurasian patent (AM, AZ, BY, KG, KZ, MD, RU, TJ, TM),
European patent (AT, BE, BG, CH, CY, CZ, DE, DK, EE,
ES, FI, FR, GB, GR, HU, IE, IT, LU, MC, NL, PT, SE, SI,
SK, TR), OAPI patent (BF, BJ, CF, CG, CI, CM, GA, GN,
GQ, GW, ML, MR, NE, SN, TD, TG).
- Published:**
without international search report and to be republished
upon receipt of that report
- For two-letter codes and other abbreviations, refer to the "Guidance Notes on Codes and Abbreviations" appearing at the beginning of each regular issue of the PCT Gazette.*



WO 03/064282 A2

(54) Title: MULTIPLE PACK AND METHOD OF PRODUCING SAME

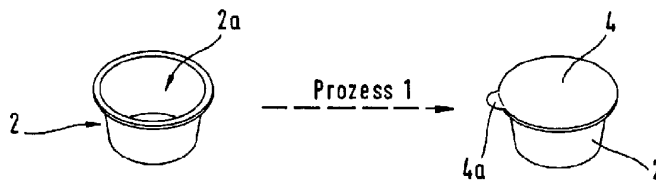

(57) Abstract: Method of producing a multiple pack subdivided into at least two chambers separate from one another and each containing a product, characterised in that a first pack element having at least one chamber containing a first product is subjected to a first treatment process and is sealed, either previously or subsequently, and a second pack element having at least one chamber containing a second product is subjected to a second treatment process, which is different from the first, and is sealed, either previously or subsequently, and that the two pack elements are assembled into one unit to form the multiple pack.

MULTIPLE PACK AND METHOD OF PRODUCING SAME

The invention relates to a method of producing a multiple pack subdivided into at least two chambers separate from one another and each containing a product. The invention further relates to a multiple pack with at least two
5 chambers separate from one another and each containing a product, where the multiple pack has been produced in accordance with the method of the invention.

In conventional multiple packs, e.g. in the form of bowls subdivided into a plurality of compartments or chambers, the manufacturing process leads to problems, when the compartments are filled with different products, if the
10 respective properties of the different products mean that they are subjected to production or treatment processes which are basically different or that they would have to be managed or handled differently in some other way even though this is difficult or impossible because of the fact that the individual products are located in one and the same multiple bowl or multiple pack. So far, it has been tolerated
15 that different products are treated uniformly and thus not ideally, so that in the case of a multiple pack containing a ready-made meal for example, the different components, e.g. vegetables and meat, are cooked for the same length of time and thus not ideally.

The object of the invention is to provide a method of producing a multiple
20 pack with which the above-mentioned problems can be overcome.

This object is achieved, in accordance with the invention, by a method of producing a multiple pack subdivided into at least two chambers separate from one another and each containing a product, the method comprising:

in a first step, a first pack element having at least one first chamber for
25 receiving at least one first product is filled with at least one first product in a first process in which the first process includes a first treatment step comprising a sterilization step or a preservation step that takes place within the at least one first chamber,

in a second step, a second pack element with at least one second
30 chamber for receiving at least one second product is filled with at least one second product in a second process in which the second process includes a second treatment step comprising a sterilization step, a preservation step or a cooking step that takes place within the at least one second chamber; and

in a third step, the two pack elements are assembled into one unit to form the multiple pack and are joined together, either releasably or non-releasably, the chambers of the pack elements being sealed before or after the third step;

5 wherein the process of the second treatment step is different from the process of the first treatment step.

The aim of the present invention is to achieve/overcome at least one of the respective objects/prior art disadvantages referred to herein.

10 It is conveniently provided for the first process to be different from the second process with regard to at least one process characteristic or one process parameter, especially sterility, temperature or temperature development, pressure or pressure development, intensity of any irradiation (visible or invisible light, high-energy electromagnetic radiation), blending of additives, handling steps, or transport speed.

15 It can be provided for at least one of the processes to involve a preservation or sterilisation step.

It is preferably provided for at least one chamber of a pack element to be sealed before the completion of the process concerned.

It is preferably provided for the chamber concerned to be sealed such that it is diffusion-tight during the preservation or sterilisation step.

20 It can be provided for at least one chamber of a pack element to be sealed with a closure film.

In a second appropriate embodiment, two pack elements are provided with one chamber each.

25 In a further development of the invention, it can be provided for the pack elements to engage with one another, and/or to be bonded and/or welded together.

30 It is preferably provided for the multiple pack to be sealed, after the pack elements have been joined together, with a closure film covering all the pack elements. In the process, it can also be provided for the closure film to serve at the same time as a means of sealing one of the pack elements. In this context, it can in particular be provided for at least one of, preferably all, the

pack elements to be sealed with sealing films and for the closure film also to be sealed with the sealing films of the pack elements, so that, when the closure film is opened, the sealing films of all the pack elements can be opened in a single step.

The object of the invention is further achieved by a multiple pack with at least two chambers separate from one another and each containing a product, wherein the multiple pack is produced according to the method of the invention, and it can in particular be provided for a second pack element to be designed as a bowl pack with a receptacle for a first, especially bowl-shaped pack element. In this context, it can be provided for the second pack element to be of a freely chosen shape, in particular round, polygonal or substantially rectangular, and to have a receptacle opening of a freely chosen shape, in particular round, polygonal or substantially rectangular, to receive the first pack element which is to be placed in it and which is also of a freely chosen shape, in particular round, polygonal or substantially rectangular.

It is preferably provided for the chambers to have volumes in a ratio of 1:1 to 1:10, in particular up to 1:4.

The invention will now be explained by means of a working embodiment, with reference being made to a drawing in which

Figs. 1 and 2 illustrate the two different processes;

Fig. 3 shows the assembly of the multiple pack; and

Fig. 4 shows the attachment of a closure film.

Figs. 1 to 4 show schematically, from top to bottom, major production steps for a multiple pack in accordance with the invention, which is illustrated at the bottom right of the drawing and is designated as a whole by reference numeral 10.

Fig. 1 shows a first pack element 2, which in principle can be of any freely chosen shape (e.g. round, polygonal or square in layout) and in the present case is in the shape of a round bowl, tapering into a slightly conical shape at the bottom, with a first chamber 2a. In a (first) process 1, which can be a filling, handling, transport, treatment and/or other process, the bowl 2 is filled with a product, e.g. a(n) (animal) food product and, at any convenient time, e.g. at the end of the process or before a particular treatment step, sealed with a first sealing film 4. It can, for example, be provided for the bowl 2 with the product contained therein to undergo a sterilisation or preservation process, during which the product is exposed to a sterilisation temperature of 120 to 130° C over a period of about 30 to 60 minutes.

Alternatively, the process 1 could consist merely in a particular step of handling or transporting the bowl, connected with filling with a desired product, without any particular treatment occurring. The bowl might, for example, merely be filled with a product under sterile or aseptic conditions and subsequently sealed. The essential feature is only that the bowl 2 and the product to be placed therein should be capable of being handled and optionally treated or processed independently of one or more other pack elements and products.

Fig. 2 shows a second pack element 6 with a second chamber 6a for receiving a product, and again said second pack element 6 can in principle also be of any freely chosen shape and in the present example is designed as a square bowl with a receptacle opening 5 for the first pack element 2. The second pack element 6 undergoes a (second) process 2 and is filled with a product, e.g. a(n) (animal) food product, and is sealed with a second sealing film 8, also that, by analogy with the process 1, the filled, optionally treated and sealed pack element 6 is left at the end of the process 2. In the case of process 2 as well, any desired handling, filling, treatment and/or other steps can be provided, the sealing of the pack element 6 being performed at any convenient point of the process. The process 2 can, for example, consist of or include a sterilisation or preservation process, or it might be a cooking process. Here too, the essential feature is that process 2

takes place independently of process 1, i.e. the pack element 6 can be handled, filled and treated etc. independently of the pack element 2, and that the two processes differ from one another in at least one process parameter. This might be a different process step or also a different physical parameter (temperature, pressure, duration etc.). The sealing films 4, 8 are made of a material which, as far as possible, is diffusion-tight even under the conditions prevailing during the various treatment processes (metallised plastics, metal films or the like). Opening tabs 4a, 8a facilitate lifting the films later.

Fig. 3 shows how the two pack elements 2 and 6 are assembled after completion of the two processes and joined together into a unit, so that a single multiple pack is formed, which can be handled (transported, stored, sold etc.) as a unit. It is convenient for the first pack element 2, as in the present example, to be inserted into a corresponding receptacle opening 5 of the second pack element 6 (arrows 7). The two pack elements are fixed to one another, e.g. by means of a firm fit (press fit), engaging, welding, bonding, sealing etc. .

As Fig. 4 shows, this example involves a further step, in which a closure film 9 covering the two pack elements is applied, which in the present example is rectangular or square and is sealed onto the rims of the second pack element. In order to improve handling when opening, it can in addition be provided for the closure film 9 to be firmly sealed to the edges of one or both sealing films 4 and 8 respectively, so that when the closure film 9 is opened (opening tab 9a) the two pack elements or bowls 2, 6 can be opened at the same time in one go. If the content of bowl 2 is to be emptied into bowl 6 after opening, in order, for example, to mix the two contents together, this can be done in one embodiment by removing bowl 2. On the other hand, it is also possible to provide notches, perforations or weakened lines in the region around the receptacle opening 5, in order to facilitate folding this region (including bowl 2) over bowl 6.

As a rule, it will be provided for the individual pack elements of the multiple pack to be sealed during or at the end of processes 1 and 2. Alternatively, however, it can also be provided for the pack elements to be assembled in an unsealed state and only when assembled to be sealed with one or more films. In this case, the film 9 may replace one or optionally even both individual films 4, 8.

The decisive advantage of the method of the invention consists in the fact that two or more product components of a multiple pack can be subjected to different handling, treatment or manufacturing processes, in which they are exposed to different process parameters and can be handled separately from one another before finally being assembled into a single multiple pack.

THE CLAIMS DEFINING THE INVENTION ARE AS FOLLOWS:

2003206713 25 Mar 2009

1. A method of producing a multiple pack subdivided into at least two chambers separate from one another and each containing a product, the method comprising:
 - 5 in a first step, a first pack element having at least one first chamber for receiving at least one first product is filled with at least one first product in a first process in which the first process includes a first treatment step comprising a sterilization step or a preservation step that takes place within the at least one first chamber,
 - 10 in a second step, a second pack element with at least one second chamber for receiving at least one second product is filled with at least one second product in a second process in which the second process includes a second treatment step comprising a sterilization step, a preservation step or a cooking step that takes place within the at least one second chamber; and
 - 15 in a third step, the two pack elements are assembled into one unit to form the multiple pack and are joined together, either releasably or non-releasably, the chambers of the pack elements being sealed before or after the third step;
wherein the process of the second treatment step is different from the process of the first treatment step.
- 20 2. Method as claimed in claim 1, wherein the first process is different from the second process with regard to at least one process characteristic or one process parameter selected from the group consisting of sterility, temperature, temperature development, pressure, pressure development, intensity of any irradiation, blending of additives, handling steps and transport speed.
- 25 3. Method as claimed in claim 2, wherein the intensity of any radiation is selected from the group consisting of visible light, invisible light and high-energy electromagnetic radiation.
4. Method as claimed in any one of claims 1 to 3, wherein at least one of the processes involves a preservation, a sterilisation step or a cooking step.

5. Method as claimed in any one of the preceding claims, wherein at least one chamber of a pack element is sealed before the completion of the process concerned.
6. Method as claimed in claim 5, wherein the chamber concerned is sealed such that it is diffusion-tight during the preservation or sterilisation step.
7. Method as claimed in any one of the preceding claims, wherein at least one chamber of a pack element is sealed with a sealing film.
8. Method as claimed in any one of the preceding claims, wherein there are two pack elements with one chamber each.
9. Method as claimed in any one of the preceding claims, wherein the pack elements engage with one another.
10. Method as claimed in claim 9, wherein the pack elements are bonded or welded together.
11. Method as claimed in any one of the preceding claims, wherein the multiple pack is sealed, after the pack elements have been joined together, with a closure film covering all the pack elements.
12. The method as claimed in claim 11, wherein the closure film serves at the same time as a means of sealing one of the pack elements.
13. Method as claimed in claim 11 or claim 12, wherein at least one of the pack elements is/are sealed with sealing films and the closure film is sealed together with the sealing films of the pack elements, so that, when the closure film is opened, the sealing films of all the pack elements can be opened in a single step.
14. Method as claimed in claim 12, wherein all the pack elements are sealed with sealing films.

2003206713 25 Mar 2009

9

15. A multiple pack with at least two chambers separate from one another and each containing a product, manufactured in accordance with the method as claimed in any one of the preceding claims.
- 5 16. The multiple pack as claimed in claim 15, wherein the second pack element is designed as a bowl pack with a receptacle for a first pack element.
17. The multiple pack as claimed in claim 16, wherein the first pack element is bowl-shaped.
- 10 18. The multiple pack as claimed in claim 16 or claim 17, wherein the second pack element has a shape selected from a group consisting of a round, polygonal and square in layout and has a receptacle opening of corresponding to the shape of second pack element, to receive the first pack element which is to be placed in it and which has a shape selected from a group consisting of a round, polygonal and square in layout.
- 15 19. The multiple pack as claimed in any one of claims 15 to 18, wherein the chambers have volumes in a ratio of 1:1 to 1:10.
20. The multiple pack as claimed in claim 19, wherein the chambers have volumes in a ratio of 1:4.

MARS, INCORPORATED

WATERMARK PATENT & TRADE MARK ATTORNEYS

P24378AU00

1/1

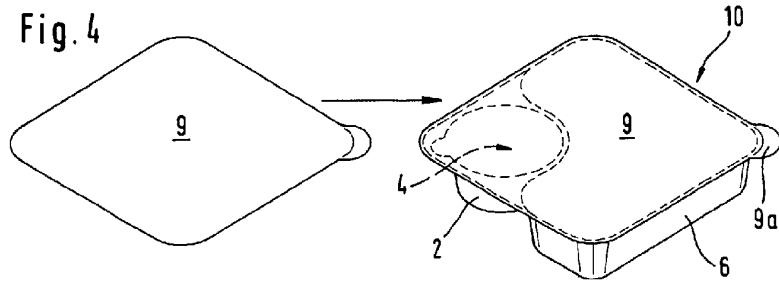
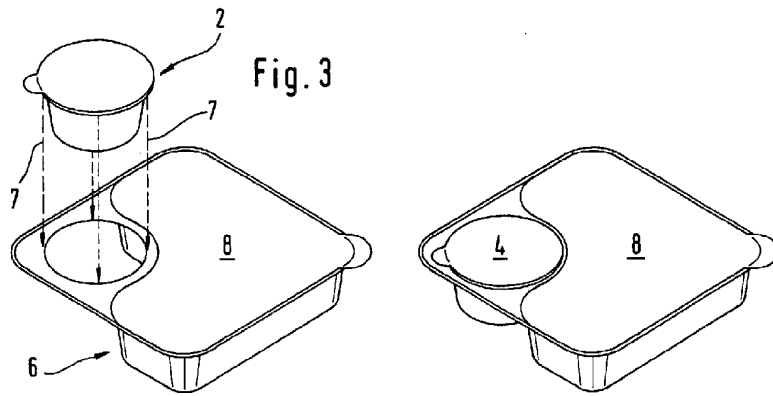
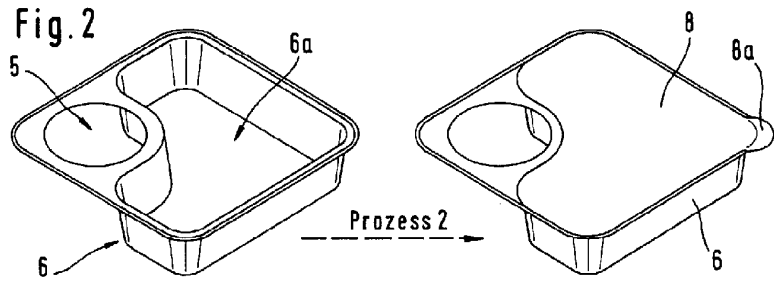
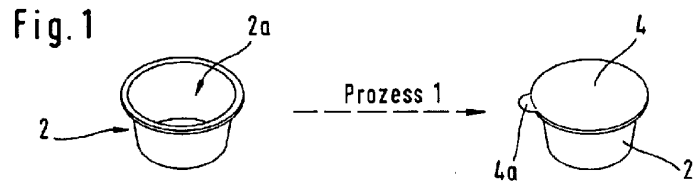

SUBSTITUTE SHEET (RULE 26)