



US00D785543S

(12) **United States Design Patent**
Suzuki

(10) **Patent No.:** **US D785,543 S**

(45) **Date of Patent:** **** May 2, 2017**

(54) **AUTOMOBILE TIRE**

(71) Applicant: **THE YOKOHAMA RUBBER CO., LTD.**, Minato-ku, Tokyo (JP)

(72) Inventor: **Naoko Suzuki**, Hiratsuka (JP)

(73) Assignee: **THE YOKOHAMA RUBBER CO., LTD.**, Minato-ku, Tokyo (JP)

(**) Term: **15 Years**

(21) Appl. No.: **29/542,463**

(22) Filed: **Oct. 14, 2015**

(30) **Foreign Application Priority Data**

Apr. 15, 2015 (JP) 2015-008579

(51) **LOC (10) Cl.** **12-15**

(52) **U.S. Cl.**
USPC **D12/520**

(58) **Field of Classification Search**

USPC D12/519-532, 551-567, 586-603
CPC B60C 1/0016; B60C 11/0302-11/0318;
B60C 11/11-11/13; B60C 3/06; B60C
9/17; B60C 2200/10

See application file for complete search history.

(56) **References Cited**

U.S. PATENT DOCUMENTS

D439,870 S * 4/2001 Lovell D12/519
D515,019 S * 2/2006 Umstot D12/519
D585,813 S * 2/2009 Lee D12/519

D666,964 S * 9/2012 Ishida D12/519
D667,360 S * 9/2012 Ishida D12/523
D676,801 S * 2/2013 Scheifele D12/587

* cited by examiner

Primary Examiner — Cathron Brooks

Assistant Examiner — Ian Whitmore

(74) *Attorney, Agent, or Firm* — Banner & Witcoff, Ltd.

(57) **CLAIM**

The ornamental design for an automobile tire, as shown and described.

DESCRIPTION

FIG. 1 is a perspective view of an automobile tire showing our new design;

FIG. 2 is a front view thereof;

FIG. 3 is a rear view thereof;

FIG. 4 is a right side view thereof;

FIG. 5 is a left side view thereof;

FIG. 6 is a top view thereof;

FIG. 7 is a bottom view thereof;

FIG. 8 is a partially enlarged view of a portion defined by lines 8-8 shown in FIG. 1;

FIG. 9 is a partially enlarged view of a portion defined by lines 9-9 shown in FIG. 2; and,

FIG. 10 is a cross sectional view of a portion defined by lines 10-10 shown in FIG. 9.

The dashed broken lines illustrate the tire sidewall and inner bead and form no part of the claimed design. The dot-dash lines illustrate the peripheral boundary of the claimed design and form no part thereof.

1 Claim, 10 Drawing Sheets

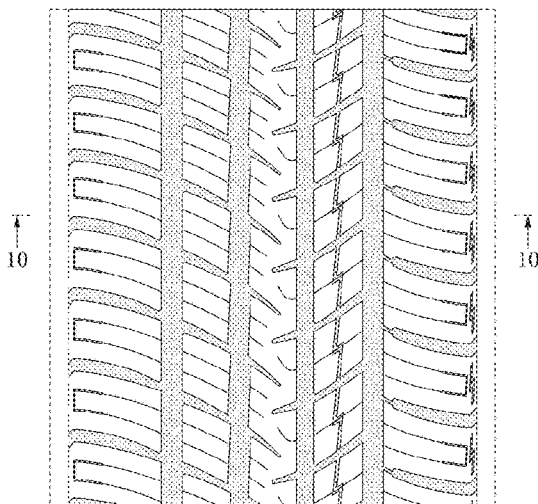
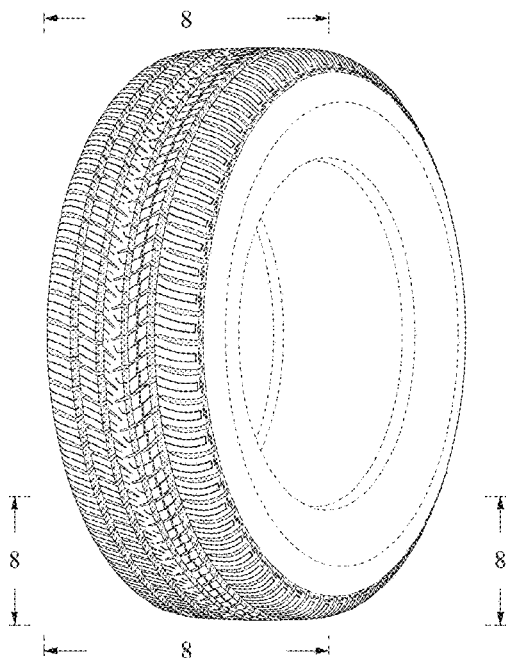

FIG. 1

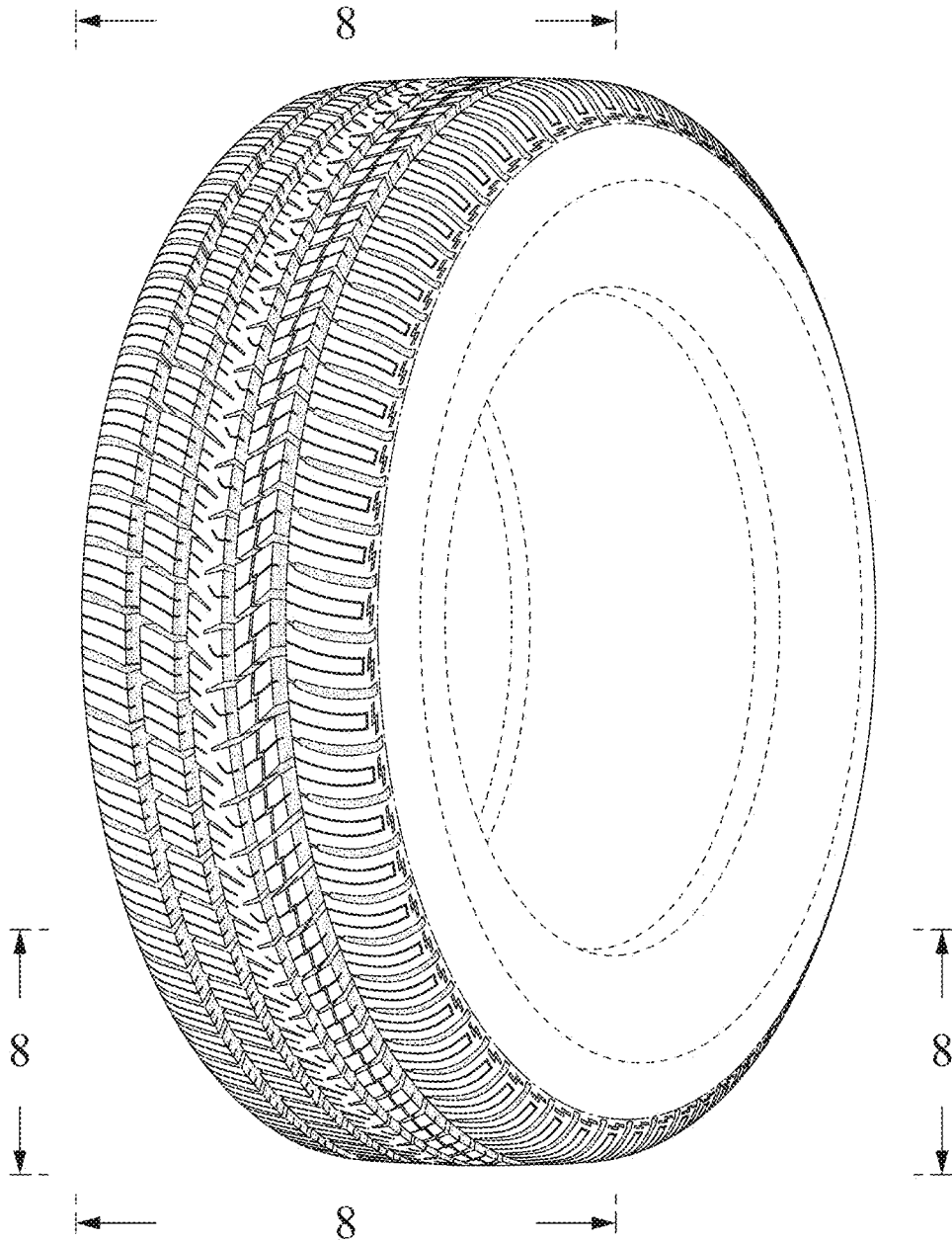

FIG. 2

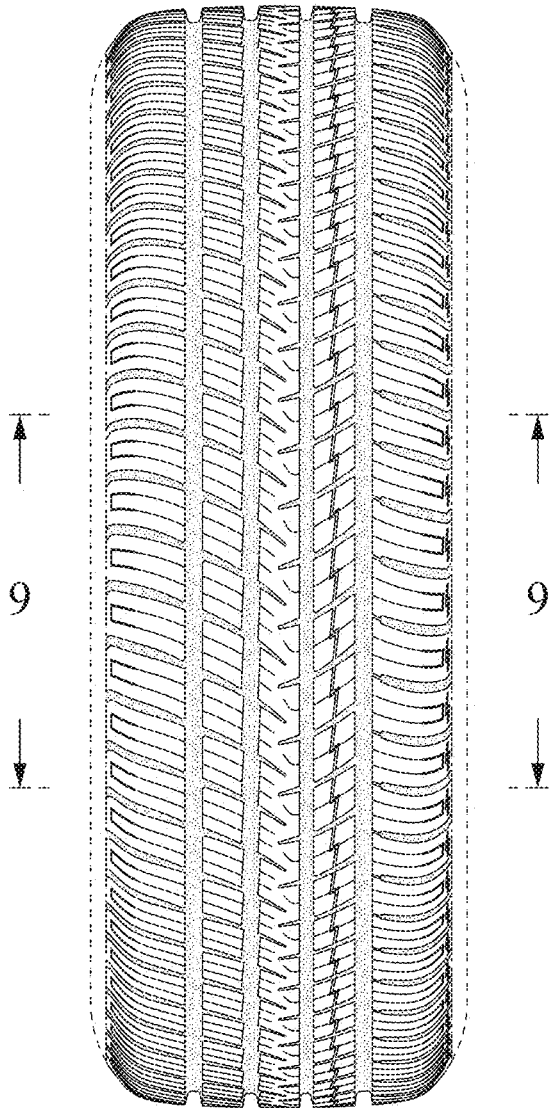

FIG. 3

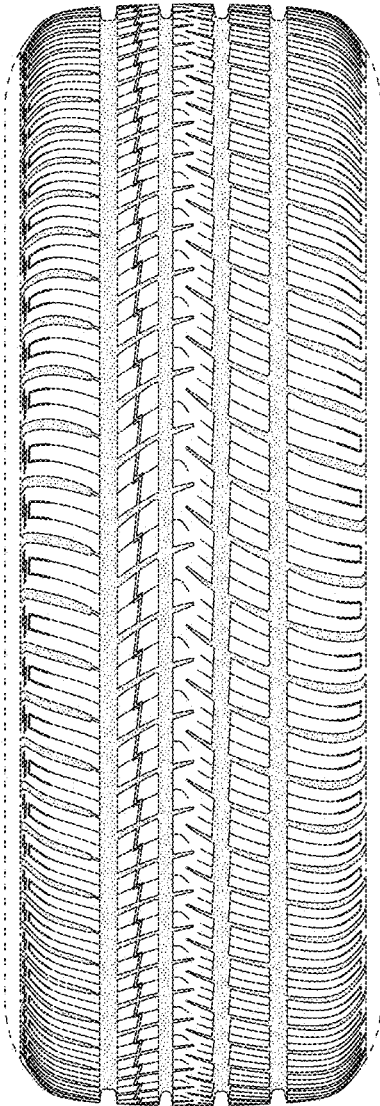

FIG. 4

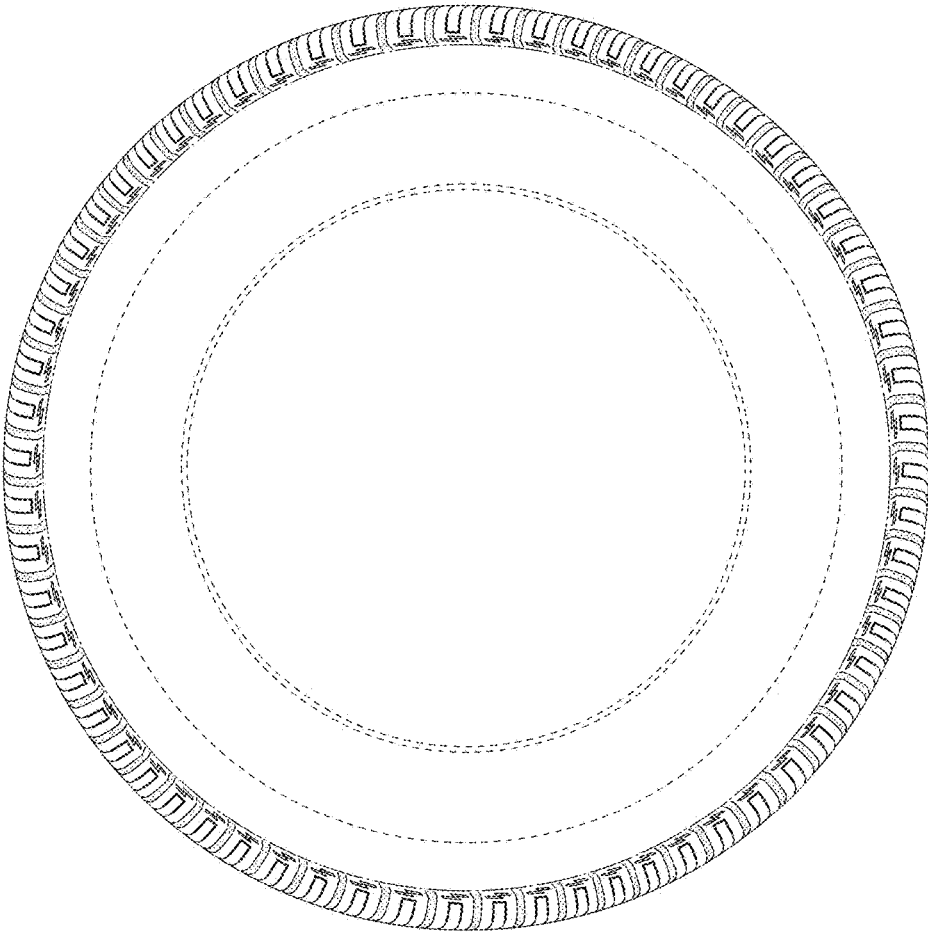

FIG. 5

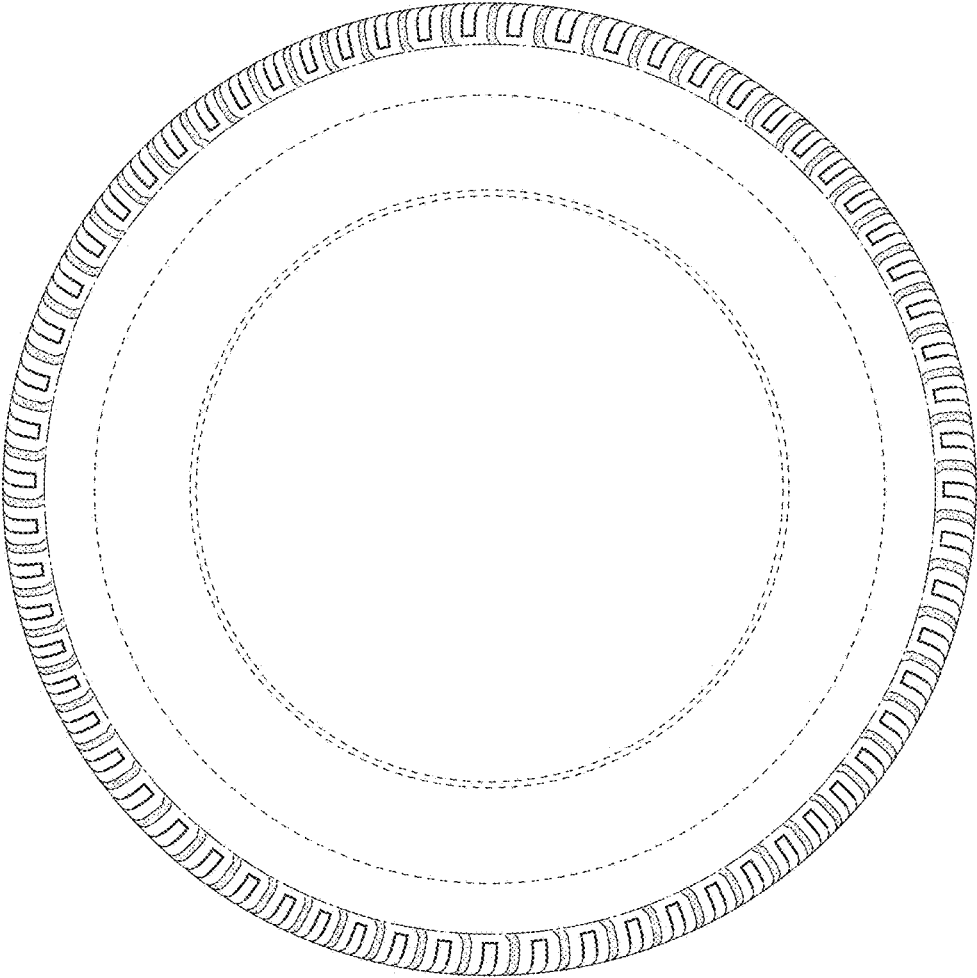

FIG. 6

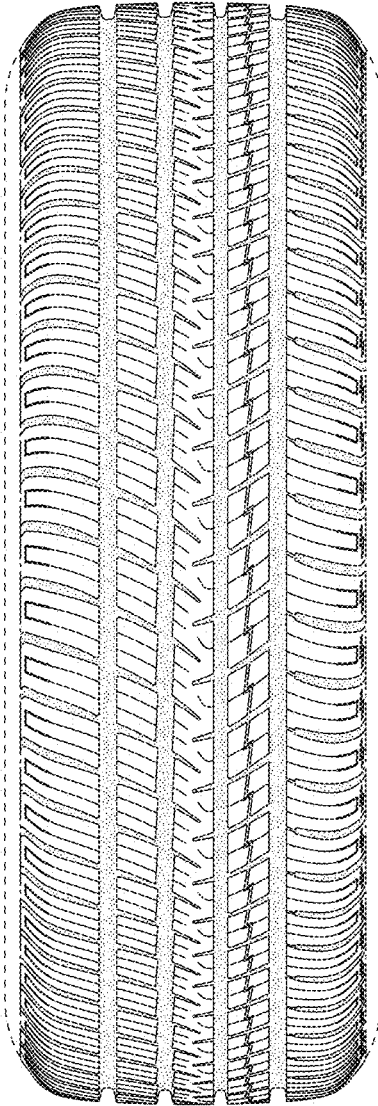

FIG. 7

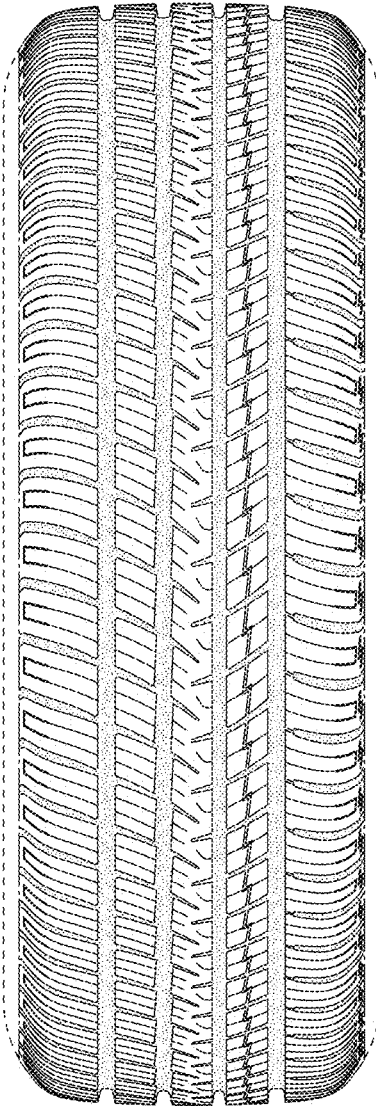

FIG. 8

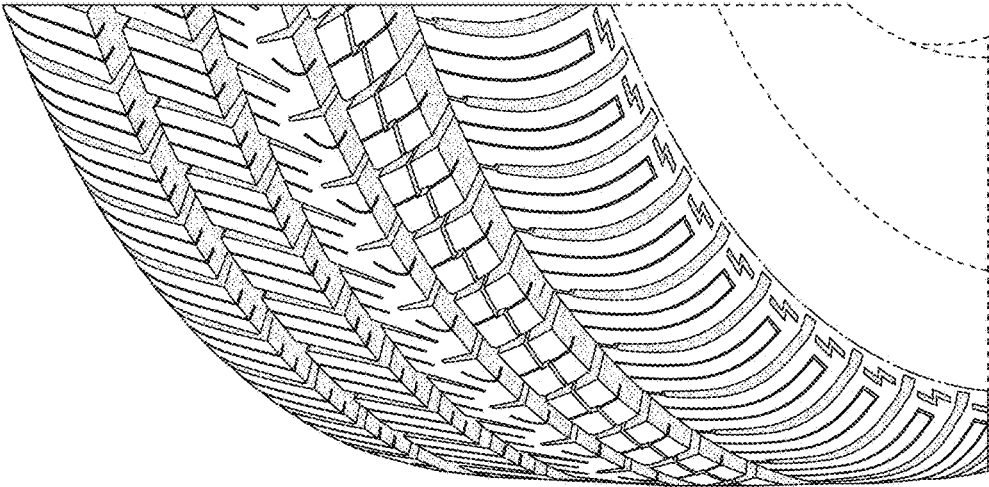

FIG. 9

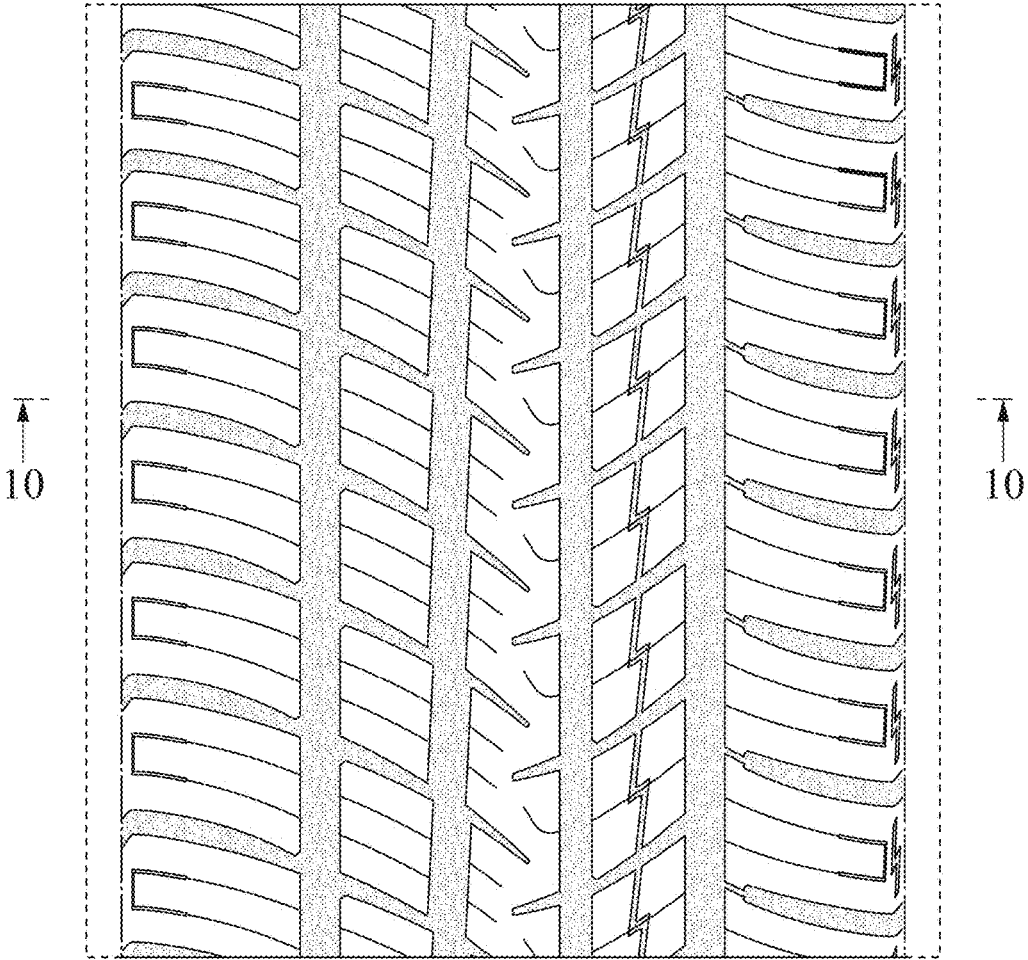

FIG. 10

