

(19) World Intellectual Property Organization
International Bureau



(43) International Publication Date
22 February 2007 (22.02.2007)

PCT

(10) International Publication Number
WO 2007/020331 A1

- (51) International Patent Classification:
B29C 53/60 (2006.01)
- (21) International Application Number:
PCT/FI2006/050358
- (22) International Filing Date: 17 August 2006 (17.08.2006)
- (25) Filing Language: Finnish
- (26) Publication Language: English
- (30) Priority Data:
20055440 19 August 2005 (19.08.2005) FI
- (71) Applicant (for all designated States except US): **PAROC GROUP OY AB** [FI/FI]; Neilikkatie 17, FI-01300 Vantaa (FI).
- (72) Inventors; and
- (75) Inventors/Applicants (for US only): **KARJALAINEN, Erkki** [FI/FI]; Soskuankatu 13b, FI-53300 Lappeenranta (FI). **NIKKINEN, Matti** [FI/FI]; Orontie 7, FI-53500 Lappeenranta (FI). **SKIPPARI, Sami** [FI/FI]; Kujan-suu 11, FI-53500 Lappeenranta (FI). **BULUT, Pirkko** [FI/FI]; Mustikkapolku 3, FI-53300 Lappeenranta (FI). **MANNINEN, Jukka** [FI/FI]; Reunakatu 55, FI-53500 Lappeenranta (FI). **KUUKKA, Ossi** [FI/FI]; Mäntyläntie 12, FI-53650 Lappeenranta (FI).
- (74) Agent: **LEITZINGER OY**; Tammasaarenkatu 1, FI-00180 Helsinki (FI).
- (81) Designated States (unless otherwise indicated, for every kind of national protection available): AE, AG, AL, AM, AT, AU, AZ, BA, BB, BG, BR, BW, BY, BZ, CA, CH, CN, CO, CR, CU, CZ, DE, DK, DM, DZ, EC, EE, EG, ES, FI, GB, GD, GE, GH, GM, HN, HR, HU, ID, IL, IN, IS, JP, KE, KG, KM, KN, KP, KR, KZ, LA, LC, LK, LR, LS, LT, LU, LV, LY, MA, MD, MG, MK, MN, MW, MX, MY, MZ, NA, NG, NI, NO, NZ, OM, PG, PH, PL, PT, RO, RS, RU, SC, SD, SE, SG, SK, SL, SM, SV, SY, TJ, TM, TN, TR, TT, TZ, UA, UG, US, UZ, VC, VN, ZA, ZM, ZW.
- (84) Designated States (unless otherwise indicated, for every kind of regional protection available): ARIPO (BW, GH, GM, KE, LS, MW, MZ, NA, SD, SL, SZ, TZ, UG, ZM, ZW), Eurasian (AM, AZ, BY, KG, KZ, MD, RU, TJ, TM), European (AT, BE, BG, CH, CY, CZ, DE, DK, EE, ES, FI, FR, GB, GR, HU, IE, IS, IT, LT, LU, LV, MC, NL, PL, PT, RO, SE, SI, SK, TR), OAPI (BF, BJ, CF, CG, CI, CM, GA, GN, GQ, GW, ML, MR, NE, SN, TD, TG).
- Published:**
- with international search report
 - before the expiration of the time limit for amending the claims and to be republished in the event of receipt of amendments
- For two-letter codes and other abbreviations, refer to the "Guidance Notes on Codes and Abbreviations" appearing at the beginning of each regular issue of the PCT Gazette.

(54) Title: APPARATUS AND METHOD FOR CONTINUOUS MANUFACTURE OF A MINERAL WOOL PIPE SECTION FOR INSULATING PURPOSES

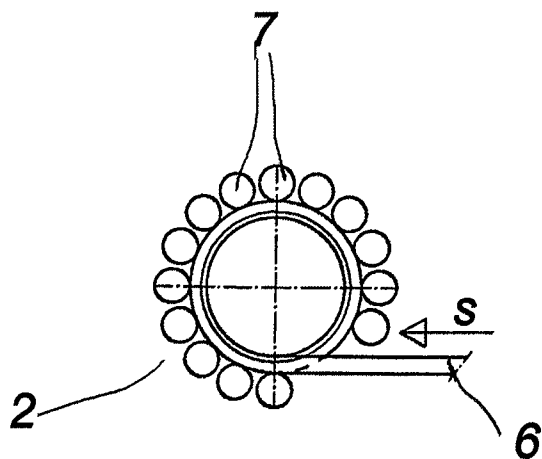

(57) Abstract: An apparatus for the continuous manufacture of a mineral wool pipe section for insulating purposes, said apparatus comprising a core and an outer roller assembly surrounding it at least partially, said roller assembly including at least two rollers, whereby a wool mat of designated length between the core and the roller assembly is windable around the core for forming a pipe section preform, one end of the core being clear for removing a formed pipe section from the core, as well as curing elements for curing the pipe section preform prior to a removal from the core off the core's clear end. At least a portion of the core is screw-shaped, the advancement of a formed portion of the pipe section along the core and finally off the core taking place in response to rotational motions of both the core's screw-shaped portion and the roller assembly.

WO 2007/020331 A1

Apparatus and method for continuous manufacture of a mineral wool pipe section for insulating purposes

An object of this invention is an apparatus for continuous manufacture of a mineral wool pipe section for insulating purposes, said apparatus comprising a core and an
5 outer roller assembly surrounding it at least partially, said roller assembly comprising at least two rollers, whereby a mineral wool mat of designated length between the core and the roller assembly is windable around the core for forming a pipe section preform, one end of the core being clear for removal of a formed pipe
10 section from the core, as well as curing elements for curing the pipe section preform prior to a removal from the core off the core's clear end.

Another object of this invention relates to a method for continuous forming of a mineral wool pipe section for insulating purposes, comprising
15 - feeding a mineral wool mat around a core, which is clear at one of its ends, in such a manner that the subsequent mat lap at least partially overlaps the preceding mat lap
- compressing the mineral mat fed around the core against the core by means of an outer roller assembly consisting of at least two rollers for producing a pipe section
20 preform
- curing the formed pipe section preform.

At present, production on a pipe section processing line is typically arranged in such a way that a mat of designated length is driven around a core and the resulting
25 intermediate product is further processed into a finished pipe section as the process proceeds. A problem in such systems is that the production process is cyclic and the products show density fluctuations and, also, the products always have a standard length. In addition, the consumption of raw material is rather considerable due to further processing of the intermediate product. Neither does such a system allow
30 for a reduction of time per piece without extensive re-structuring.

On the other hand, the prior art does include a Finnish publication print FI 50898, which indeed describes an apparatus for continuously manufacturing a pipe section, but this apparatus is nevertheless unnecessarily complicated structurally with its
35 multitude of moving parts and bulky construction. Features noted as particularly

complicated include curing the insulation piece of a tubular pipe section preform, effected by means of a hot gas, as well as a drawing device intended for advancing a tubular insulation product along and finally off a core. The advancement of the tubular insulation product along the core, as well as the control of its density, would also seem uncertain and unreliable in this prior art solution.

It is an object of this invention to provide an apparatus and method for avoiding the foregoing drawbacks.

10 In order to accomplish this, the apparatus of the invention is characterized in that at least a portion of the core is screw-shaped, the advancement of a formed portion of the pipe section along the core and finally off the core taking place in response to rotational motions of both the core's screw-shaped portion and the roller assembly.

15 In order to avoid the foregoing drawbacks, the method of the invention is in turn characterized in that, for the purpose of advancing along and finally removing a formed portion of the pipe section from the core off its clear end, both the outer surfaces and the inner surfaces of the pipe section preform are subjected to rotational motions by using a core, at least a portion of which is screw-shaped, and
20 a roller assembly as described above, which surrounds at least a part of the core. The roller assembly has its rollers extending lengthwise of the core along the core preferably from the head of the core (i.e. from the beginning of the screw portion) all the way to the curing section.

25 Various rotation speeds of the components, i.e. the core and the rollers of the roller assembly, can be used to affect the insulation thickness, as well as the density of pipe sections. Being adjustable, the rollers thereby enable providing various insulation thicknesses (wall thickness in a pipe section) for pipe sections. In addition, the feeding angle of the mat can be adjusted, thereby also making a
30 difference in insulation thickness and density.

By way of this invention it is hence provided an apparatus for the continuous manufacture of insulating pipe sections, which apparatus is structurally much simpler than the prior art, more reliable and better in terms of density control, as
35 well as less bulky since there is no need for an external drawing device for the pipe

section preform. In addition, by using microwave irradiation as a curing method, the apparatus can be made even more simple and reliable. Even though continuous fabrication of a pipe section for insulating purposes was to a certain extent known as early as in the 1960's, we have not gained any knowledge about anyone having
5 thought of replacing a drawing device with a core which is screw-shaped.

Preferred embodiments of the invention are characterized by what is presented in the subsequent dependent claims.

10 The invention will now be described more specifically by way of example with reference to the accompanying drawings, in which:

fig. 1 shows an embodiment of an apparatus according to the invention,
and

15

fig. 2 shows an embodiment of an outer roller assembly according to the invention.

The apparatus shown in fig. 1 is capable of providing a uniform density of raw
20 material, a nonstop feeding K of a pipe section, and a low consumption of raw material. The apparatus comprises a screw 1, an outer roller assembly 2, a curing 3, and a straight cutting off 4 of a moving piece 5. A stone wool mat 6 is supplied in a feeding direction S from a single point onto the periphery of the screw 1, and the piece 5 is provided with a desired configuration by the outer roller assembly 2 which
25 comprises at least two, in this case 14 (see fig. 2) rollers 7 in alignment with the screw 1 or at angle of deviation relative to the screw. The mineral wool mat 6 has its feeding angle relative to the screw 1 preferably at 45-90°. The inner diameter of the piece 5 is defined by the screw's 1 outer diameter. The piece 5 advances in direction K in response to rotational motions of the screw 1 and the outer roller
30 assembly's 2 rollers 7. The screw portion 1 extends lengthwise of the core from the core head half-way along and the rollers 7 extend from the beginning of the core all the way to the curing section 3. Both the outer roller assembly's 2 rollers 7 and the screw 1 (i.e. the core) are motor-driven. The motor-drive feature is not depicted in the figures.

35

Fig. 2 shows one solution for an outer roller assembly according to the invention, which includes 14 rollers 7 arranged around a core in a close proximity of each other for producing an insulating layer as high grade and uniform as possible.

- 5 The insulating piece 5 formed in fig. 1 is subjected to curing preferably by microwave irradiation.

The solution described in this example should not be interpreted in a manner that would limit the invention presented in the claims.

Claims

1. An apparatus for the continuous manufacture of a mineral wool pipe section for insulating purposes, said apparatus comprising a core and an outer roller assembly surrounding it at least partially, said roller assembly including at least two rollers, whereby a mineral wool mat of designated length between the core and the roller assembly is windable around the core for forming a pipe section preform, one end of the core being clear for removing a formed pipe section from the core, as well as curing elements for curing the pipe section preform prior to a removal from the core off the core's clear end, **characterized** in that at least a portion of the core is screw-shaped, the advancement of a formed portion of the pipe section along the core and finally off the core taking place in response to rotational motions of both the core's screw-shaped portion and the roller assembly.
2. An apparatus as set forth in claim 1, **characterized** in that curing is arranged to be performed by heating or by means of microwaves.
3. An apparatus as set forth in claim 1 or 2, **characterized** in that the apparatus comprises one or more rollers in alignment with the screw or at an angle of deviation relative to the screw.
4. An apparatus as set forth in any of claims 1-3, **characterized** in that it comprises crosswise cutting means and/or lengthwise splitting and/or cutting means.
5. An apparatus as set forth in any of claims 1-4, **characterized** in that it is provided with one or more mat feed openings for feeding a mat around the core.
6. An apparatus as set forth in any of claims 1-5, **characterized** in that the mineral wool consists of stone wool.
7. A method for the continuous forming of a mineral wool pipe section for insulating purposes, comprising

- feeding a mineral wool mat around a core, which is clear at one of its ends, in such a manner that the subsequent mat lap at least partially overlaps the preceding mat lap
 - compressing the mineral mat fed around the core against the core by means of an outer roller assembly consisting of at least two rollers for producing a pipe section preform
 - curing the formed pipe section preform,
characterized in that, for the purpose of advancing a formed portion of the pipe section and finally removing it from the core off the core's clear end, both the outer surfaces and the inner surfaces of the pipe section preform are subjected to rotational motions by using a core, at least a portion of which is screw-shaped, and a roller assembly as mentioned above, which surrounds at least a part of the core.
8. A method as set forth in claim 7, **characterized** in that the formed pipe section preform is cured by means of hot air and/or microwaves.
9. A method as set forth in claim 8, **characterized** in that each roller of the apparatus is in alignment with or at an angle of deviation relative to the screw.
10. A method as set forth in any of claims 7-9, **characterized** in that the pipe section preform is cut off after its curing.
11. A method as set forth in any of claims 7-10, **characterized** in that after being cured, the pipe section preform is split in lengthwise direction and/or is provided with a lengthwise internal slit.
12. A method as set forth in claim 11, **characterized** in that the pipe section is coated.
13. A pipe section for insulating purposes manufactured by means of an apparatus as set forth in any of claims 1-6.
14. A pipe section for insulating purposes manufactured by means of a method as set forth in any of claims 7-12.

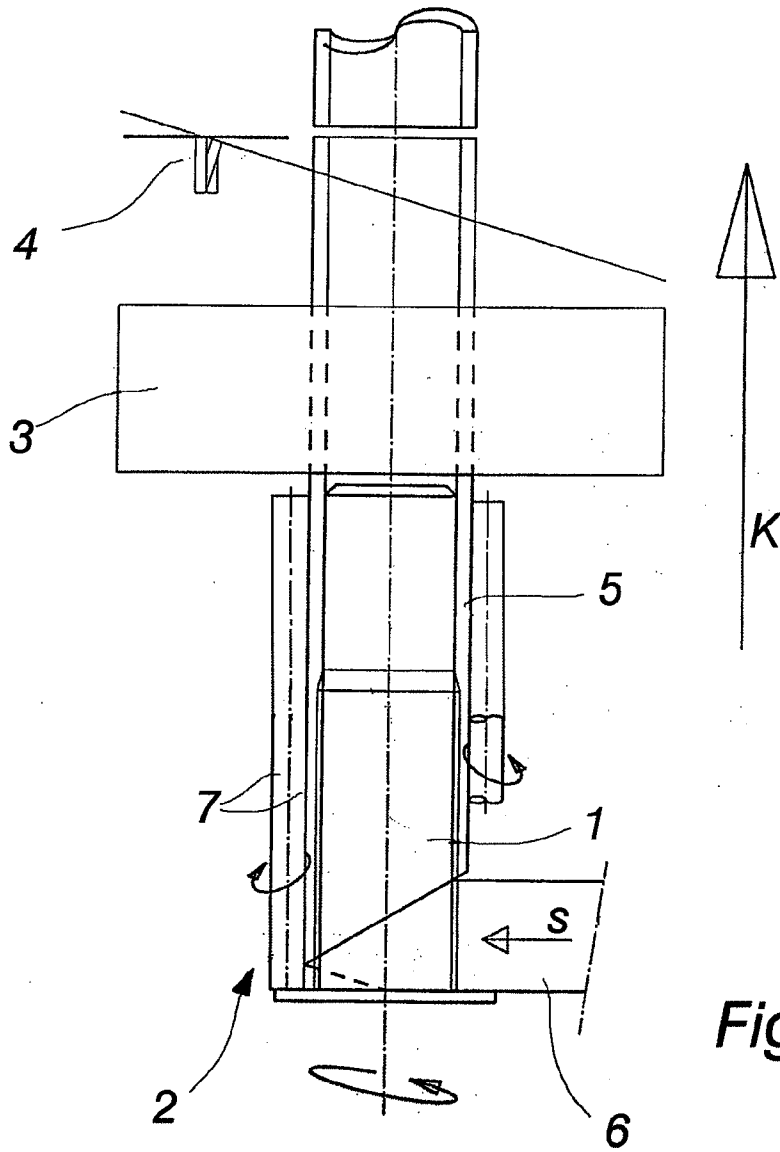

Fig. 1

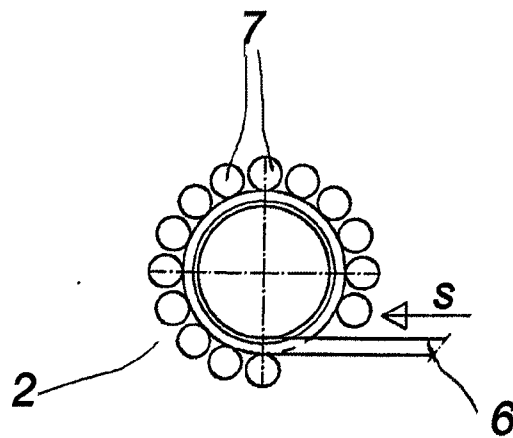

Fig. 2

INTERNATIONAL SEARCH REPORT

International application No
PCT/FI2006/050358

A. CLASSIFICATION OF SUBJECT MATTER INV. B29C53/60		
According to International Patent Classification (IPC) or to both national classification and IPC		
B. FIELDS SEARCHED		
Minimum documentation searched (classification system followed by classification symbols) B29C F16L		
Documentation searched other than minimum documentation to the extent that such documents are included in the fields searched		
Electronic data base consulted during the international search (name of data base and, where practical, search terms used) EPO-Internal		
C. DOCUMENTS CONSIDERED TO BE RELEVANT		
Category*	Citation of document, with indication, where appropriate, of the relevant passages	Relevant to claim No.
A	JP 61 202828 A (NIPPON SHEET GLASS CO LTD) 8 September 1986 (1986-09-08) abstract; figure 1 -----	1-14
A	JP 59 087130 A (NIPPON SHEET GLASS CO LTD) 19 May 1984 (1984-05-19) abstract; figure 1 -----	1-14
A	US 3 498 862 A (COMASTRI MAURO ET AL) 3 March 1970 (1970-03-03) cited in the application claim 1; figures 1-3 -----	1-14
<input type="checkbox"/> Further documents are listed in the continuation of Box C.		
<input checked="" type="checkbox"/> See patent family annex.		
* Special categories of cited documents :		
A document defining the general state of the art which is not considered to be of particular relevance *E* earlier document but published on or after the international filing date *L* document which may throw doubts on priority claim(s) or which is cited to establish the publication date of another citation or other special reason (as specified) *O* document referring to an oral disclosure, use, exhibition or other means *P* document published prior to the international filing date but later than the priority date claimed		
T later document published after the international filing date or priority date and not in conflict with the application but cited to understand the principle or theory underlying the invention *X* document of particular relevance; the claimed invention cannot be considered novel or cannot be considered to involve an inventive step when the document is taken alone *Y* document of particular relevance; the claimed invention cannot be considered to involve an inventive step when the document is combined with one or more other such documents, such combination being obvious to a person skilled in the art. *&* document member of the same patent family		
Date of the actual completion of the international search 18 January 2007	Date of mailing of the international search report 26/01/2007	
Name and mailing address of the ISA/ European Patent Office, P.B. 5818 Patentlaan 2 NL - 2280 HV Rijswijk Tel. (+31-70) 340-2040, Tx. 31 651 epo nl, Fax: (+31-70) 340-3016	Authorized officer Dupuis, Jean-Luc	

INTERNATIONAL SEARCH REPORT

Information on patent family members

International application No PCT/FI2006/050358

Patent document cited in search report	A	Publication date	Patent family member(s)	Publication date
JP 61202828	A	08-09-1986	JP 1741221 C JP 4028219 B	15-03-1993 13-05-1992
JP 59087130	A	19-05-1984	JP 1506809 C JP 63056056 B	13-07-1989 07-11-1988
US 3498862	A	03-03-1970	BE 686436 A DE 1660022 A1 DK 121285 B FI 50898 B GB 1114657 A IL 26368 A NL 6612638 A NO 123844 B	06-03-1967 27-05-1971 27-09-1971 30-04-1976 22-05-1968 19-02-1970 09-03-1967 24-01-1972