

J. ROOT.
Bolt Heading Machine.

No. 70,363.

Patented Oct. 29, 1867.

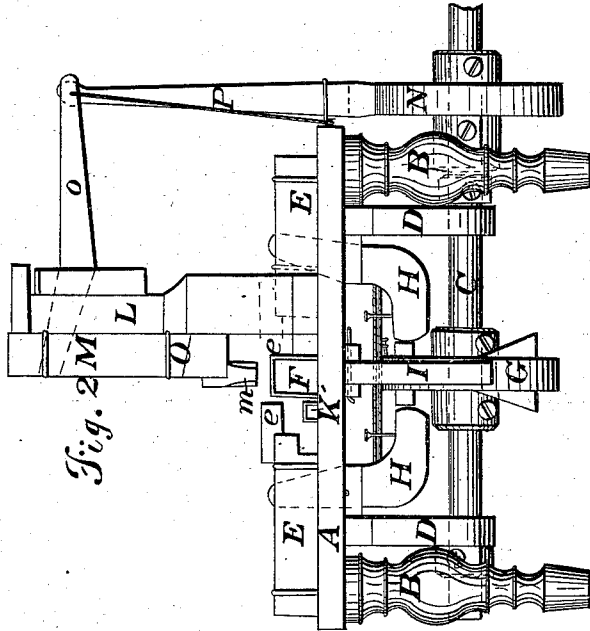

Fig. 2

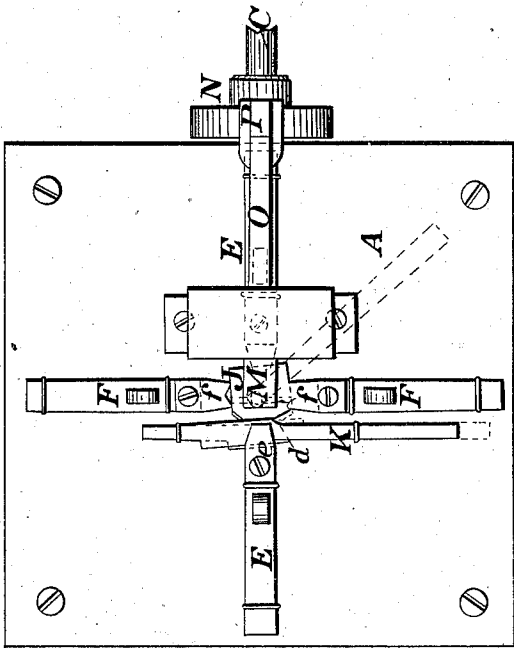

Fig. 1

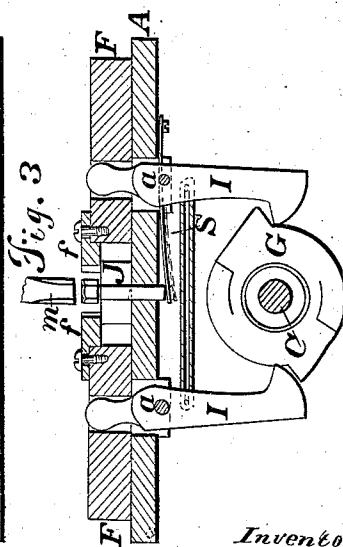

Fig. 3

Witnesses:
John H. Ramsey
W. J. Abbott

Inventor:
John Root
By his Attorney
John C. Carle

United States Patent Office.

JOHN ROOT, OF NEW HAVEN, CONNECTICUT, ASSIGNOR TO HIMSELF AND
McLAZAN AND STEVENS, OF THE SAME PLACE.

Letters Patent No. 70,363, dated October 29, 1867.

IMPROVED MACHINE FOR HEADING BOLTS.

The Schedule referred to in these Letters Patent and making part of the same.

TO ALL WHOM IT MAY CONCERN:

Be it known that I, JOHN ROOT, of New Haven, in the county of New Haven, and State of Connecticut, have invented a new Improvement in Bolt-Heading Machines; and I do hereby declare the following, when taken in connection with the accompanying drawings, and the letters of reference marked thereon, to be a full, clear, and exact description of the same, and which said drawings constitute part of this specification, and represent, in—

Figure 1, a top view,

Figure 2 a side view, and in

Figure 3 a vertical central section of the operative parts of the machine.

This invention relates to an improvement in machines for forging the heads of bolts, and consists in the peculiar arrangement and operation of the several dies with the mechanism combined therewith, so as to raise the bolt during the operation of heading, so that the head may be formed without the usual burr produced in other heading machines.

In order to the clear understanding of my invention, as well as to enable others to construct the same, I will proceed to a description thereof, as illustrated in the accompanying drawings.

A is the bed-plate, upon which the mechanism is placed, and is supported upon legs B, or otherwise. C is a driving-shaft, supported in bearings D beneath the bed-plate, and caused to revolve by the application of power thereto, in any convenient manner. EE and FF are four die-holders, arranged to slide to and from a common centre by the operation of a cam, G, upon the shaft, acting upon levers H H and I I, as seen in figs. 2 and 3, which said levers are pivoted to the bed-plate at *a*, and extend up through, so that their upper ends move their respective slides to and from the centre. Each of the said die-carriers is provided with dies *e e* and *f f*. In the centre of the machine, that is to say in a centre common to the four dies, is arranged a holding-die, J. The said holding-die J is formed in two parts, one of which is firmly secured to the bed-plate, and the other part movable to and from the first part, as denoted in red, fig. 1. The die-holder has a die-seat, formed half in each part, to correspond to the size of and so as to grasp and hold firmly the rod or bolt to be headed. The said die is operated by a sliding bar, *k*, arranged to move upon the bed-plate, as denoted in red in said fig. 1, and upon the inside of the said bar is an incline, *d*, which bears against the loose part of the holding-die, so that when the bar *k* is drawn out, as denoted in red, the holding-die will be opened, and when again the bar *k* is moved in, to the position denoted in black, the incline *d* will close the die. Therefore, when the die is open, and the bolt to be headed inserted therein, and the bar *k* moved inward to close the die upon the bolt, it will be firmly held within the die. In an upright supporting frame, L, is arranged another die-carrier, M, operated to move vertically by a cam, N, on the shaft C through a lever, O, and connecting-rod P, and the said die-holder has attached to it a vertical die, which is arranged centrally over the holding-die J, as seen in figs. 2 and 3, the under surface of the said die being formed to correspond to the shape of the surface of the head required to be formed. Beneath the bed-plate, and as seen in fig. 3, is arranged a spring, S, denoted in blue, fig. 1, so that the bolt, when inserted through the holding-die, will rest upon the said spring, as denoted in fig. 3, the tendency of the said spring being to force the bolt upward.

The operation of the machine is as follows: The bolt is first placed and grasped in the die-holder J, its lower end resting upon the spring S, the shaft C then caused to perform one revolution, in which the die *m* first strikes upon and upsets the metal, then either two of the dies *e e* and *f f* in their turns come forward and compress the head into the form corresponding to the form of the said dies. The upsetting-die *m* is brought a second time down on to the head, and raised therefrom. This necessarily and unavoidably leaves more or less of a burr around the lower end of the head. To avoid this, when the several dies have performed one operation, the holding-die is opened and the spring S forces the bolt up, as denoted in red, in which position the dies *e e* and *f f* are again forced up against the head, and the under surface of the head being so far raised above the holding-die, the said dies *e e* and *f f* strike and compress the burr into the head. Then the die *m* comes down again upon the head, driving it hard down upon the holding-die, and so on, continuing the operation until the perfect head is formed.

It may be here observed that the design of this machine is to produce bolts as an article of manufacture. These are formed of a certain specified length, so that the consumer may weld the headed blank upon a rod to produce the bolt of the length required; therefore the spring S requires no adjustment, as might at first appear from making bolts of different lengths.

I do not wish to be understood as broadly claiming four forging-dies, combined with an upsetting-die, for the purpose of forging bolt-heads, but what I do claim, and desire to secure by Letters Patent, is—

The arrangement of the forging-dies *e e* and *f f*, the upsetting-die *m*, and the holding-die *J*, in combination with the mechanism for operating the same, and the spring *S*, all constructed so as to operate substantially in the manner herein set forth.

JOHN ROOT.

Witnesses:

JOHN E. EARLE,

JOHN H. SHUMWAY.