

(12) INTERNATIONAL APPLICATION PUBLISHED UNDER THE PATENT COOPERATION TREATY (PCT)

(19) World Intellectual Property Organization  
International Bureau



(43) International Publication Date  
4 November 2010 (04.11.2010)

PCT

(10) International Publication Number  
**WO 2010/124348 A1**

- (51) **International Patent Classification:**  
*E04B 1/58* (2006.01)      *E04C 3/38* (2006.01)  
*E04B 1/24* (2006.01)
- (21) **International Application Number:**  
PCT/AU2010/000516
- (22) **International Filing Date:**  
4 May 2010 (04.05.2010)
- (25) **Filing Language:** English
- (26) **Publication Language:** English
- (30) **Priority Data:**  
2009901930      1 May 2009 (01.05.2009)      AU
- (71) **Applicant (for all designated States except US):**  
**MACROTEC HOLDINGS PTY LTD** [AU/AU]; Suite 1503, Level 5, 56 Scarborough Street, Southport, Queensland 4215 (AU).
- (72) **Inventor; and**
- (75) **Inventor/Applicant (for US only):** **MONTESALVO, John** [AU/AU]; Suite 1503, Level 5, 56 Scarborough Street, Southport, Queensland 4215 (AU).
- (74) **Agent:** **CULLENS**; Level 32, 239 George Street, Brisbane, Queensland 4000 (AU).
- (81) **Designated States (unless otherwise indicated, for every kind of national protection available):** AE, AG, AL, AM, AO, AT, AU, AZ, BA, BB, BG, BH, BR, BW, BY, BZ, CA, CH, CL, CN, CO, CR, CU, CZ, DE, DK, DM, DO, DZ, EC, EE, EG, ES, FI, GB, GD, GE, GH, GM, GT, HN, HR, HU, ID, IL, IN, IS, JP, KE, KG, KM, KN, KP, KR, KZ, LA, LC, LK, LR, LS, LT, LU, LY, MA, MD, ME, MG, MK, MN, MW, MX, MY, MZ, NA, NG, NI, NO, NZ, OM, PE, PG, PH, PL, PT, RO, RS, RU, SC, SD, SE, SG, SK, SL, SM, ST, SV, SY, TH, TJ, TM, TN, TR, TT, TZ, UA, UG, US, UZ, VC, VN, ZA, ZM, ZW.
- (84) **Designated States (unless otherwise indicated, for every kind of regional protection available):** ARIPO (BW, GH, GM, KE, LR, LS, MW, MZ, NA, SD, SL, SZ, TZ, UG, ZM, ZW), Eurasian (AM, AZ, BY, KG, KZ, MD, RU, TJ, TM), European (AL, AT, BE, BG, CH, CY, CZ, DE, DK, EE, ES, FI, FR, GB, GR, HR, HU, IE, IS, IT, LT, LU, LV, MC, MK, MT, NL, NO, PL, PT, RO, SE, SI, SK, SM, TR), OAPI (BF, BJ, CF, CG, CI, CM, GA, GN, GQ, GW, ML, MR, NE, SN, TD, TG).
- Published:**
- with international search report (Art. 21(3))
  - with amended claims (Art. 19(1))

WO 2010/124348 A1

(54) **Title:** CONSTRUCTION ELEMENT

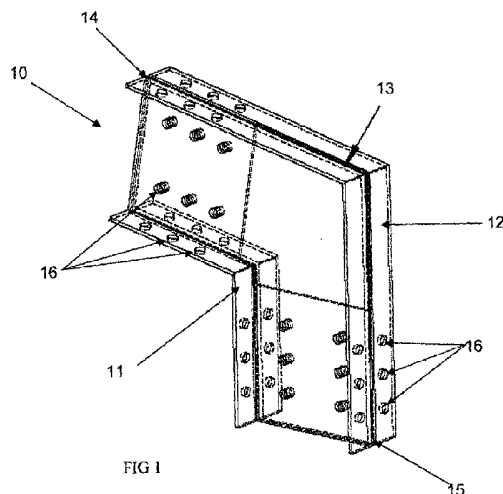

(57) **Abstract:** A construction element comprising a first connection portion adapted for connection to a first side of one or more beams, a second connection portion adapted for connection to a second side of the one or more beams, and an intermediate portion located between the first and second connection portions, wherein the first and second connection portions and the intermediate portion define a first beam-receiving portion at a first end of the construction element into which at least a portion of a first beam is inserted and retained and a second beam-receiving portion at a second end of the construction element into which at least a portion of a second beam is inserted and retained.

## **Construction Element**

### **Field of the Invention.**

The present invention relates to a construction element. In particular, the present invention relates to a construction element for the joining and support of beams (and particularly I-beams) during construction of a building.

### **Background Art.**

Beams, and in particular steel beams such as I-beams, are commonly used in the construction of buildings and other structures due to their structural properties and ability to withstand bending and shear forces.

Typically, I-beams are connected to one another or to other structural elements by welding plates to one of the I-beam or the structural element and subsequently drilling the other of the two to create a bolted connection using bolts or similar fasteners in order to secure the I-beams to one another or to the other structural element.

While widely used, this conventional method requires I-beams to be taken to a suitable location (such as a manufacturing plant) to be cut and drilled at the appropriate points and for the opposing member to have a connecting plate welded to it. This is time consuming and requires a considerable investment in plant equipment and labour.

Thus, there would be an advantage if it were possible to provide a construction element that allowed for the quick and simple attachment of an I-beam to an adjacent structural element without requiring the additional time and costs involved in preparing the I-beam for connection in a manufacturing plant.

It will be clearly understood that, if a prior art publication is referred to herein, this reference does not constitute an admission that the publication forms part of the common general knowledge in the art in Australia or in any other country.

Throughout this specification, the term “comprising” and its grammatical equivalents

shall be taken to have an inclusive meaning unless the context of use indicates otherwise.

#### **Object of the Invention.**

- 5 It is an object of the present invention to provide a construction element which may overcome at least some of the abovementioned disadvantages, or provide a useful or commercial choice.

10 In one aspect, the invention resides broadly in a construction element comprising a first connection portion adapted for connection to a first side of one or more beams, a second connection portion adapted for connection to a second side of the one or more beams, and an intermediate portion located between the first and second connection portions, wherein the first and second connection portions and the intermediate portion define a first beam-receiving portion at a first end of the construction element  
15 into which at least a portion of a first beam is inserted and retained and a second beam-receiving portion at a second end of the construction element into which at least a portion of a second beam is inserted and retained.

20 Preferably, the beams may be inserted into the beam-receiving portions until the beams abut the intermediate portion. The intermediate portion will normally be shaped. In particular, the intermediate portion will normally be provided with edges which in use, are adapted to abut portions of the beam located within the beam-receiving portion. Each edge will normally be shaped to positively locate the beam in the correct position and at the correct orientation by abutment of the beam with the  
25 edge. Indeed, each of the beam receiving portions and the connection portions which form them, will be configured such that use of the construction element will correctly locate and orient the beam for the construction.

30 The intermediate portion may be formed integrally with the first and second connection portions or may be formed separately from the first and second connection portions and subsequently connected thereto using any suitable technique, such as, but not limited to, welding, brazing, soldering or the like, or by using any suitable fastening means such as bolts, screws, rivets or the like, or any combination thereof.

In some embodiments of the invention, three or more beam-receiving portions may be provided.

5 In embodiments of the invention in which a plurality of beam-receiving portions are provided, the beam-receiving portions (or the connection portions) may be provided at any suitable angle to one another. For example, the first and second connection portions may be provided at an angle of between 0° and 180° to one another. For instance, should it be desired to connect two beams at right-angles to one another, the  
10 two beam-receiving portions of the construction element may be provided at a 90° angle to one another, although a skilled addressee will understand that the beam-receiving portions may be provided at any angle to one another depending on the intended use of the construction element. Thus, it will be understood that the construction element could be used at any suitable position in a building such as the  
15 apex of a roof, at a point where a roof meets a wall, or at a point where a wall meets a floor.

The beam-receiving portions may be of any suitable form. However, in a preferred embodiment of the present invention, the beam-receiving portions comprise a recess,  
20 channel, groove, slot or the like into which at least a portion of the beam may be inserted. In embodiments of the invention in which the beam is an I-beam, it is preferred that the vertical member of the I-beam is inserted into the beam-receiving portions.

25 The first and second connection portions may be of any suitable size, shape or configuration. The first and second connection portions may be of the same size, shape and configuration as one another or they may differ from one another.

The first and second connection portions may be adapted for connection to the first  
30 and second sides of a beam, respectively, using any suitable technique. For instance, the first and second connection portions may be welded, soldered, brazed or the like, or fastening means such as bolts, screws, rivets, adhesives or the like (or any combination thereof) may be used.

In a preferred embodiment of the invention, fastening means are used to connect the construction element to the beam. In this embodiment of the invention, at least one (and preferably both) of the first and second connection portions are provided with  
5 one or more receiving portions adapted to receive one or more fastening means. Any suitable receiving portions may be used, although in a preferred embodiment of the invention, the one or more receiving portions may be apertures through which one or more fastening means may be passed. Preferably, the one or more receiving portions align with one or more corresponding receiving portions located in the beam such that  
10 one or more fastening means can pass through the receiving portions in both the construction element and the beam in order to secure one to the other.

The construction element may be connected to the beam at any suitable point. For instance, if the beam is an I-beam, the construction element may be adapted for  
15 connection to the vertical member of the beam, one or both of the horizontal members of the beam, or both the vertical member and one or both of the horizontal members of the beam.

In embodiments of the invention in which the construction element is adapted for  
20 connection to both the vertical member and one or both of the horizontal members of the beam, it is preferred that the first and connection portions are suitably shaped so as to facilitate connection of the connection portions to the vertical member and one or both of the horizontal members of the beam. Thus, in this embodiment of the invention, one or both of the first and second connection portions may be substantially  
25 C-shaped in cross-section. Preferably, both of the first and second connection portions are substantially C-shaped in cross-section.

In these embodiments of the invention, the connection portions may be adapted to abut the outer surface of the vertical member of the beam, the lower surface of the  
30 uppermost horizontal member, and the upper surface of the lowermost horizontal member.

The construction element may be fabricated using any suitable material. Preferably,

however, the construction element is fabricated from metal such as, but not limited to steel, aluminium, iron or the like. In some embodiments of the invention, a surface coating may be used to improve the aesthetic appeal and/or the service life of the construction element. The construction element may be fabricated using any suitable  
5 technique such as, but not limited to, extrusion, casting, forging, roll-forming or the like.

In another aspect, the invention resides broadly in a method for connecting I-beams, the method comprising the steps of:

- 10 (a) inserting an end of a first I-beam into a first beam-receiving portion located at a first end of a construction element until the end of the first I-beam abuts an intermediate portion of the construction element;
- (b) inserting an end of a second I-beam into a second beam-receiving portion located at a second end of a construction element until the end of the second I-  
15 beam abuts an intermediate portion of the construction element; and
- (c) connecting at least a first or second connection portion of the construction element to at least the first or second I-beams.

#### **Brief Description of the Drawings.**

20 An embodiment of the invention will be described with reference to the following drawings in which:

- Figure 1 illustrates a perspective view of a construction element according to an embodiment of the present invention;
- Figure 2 illustrates a perspective view of a construction element according to an  
25 alternative embodiment of the present invention;
- Figure 3 illustrates a view of a construction including construction elements according to embodiments of the present invention;
- Figure 3A illustrates a cross-sectional view of an I-beam taken through Section D-D of Figure 3;
- 30 Figure 4 illustrates a perspective view of a construction element according to an embodiment of the present invention; and
- Figure 5 illustrates a perspective view of a construction element according to an alternative embodiment of the present invention.

### Detailed Description of the Drawings.

It will be appreciated that the drawings have been provided for the purposes of illustrating preferred embodiments of the present invention and that the invention should not be considered to be limited solely to the features as shown in the drawings.

In Figures 1 and 2 there are shown construction elements 10, 10A according to embodiments of the present invention. The construction elements 10, 10A comprise a first connection portion 11 and a second connection portion 12 having an intermediate portion 13 located therebetween. The first connection portion 11, the second connection portion 12 and the intermediate portion 13 serve to define a first beam-receiving portion 14 at a first end of the construction elements 10, 10A and a second beam-receiving portion 15 at a second end of the construction elements 10, 10A. The first beam-receiving portion 14 and the second beam-receiving portion 15 are provided at differing angles to one another in order to allow (in the case of Figure 1) a roof beam (not shown) to be inserted into the first beam-receiving portion 14 and a wall beam (not shown) to be inserted into the second beam-receiving portion 15. In this way, the construction element 10 of Figure 1 may be used to connect wall and roof beams during the construction of a building.

Similarly, the construction element 10A of Figure 2 is adapted to connect two I-beams (not shown) at the apex of a roof.

Each of the first 11 and second 12 connection portions are substantially C-shaped in cross-section in order to allow the construction elements 10, 10A to be connected to either or both of the vertical and horizontal members of an I-beam (not shown).

Both the first 11 and second 12 connection portions are provided with receiving portions in the form of apertures 16 that align with corresponding apertures in the I-beams (not shown) and through which fastening means (not shown) such as bolts may be passed in order to connect the I-beams (not shown) to the construction elements 10, 10A.

In Figure 3 there is shown a building construction in which a number of I-beams 17 are connected to one another using construction elements 10, 10A according to embodiments of the present invention.

- 5 Construction elements 10 are shown connecting I-beams 17 that form a part of the walls of the building to I-beams 17 that form the roof of the building. On the other hand, construction element 10A is located at the apex of the roof and serves to provide a means of connecting the two roof I-beams together.
- 10 The wall I-beams 17 are retained in a vertical position by brackets 18 adapted to be secured to the floor or ground and the ends of the wall I-beams 17.

Figure 3A illustrates a cross-sectional view of an I-beam taken through section D-D of Figure 3.

- 15 In Figure 4, a construction element 10 is shown when in use. The vertical members 19 of two I-beams 17 are inserted into the first 14 and second 15 beam-receiving portions of the construction element 10 until the ends of the I-beams 17 abut the intermediate portion 13 of the construction element 10.

- 20 The first 11 and second 12 connection portions are provided with a plurality of apertures 16 which align with corresponding apertures 20 in both the vertical 19 and horizontal 21 members of the I-beams 17. Once the apertures 16 in the construction element 10 and the apertures 21 in the I-beams 17 are correctly aligned, fastening
- 25 means (not shown) may be passed through the aligned apertures 16, 20 in order to secure the I-beams 17 to the construction element 10.

- In Figure 5, a construction element 10A is shown when in use. The vertical members 19 of two I-beams 17 are inserted into the first 14 and second 15 beam-receiving
- 30 portions of the construction element 10A until the ends of the I-beams 17 abut the intermediate portion 13 of the construction element 10.

The first 11 and second 12 connection portions are provided with a plurality of

apertures 16 which align with corresponding apertures 20 in both the vertical 19 and horizontal 21 members of the I-beams 17. Once the apertures 16 in the construction element 10A and the apertures 21 in the I-beams 17 are correctly aligned, fastening means (not shown) may be passed through the aligned apertures 16, 20 in order to  
5 secure the I-beams 17 to the construction element 10A.

Those skilled in the art will appreciate that the present invention may be susceptible to variations and modifications other than those specifically described. It will be understood that the present invention encompasses all such variations and  
10 modifications that fall within its spirit and scope.

**Claims.**

1. A construction element comprising a first connection portion adapted for connection to a first side of one or more beams, a second connection portion adapted for connection to a second side of the one or more beams, and an intermediate portion located between the first and second connection portions, wherein the first and second connection portions and the intermediate portion define a first beam-receiving portion at a first end of the construction element into which at least a portion of a first beam is inserted and retained and a second beam-receiving portion at a second end of the construction element into which at least a portion of a second beam is inserted and retained.
2. A construction element according to claim 1 wherein the first and second beams are inserted into the respective beam-receiving portions until the first and second beams abut the intermediate portion.
3. A construction element according to claim 1 or claim 2 wherein the intermediate portion is provided with edges that in use are adapted to abut portions of the beam located within the beam-receiving portion.
4. A construction element according to claim 1 or claim 2 wherein the first and second beam-receiving portions are disposed at an angle of between 0° and 180° to one another.
5. A construction element according to any one of the preceding claims wherein one or more fastening means are used to connect the construction element to the beam.
6. A construction element according to claim 5 wherein the first and second connection portions are provided with one or more receiving portions adapted to receive the one or more fastening means.
7. A construction element according to claim 6 wherein the one or more receiving portions in the connection portions align with one or

more receiving portions in the beam to receive the one or more fastening means therethrough.

8. A construction element according to any one of the preceding claims wherein at least one of the connection portions is substantially C-shaped in cross-section.
9. A construction element according to any one of the preceding claims wherein at least one of the beams comprises an I-beam.
10. A construction element according to claim 9 wherein the construction element is adapted for attachment to a vertical member of the I-beam, one or both horizontal members of the I-beam or both the vertical and one or both of the horizontal members of the I-beam.
11. A method for connecting I-beams, the method comprising the steps of:
- (a) inserting an end of a first I-beam into a first beam-receiving portion located at a first end of a construction element until the end of the first I-beam abuts an intermediate portion of the construction element;
  - (b) inserting an end of a second I-beam into a second beam-receiving portion located at a second end of a construction element until the end of the second I-beam abuts an intermediate portion of the construction element; and
  - (c) connecting at least a first or second connection portion of the construction element to at least the first or second I-beams.

**AMENDED CLAIMS**  
received by the International Bureau on 31 August 2010 (31.08.10).

1. A construction element comprising a first connection portion adapted for connection to a first side of one or more beams, a second connection portion adapted for connection to a second side of the one or more beams, each of the connecting portions having a pair of spaced apart C-section flanges with an opening defined therebetween and an intermediate portion located between the first and second connection portions, wherein the first and second connection portions and the intermediate portion define a first beam-receiving portion at a first end of the construction element into which at least a portion of a first beam is inserted and retained and a second beam-receiving portion at a second end of the construction element into which at least a portion of a second beam is inserted and retained.
2. A construction element according to claim 1 wherein the first and second beams are inserted into the respective beam-receiving portions until the first and second beams abut the intermediate portion.
3. A construction element according to claim 1 or claim 2 wherein the intermediate portion is provided with edges that in use are adapted to abut portions of the beam located within the beam-receiving portion.
4. A construction element according the first and second beam-receiving portions are disposed at an angle of between  $0^{\circ}$  and  $180^{\circ}$  to one another.
5. A construction element according to any one of the preceding claims wherein one or more fastening means are used to connect the construction element to the beam
6. A construction element according to claim 5 wherein the first and second connection portions are provided with one or more receiving portions adapted to receive the one or more fastening means.
7. A construction element according to claim 6 wherein the one or more receiving portions in the connection portions align with one or more receiving portions in the beam to receive the one or more fastening means therethrough.
8. A construction element according to any one of the preceding claims wherein at least one of the connection portions is substantially C-shaped in cross-section.

9. A construction element according to any one of the preceding claims wherein at least one of the beams comprises an I-beam.
10. A construction element according to claim 9 wherein the construction element is adapted for attachment to a vertical member of the I-beam, one or both horizontal members of the I-beam or both the vertical and one or both of the horizontal members of the I-beam.
11. A method for connecting I-beams, the method comprising the steps of:
  - (a) inserting an end of a first I-beam into a first beam-receiving portion located at a first end of a construction element until the end of the first I-beam abuts an intermediate portion of the construction element;
  - (b) inserting an end of a second I-beam into a second beam-receiving portion located at a second end of a construction element until the end of the second I-beam abuts an intermediate portion of the construction element;  
and
  - (c) connecting at least a first or second connection portion of the construction element to at least the first or second I-beams.

1/3

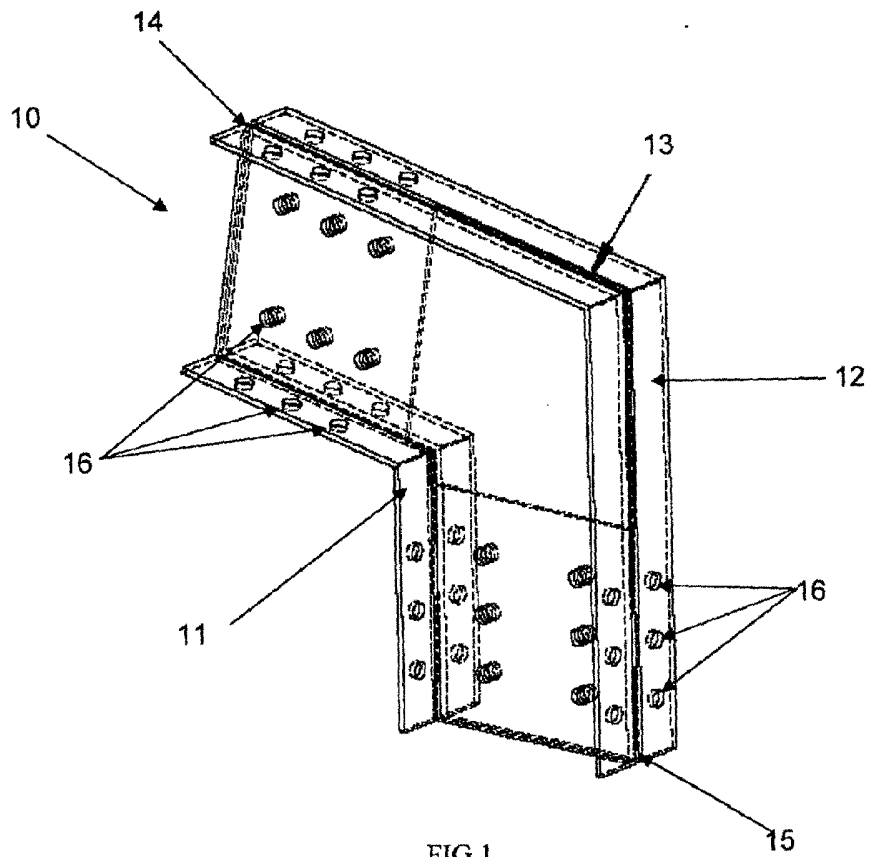

FIG 1

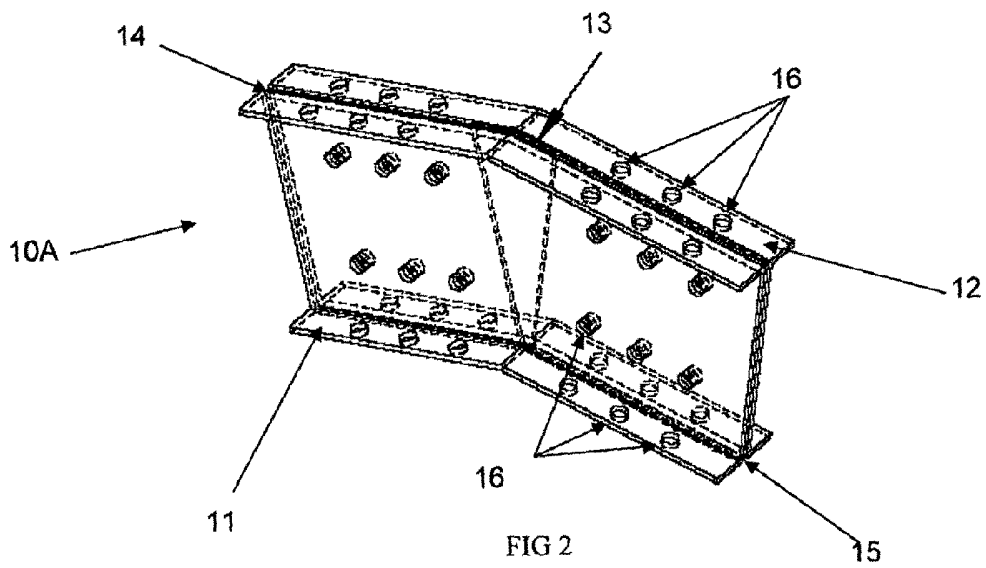

FIG 2

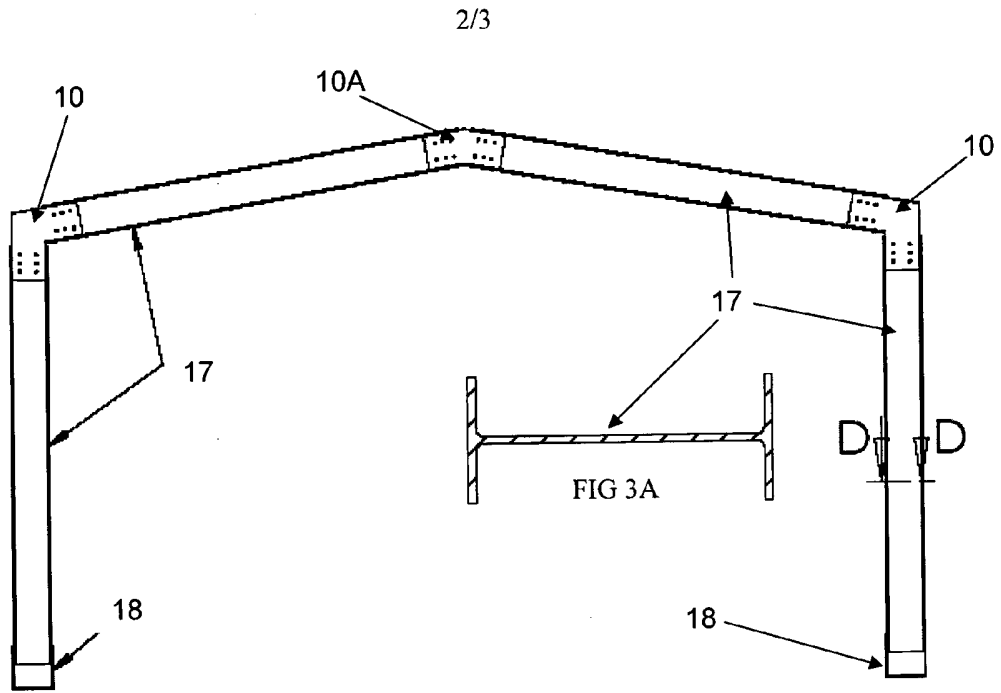

FIG 3

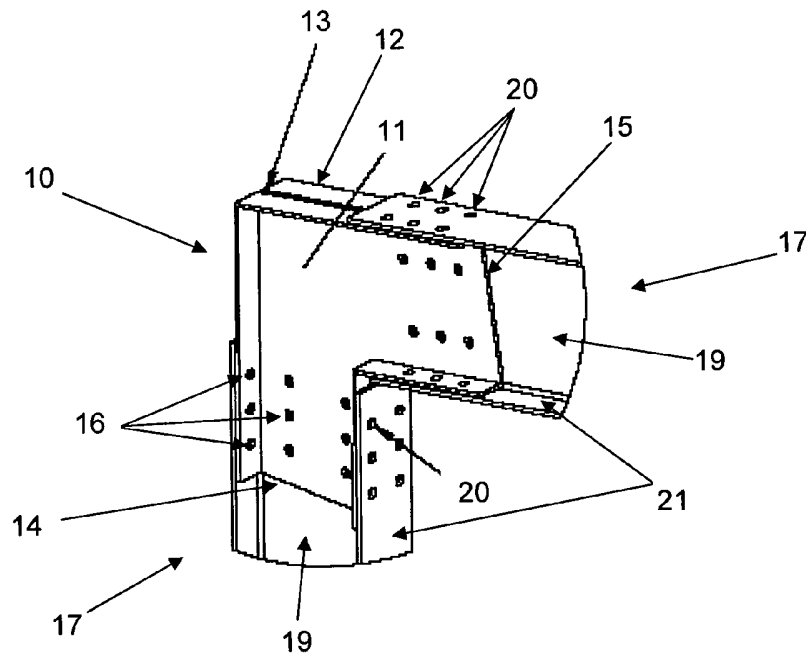

FIG 4

