

(No Model.)

3 Sheets—Sheet 1.

W. McL. LOTTRIDGE.
SURGICAL CHAIR.

No. 524,969.

Patented Aug. 21, 1894.

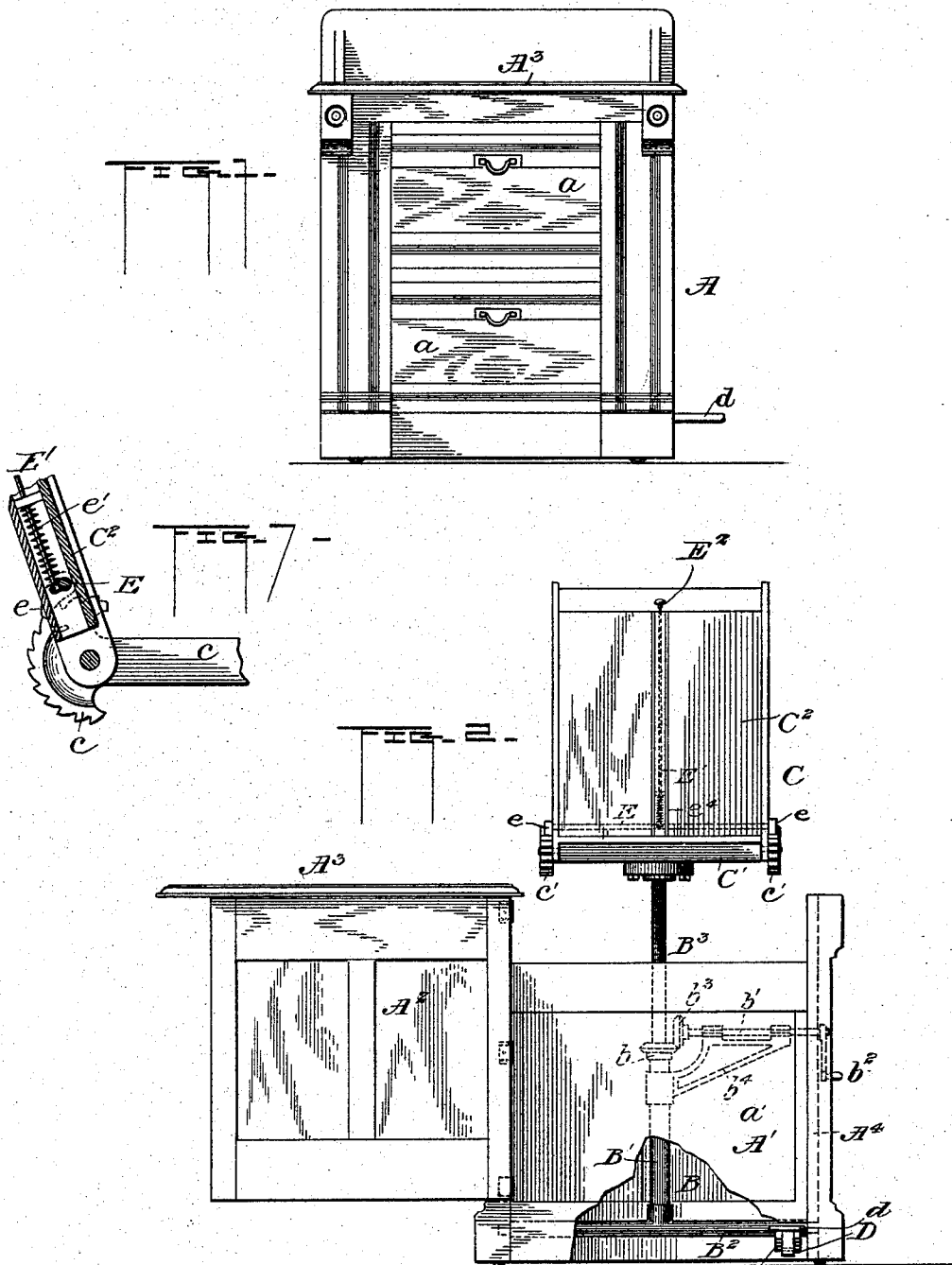

Witnesses

L. H. Cornum
Chas E. Boardman

B^2 Inventor

Wm McL Lottridge
By Rutledge & Powell
his Attorneys

(No Model.)

3 Sheets—Sheet 2.

W. McL. LOTTRIDGE.
SURGICAL CHAIR.

No. 524,969.

Patented Aug. 21, 1894.

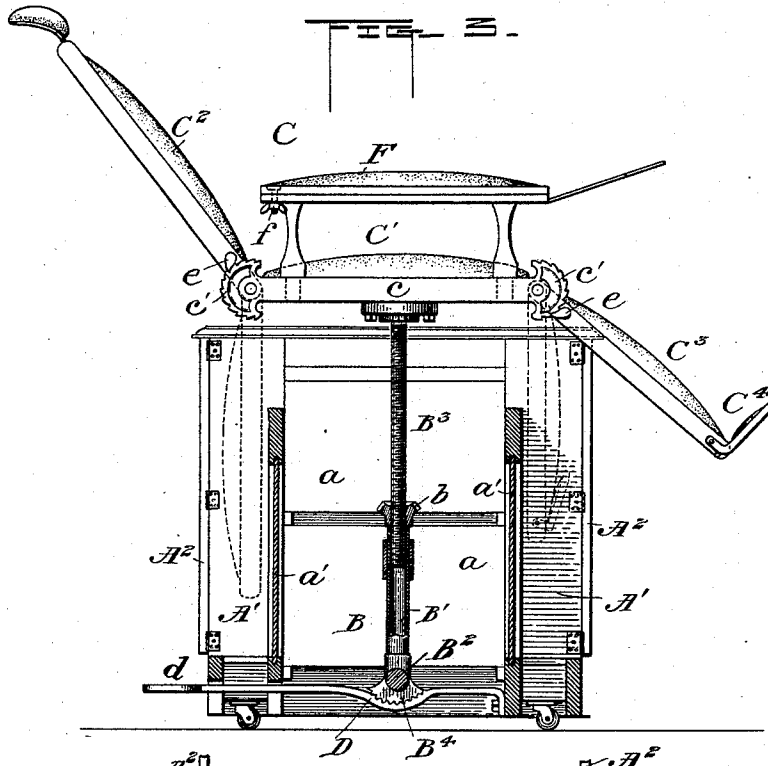
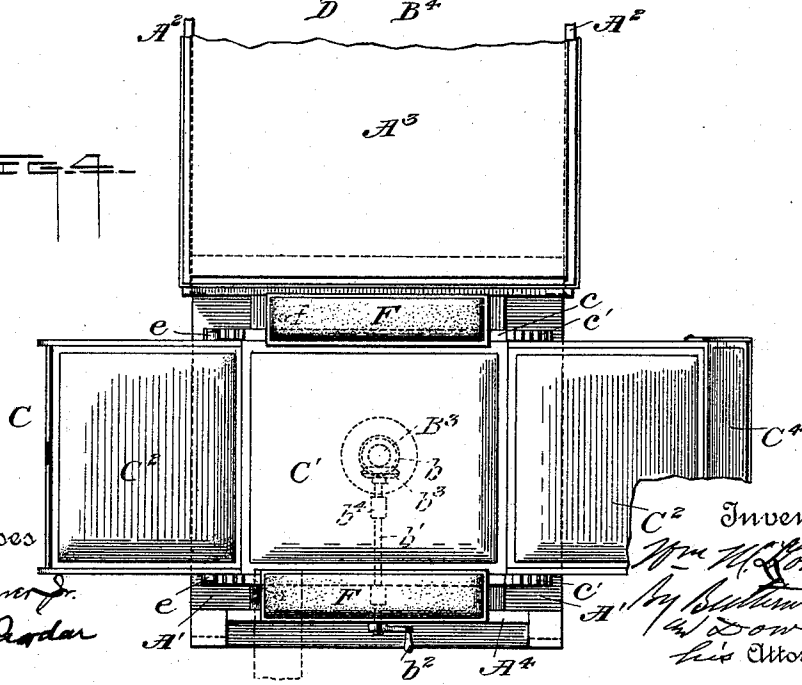

FIG. 4.



Witnesses
 L. H. Connor Jr.
 Chas. E. Rogers

C² Inventor
 Wm. M. Lottridge
 by
 J. S. Dowell
 his Attorney

(No Model.)

3 Sheets—Sheet 3.

W. McL. LOTTRIDGE.
SURGICAL CHAIR.

No. 524,969.

Patented Aug. 21, 1894.

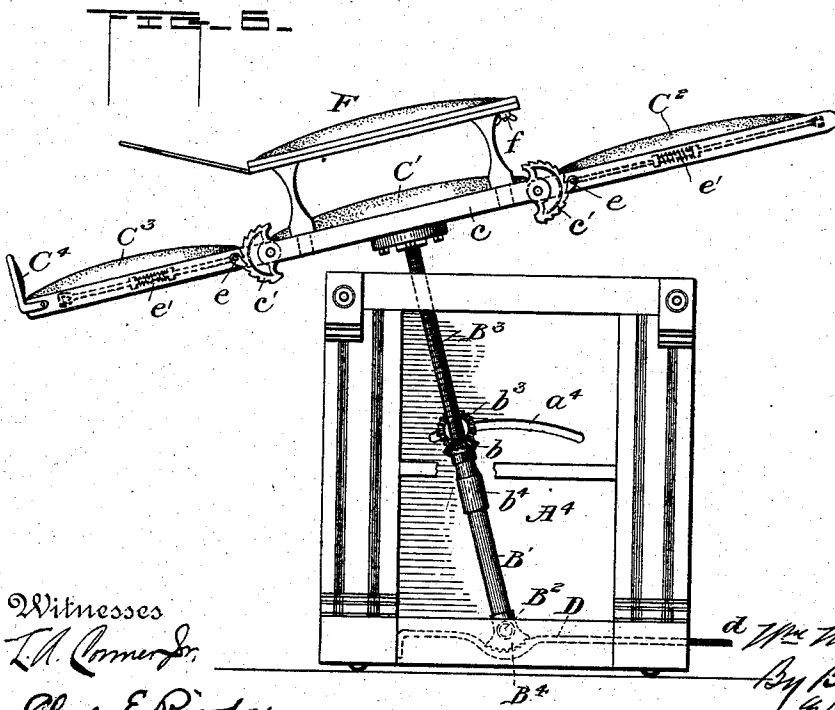
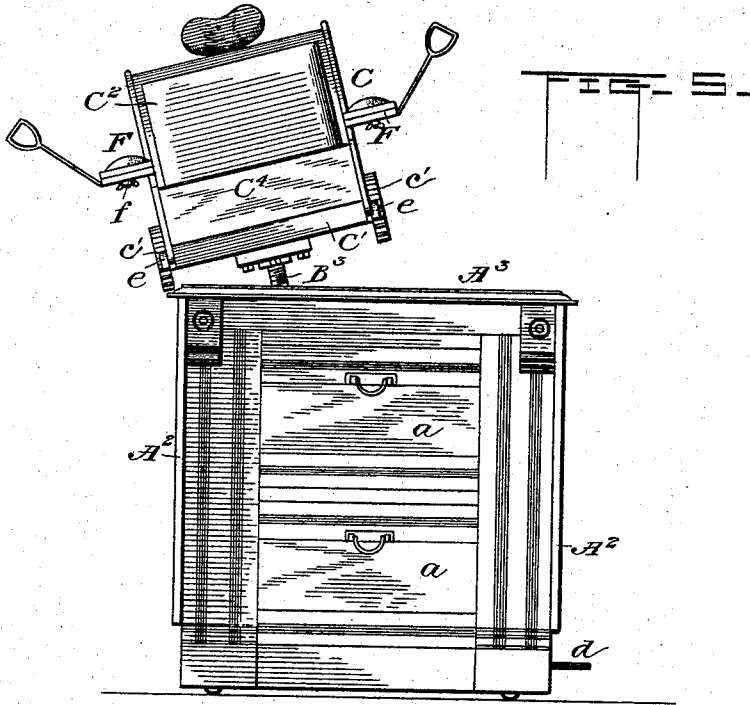

Witnesses
L. M. Combs Jr.
Chas. E. Riordan

Inventor
W. McL. Lottridge
By *Butterworth*
W. Dowell
his Attorney

UNITED STATES PATENT OFFICE.

WILLIAM McLELLAND LOTTRIDGE, OF PORTSMOUTH, OHIO, ASSIGNOR OF
ONE-HALF TO JOHN F. STRAYER, OF SAME PLACE.

SURGICAL CHAIR.

SPECIFICATION forming part of Letters Patent No. 524,969, dated August 21, 1894.

Application filed July 19, 1893. Serial No. 480,947. (No model.)

To all whom it may concern:

Be it known that I, WILLIAM McLELLAND LOTTRIDGE, a citizen of the United States, residing at Portsmouth, in the county of Scioto and State of Ohio, have invented certain new and useful Improvements in Surgical Chairs; and I do hereby declare the following to be a full, clear, and exact description of the invention, such as will enable others skilled in the art to which it appertains to make and use the same.

My invention relates to surgical and dental appliances, but more particularly to surgical chairs, and the principal object is to provide a chair and cabinet inclosing the same combined with mechanism for raising and lowering the chair, whereby all the adjustments of the chair that may be required in performing surgical operations are secured and at the same time the chair is adapted to be inclosed so as not to be exposed to dust and the wear and tear incident to handling and exposure when not in use; the cabinet with the chair inclosed therein being adapted to give the appearance of an ordinary cabinet capable of ordinary uses.

A further object is to adapt the removable top to serve as a table adjacent to the chair upon which the patient is placed, so that the surgical or other instruments desired for use may be arranged thereon convenient to the surgeon or his assistant.

The invention will first be described with reference to the accompanying drawings, which form a part of this specification, and then pointed out in the claims at the end of the description.

Referring to the drawings, Figure 1 represents a front elevation of the cabinet having the surgical chair inclosed and concealed therein. Fig. 2 is a side elevation of the same showing the cabinet doors open and the movable top resting on said doors; the chair being shown in an elevated position. Fig. 3 is a view from the rear showing the cabinet and chair-elevating mechanism in section and the chair in side elevation. Fig. 4 is a plan of the same. Fig. 5 is a front view of the cabinet as shown in Fig. 1 with the chair elevated and inclined into what is known as "Syms position." Fig. 6 is a front view of the cabinet with the drawers and doors re-

moved, showing the chair elevated and inclined to what is known as the "chloroform position;" and Fig. 7 is a detail section of the ratchet and pawl operating mechanism for adjusting the back and leg sections of the chair.

Similar letters of reference are used to denote similar parts in each of the several views. A, in the drawings, denotes a cabinet of wood or other suitable material having side compartments or pockets A', and doors A², for closing said compartments. These doors are adapted to swing around to about one hundred and eighty degrees so as to stand perpendicular to the face of the cabinet in proper position to support the top A³, the latter being movable and preferably adapted to be slid onto the said doors so as to serve as a table adjacent to the chair when the latter is elevated in position for use. The cabinet may be further provided with drawers a, forming convenient receptacles for the tools or surgical instruments necessary to a surgical or dental operation. The partitions a', of the pockets, together with the back A⁴, of the cabinet, and the drawers a, thereof, form a compartment in which is placed the mechanism B, for elevating and lowering the chair C.

The elevating and lowering mechanism B, comprises preferably a sleeve B', supported on a rock-shaft B², and a screw-rod B³, which supports at its upper end the chair C. A nut b, fitted upon the screw-rod B³, is circumferentially toothed to engage a gear-wheel b², on the end of a horizontal shaft b', which latter is mounted in a bracket-arm b⁴, carried by the sleeve B'; the gear-wheel or nut b, is confined between the gear b², and the upper end of the sleeve B', and the shaft b', is provided with a handle b⁵, at its outer end. By this arrangement longitudinal movement of the screw-rod B³, is prevented, but the rotation of the nut b, causes the threaded rod to be advanced or retracted within the sleeve B', so as to accomplish the elevation or depression of the chair. The rock-shaft B², is provided with a curved or toothed segment B⁴, which is engaged by a toothed bar D, preferably of spring metal, having a foot pedal d, projecting outside of the cabinet to permit it to be depressed for the purpose of disengaging the toothed segment on the shaft B², so as to per-

mit the said shaft and sleeve B', together with the mechanism supported thereon to be rocked to either side of a perpendicular position for the purpose of securing the desired inclination of the chair. On releasing the foot pedal the toothed portion of the bar D, will engage the segment B⁴, so as to lock the shaft B³, and hold the seat supporting mechanism in the desired position.

The shaft b', may project through a curved slot a⁴, in the back A⁴, of the cabinet and the handle b², is secured to its outer end for the purpose of turning the shaft so as to rotate the nut b, and raise or lower the chair. This arrangement brings the pedal on the toothed bar D, and the handle b², within easy reach of the operator, for accomplishing the desired adjustment.

The chair C, in the present instance is designed especially for surgical operations, but of course a chair of a different construction may be supported upon the elevating mechanism and inclosed in the cabinet when not in use. The seat C', is mounted upon the upper end of the screw-rod B³, in such manner as to be rotatable thereon in a plane perpendicular to said rod. Said seat is provided with side plates or frames c, c, which may terminate in ratchet-faced segments c'. The back section C², and the leg section C³, may be hinged to the seat C', in any suitable manner. As shown the back and leg sections are hinged to the side plates c, c, and provision is made for adjusting such sections as will now be described. Upon the ends of a rod E, carried by the back and leg sections are placed pawls e, which are held normally in engagement with the respective segments c', of the plates c, c, by means of a spring e', which bears upon a projection on said rod, the spring being shown as surrounding a tripping rod E', which is adapted to be pulled by a handle E², so as to disengage the pawls against the action of the spring.

The foot rest C⁴, may be hinged to the lower end of the leg rest C³, and is adapted to be folded up against the said leg rest. A head rest of any suitable type may be used in connection with the back section C², if desired.

The arm rests F, are shown as removably secured to the side frames c, but it is obvious that they may be hinged thereto, and they are preferably divided or sectional, the two sections being pivoted together as at f, so that one section may be swung outward at an angle for use in amputating an arm or performing some other operation necessitating the swinging of the arm outward so as to make it more accessible to the surgeon; this adjustment of the section being accomplished by simply loosening the set screw f, adjusting the arm, and then tightening the screw so as to secure the section in the desired position.

The cabinet forms the chair base and is preferably provided with casters for convenience in moving the same about the room. Stirrups are provided for use particularly in

gynecological cases and may be readily removed and placed within the cabinet when not required for use.

From the foregoing description, a brief outline only of the manipulation of the chair and cabinet will be necessary. The cabinet being closed it will be seen, upon opening the doors at the side, that the back and leg sections are dropped downward so as to lie in such a position as to fit the space provided by the pockets or compartments. The seat portion of the chair rests within the space between the top of the cabinet and the upper portion of the partition walls a'. The foot rest is folded back upon the leg rest. The arm and head rests being removable, are conveniently stored by being placed upon the seat of the chair, or in any other suitable place within the cabinet.

When it is desired to use the chair, which by the foregoing arrangement has been protected from dust, soiling and unnecessary use, the doors of the cabinet may be opened, and the top thereof slid over so as to rest upon said doors and thereby form a table, and at the same time render the chair accessible. The operator will then turn the crank b², until the chair is elevated to a sufficient height; the back section and the leg section may then be raised to their proper positions, (which may be either a sitting or a reclining position) and the arm and head rests being properly placed, the chair is ready for use. The revolving of the chair in a plane perpendicular to the elevating screw rod and sleeve, and the oscillation of same upon the cross shaft B², makes a practically universal movement thereof possible, so that by this simple means the chair may be adjusted so as to place the patient in whatever position may be desired, as, for instance, the "Syms," as shown in Fig. 5, or the "chloroform" as shown in Fig. 6, or such other position as is best adapted to bring the parts to be operated upon or examined into the most advantageous position.

The manipulation of the chair is very simple—the ratchet adjustment of the back and leg sections being obvious. The chair in the position for operations is conveniently located to the table upon which the instruments are placed, so that the operator can easily reach them, and the drawers of the cabinet afford a convenient storage place for tools or surgical instruments and serve to keep them from view until they are desired for use. The closing of the cabinet and the folding of the chair therein involves simply a reversal of the operation which has just been described. When closed the cabinet may be made to present a very ornamental appearance, and may be utilized to advantage for various purposes.

The cabinet and elevating mechanism are so constructed that the chair may be detached if desired. The top is preferably plain as shown in Fig. 2, but may have a slab as shown in Fig. 1.

It is obvious that various modifications may be made in the arrangement and construction of parts without departing from the spirit of my invention, and hence I do not desire to be limited to the exact construction shown and described, for it is obvious that an ordinary rack bar might take the place of the elevating mechanism B, and be operated by a suitable lever or crank arm operating a pinion adapted to engage the rack bar, and any suitable locking device would hold the chair at the desired elevation. The hinged back and leg sections might also be adjusted and sustained in the desired position by knuckle braces, or levers and slides.

Having thus fully described my invention, what I claim as new, and desire to secure by Letters Patent of the United States, is—

1. A surgical appliance comprising the cabinet having the removable top with the chair-supporting and adjusting mechanism inclosed therein, and the chair rotatably mounted on said mechanism, the latter being adapted to raise and lower the chair and to sustain the same in an elevated position for use, and to be inclined to either side of the cabinet, whereby the chair may be raised and arranged in various inclined positions in use, or lowered and housed within the cabinet, substantially as described.

2. A surgical appliance comprising the cabinet having the movable top and hinged doors, together with the chair-supporting and elevating mechanism arranged within the cabinet and having the chair mounted thereon; said doors being adapted to swing partially around to provide a support for said top, whereby a table is provided adjacent to the chair when the latter is elevated in position for use, substantially as described.

3. In combination with a surgical chair composed of a seat and hinged back and leg sections, mechanism for raising and lowering the same, a cabinet having pockets adapted to receive said back and leg sections, a removable top, and doors adapted to close said pockets when shut, and to support said top when open, whereby a table is formed, substantially as described.

4. In combination with a surgical chair composed of a seat and hinged back and leg sections, mechanism adapted to raise and lower the same, said mechanism being capable of oscillation and said chair being capable of a gyratory movement, of a base for said chair consisting of a cabinet provided with pockets adapted to receive said back and leg sections, and doors adapted to close said pockets, said cabinet being adapted to inclose said chair when lowered, substantially as described.

5. In combination with a surgical chair composed of a seat and hinged back and leg sections, mechanism adapted to raise and lower the same, said mechanism being capable of oscillation and said chair being capable of a gyratory movement, means substan-

tially as described for locking said mechanism in the desired position, and a base for said chair consisting of a cabinet provided with pockets adapted to receive said back and leg sections and doors adapted to close said pockets; said cabinet being adapted to inclose said chair when lowered, substantially as described.

6. The combination with a surgical chair composed of a seat and hinged back and leg sections, of mechanism adapted to raise and lower the same, and a cabinet supporting said mechanism, the latter comprising a shaft journaled in said cabinet, a sleeve, a screw-rod, a nut engaging said screw-rod, and means for revolving said nut, whereby the chair is elevated and lowered; said raising and lowering mechanism being capable of oscillation and said chair being capable of a gyratory movement, substantially as described.

7. The combination with a surgical chair composed of a seat and hinged back and leg sections, of mechanism adapted to raise and lower the same, and a cabinet supporting said mechanism, the latter comprising a shaft journaled in said cabinet, a sleeve, a screw-rod, a nut engaging said screw-rod, and means for revolving said nut, whereby the chair is elevated and lowered; said raising and lowering mechanism being capable of oscillation and said chair being capable of a gyratory movement; and a device adapted to lock said elevating and lowering mechanism in the desired position, substantially as described.

8. The combination with a surgical chair composed of a seat and hinged back and leg sections, and mechanism adapted to raise and lower the same, of a cabinet supporting said mechanism; the latter comprising a shaft journaled in said cabinet, a sleeve projecting from the shaft, a screw-rod fitting at one end in said sleeve, a nut on said rod provided with gear teeth, a gear upon a horizontal shaft journaled in a bracket carried by said sleeve, and a handle whereby the shaft is rotated and said nut caused to rotate; said screw-rod having the chair mounted thereon to be elevated, substantially as described.

9. The combination with a surgical chair composed of a seat and hinged back and leg sections, of mechanism adapted to raise and lower the same, and a cabinet supporting and housing said mechanism, the latter comprising a screw-rod on which the chair is mounted, a nut rotatably held upon and engaging said screw-rod, and means extending from within the cabinet to the exterior thereof for revolving said nut, whereby the chair is elevated and lowered, substantially as described.

In testimony whereof I affix my signature in presence of two witnesses.

WILLIAM McLELLAND LOTTRIDGE.

Witnesses:

J. F. STRAYER,
JNO. D. WILHELM.