



(19) **United States**
(12) **Patent Application Publication**
Chan et al.

(10) **Pub. No.: US 2014/0040123 A1**
(43) **Pub. Date: Feb. 6, 2014**

(54) **METHODS AND APPARATUS FOR FUNDS REMITTANCES TO NON-PAYMENT CARD ACCOUNTS USING PAYMENT CARD SYSTEM**

Publication Classification

(51) **Int. Cl.**
G06Q 20/22 (2006.01)
(52) **U.S. Cl.**
CPC *G06Q 20/22* (2013.01)
USPC **705/39**

(71) Applicant: **MasterCard International Incorporated**, Purchase, NY (US)

(72) Inventors: **David Chan**, Singapore (SG); **Samuel Lim**, Singapore (SG); **Rama Sridhar**, Singapore (SG)

(73) Assignee: **MasterCard International Incorporated**, Purchase, NY (US)

(21) Appl. No.: **14/047,393**

(22) Filed: **Oct. 7, 2013**

Related U.S. Application Data

(63) Continuation of application No. 11/951,043, filed on Dec. 5, 2007, now abandoned.

(57) **ABSTRACT**

Apparatus and methods for funds remittances to non-payment card accounts are described. An embodiment includes a processor receiving a funds transfer request specifying a transaction amount, a destination bank account and a source account, and determining that the destination account is not a payment card account. The processor then initiates a payment transaction routed from the source account via a payment card system network to a payment card system settlement account that has been established in an agent bank in the same country as the destination bank account. The processor stores an instruction file of transfer instructions for the agent bank to transfer the transaction amount from the payment card system settlement account to the destination bank account, and later transmits the instruction file to the agent bank.

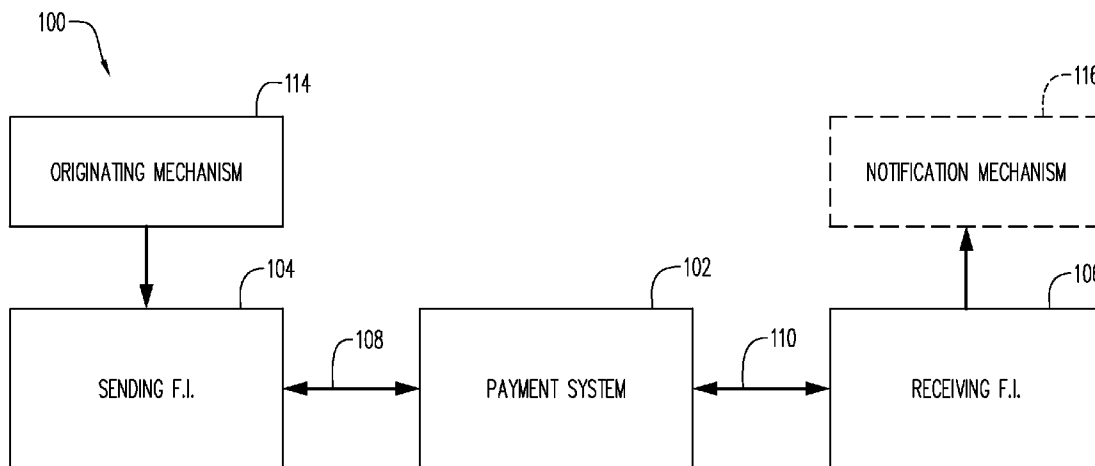

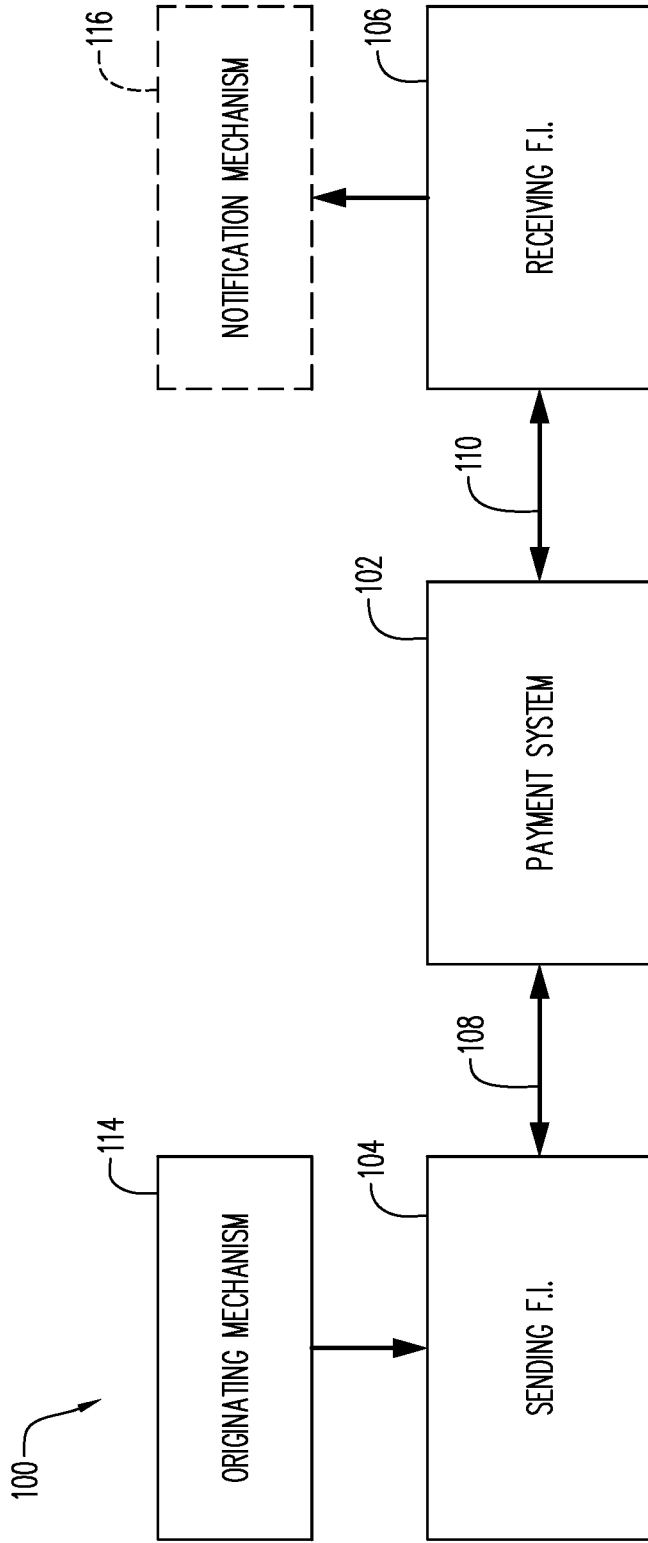

FIG. 1

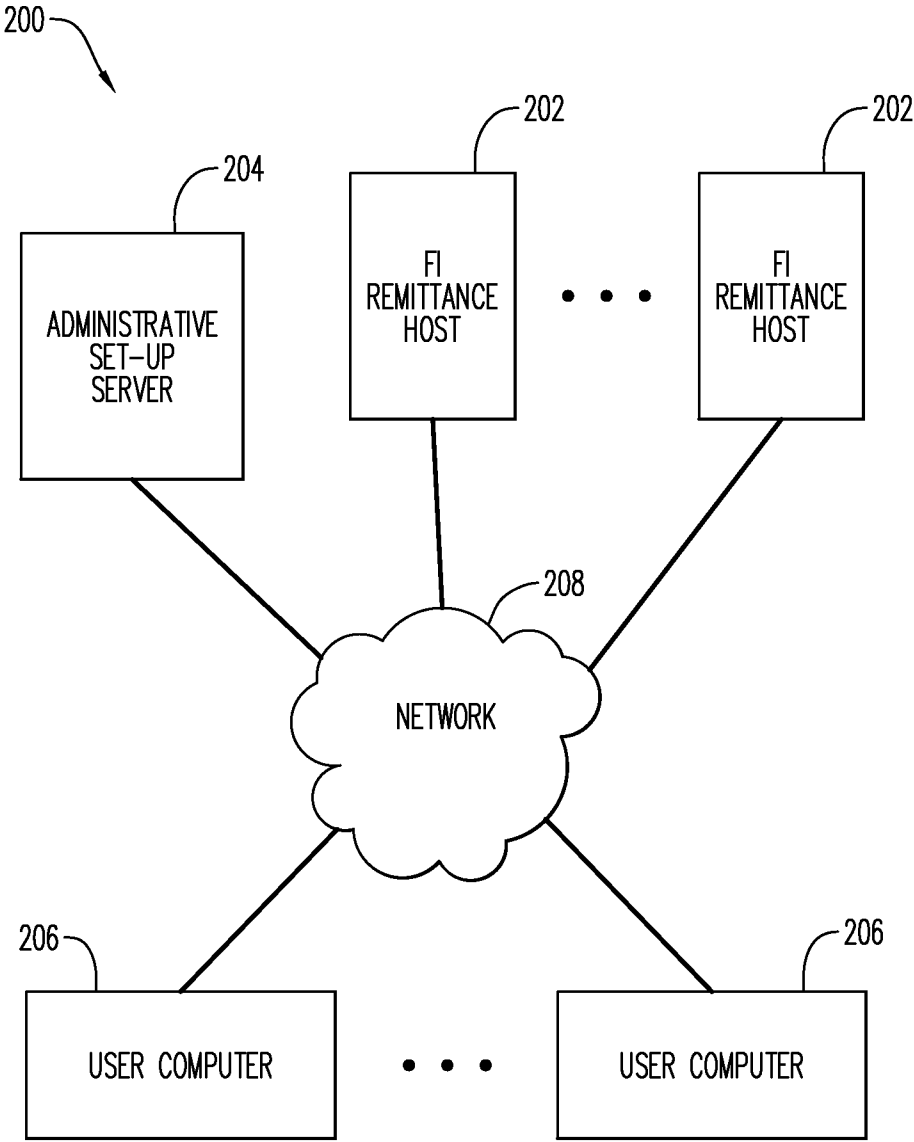

FIG. 2

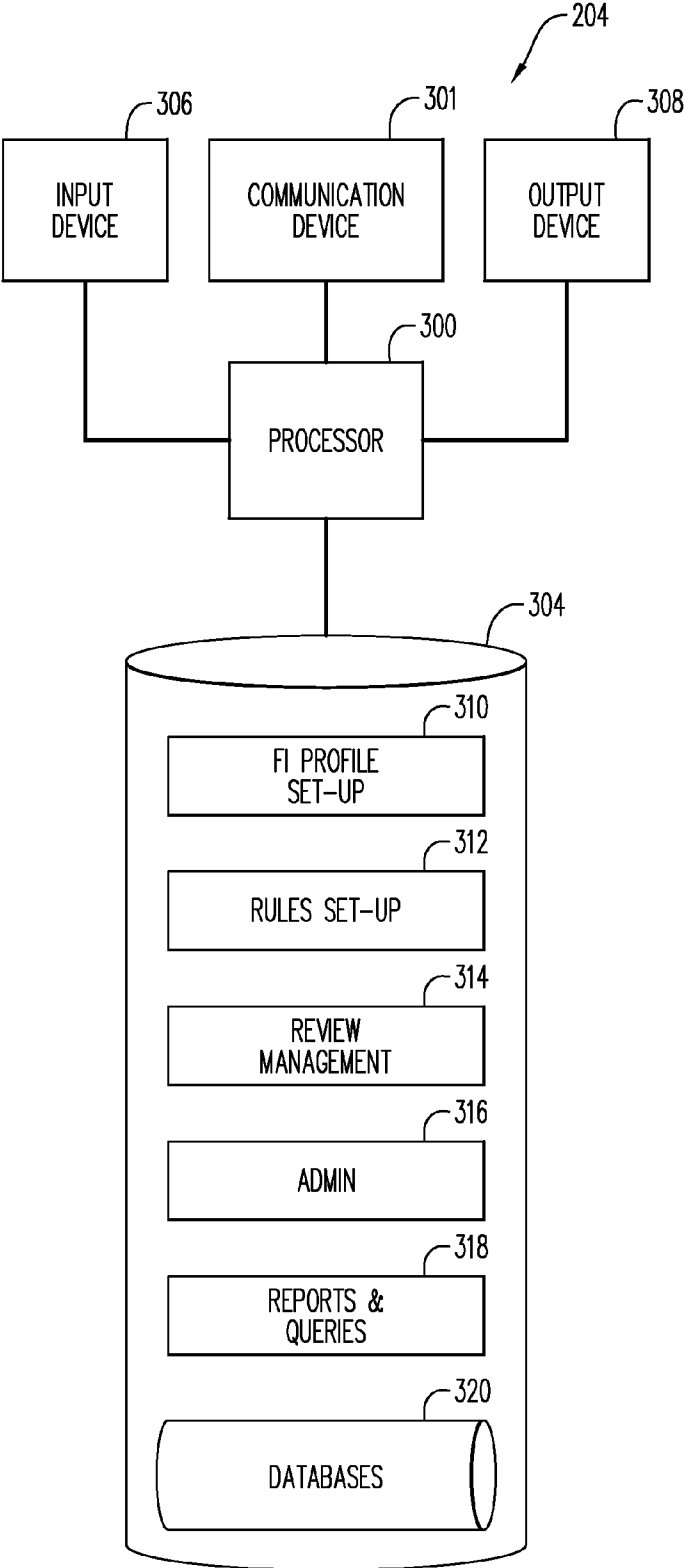

FIG. 3

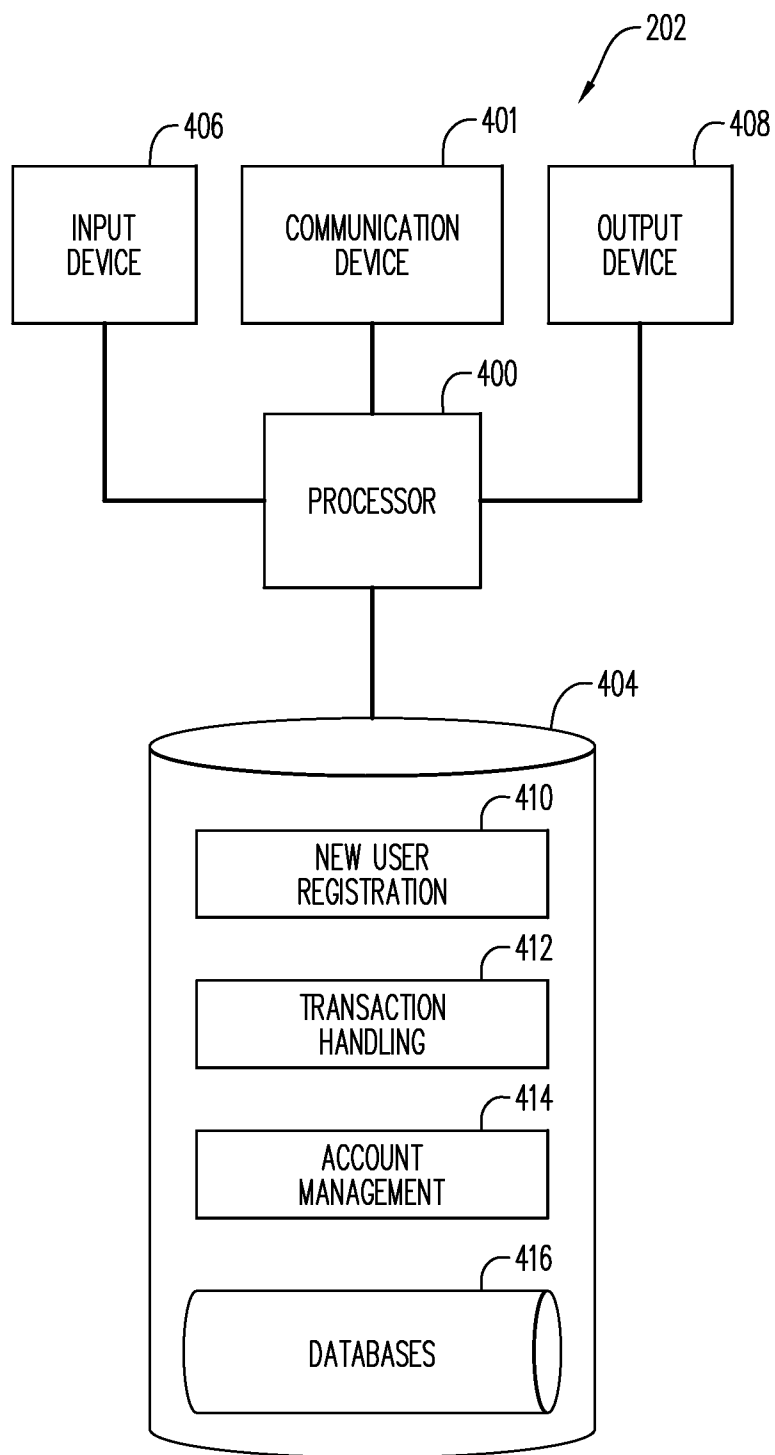

FIG. 4

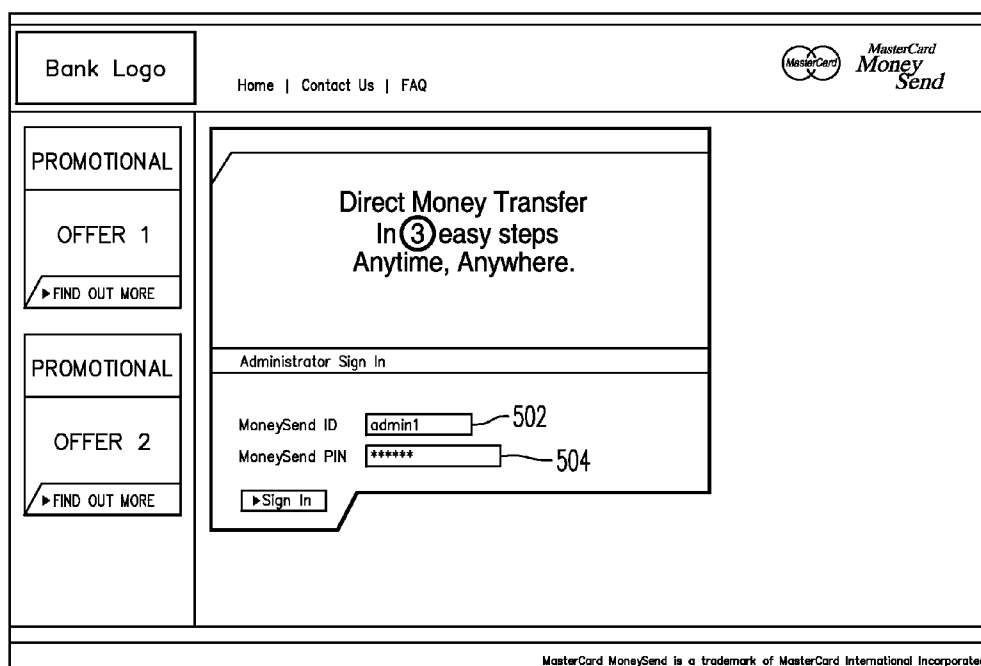

FIG. 5

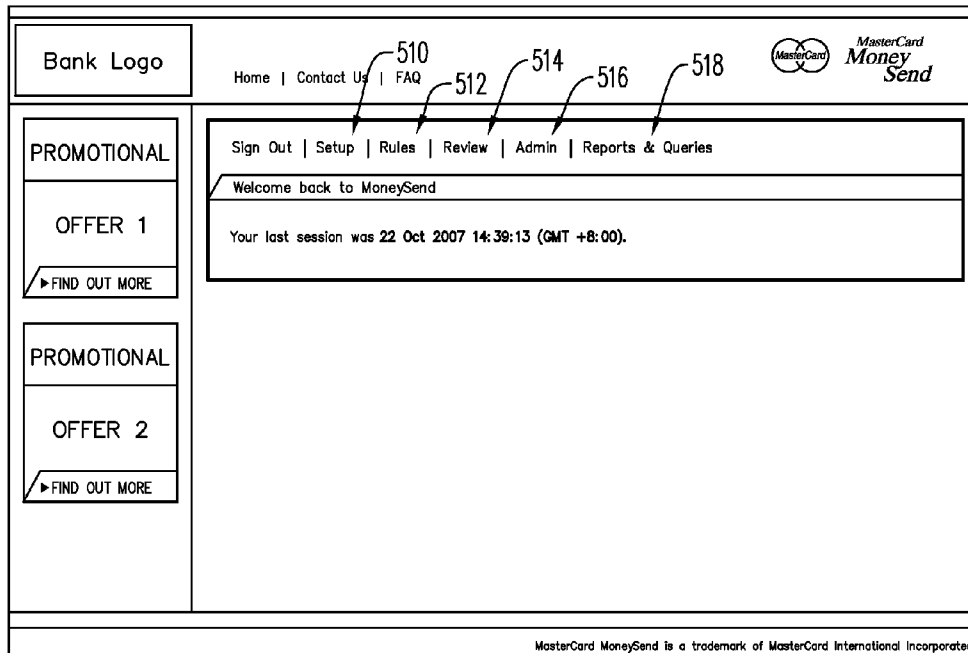

FIG. 5A

Bank Logo MasterCard MoneySend

Home | Contact Us | FAQ

Sign Out | Setup | Rules | Review | Admin | Reports & Queries 602

Acquirer Profile

*Mandatory Input.

Bank Name* ICA*

Country of Registration* Registered Address*

Contact*

Primary Phone No. Email*

Secondary Phone No. Email*

Business Hours* hrs hrs General Email*

Acquirer BIN Details

*Mandatory Input.

BIN(s)* 1. 2. 3.

< Prev 1 2 3 Next >

Global Transaction Limit Rules

*Mandatory Input.

Global Transaction Limit* Per Transaction Daily Monthly

Enable Transactions Disable Transactions

MasterCard MoneySend is a trademark of MasterCard International Incorporated

FIG. 6

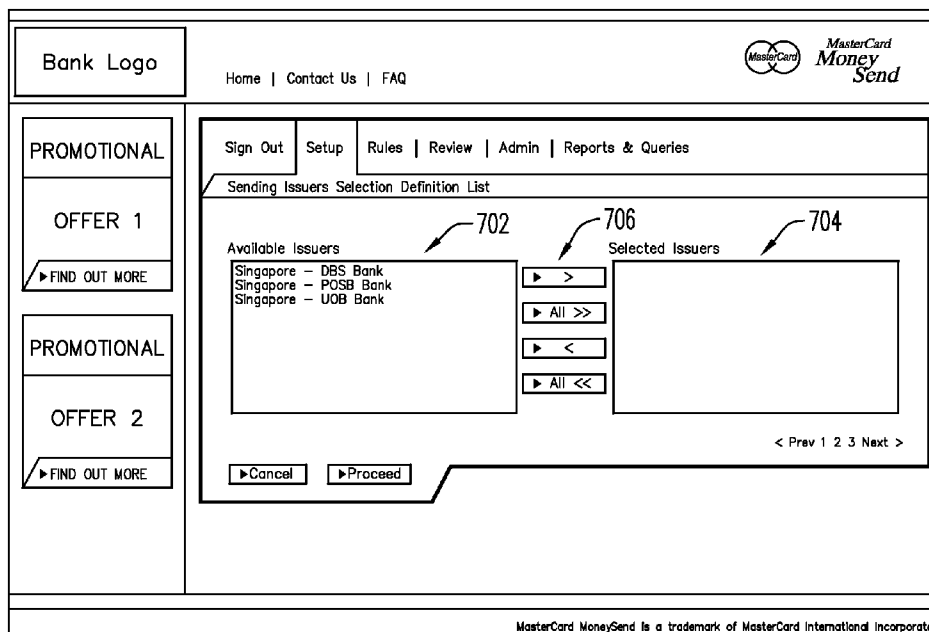

FIG. 7

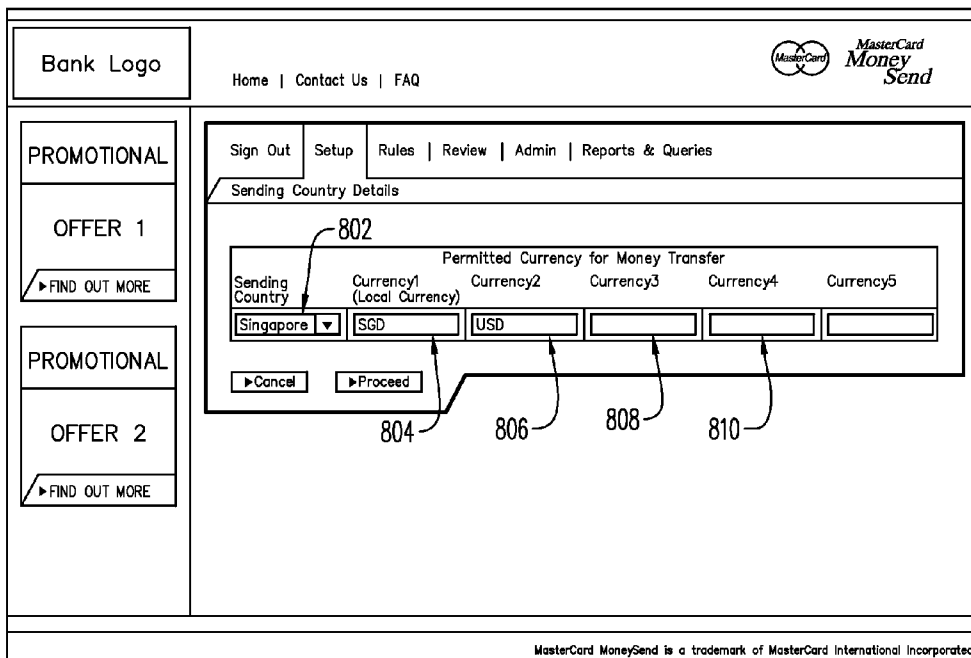

FIG. 8

Bank Logo

[Home](#) | [Contact Us](#) | [FAQ](#)

PROMOTIONAL

OFFER 1

▶ FIND OUT MORE

PROMOTIONAL

OFFER 2

▶ FIND OUT MORE

Sign Out
Setup
Rules
Review
Admin
Reports & Queries

Receiving Country Details

902

Permitted Currency to Receive Money Transfer

Receiving Country	Currency1 (Local Currency)	Currency2	Currency3	Currency4	Currency5
Singapore ▼	SGD	USD	EUR		
Malaysia ▼	MYR	USD			
Indonesia ▼	IDR	USD			
Thailand ▼	THB	USD			
Philippines ▼	PHP	USD	EUR		
India ▼	INR	USD			
Vietnam ▼	VND				
Cambodia ▼	KHR				
Laos ▼	LAK				
Brunei ▼	BND	USD	EUR		

▶ Cancel
▶ Proceed

MasterCard MoneySend is a trademark of MasterCard International Incorporated

FIG. 9

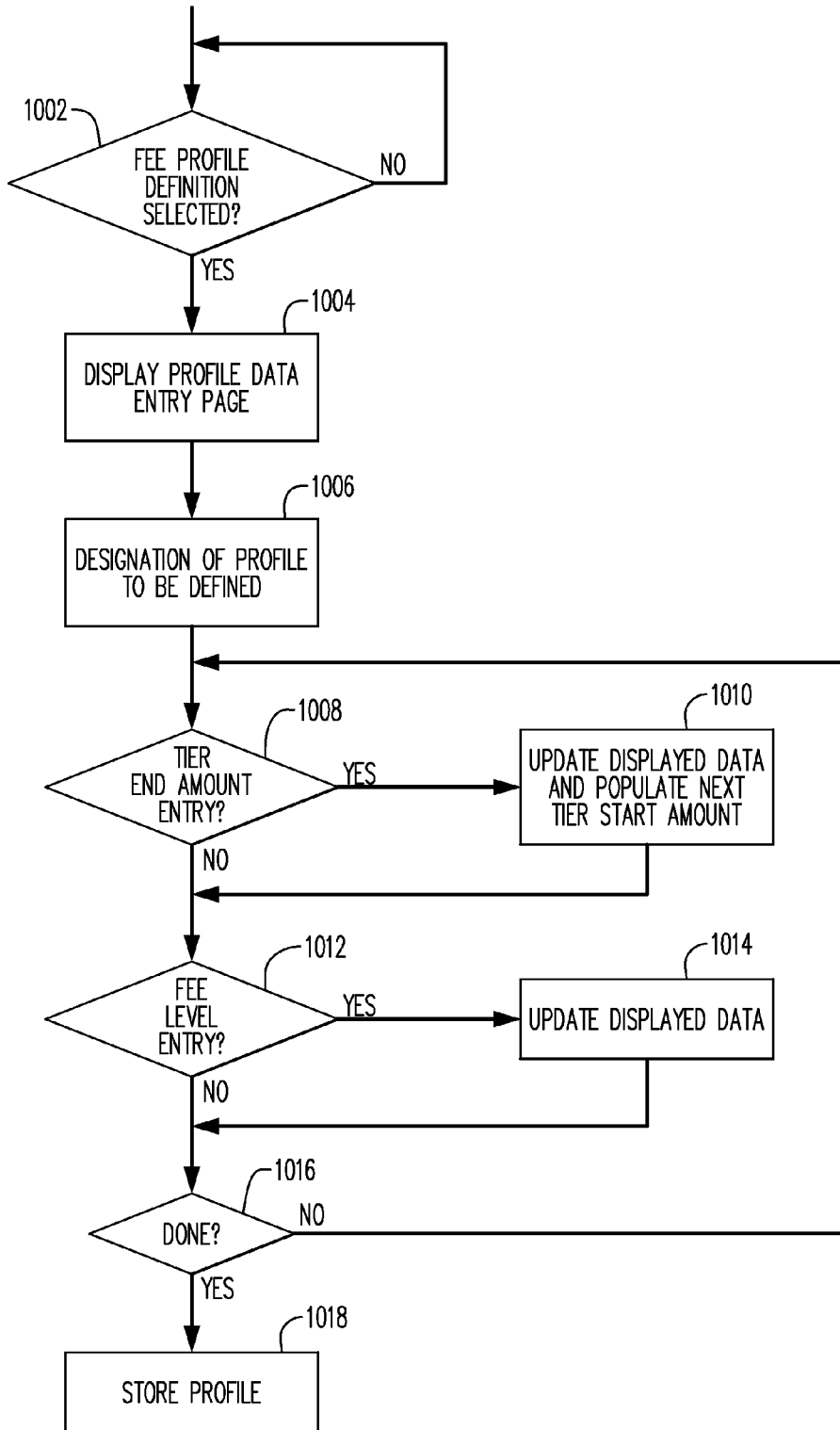



FIG. 10

Bank Logo

[Home](#) | [Contact Us](#) | [FAQ](#)



PROMOTIONAL

OFFER 1

▶ FIND OUT MORE

PROMOTIONAL

OFFER 2

▶ FIND OUT MORE

Sign Out | Setup
Rules
Review | Admin | Reports & Queries
1102

Service Fee Profile Details

No.	Available Profile
<input checked="" type="radio"/>	1. Default Profile
<input type="radio"/>	2. Profile 1
<input type="radio"/>	2. Profile 1

< Prev 1 2 3 Next >

▶ Add New
▶ Edit

Name of Profile

Service Fee defined in Currency

Tier	Tier Start Value	Tier End Value	Service Fee Flat Amount	Service Fee Variable Percentage of Transfer Amount
1	<input type="text" value="0"/>	<input type="text" value="100"/>	<input type="text" value="8"/>	<input type="text" value="0"/>
2	<input type="text" value=">100"/>	<input type="text" value="300"/>	<input type="text" value="8"/>	<input type="text" value="0"/>
3	<input type="text" value=">300"/>	<input type="text" value="500"/>	<input type="text" value="2"/>	<input type="text" value="0.75"/>
4	<input type="text" value=">500"/>	<input type="text" value="1000"/>	<input type="text" value="0"/>	<input type="text" value="0.50"/>
5	<input type="text" value=">1000"/>	<input type="text" value="9999"/>	<input type="text" value="0"/>	<input type="text" value="0.25"/>

▶ Cancel
▶ Proceed

MasterCard MoneySend is a trademark of MasterCard International Incorporated

FIG. 11

Bank Logo

[Home](#) | [Contact Us](#) | [FAQ](#)

PROMOTIONAL

OFFER 1

▶ FIND OUT MORE

PROMOTIONAL

OFFER 2

▶ FIND OUT MORE

Sign Out | Setup
Rules
Review | Admin | Reports & Queries

Service Fee Profile Details

No.	Available Profile
<input checked="" type="radio"/>	1. Default Profile
<input type="radio"/>	2. Profile 1
<input type="radio"/>	2. Profile 2

< Prev 1 2 3 Next >

▶ Add New
▶ Edit

Name of Profile Service Fee defined in Currency

Tier	Tier Start Value	Tier End Value	Service Fee Flat Amount	Service Fee Variable Percentage of Transfer Amount
1	<input type="text" value="0"/>	<input type="text" value="250"/>	<input type="text" value="8"/>	<input type="text" value="0"/>
2	<input type="text" value=">250"/>	<input type="text" value="300"/>	<input type="text" value="8"/>	<input type="text" value="0"/>
3	<input type="text" value=">300"/>	<input type="text" value="500"/>	<input type="text" value="2"/>	<input type="text" value="0.75"/>
4	<input type="text" value=">500"/>	<input type="text" value="1000"/>	<input type="text" value="0"/>	<input type="text" value="0.50"/>
5	<input type="text" value=">1000"/>	<input type="text" value="9999"/>	<input type="text" value="0"/>	<input type="text" value="0.25"/>

▶ Cancel
▶ Proceed

MasterCard MoneySend is a trademark of MasterCard International Incorporated

FIG. 12

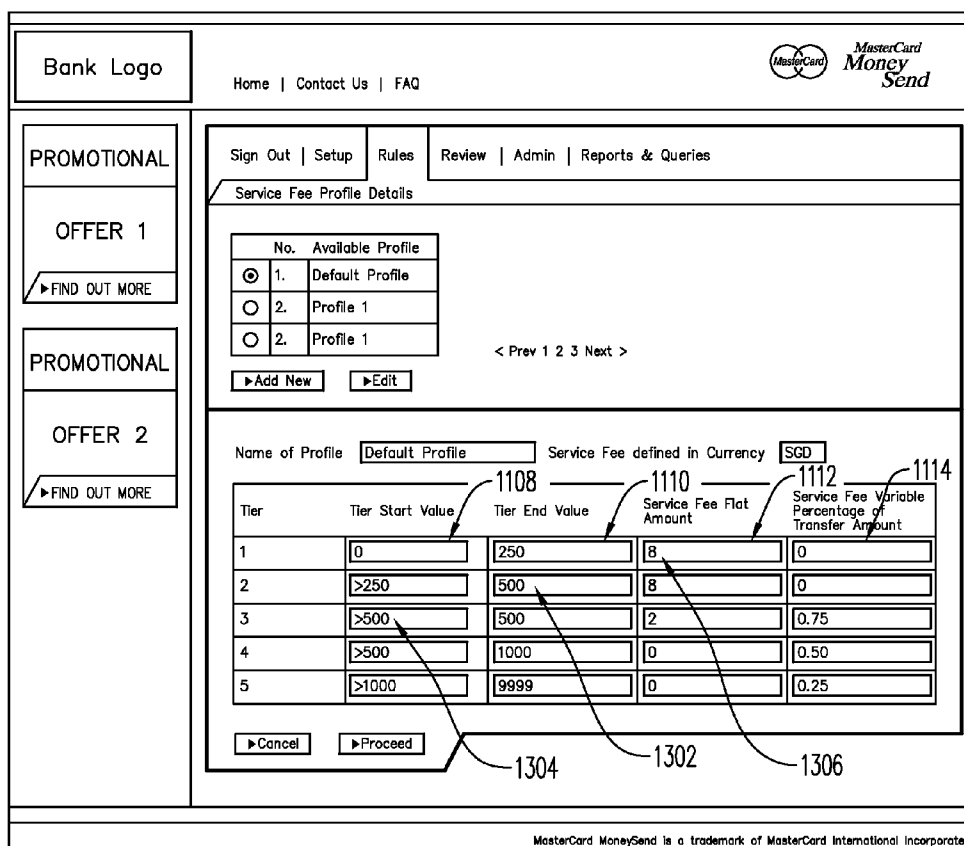

FIG. 13

Bank Logo

Home | Contact Us | FAQ

Sign Out | SetupRulesReview | Admin | Reports & Queries

Service Fee Profile Details

No.	Available Profile
<input checked="" type="radio"/> 1.	Default Profile
<input type="radio"/> 2.	Profile 1
<input type="radio"/> 2.	Profile 1

< Prev 1 2 3 Next >

▶Add New▶Edit

Name of Profile Service Fee defined in Currency

Tier	Tier Start Value	Tier End Value	Service Fee Flat Amount	Service Fee Variable Percentage of Transfer Amount
1	<input type="text" value="0"/>	<input type="text" value="250"/>	<input type="text" value="6"/>	<input type="text" value="0"/>
2	<input type="text" value=">250"/>	<input type="text" value="500"/>	<input type="text" value="8"/>	<input type="text" value="0"/>
3	<input type="text" value=">500"/>	<input type="text" value="750"/>	<input type="text" value="2"/>	<input type="text" value="0.75"/>
4	<input type="text" value=">750"/>	<input type="text" value="1000"/>	<input type="text" value="0"/>	<input type="text" value="0.50"/>
5	<input type="text" value=">1000"/>	<input type="text" value="9999"/>	<input type="text" value="0"/>	<input type="text" value="0.25"/>

▶Cancel▶Proceed

MasterCard MoneySend is a trademark of MasterCard International Incorporated

1408

▶Cancel

▶Proceed

1404

1402

1306

1406

FIG. 14

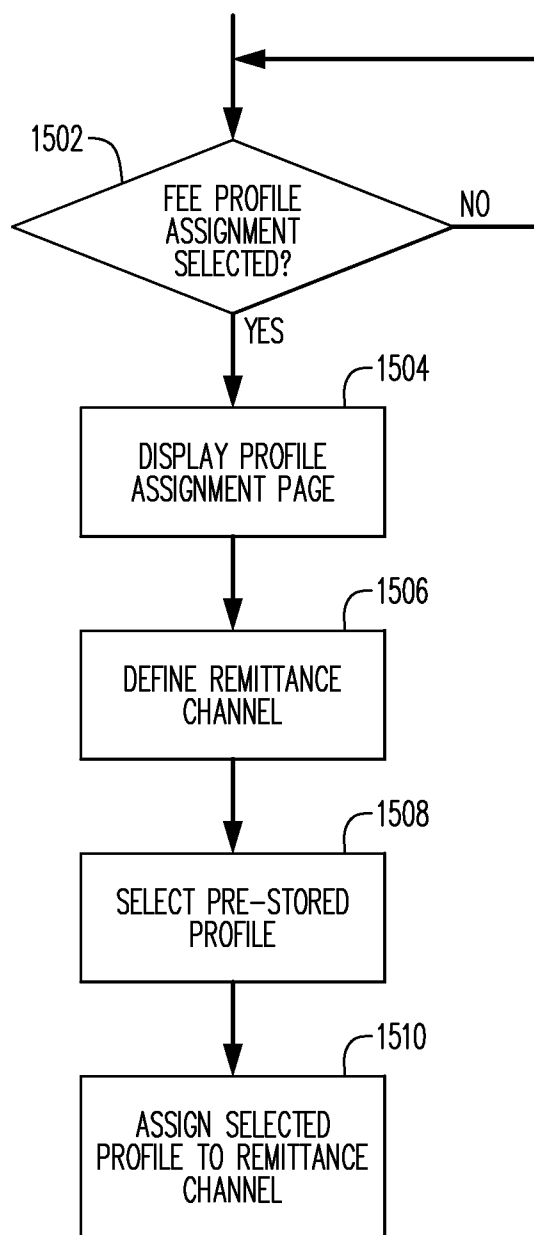



FIG. 15

Bank Logo

[Home](#) | [Contact Us](#) | [FAQ](#)



PROMOTIONAL

OFFER 1

▶ FIND OUT MORE

PROMOTIONAL

OFFER 2

▶ FIND OUT MORE

Sign Out | Setup
Rules
Review | Admin | Reports & Queries
1602

Service Fee Profile Assignment

No.	Send From Country	Send From Currency	Send To Country	Send To Currency
1.	<input type="text" value="Singapore"/>	<input type="text" value="Please Select"/>	<input type="text" value="Please Select"/>	<input type="text" value="Please Select"/>

1606

Available Profile

1608

▶ Assign

1614

1610

1604

1612

Tier	Tier Start Value	Tier End Value	Service Fee Flat Amount	Service Fee Variable Percentage of Transfer Amount
1	<input type="text"/>	<input type="text"/>	<input type="text"/>	<input type="text"/>
2	<input type="text"/>	<input type="text"/>	<input type="text"/>	<input type="text"/>
3	<input type="text"/>	<input type="text"/>	<input type="text"/>	<input type="text"/>
4	<input type="text"/>	<input type="text"/>	<input type="text"/>	<input type="text"/>
5	<input type="text"/>	<input type="text"/>	<input type="text"/>	<input type="text"/>

▶ Cancel
▶ Proceed

MasterCard MoneySend is a trademark of MasterCard International Incorporated

FIG. 16

Bank Logo

Home | Contact Us | FAQ



PROMOTIONAL

[Sign Out](#) | [Setup](#) | [Rules](#) | [Review](#) | [Admin](#) | [Reports & Queries](#)

Service Fee Profile Assignment

No.	Send From Country	Send From Currency	Send To Country	Send To Currency
1.	Singapore	SGD	Indonesia	USD

Available Profile

Please Select

Tier	Tier Start Value	Tier End Value	Service Fee Flat Amount	Service Fee Variable Percentage of Transfer Amount
1	<input type="text"/>	<input type="text"/>	<input type="text"/>	<input type="text"/>
2	<input type="text"/>	<input type="text"/>	<input type="text"/>	<input type="text"/>
3	<input type="text"/>	<input type="text"/>	<input type="text"/>	<input type="text"/>
4	<input type="text"/>	<input type="text"/>	<input type="text"/>	<input type="text"/>
5	<input type="text"/>	<input type="text"/>	<input type="text"/>	<input type="text"/>

MasterCard MoneySend is a trademark of MasterCard International Incorporated

FIG. 17

Bank Logo

Home | Contact Us | FAQ

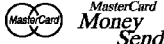

PROMOTIONAL

OFFER 1

▶ FIND OUT MORE

PROMOTIONAL

OFFER 2

▶ FIND OUT MORE

Sign Out | Setup
Rules
Review | Admin | Reports & Queries

Service Fee Profile Assignment

No.	Send From Country	Send From Currency	Send To Country	Send To Currency
1.	Singapore	SGD	Indonesia	USD

Available Profile Profile 1 ▶ Assign

Tier	Tier Start Value	Tier End Value	Service Fee Flat Amount	Service Fee Variable Percentage of Transfer Amount
1				
2				
3				
4				
5				

▶ Cancel
▶ Proceed

MasterCard MoneySend is a trademark of MasterCard International Incorporated

FIG. 18

Bank Logo

Home | Contact Us | FAQ



PROMOTIONAL

[Sign Out](#) | [Setup](#) | [Rules](#) | [Review](#) | [Admin](#) | [Reports & Queries](#)

Service Fee Profile Assignment

No.	Send From Country	Send From Currency	Send To Country	Send To Currency
1.	Singapore	SGD	Indonesia	USD

1604

Assigned Profile

Profile 1

Service Fee defined in Currency

SGD

[Change](#)

Tier	Tier Start Value	Tier End Value	Service Fee Flat Amount	Service Fee Variable Percentage of Transfer Amount
1	0	100	8	0
2	>100	300	8	0
3	>300	500	2	0.75
4	>500	1000	0	0.50
5	>1000	9999	0	0.25

[Cancel](#)

[Proceed](#)

1902

MasterCard MoneySend is a trademark of MasterCard International Incorporated

FIG. 19

Bank Logo



Home | Contact Us | FAQ

PROMOTIONAL

OFFER 1

▶ FIND OUT MORE

PROMOTIONAL

OFFER 2

▶ FIND OUT MORE

Sign Out | Setup
Rules
Review | Admin | Reports & Queries

Forex Markup Profile Details

No.	Available Profile
<input checked="" type="radio"/> 1.	Default Profile
<input type="radio"/> 2.	Profile 1
<input type="radio"/> 2.	Profile 2

< Prev 1 2 3 Next >

▶ Add New
▶ Edit

Tier	Tier Start Value	Tier End Value	Service Fee Flat Amount	Service Fee Variable Percentage of Transfer Amount
1	<input type="text" value="0"/>	<input type="text" value="100"/>	<input type="text" value="8"/>	<input type="text" value="0"/>
2	<input type="text" value=">100"/>	<input type="text" value="300"/>	<input type="text" value="8"/>	<input type="text" value="0"/>
3	<input type="text" value=">300"/>	<input type="text" value="500"/>	<input type="text" value="8"/>	<input type="text" value="0.75"/>
4	<input type="text" value=">500"/>	<input type="text" value="1000"/>	<input type="text" value="0"/>	<input type="text" value="0.50"/>
5	<input type="text" value=">1000"/>	<input type="text" value="9999"/>	<input type="text" value="0"/>	<input type="text" value="0.25"/>

▶ Cancel
▶ Proceed

MasterCard MoneySend is a trademark of MasterCard International Incorporated

FIG. 20

Bank Logo

[Home](#) | [Contact Us](#) | [FAQ](#)

PROMOTIONAL

OFFER 1

▶ FIND OUT MORE

PROMOTIONAL

OFFER 2

▶ FIND OUT MORE

Sign Out | Setup
Rules
Review | Admin | Reports & Queries

Forex Markup Profile Assignment

No.	Send Currency Code	Send Currency	Receive Country Code	Receive Currency
1.	<input type="text" value="Please Select"/>	<input type="text"/>	<input type="text" value="Please Select"/>	<input type="text"/>

Available Profile ▶ Assign

Tier	Tier Start Value	Tier End Value	Forex Mark-up
1	<input type="text"/>	<input type="text"/>	<input type="text"/>
2	<input type="text"/>	<input type="text"/>	<input type="text"/>
3	<input type="text"/>	<input type="text"/>	<input type="text"/>
4	<input type="text"/>	<input type="text"/>	<input type="text"/>
5	<input type="text"/>	<input type="text"/>	<input type="text"/>

▶ Cancel
▶ Proceed

MasterCard MoneySend is a trademark of MasterCard International Incorporated

FIG. 21

Bank Logo

[Home](#) | [Contact Us](#) | [FAQ](#)

PROMOTIONAL

OFFER 1

▶ FIND OUT MORE

PROMOTIONAL

OFFER 2

▶ FIND OUT MORE

Sign Out | Setup
Rules
Review | Admin | Reports & Queries

Transaction Limits Profile Details

No.	Available Profile
<input checked="" type="radio"/> 1.	Default Profile
<input type="radio"/> 2.	Profile 1
<input type="radio"/> 2.	Profile 2

2202

< Prev 1 2 3 Next >

▶Add New
▶Edit

Sending Country

Singapore ▼

	Max. Number of Transactions per Day	Max. Amount per Transaction	Cumulative Monthly Limit	Cumulative Annual Limit
Currency 1 (SGD)	0	500	5000	25000
Currency 2 (USD)	2	4000	8000	40000
Currency 3	0	0	0	0
Currency 4	0	0	0	0
Currency 5	0	0	0	0

2204

▶Cancel
▶Proceed

MasterCard MoneySend is a trademark of MasterCard International Incorporated

FIG. 22

Bank Logo

[Home](#) | [Contact Us](#) | [FAQ](#)

PROMOTIONAL

OFFER 1

▶ FIND OUT MORE

PROMOTIONAL

OFFER 2

▶ FIND OUT MORE

Sign Out | Setup
Rules
Review | Admin | Reports & Queries

Transaction Limits Profile Assignment

Selection Criteria 2302

First Name Last Name

Mobile Number

Transaction Limits Available Profile 2304

Please Select

Sending Country	Max. Number of Transactions per Day	Max. Amount per Transaction	Cumulative Monthly Limit	Cumulative Annual Limit
Singapore <input style="width: 20px;" type="text"/>	<input style="width: 40px;" type="text"/>	<input style="width: 40px;" type="text"/>	<input style="width: 40px;" type="text"/>	<input style="width: 40px;" type="text"/>
Currency 1 (SGD)	<input style="width: 40px;" type="text"/>	<input style="width: 40px;" type="text"/>	<input style="width: 40px;" type="text"/>	<input style="width: 40px;" type="text"/>
Currency 2 (USD)	<input style="width: 40px;" type="text"/>	<input style="width: 40px;" type="text"/>	<input style="width: 40px;" type="text"/>	<input style="width: 40px;" type="text"/>
Currency 3	<input style="width: 40px;" type="text"/>	<input style="width: 40px;" type="text"/>	<input style="width: 40px;" type="text"/>	<input style="width: 40px;" type="text"/>
Currency 4	<input style="width: 40px;" type="text"/>	<input style="width: 40px;" type="text"/>	<input style="width: 40px;" type="text"/>	<input style="width: 40px;" type="text"/>
Currency 5	<input style="width: 40px;" type="text"/>	<input style="width: 40px;" type="text"/>	<input style="width: 40px;" type="text"/>	<input style="width: 40px;" type="text"/>

MasterCard MoneySend is a trademark of MasterCard International Incorporated

FIG. 23

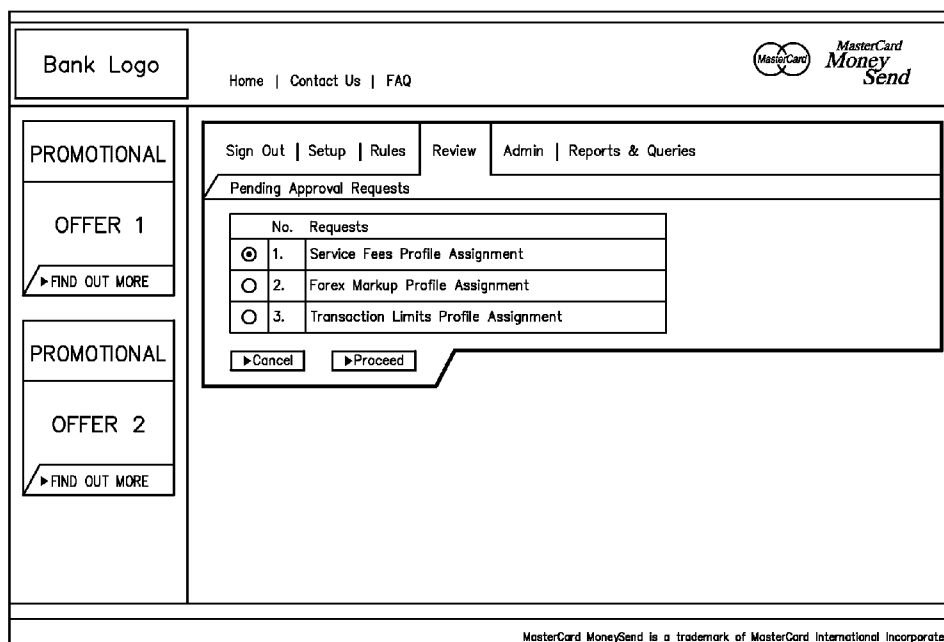



FIG. 24

Bank Logo

[Home](#) | [Contact Us](#) | [FAQ](#)



PROMOTIONAL

OFFER 1

▶ FIND OUT MORE

PROMOTIONAL

OFFER 2

▶ FIND OUT MORE

Sign Out | Setup | Rules
Review
Admin | Reports & Queries

Suspect Customers

No.	Account Name	Mobile Number	Blocked By	Date	
1.	Samuel Lim	65-Singapore 87251687	OFAC SDN List	19 Oct 2007 13: 26: 44 (GMT +08:00)	Blocked ▼
2.	John Smith	65-Singapore 65628687	Central Bank List	19 Oct 2007 13: 26: 44 (GMT +08:00)	Blocked ▼
3.	Sara Mariah	65-Singapore 91825687	Acquirer Bank List	19 Oct 2007 13: 26: 44 (GMT +08:00)	Blocked ▼
4.	Peter Jakson	65-Singapore 90125687	Manual Entry	19 Oct 2007 13: 26: 44 (GMT +08:00)	Blocked ▼
5.	James Jakson	65-Singapore 67195687	Manual Entry	19 Oct 2007 13: 26: 44 (GMT +08:00)	Blocked ▼

< Prev 1 2 3 Next >

▶ Cancel
▶ Proceed

MasterCard MoneySend is a trademark of MasterCard International Incorporated

FIG. 25

Bank Logo

[Home](#) | [Contact Us](#) | [FAQ](#)



PROMOTIONAL

OFFER 1

▶ FIND OUT MORE

PROMOTIONAL

OFFER 2

▶ FIND OUT MORE

Sign Out | Setup | Rules | Review
Admin
Reports & Queries

User Rights

No.	User Name	User ID	Email	Email	Access Rights	Status	
<input checked="" type="radio"/>	1.	Tom	Tom	tom@abcbank.com	Level A (Admin)	All	Active
<input type="radio"/>	2.	John	John	john@abcbank.com	Level M (Maker)	Reports, Uploads, Downloads, Trans, Limits, Serv. Fees, Forex	Active
<input type="radio"/>	3.	Sara	Sara	sara@abcbank.com	Level M (Maker)	Reports, Uploads, Downloads, Trans, Limits, Serv. Fees, Forex	<input type="text" value="Please Select"/>
<input type="radio"/>	4.	Peter	Peter	peter@abcbank.com	Level C (Checker)	Profiles, Rules, Exception	<input type="text" value="Please Select"/>
<input type="radio"/>	5.	Samuel	Samuel	samuel@abcbank.com	Level C (Checker)	Profiles, Rules, Exception	<input type="text" value="Please Select"/>

< Prev 1 2 3 Next >

▶ Add New
▶ Delete

▶ Cancel
▶ Proceed

MasterCard MoneySend is a trademark of MasterCard International Incorporated

FIG. 26

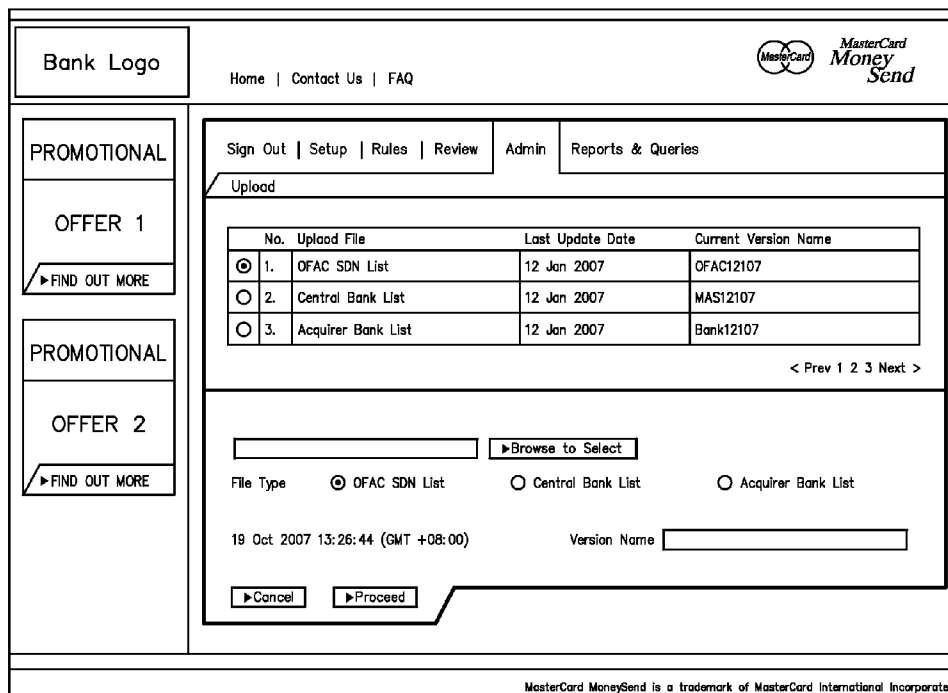

FIG. 27

Bank Logo	Home Contact Us FAQ 
PROMOTIONAL	Sign Out Setup Rules Review Admin Reports & Queries
OFFER 1 ▶ FIND OUT MORE	Suspect Customers Query by Name First Name Last Name <input type="text"/> <input type="text" value="Tom"/>
PROMOTIONAL	Query by Mobile Number Mobile Number <input type="text" value="65-Singapore"/> <input type="text"/>
OFFER 2 ▶ FIND OUT MORE	Query by Address Address City State Country Postal Code <input type="text"/> <input type="text"/> <input type="text"/> <input type="text" value="Select Country"/> <input type="text"/> ▶ Search
MasterCard MoneySend is a trademark of MasterCard International Incorporated	

FIG. 28



Bank Logo																																	
	Home Contact Us FAQ																																
PROMOTIONAL OFFER 1 <input type="button" value="▶ FIND OUT MORE"/>	Sign Out Setup Rules Review Admin Reports & Queries																																
PROMOTIONAL OFFER 2 <input type="button" value="▶ FIND OUT MORE"/>	Selection Criteria Query by Sender <table border="1" style="width: 100%; border-collapse: collapse;"> <thead> <tr> <th style="width: 25%;">Last Name</th> <th style="width: 25%;">Funding Country</th> <th style="width: 10%;">Funding Currency</th> <th style="width: 40%;">Mobile Number</th> </tr> </thead> <tbody> <tr> <td><input type="text" value="Smith"/></td> <td><input type="text" value="Singapore"/></td> <td><input type="text" value="SGD"/></td> <td><input type="text" value="65-Singapore 6591654667"/></td> </tr> </tbody> </table> Query by Receiver <table border="1" style="width: 100%; border-collapse: collapse;"> <thead> <tr> <th style="width: 25%;">Last Name</th> <th style="width: 15%;">Receiving City</th> <th style="width: 15%;">Receiving Country</th> <th style="width: 10%;">Funding Currency</th> <th style="width: 35%;">Receiver Account</th> </tr> </thead> <tbody> <tr> <td><input type="text" value="Smith"/></td> <td><input type="text" value="Jakarta"/></td> <td><input type="text" value="Indonesia"/></td> <td><input type="text" value="IDR"/></td> <td><input type="text" value="MasterCard"/></td> </tr> </tbody> </table> Query by Transaction <table border="1" style="width: 100%; border-collapse: collapse;"> <thead> <tr> <th style="width: 30%;">Transaction Ref.</th> <th style="width: 30%;">Transaction Date</th> <th style="width: 40%;">Transfer Amount</th> </tr> </thead> <tbody> <tr> <td><input type="text" value="123456"/></td> <td><input type="text" value="01/01/07"/> To <input type="text" value="01/03/07"/></td> <td><input type="text" value="5000"/></td> </tr> </tbody> </table> <table border="1" style="width: 100%; border-collapse: collapse;"> <thead> <tr> <th style="width: 25%;">Cumulative Monthly Amount</th> <th style="width: 25%;">Cumulative Annual Amount</th> <th style="width: 25%;">Transaction by Account</th> <th style="width: 25%;">Transactions Status</th> </tr> </thead> <tbody> <tr> <td><input type="text" value="20000"/></td> <td><input type="text" value="50000"/></td> <td><input type="text" value="Bank"/></td> <td><input type="text" value="Success"/></td> </tr> </tbody> </table> <input type="button" value="▶ Search"/>	Last Name	Funding Country	Funding Currency	Mobile Number	<input type="text" value="Smith"/>	<input type="text" value="Singapore"/>	<input type="text" value="SGD"/>	<input type="text" value="65-Singapore 6591654667"/>	Last Name	Receiving City	Receiving Country	Funding Currency	Receiver Account	<input type="text" value="Smith"/>	<input type="text" value="Jakarta"/>	<input type="text" value="Indonesia"/>	<input type="text" value="IDR"/>	<input type="text" value="MasterCard"/>	Transaction Ref.	Transaction Date	Transfer Amount	<input type="text" value="123456"/>	<input type="text" value="01/01/07"/> To <input type="text" value="01/03/07"/>	<input type="text" value="5000"/>	Cumulative Monthly Amount	Cumulative Annual Amount	Transaction by Account	Transactions Status	<input type="text" value="20000"/>	<input type="text" value="50000"/>	<input type="text" value="Bank"/>	<input type="text" value="Success"/>
Last Name	Funding Country	Funding Currency	Mobile Number																														
<input type="text" value="Smith"/>	<input type="text" value="Singapore"/>	<input type="text" value="SGD"/>	<input type="text" value="65-Singapore 6591654667"/>																														
Last Name	Receiving City	Receiving Country	Funding Currency	Receiver Account																													
<input type="text" value="Smith"/>	<input type="text" value="Jakarta"/>	<input type="text" value="Indonesia"/>	<input type="text" value="IDR"/>	<input type="text" value="MasterCard"/>																													
Transaction Ref.	Transaction Date	Transfer Amount																															
<input type="text" value="123456"/>	<input type="text" value="01/01/07"/> To <input type="text" value="01/03/07"/>	<input type="text" value="5000"/>																															
Cumulative Monthly Amount	Cumulative Annual Amount	Transaction by Account	Transactions Status																														
<input type="text" value="20000"/>	<input type="text" value="50000"/>	<input type="text" value="Bank"/>	<input type="text" value="Success"/>																														
<small>MasterCard MoneySend is a trademark of MasterCard International Incorporated</small>																																	

FIG. 29

Bank Logo

[Home](#) | [Contact Us](#) | [FAQ](#)



PROMOTIONAL

OFFER 1

▶ FIND OUT MORE

Sign Out | Setup | Rules | Review | Admin
Reports & Queries

Report

No.	Report No.	Report	Frequency	Last Download Date	Current Version Name	User Access ID
<input checked="" type="radio"/>	1. IP72010-AA	Clearing Cycle Acknowledgement Report	Daily	01 Jan 2007	05 Jan 2007	aaaaa
<input type="radio"/>	2. IP727020-AA	Clearing Cycle Notification Report	Daily	01 Jan 2007	15 Dec 2006	aaaaa
<input type="radio"/>	3. IP728010-AA	Clearing Cycle Summary Report	Daily	01 Jan 2007	10 Dec 2006	aaaaa
<input type="radio"/>	4. SWCHD363	Daily Control Report	Daily	01 Jan 2007	13 Jan 2007	aaaaa
<input type="radio"/>	5. ABCD-4534	Service Fee Profile Report	Daily	01 Jan 2007	02 Jan 2007	aaaaa
<input type="radio"/>	6. ABCD-1234	Service Fee Profile Assignment Report	Daily	01 Jan 2007	17 Jan 2007	bbbbbb
<input type="radio"/>	7. ABCD-7753	Forex Markup Profile Report	Daily	01 Jan 2007	18 Jan 2007	aaaaa
<input type="radio"/>	8. ABCD-3423	Forex Markup Profile Assignment Report	Daily	01 Jan 2007	11 Jan 2007	bbbbbb
<input type="radio"/>	9. SWCHM363	Monthly Control Report	Daily	01 Jan 2007	13 Jan 2007	bbbbbb

< Prev 1 2 3 Next >

▶ Print
▶ Export to Excel

MasterCard MoneySend is a trademark of MasterCard International Incorporated

FIG. 30

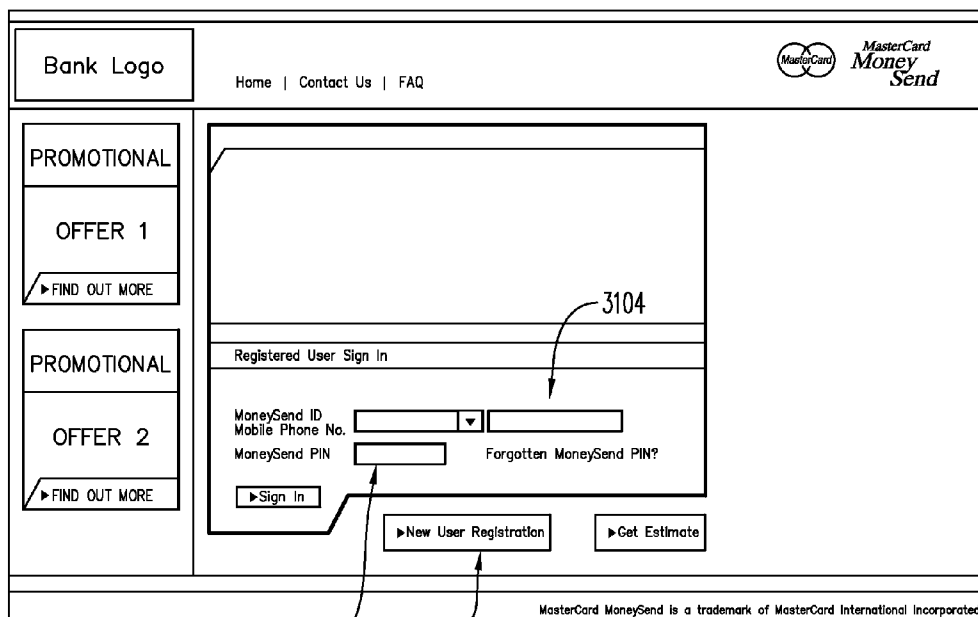

3106

3102

FIG. 31

<p>Bank Logo</p>	<p>Home Contact Us FAQ</p> 																																				
<p>PROMOTIONAL</p> <p>OFFER 1</p> <p>▶ FIND OUT MORE</p>	<div data-bbox="497 848 1268 869">Personal Details</div> <p>*Mandatory input</p> <table border="0"> <tr> <td>First Name*</td> <td><input type="text" value="John"/></td> <td>Address*</td> <td><input type="text" value="22-02, Draycott Dr."/> ▼</td> </tr> <tr> <td>Middle Initial</td> <td><input type="text" value="K"/></td> <td></td> <td><input type="text" value=""/> ▲</td> </tr> <tr> <td>Last Name*</td> <td><input type="text" value="Smith"/></td> <td>City*</td> <td><input type="text" value="Singapore"/></td> </tr> <tr> <td>Passport <input checked="" type="radio"/> IC <input type="radio"/> *</td> <td><input type="text" value="E4456767"/></td> <td>State*</td> <td><input type="text" value=""/></td> </tr> <tr> <td>Date of Birth*</td> <td><input type="text" value="23"/> dd <input type="text" value="03"/> mm <input type="text" value="1979"/> yyyy</td> <td>Country*</td> <td><input type="text" value="Singapore"/> ▼</td> </tr> <tr> <td>Email*</td> <td><input type="text" value="john.smith@yahoo.com"/></td> <td>Postal Code*</td> <td><input type="text" value="24811"/></td> </tr> </table> <div data-bbox="497 1108 1268 1129">Sign In and Security Information</div> <p>*Mandatory input</p> <table border="0"> <tr> <td>Mobile No.*</td> <td><input type="text" value="65-Singapore"/> ▼ <input type="text" value="Singapore"/></td> <td>Security Question*</td> <td><input type="text" value="Favorite Song"/> ▼</td> </tr> <tr> <td>PIN (6-8 digits)*</td> <td><input type="text" value="*****"/></td> <td>Security Answer*</td> <td><input type="text" value="Candle in the Wind"/></td> </tr> <tr> <td>Confirm PIN*</td> <td><input type="text" value="*****"/></td> <td></td> <td></td> </tr> </table> <p><input type="checkbox"/> I have read and I accept the Terms & Conditions.</p> <p><input type="button" value="▶Cancel"/> <input type="button" value="▶Proceed"/></p>	First Name*	<input type="text" value="John"/>	Address*	<input type="text" value="22-02, Draycott Dr."/> ▼	Middle Initial	<input type="text" value="K"/>		<input type="text" value=""/> ▲	Last Name*	<input type="text" value="Smith"/>	City*	<input type="text" value="Singapore"/>	Passport <input checked="" type="radio"/> IC <input type="radio"/> *	<input type="text" value="E4456767"/>	State*	<input type="text" value=""/>	Date of Birth*	<input type="text" value="23"/> dd <input type="text" value="03"/> mm <input type="text" value="1979"/> yyyy	Country*	<input type="text" value="Singapore"/> ▼	Email*	<input type="text" value="john.smith@yahoo.com"/>	Postal Code*	<input type="text" value="24811"/>	Mobile No.*	<input type="text" value="65-Singapore"/> ▼ <input type="text" value="Singapore"/>	Security Question*	<input type="text" value="Favorite Song"/> ▼	PIN (6-8 digits)*	<input type="text" value="*****"/>	Security Answer*	<input type="text" value="Candle in the Wind"/>	Confirm PIN*	<input type="text" value="*****"/>		
First Name*	<input type="text" value="John"/>	Address*	<input type="text" value="22-02, Draycott Dr."/> ▼																																		
Middle Initial	<input type="text" value="K"/>		<input type="text" value=""/> ▲																																		
Last Name*	<input type="text" value="Smith"/>	City*	<input type="text" value="Singapore"/>																																		
Passport <input checked="" type="radio"/> IC <input type="radio"/> *	<input type="text" value="E4456767"/>	State*	<input type="text" value=""/>																																		
Date of Birth*	<input type="text" value="23"/> dd <input type="text" value="03"/> mm <input type="text" value="1979"/> yyyy	Country*	<input type="text" value="Singapore"/> ▼																																		
Email*	<input type="text" value="john.smith@yahoo.com"/>	Postal Code*	<input type="text" value="24811"/>																																		
Mobile No.*	<input type="text" value="65-Singapore"/> ▼ <input type="text" value="Singapore"/>	Security Question*	<input type="text" value="Favorite Song"/> ▼																																		
PIN (6-8 digits)*	<input type="text" value="*****"/>	Security Answer*	<input type="text" value="Candle in the Wind"/>																																		
Confirm PIN*	<input type="text" value="*****"/>																																				
<p>MasterCard MoneySend is a trademark of MasterCard International Incorporated</p>																																					

FIG. 32



Bank Logo	Home Contact Us FAQ 
PROMOTIONAL OFFER 1 ▶ FIND OUT MORE	<p data-bbox="538 911 849 932">Sign Out Send Estimate My Account</p> <p data-bbox="538 949 660 970">Funding Account</p> <p data-bbox="538 987 660 1008">*Mandatory input</p> <p data-bbox="538 1033 707 1054"><input checked="" type="radio"/> MasterCard </p> <p data-bbox="898 1033 1020 1054"><input type="radio"/> Bank Account</p> <p data-bbox="538 1066 862 1087">Card No.* <input type="text" value="*****"/></p> <p data-bbox="898 1066 1215 1087">Bank <input type="text" value=""/></p> <p data-bbox="538 1092 783 1113">Expiry Date* <input type="text" value="Jan"/> <input type="text" value="2008"/></p> <p data-bbox="898 1092 1215 1113">Sort Code <input type="text" value="*****"/></p> <p data-bbox="538 1117 862 1138">CVC2* <input type="text" value="***"/></p> <p data-bbox="898 1117 1215 1138">Bank Account <input type="text" value="M949767567"/></p> <p data-bbox="538 1142 862 1163">(What is This?)</p> <p data-bbox="898 1142 1215 1163">Account at <input type="text" value=""/></p> <p data-bbox="548 1201 621 1222"><input type="button" value="▶Cancel"/></p> <p data-bbox="654 1201 726 1222"><input type="button" value="▶Proceed"/></p>
PROMOTIONAL OFFER 2 ▶ FIND OUT MORE	MasterCard MoneySend is a trademark of MasterCard International Incorporated

FIG. 33

<p>Bank Logo</p>	<p style="text-align: right;">  </p> <p>Home Contact Us FAQ</p>																																
<p>PROMOTIONAL</p> <p>OFFER 1</p> <p>▶ FIND OUT MORE</p>	<p>Sign Out Send Estimate My Account</p>																																
<p>PROMOTIONAL</p> <p>OFFER 2</p> <p>▶ FIND OUT MORE</p>	<p>Receiver Details</p> <p>*Mandatory input</p> <table border="0"> <tr> <td>First Name*</td> <td><input type="text" value="Maria"/></td> <td>City*</td> <td><input type="text" value="Jakarta"/></td> </tr> <tr> <td>Middle Initial</td> <td><input type="text" value="J"/></td> <td>State</td> <td><input type="text"/></td> </tr> <tr> <td>Last Name*</td> <td><input type="text" value="Smith"/></td> <td>Country*</td> <td><input type="text" value="Indonesia"/></td> </tr> <tr> <td>Receiver Description*</td> <td><input type="text" value="Mother"/></td> <td>Postal Code*</td> <td><input type="text" value="455533"/></td> </tr> <tr> <td>Address*</td> <td><input type="text" value="22-02, Draycott Dr."/> <input type="button" value="▲"/></td> <td>Email</td> <td><input type="text" value="maria.smith@hotmail.com"/></td> </tr> <tr> <td></td> <td></td> <td>Mobile No.</td> <td><input type="text" value="65-Singapore"/> <input type="text" value="93266266"/></td> </tr> </table> <p>Receiver Account Details</p> <p>*Mandatory input</p> <table border="0"> <tr> <td> <input checked="" type="radio"/> MasterCard / Maestro </td> <td> <input type="radio"/> Bank Account </td> </tr> <tr> <td> Issuer Bank* <input type="text" value="Select Bank"/> </td> <td> Bank <input type="text"/> </td> </tr> <tr> <td> Card No.* <input type="text" value="*****"/> </td> <td> Sort Code <input type="text" value="*****"/> </td> </tr> <tr> <td> Expiry Date* <input type="text" value="Jan"/> <input type="text" value="2008"/> </td> <td> Bank Account <input type="text" value="M949767567"/> </td> </tr> </table> <p> <input type="button" value="▶ Cancel"/> <input type="button" value="▶ Proceed"/> </p>	First Name*	<input type="text" value="Maria"/>	City*	<input type="text" value="Jakarta"/>	Middle Initial	<input type="text" value="J"/>	State	<input type="text"/>	Last Name*	<input type="text" value="Smith"/>	Country*	<input type="text" value="Indonesia"/>	Receiver Description*	<input type="text" value="Mother"/>	Postal Code*	<input type="text" value="455533"/>	Address*	<input type="text" value="22-02, Draycott Dr."/> <input type="button" value="▲"/>	Email	<input type="text" value="maria.smith@hotmail.com"/>			Mobile No.	<input type="text" value="65-Singapore"/> <input type="text" value="93266266"/>	<input checked="" type="radio"/> MasterCard / Maestro	<input type="radio"/> Bank Account	Issuer Bank* <input type="text" value="Select Bank"/>	Bank <input type="text"/>	Card No.* <input type="text" value="*****"/>	Sort Code <input type="text" value="*****"/>	Expiry Date* <input type="text" value="Jan"/> <input type="text" value="2008"/>	Bank Account <input type="text" value="M949767567"/>
First Name*	<input type="text" value="Maria"/>	City*	<input type="text" value="Jakarta"/>																														
Middle Initial	<input type="text" value="J"/>	State	<input type="text"/>																														
Last Name*	<input type="text" value="Smith"/>	Country*	<input type="text" value="Indonesia"/>																														
Receiver Description*	<input type="text" value="Mother"/>	Postal Code*	<input type="text" value="455533"/>																														
Address*	<input type="text" value="22-02, Draycott Dr."/> <input type="button" value="▲"/>	Email	<input type="text" value="maria.smith@hotmail.com"/>																														
		Mobile No.	<input type="text" value="65-Singapore"/> <input type="text" value="93266266"/>																														
<input checked="" type="radio"/> MasterCard / Maestro	<input type="radio"/> Bank Account																																
Issuer Bank* <input type="text" value="Select Bank"/>	Bank <input type="text"/>																																
Card No.* <input type="text" value="*****"/>	Sort Code <input type="text" value="*****"/>																																
Expiry Date* <input type="text" value="Jan"/> <input type="text" value="2008"/>	Bank Account <input type="text" value="M949767567"/>																																
<p style="text-align: center; font-size: small;">MasterCard MoneySend is a trademark of MasterCard International Incorporated</p>																																	

FIG. 34

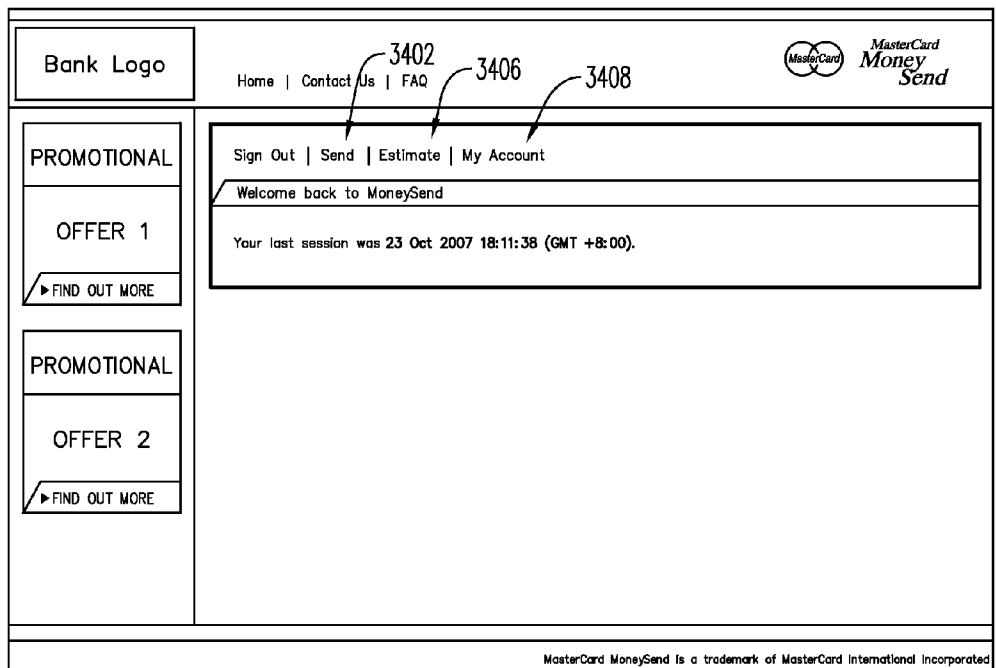



FIG. 34A

Bank Logo

[Home](#) | [Contact Us](#) | [FAQ](#)



PROMOTIONAL

OFFER 1

▶ FIND OUT MORE

PROMOTIONAL

OFFER 2

▶ FIND OUT MORE

Sign Out | Send | Estimate
My Account

Funding Account

Select Funding Account

No.	Account	Account Number
<input checked="" type="radio"/> 1.	MasterCard	XXXX XXXX XXXX 1234
<input type="radio"/> 2.	Maestro	XXXX XXXX XXXX 8888
<input type="radio"/> 3.	ABC Bank	Not Displayed

< Prev 1 2 3 Next >

▶ Add New ▶ Delete

*Mandatory input

MasterCard 
 Bank Account

Card No.*
Bank

Expiry Date*
Sort Code

CVC2* (What is This?)
Bank Account

Account at

▶ Cancel ▶ Proceed

MasterCard MoneySend is a trademark of MasterCard International Incorporated

FIG. 35

Bank Logo

[Home](#) | [Contact Us](#) | [FAQ](#)



PROMOTIONAL

OFFER 1

▶ FIND OUT MORE

PROMOTIONAL

OFFER 2

▶ FIND OUT MORE

Sign Out | Send | Estimate
My Account

Receiver Details

Select Receiver Account

No.	Account	Account Number
<input checked="" type="radio"/> 1.	MasterCard	XXXX XXXX XXXX 1234
<input type="radio"/> 2.	Maestro	XXXX XXXX XXXX 8888
<input type="radio"/> 3.	ABC Bank	Not Displayed

< Prev 1 2 3 Next >

▶ Add New
▶ Delete

***Mandatory input**

First Name*	<input type="text" value="Maria"/>	City*	<input type="text" value="Jakarta"/>
Middle Initial	<input type="text" value="J"/>	State	<input type="text"/>
Last Name*	<input type="text" value="Smith"/>	Country*	<input type="text" value="Indonesia"/>
Receiver Description*	<input type="text" value="Mother"/>	Postal Code*	<input type="text" value="455533"/>
Address*	<input type="text" value="23, Jln. Sudirman"/>	Email	<input type="text" value="maria.smith@hotmail.com"/>
		Mobile No.	<input type="text" value="65-Singapore"/> <input type="text" value="81678888s"/>

Receiver Account Details

***Mandatory input**

MasterCard / Maestro

Issuer Bank*

Card No.*

Expiry Date*

Bank Account

Bank

Sart Code

Bank Account

▶ Cancel
▶ Proceed

MasterCard MoneySend is a trademark of MasterCard International Incorporated

FIG. 36

Bank Logo

[Home](#) | [Contact Us](#) | [FAQ](#)



PROMOTIONAL

OFFER 1

▶ FIND OUT MORE

Sign Out | Send | Estimate
My Account

Transaction History

Enter Selection Criteria.

Date

From: Jan 2007

To: Jun 2007

Trans Reference:

Receiver:

PROMOTIONAL

OFFER 2

▶ FIND OUT MORE

#	Date	Time (GMT +08:00)	Reference	Status	Receiving Currency	Amount Transferred	Receiver Name	More Information
1.	05 Jan 2007	10:00:00	23651	Success	IDR	500,000	Maria K. Smith	<input type="button" value="Details"/>
1.	06 Jan 2007	10:00:00	23652	Success	IDR	500,000	Mother	<input type="button" value="Details"/>
1.	07 Jan 2007	10:00:00	23653	Success	IDR	500,000	Kid's School	<input type="button" value="Details"/>

< Prev 1 2 3 Next >

MasterCard MoneySend is a trademark of MasterCard International Incorporated

FIG. 37

Bank Logo

[Home](#) | [Contact Us](#) | [FAQ](#)



PROMOTIONAL

OFFER 1

▶ FIND OUT MORE

PROMOTIONAL

OFFER 2

▶ FIND OUT MORE

[Sign Out](#) | [Send](#) | [Estimate](#) | [My Account](#)

Funding and Receiver Accounts

Select Funding Account

No.	Account	Account Number
<input checked="" type="radio"/>	1. MasterCard	XXXX XXXX XXXX 1234
<input type="radio"/>	2. Maestro	XXXX XXXX XXXX 8888
<input type="radio"/>	3. ABC Bank	Not Displayed

< Prev 1 2 3 Next >

Select Receiver Account

No.	Account	Account Number
<input checked="" type="radio"/>	1. Mother	XXXX XXXX XXXX 567B
<input type="radio"/>	2. Elder Care	XXXX XXXX XXXX 3456
<input type="radio"/>	3. Kid's School	Bank Name

< Prev 1 2 3 Next >

MoneySend Transaction

*Mandatory Input.
Please enter the "Transfer Amount" you wish to send from your Singapore SGD Funding Account to your Indonesia IDR Receiver Account

Transfer Amount* SGD ▼ 101.62

[▶ Get Estimate](#)

MasterCard MoneySend is a trademark of MasterCard International Incorporated

FIG. 38

Bank Logo

[Home](#) | [Contact Us](#) | [FAQ](#)

Sign Out
Send
Estimate | My Account

Funding and Receiver Accounts

Select Funding Account

No.	Account	Account Number
<input checked="" type="radio"/> 1.	MasterCard	XXXX XXXX XXXX 1234
<input type="radio"/> 2.	Maestro	XXXX XXXX XXXX 8888
<input type="radio"/> 3.	ABC Bank	Not Displayed

< Prev 1 2 3 Next >

Select Receiver Account

No.	Account	Account Number
<input checked="" type="radio"/> 1.	Mother	XXXX XXXX XXXX 5678
<input type="radio"/> 2.	Elder Care	XXXX XXXX XXXX 3456
<input type="radio"/> 3.	Kid's School	Bank Name

< Prev 1 2 3 Next >

MoneySend Transaction

*Mandatory Input.

Please enter the "Transfer Amount" you wish to send from your Singapore SGD Funding Account to your Indonesia IDR Receiver Account

Transfer Amount* SGD ▼ 101.62

▶Get Estimate

Rates and Charges Estimate

Transfer Amount	101.62	SGD	
Service Charges	4.00	SGD	3902
Total Payable	105.62	SGD	
Receive Amount	100,000.00	IDR	

Exchange Rate: 1 Funding Currency = x Receiving Currency

I have read and I accept the Terms & Conditions.

3904

▶Cancel
▶Proceed

MasterCard MoneySend is a trademark of MasterCard International Incorporated

FIG. 39

Bank Logo MasterCard Money Send

Home | Contact Us | FAQ

Sign Out | Send | Estimate | My Account

Pre-Send Confirmation

Deduct from my Funding Account Number XXXX XXXX XXXX 4544

Receiver Details

***Mandatory input**

First Name*	<input type="text" value="Maria"/>	City*	<input type="text" value="Jakarta"/>
Middle Initial	<input type="text" value="J"/>	State	<input type="text"/>
Last Name*	<input type="text" value="Smith"/>	Country*	<input type="text" value="Indonesia"/>
Receiver Description*	<input type="text" value="Mother"/>	Postal Code*	<input type="text" value="455533"/>
Address*	<input type="text" value="23, Jln. Sudirman"/>	Email	<input type="text" value="maria.smith@hotmail.com"/>
		Mobile No.	<input type="text" value="65-Singapore"/> <input type="text" value="81678888s"/>

Transaction Details

***Mandatory input**

You are sending money from your singapore SGD Funding to your Indonesia IDR Receiver Account

Transfer Amount*	<input type="text" value="SGD"/>	<input type="text" value="101.62"/>
Receive Amount*	<input type="text" value="IDR"/>	<input type="text" value="100000"/>
Service Fees	<input type="text" value="SGD"/>	<input type="text" value="4.00"/>
Total Payable	<input type="text" value="SGD"/>	<input type="text" value="105.62"/>

I have read and I accept the Terms & Conditions.

MasterCard MoneySend is a trademark of MasterCard International Incorporated

4002

FIG. 40

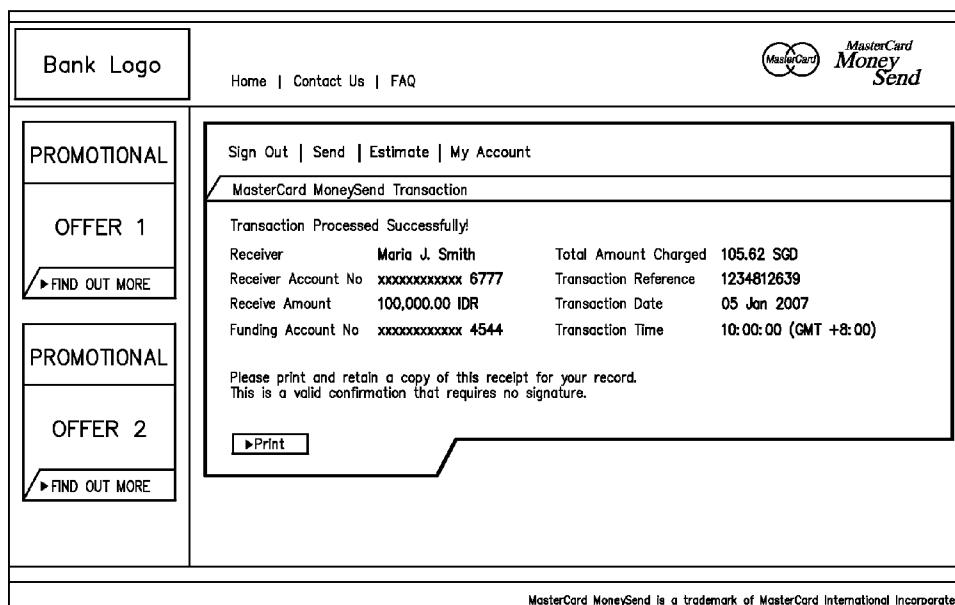

FIG. 41

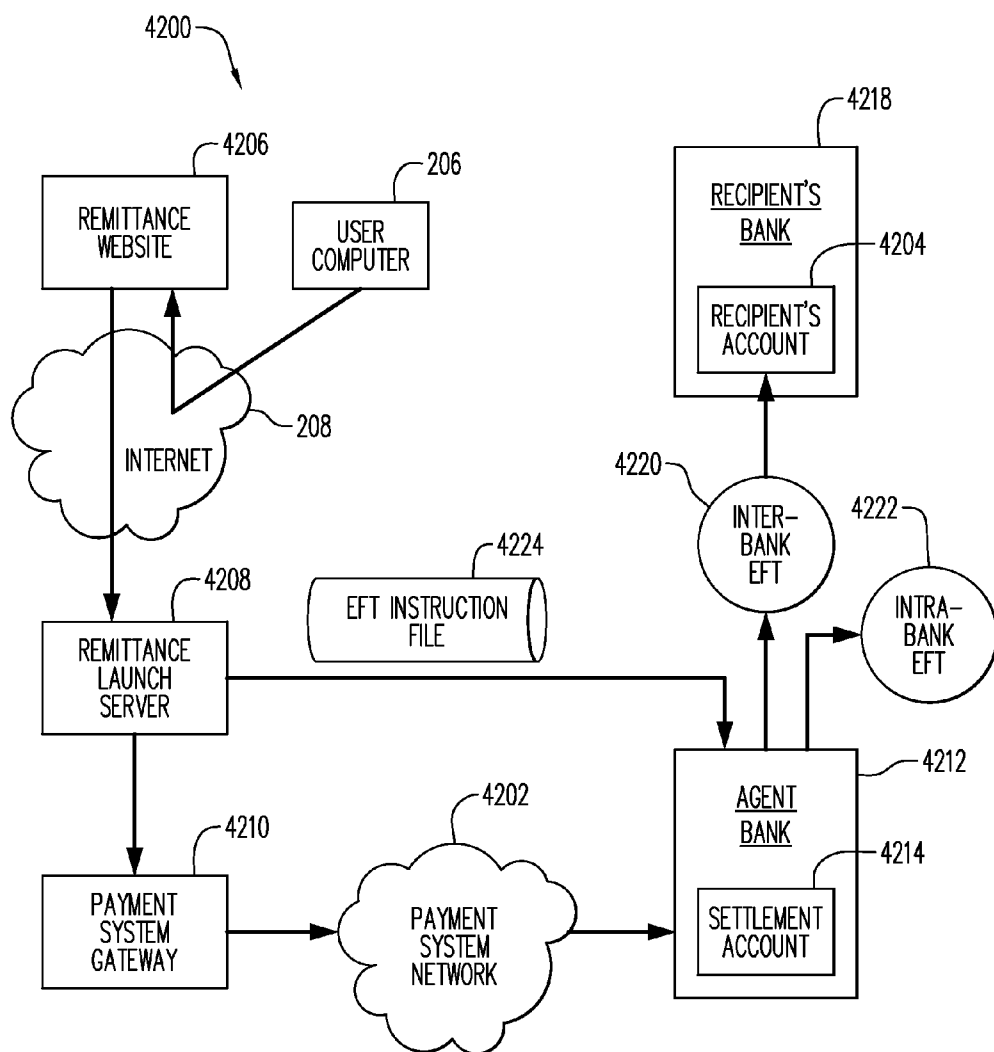

FIG. 42

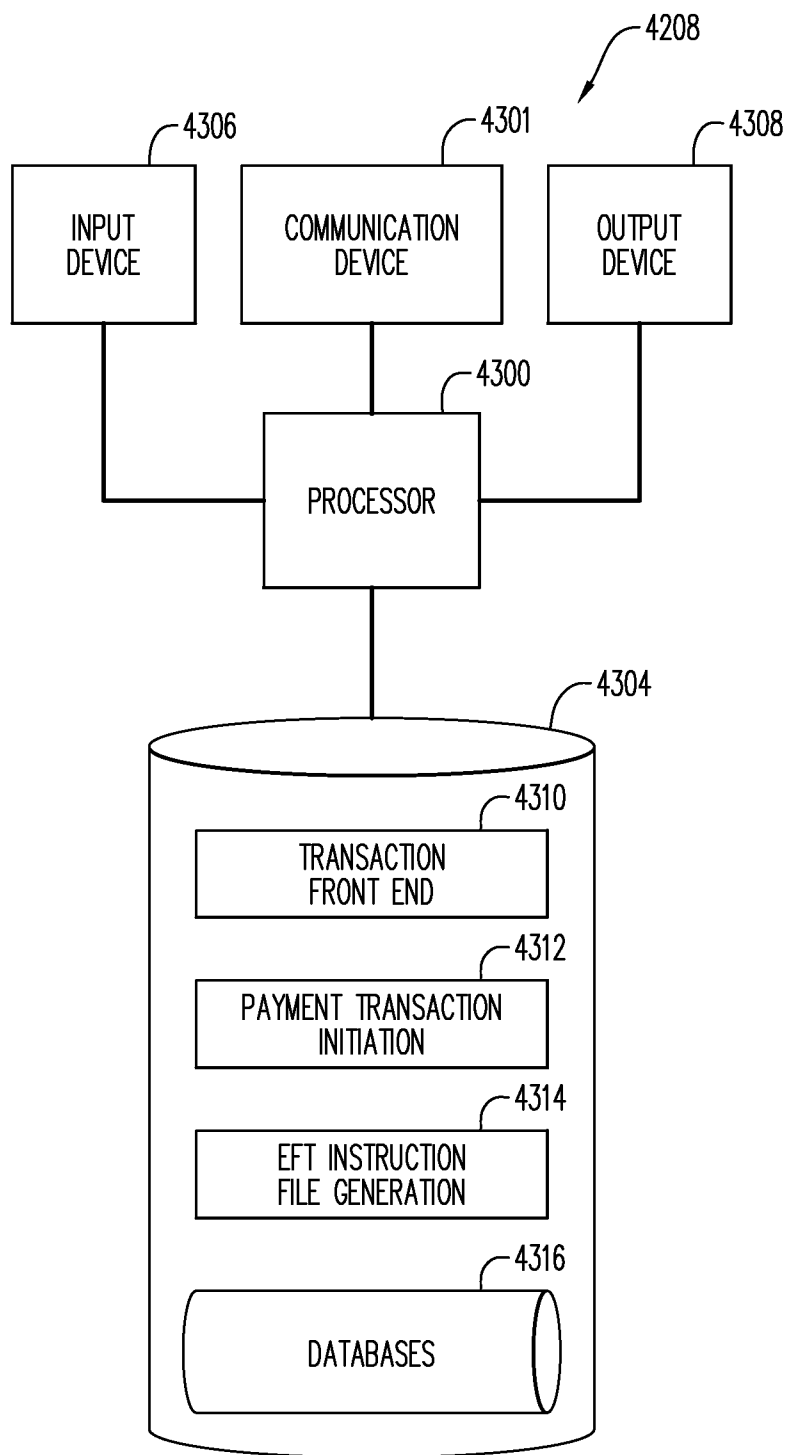

FIG. 43

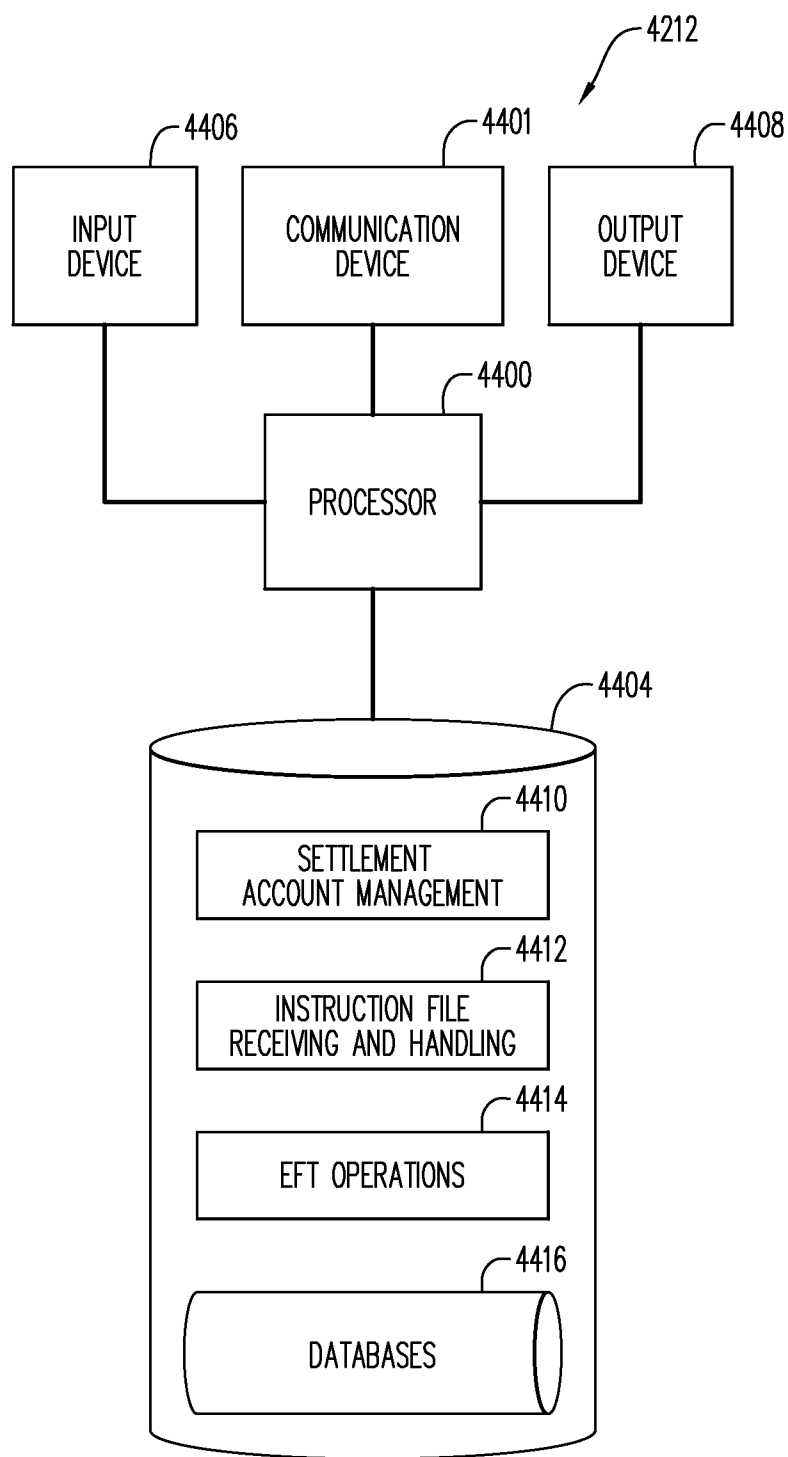

FIG. 44

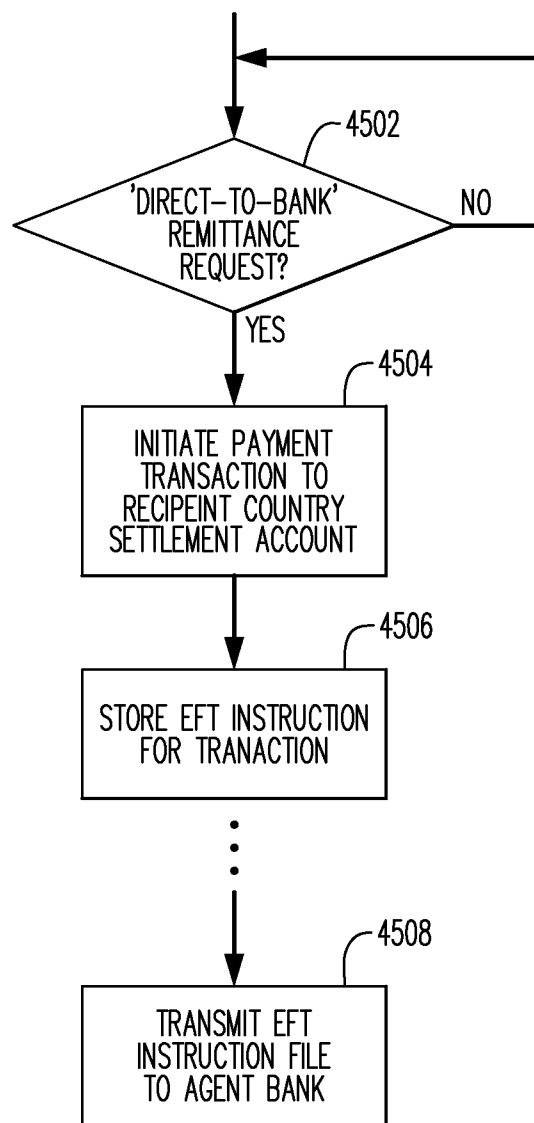

FIG. 45

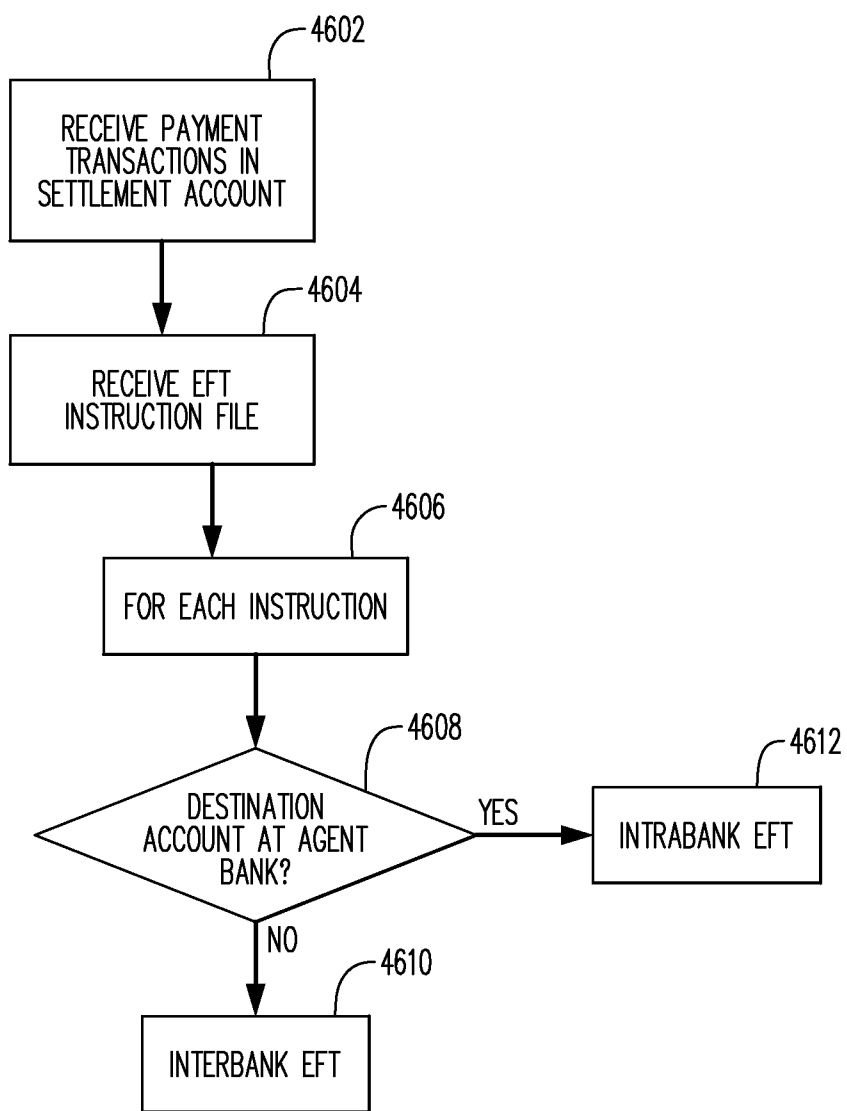

FIG. 46

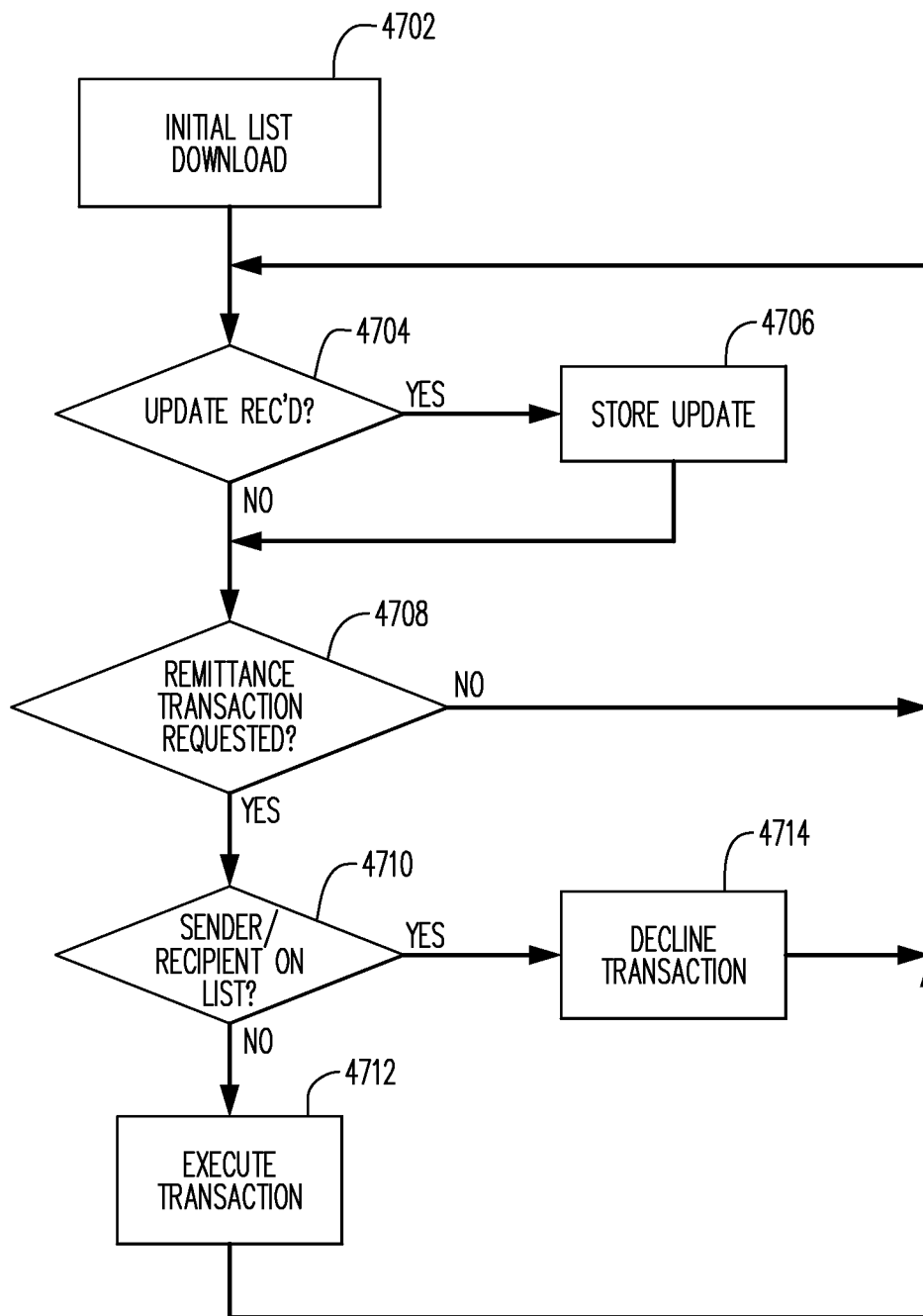

FIG. 47

METHODS AND APPARATUS FOR FUNDS REMITTANCES TO NON-PAYMENT CARD ACCOUNTS USING PAYMENT CARD SYSTEM

CROSS-REFERENCE TO RELATED APPLICATION

[0001] This application is a continuation application of U.S. patent application Ser. No. 11/951,043 filed on Dec. 5, 2007, which claims the benefit of U.S. Provisional Patent Application No. 60/910,550, filed on Apr. 6, 2007, which applications are incorporated herein by reference.

BACKGROUND

[0002] Embodiments disclosed herein relate to remittance systems. In particular, some embodiments relate to methods, apparatus, systems, means and computer program products for implementing a remittance system on the basis of an international payment card system.

[0003] Many individuals regularly send money to family or friends across international borders. The total annual volume of international person-to-person remittances is measured in the hundreds of billions of U.S. dollars (including transactions that involve U.S. dollars and transactions that do not involve U.S. dollars) and is increasing from year to year.

[0004] Formal commercial remittance channels are generally labor-intensive and expensive to use. Informal channels for remittances are also labor-intensive and may not provide adequate protection for the funds remitted. Many of the people who make or receive international remittances are not wealthy and can ill-afford the costs and risks presented by conventional remittance channels.

[0005] More generally, senders and recipients of remittances frequently find conventional remittance channels to be time-consuming and inconvenient. It is not unusual for the sender to be required to bring cash to a store operated by a remittance services provider (RSP). Accordingly, the sender is constrained to accommodate himself or herself to the store's operating hours, must carry cash on his or her person, and may have to wait in line or otherwise experience poor service at the RSP's store. The recipient also may be required to pick up the remitted funds at an RSP's store, thereby possibly suffering the same disadvantages and inconveniences that the sender was subject to.

[0006] International remittances also raise issues related to governmental security and anti-crime interests. In many countries, regulations are in place with respect to international transfers of funds, to aid in efforts to combat funding of terrorist groups and organized crime. There are also international initiatives in these areas. These types of regulations are generally referred to as "anti-money laundering" (AML) provisions, and typically require that financial institutions and RSPs "know your customer" (KYC). Compliance with KYC and AML regulations may place significant cost and administrative burdens on formal international remittance channels. Of course, these costs are passed on to the users of the remittance channels.

[0007] In U.S. patent application Ser. No. 11/836,984 (which has a common inventor herewith, and which is incorporated herein by reference), an international remittance system was proposed that is based on an international payment card system such as that operated by MasterCard International Inc. (the assignee hereof) and its member financial

institutions. Aspects of the present disclosure extend the benefits of such a system to remittance recipients who do not have payment card accounts.

[0008] The present disclosure, in other aspects, addresses issues that may arise related to encouraging participation by payment card account issuing financial institutions in an international remittance system. In particular, the present disclosure proposes web-based software tools that make it convenient for participating financial institutions to perform administrative tasks involved in implementing policy decisions related to participation in such a remittance system.

BRIEF DESCRIPTION OF THE DRAWINGS

[0009] Features and advantages of some embodiments of the present invention, and the manner in which the same are accomplished, will become more readily apparent upon consideration of the following detailed description of the invention taken in conjunction with the accompanying drawings, which illustrate preferred and exemplary embodiments and which are not necessarily drawn to scale, wherein:

[0010] FIG. 1 is a block diagram that illustrates an international remittance system provided according to some aspects of the present invention.

[0011] FIG. 2 is a block diagram that illustrates a system of computers operated in connection with administrative aspects and other aspects of the remittance system of FIG. 1 and provided according to other aspects of the present invention.

[0012] FIG. 3 is a block diagram that illustrates an embodiment of a server computer that may be part of the system of FIG. 2.

[0013] FIG. 4 is a block diagram that illustrates an embodiment of another server computer that may be part of the system of FIG. 2.

[0014] FIGS. 5-9 are screen displays that may be provided by the server computer of FIG. 3 to aid in administrative set-up procedures performed by a financial institution which participates in an international remittance system.

[0015] FIG. 10 is a flow chart that illustrates an administrative set-up procedure that may be performed by a financial institution which participates in an international remittance system.

[0016] FIGS. 11-14 are screen displays that may be provided by the server computer of FIG. 3 in conjunction with the procedure illustrated by FIG. 10.

[0017] FIG. 15 is a flow chart that illustrates another administrative set-up procedure that may be performed by a financial institution which participates in an international remittance system.

[0018] FIGS. 16-24 are screen displays that may be provided by the server computer of FIG. 3 in conjunction with the procedure illustrated by FIG. 15.

[0019] FIGS. 25-30 are screen displays that may be provided by one or more computers included in the system of FIG. 2 in connection with other administrative aspects of an international remittance system.

[0020] FIGS. 31-41 are screen displays presented in the system of FIGS. 1 and/or 2 to a customer who wishes to make remittances using the international remittance system.

[0021] FIG. 42 is a block diagram that illustrates a system in which an international payment card system is used to make remittances into bank accounts that are not payment card accounts.

[0022] FIG. 43 is a block diagram that illustrates a server computer that is included in the system of FIG. 42 for initiating funds transfers.

[0023] FIG. 44 is a block diagram that illustrates a computer that receives and/or relays funds transfers in the system of FIG. 42.

[0024] FIG. 45 is a flow chart that illustrates a process that may be performed by the computer of FIG. 43.

[0025] FIG. 46 is a flow chart that illustrates a process that may be performed by the computer of FIG. 44.

[0026] FIG. 47 is a flow chart that illustrates a process that may be performed by a financial institution computer in the system of FIGS. 1 and/or 2.

DETAILED DESCRIPTION

[0027] In general, and for the purpose of introducing concepts of embodiments of the present invention, an international remittance system is based on a payment card system such as that operated by MasterCard International Inc., the assignee hereof. Remittances are transferred and cleared from senders' payment card accounts to recipients' payment card accounts or to recipients' accounts that are not payment card accounts. Financial institutions are the issuers of the payment card accounts and handle compliance with KYC/AML regulations.

[0028] In some embodiments, web-based tools provide a convenient vehicle for participating financial institutions to implement policy decisions concerning, e.g., the levels of service fees and/or foreign exchange fees to be charged in connection with remittances.

[0029] Remittance systems such as those described herein may leverage existing payment systems to provide previously unavailable efficiencies, cost-effectiveness and convenience, while also facilitating regulatory compliance by participating financial institutions (FIs).

[0030] FIG. 1 is a block diagram that illustrates an international remittance system 100 provided according to some aspects of the present invention.

[0031] At the heart of the remittance system 100 is a payment system 102. As will be seen, the payment system 102 operates to route and clear funds transfers from the payment card accounts of senders to the payment card accounts or other accounts of recipients. One example of a suitable payment system is the Banknet system, which is well-known to those who are skilled in the art, and which is operated by the assignee hereof.

[0032] A major strength of a payment system such as the Banknet system is that it interlinks numerous financial institutions around the world. In practice the remittance system 100 may include many financial institutions that act as issuers of payment card accounts, but for purposes of illustration only two such FIs are shown in FIG. 1, namely the financial institution (sending FI 104) that issued the payment card account of the sender of a remittance, and the financial institution (receiving FI 106) that issued the payment card account of the recipient of the remittance. (As discussed below in connection with FIG. 42, in an alternative embodiment, at least some of the recipients' accounts need not be payment card accounts.) As indicated respectively at 108 and 110, the sending FI 104 and the receiving FI 106 are both connected by suitable data communication paths to the payment system 102. It may be assumed that the receiving FI 106 is located in

a different country from FI 104 so that any remittance transmitted between the two FIs 104, 106 is an international remittance.

[0033] It may also be assumed that the FIs 104, 106, and the other FIs included in the remittance system 100 but not depicted in the drawings, are banks or other organizations that are subject to regulation to assure compliance with KYC and AML requirements. It may also be assumed that the FIs have internal procedures in place to comply with KYC and AML requirements. Consequently, upon or prior to opening a payment card account for a customer, each FI gathers information about the customer, such as the customer's full name, and residential address. Customary procedures may also call for the FI to obtain documentary proof of the customer information. The documentary proof may be a driver's license, a passport, an identity card, etc. To demonstrate compliance with the documentation procedures, the FI may also keep an image of the document(s) used to establish the customer's identity and address.

[0034] Continuing with the concept that FIG. 1 shows components of the remittance system 100 with respect to a single remittance transaction, block 114 represents a mechanism by which the sender initiates a funds transfer. The mechanism 114, from which the funds transfer originates, may come in a number of different forms, such as the sender's mobile telephone, an automatic teller machine (ATM), or a personal computer or other web-browsing device (from which the sender may access a website maintained by or on behalf of the sending FI 104). As another alternative, the sender may visit a bank branch to initiate the funds transfer, and may speak with an employee of the sending FI 104. In response to the sender's request, the sending FI employee may operate a personal computer or terminal to launch the funds transfer.

[0035] Also shown in FIG. 1 (in phantom) is a mechanism 116 that may be utilized by the receiving FI 106 to notify that recipient that the funds transfer has taken place. The notification mechanism may be the recipient's mobile telephone, to which the receiving FI may send a text message or automated telephone call. Other possible embodiments of the notification mechanism may include the recipient's home personal computer (by e-mail) or a pager.

[0036] FIG. 2 is a block diagram that illustrates a system 200 of computers operated in connection with administrative aspects and other aspects of the remittance system 100 of FIG. 1 and provided according to other aspects of the present invention. The main focus of the computer capabilities of FIG. 2 is in connection with set-up and transaction handling at the sending side of an international remittance system such as that illustrated in FIG. 1.

[0037] The system 200 may include a number of computers 202 that are operated by or on behalf of financial institutions in connection with the sending of domestic and/or international remittances. Thus, any one or more of the computers 202 may serve the role represented by block 104 (sending FI) in FIG. 1. The number of computers 202 may be large, in that at least one such computer may be operated by or on behalf of each financial institution that participates as a sending FI in a remittance system.

[0038] In addition, the system 200 may include a server computer 204 that provides one or more web-based tools for use by sending financial institutions in implementing remittance services for the customers of the sending FIs. As will be seen, in some embodiments, the tools provided by the server

computer 204 may aid in set-up operations for service fees and in other administrative functions which a sending FI may need to engage in.

[0039] Still further, the system 200 may include a number of user computers 206. As will be seen, the user computers may be operated by individual customers who wish to make remittances and may be used by the individuals to access remittance services offered by sending FIs. In general, each individual customer may have, or wish to establish, a banking relationship with one of the sending FIs referred to above.

[0040] Another class of user computers 206 (not separately indicated) may be operated by administrative personnel who are employed by sending FIs. User computers of this class may be operated to access the server computer 204 and/or for other purposes related to the system 200.

[0041] The system 200 may also encompass a data communication network 208. The data communication network 208 may be formed partly or entirely by a public network such as the Internet, and/or may be at least partly constituted by private data communication channels. The data communication network 208 may operate to allow one or more of the other components of the system 200 to communicate with one or more other components of the system 200. For example, data communication over the network 208 may take place between the sending FI computers 202 and the administrative set-up computer 204 and between the user computers 206 and the sending FI computers 202.

[0042] Various administrative software tools described below may be hosted at and accessed via the administrative set-up server computer 204 or alternatively may be downloaded from the administrative set-up server computer 204 to one or more of the FI remittance host computers 202 and downloaded from and accessed via the FI remittance host computers 202. Alternatively, administrative settings set-up in the administrative set-up server computer 204 may be downloaded therefrom to an FI remittance host computer 202 to control operation of the FI remittance host computer 202. Terminals and/or personal computers operated by FI personnel may interact with either or both of the FI's respective host computer 202 and the administrative set-up server computer 204. The FI functions and/or set-up functions described herein may be divided in any convenient manner between an FI's host computer 202 and the administrative set-up server computer 204. Moreover the computer 204 may be combined with at least one of the computers 202.

[0043] FIG. 3 is a block diagram that illustrates an embodiment of the server computer 204.

[0044] The server computer 204 may be conventional in its hardware aspects but may be controlled by software to cause it to operate in accordance with aspects of the present invention.

[0045] The server computer 204 may include a computer processor 300 operatively coupled to a communication device 301, a storage device 304, an input device 306 and an output device 308.

[0046] The computer processor 300 may be constituted by one or more conventional processors. Processor 300 operates to execute processor-executable steps, contained in program instructions described below, so as to control the server computer 204 to provide desired functionality.

[0047] Communication device 301 may be used to facilitate communication with, for example, other devices (such as the other computers shown in FIG. 2).

[0048] Input device 306 may comprise one or more of any type of peripheral device typically used to input data into a computer. For example, the input device 306 may include a keyboard and a mouse. Output device 308 may comprise, for example, a display and/or a printer.

[0049] Storage device 304 may comprise any appropriate information storage device, including combinations of magnetic storage devices (e.g., magnetic tape and hard disk drives), optical storage devices such as CDs and/or DVDs, and/or semiconductor memory devices such as Random Access Memory (RAM) devices and Read Only Memory (ROM) devices, as well as so-called flash memory.

[0050] Storage device 304 stores one or more programs for controlling processor 300. The programs comprise program instructions that contain processor-executable process steps of server computer 204, including, in some cases, process steps that constitute processes provided in accordance with principles of the present invention, as described in more detail below.

[0051] The programs may include an application/program module 310 that allows FI administrative personnel to set up profiles that are to be stored in the server computer 204 and/or in a respective one of the FI computers 202 in regard to service fees and/or foreign exchange conversion fees to be charged by the FI in question for remittance services. The programs may also include an application/program module 312 that allows FI administrative personnel to establish various rules for remittance transactions. Such rules may include assignment of fee profiles to certain classes of remittance transactions.

[0052] Still another application/program module 314 stored on the storage device 304 may aid FI administrative personnel in managing and tracking approval at higher levels of rules proposed by lower level administrative personnel. Further applications/program modules 316 and 318, also stored on the storage device 304, may be useful, respectively, for performing miscellaneous administrative tasks and for implementing data queries or reports regarding remittance activities by an FI. As indicated at 320, the storage device 304 may store one or more databases of information relevant to remittance activities.

[0053] In addition to the software programs expressly listed above, the server computer 204 may be programmed with other software, such as one or more operating systems, device drivers, database management programs, programs to enable the server computer 204 to perform web hosting functions, etc.

[0054] FIG. 4 is a block diagram representation of a typical one of the sending FI computers 202 shown in FIG. 2.

[0055] In its hardware aspects, the computer 202 may be conventional, and similar to the hardware components described above in connection with the server computer 204. The hardware aspects of the computer 202 will therefore not be further described, except to mention that the computer 202 may include a processor 400 in communication with a communication device 401, a storage device 404, an input device 406, and an output device 408.

[0056] The storage device 404 may store an application program 410 that allows prospective senders of remittances to establish user accounts with respect to the FI's remittance services. A further application program 412, also stored on the storage device 404, may operate to handle particular remittance transactions. Still another application program 414, also stored on the storage device 404, may allow for

modification and management of user accounts. Further, one or more databases **416** stored on the storage device **404** may contain data relating to remittance transactions, user accounts, etc.

[0057] In addition to the software programs expressly listed above, the computer **202** may be programmed with other software, such as one or more operating systems, device drivers, database management programs, programs to enable the computer **202** to perform web hosting functions, etc.

[0058] Each of the user computers **206** may be a personal computer or other computing device (including, e.g., a mobile telephone), and may include conventional components such as a CPU, a display, a keyboard and a mouse.

[0059] FIG. **5** shows a sign-in screen display that may be accessed by an administrative employee of an FI in connection with the system of FIG. **2**. As is also the case with the screen displays shown in FIGS. **5A-9**, **11-14** and **16-30**, the screen display of FIG. **5** may be downloaded from computer **204** or from one of the computers **202** in FIG. **2**, and displayed on the display screen of a personal computer or terminal operated by the administrative employee and in communication with the computer **204** or **202**. At the data entry fields **502**, **504** in FIG. **5**, the administrative employee may enter his/her user ID and PIN, respectively. Upon verification of the user ID and PIN, the screen display shown in FIG. **5A** is presented. This screen display is a main menu page, and includes pull down menus **510** ("Setup"), **512** ("Rules"), **514** ("Review"), **516** ("Admin") and **518** ("Reports & Queries").

[0060] Upon pulling down the menu **510**, the user sees the menu options "Acquirer Profile", "Sending Issuers", "Receiving Issuers", "Sending Countries" and "Receiving Countries". If the user selects the "Acquirer Profile" menu option, then the display screen shown in FIG. **6** is provided. The display screen of FIG. **6** is a data entry screen by which the user may define a profile for the sending FI with respect to the payment-card-based remittance system. In the upper region **602** of the data entry screen of FIG. **6**, the user may enter information such as the FI's name, country of registration, address, ICA and BIN numbers, and contact information. In a lower region **604** of the data entry screen the user may enter transaction limit(s) that may apply across all transactions initiated in the remittance system by the FI.

[0061] If the user selects the "Sending Issuers" menu option from pull down menu **510**, then the screen display shown in FIG. **7** is provided. The screen display of FIG. **7** allows the user to select from among FIs that issue payment card accounts. Selection of one of those issuers in FIG. **7** means that the FI engaged in the setup procedure is enabled to initiate remittance transactions to be funded from payment card accounts issued by the selected issuers. At **702** in FIG. **7** there is a data display field that lists the payment card issuers that are available for selection. Data display field **704** lists (none shown in FIG. **7**) issuers that have been selected. Select/de-select buttons **706** may be actuated by the user to add or remove issuers to/from the "selected" list shown in field **704**.

[0062] If the user selects the "Receiving Issuers" menu option from pull down menu **510**, then a screen display similar in format to FIG. **7** is shown. The "Receiving Issuers" screen display (not shown) allows the user to select from among available issuers, where selection of such an issuer enables the FI engaged in the setup procedure to send remittances to the selected issuer.

[0063] If the user selects the "Sending Countries" menu option from pull down menu **510**, then the screen display

shown in FIG. **8** is provided. In the screen display of FIG. **8**, there may be a pull down menu **802**, from which the user may select a country from which the FI may initiate remittance transactions (in some embodiments there may be only one such country). For the selected "sending country" the user may enter, in one or more of the data entry fields **804**, **806**, **808**, **810**, codes that represent the currencies that the remittance sender may use to fund remittance transactions.

[0064] If the user selects the "Receiving Countries" menu option from pull down menu **510**, then the screen display shown in FIG. **9** is provided. In the screen display of FIG. **9**, there may be a column **902** of pull down menus. Each of the pull down menus in column **902** may be used to select a respective country. Selection of a country from one of the menus in column **902** indicates that the FI is enabled to send remittances to the selected country. For each of the pull down menus in FIG. **9**, there is a row of data entry fields in which the user may enter codes to represent currencies in which remittances may be disbursed in the respective selected country.

[0065] Upon pulling down the "Rules" menu **512** (FIG. **5A**), the user sees the menu options "Service Fees Profile Setup", "Service Fees Profile Assignment", "Forex Markup Profile Setup", "Forex Markup Profile Assignment", "Transaction Limits Profile Setup" and "Transaction Limits Profile Assignment". (As will be appreciated by those who are skilled in the art, "Forex" stands for "foreign exchange", and a "Forex Markup" is a service fee charged for converting one currency to another.)

[0066] If the user selects the "Service Fees Profile Setup" option from the menu **512**, then the process illustrated by the flow chart in FIG. **10** is launched. (This process may be implemented with software on one or both of the server computer **204** or the respective FI's computer **202**.)

[0067] Referring then to FIG. **10**, at **1002** in FIG. **10** it is determined whether the user has opted to define a fee profile. If so, then step **1004** follows. At **1004**, a data entry page screen display as shown in FIG. **11** is provided. Referring to FIG. **11**, the screen display includes an upper portion **1102** and a lower portion **1104**.

[0068] The upper portion **1102** of the screen display may have several radio buttons, of which the user may select one to select a name or other designation for the fee profile to be defined by entering data in the lower portion **1104**. Thus, the lower portion **1104** is for the user to enter data for defining the fee profile designated in the upper portion **1102**.

[0069] If the user actuates the "Add New" button **1106** in the upper portion **1102**, then a data entry field (not shown) is added to the lower portion **1104**. This additional data entry field may be used to enter a name or designation for a new profile to be defined with data entry in the lower portion **1104**. In this situation, there may also be a pull down menu or the like (not shown) from which to select a code to designate the currency in which the fees are to be denominated.

[0070] Designation of the fee profile to be defined, whether by radio button or data entry of a new designation, is indicated at **1006** in FIG. **10**

[0071] Referring again to FIG. **11**, the lower portion **1104** of the screen display may include four columns of data entry fields, namely, as referenced in FIG. **11**, columns **1108**, **1110**, **1112** and **1114**. The data entry fields of the columns **1108**, **1110**, **1112** and **1114** are also arranged in rows, with each of the rows corresponding to a respective tier of the service fee structure that is to be defined. In each row, the data (if any) displayed in the first column **1108** corresponds to the tier start

amount, and the data displayed in the second column **1110** corresponds to the tier end amount. The data in the third column **1112** indicates the amount of service fee applicable to the tier in question, and the data in the fourth column **1114** indicates the percentage service fee applicable to the tier in question, over and above any flat amount fee indicated in the fourth column **1114**.

[0072] Returning now to FIG. **10**, following step **1006** is a decision block **1008**. At **1008**, it is determined whether the user has entered (e.g., via the keyboard of his/her personal computer/terminal) a numerical amount in a data entry field in the second column **1110**. If so, then step **1010** follows decision block **1008**. At step **1010**, the display is updated in the data entry field to reflect the numerical amount that was entered, and in addition the data entry field in the next row and in the first column **1108** is automatically populated with the amount that was just entered in the second column **1110** in the row above the next row. An example of this is shown in FIG. **12**. Specifically (and in comparison to FIG. **11**), the data entry field in the first row and in the second column **1110** has received data entry to define the tier end amount for the first tier as **250** Singapore dollars, as indicated at **1202** in FIG. **12**. In addition, the data field in the second row and in the first column **1108** has been automatically populated to define the tier start amount for the second row (corresponding to the second tier of the fee structure) as **250** Singapore dollars, as indicated at **1204** in FIG. **12**.

[0073] A further tier end amount update/next tier start amount population is illustrated in FIG. **13** (in comparison to FIG. **12**). As seen from FIG. **13**, the data entry field in the second row and in the second column **1110** has received data entry to define the tier end amount for the second tier as **500** Singapore dollars, as indicated at **1302** in FIG. **13**. Also, the data field in the third row and in the first column **1108** has been automatically populated to define the tier start amount for the third row (corresponding to the third tier of the fee structure) as **500** Singapore dollars, as indicated at **1304** in FIG. **13**.

[0074] A data entry update for the third tier end amount and automatic population for the fourth tier start amount data field are illustrated respectively at **1402** and **1404** in FIG. **14**.

[0075] If no tier end amount data entry occurs at **1008**, then another decision block **1012** follows decision block **1008**. (Alternatively, if a tier end amount data entry did occur at **1008**, then decision block **1012** follows step **1010**.) At decision block **1012**, it is determined whether the user has entered (e.g., via the keyboard of his/her personal computer/terminal) a numerical amount in a data entry field in the third column **1112**. If so, then step **1014** follows decision block **1012**. At step **1014**, the data entry field in question is updated to reflect the data entry, and the corresponding currency amount is assigned as a flat amount service fee to the tier defined by the tier start amount and the tier end amounts indicated in the same row (in the first column **1108** and the second column **1110**, respectively). A change/update to the service fee amount for the first tier of the fee structure is indicated by comparing data field **1306** as seen in FIG. **13** with data field **1306** as seen in FIG. **14**. Similar changes may of course be made in other rows in the third column **1112** and/or to add or change a percentage based service fee by data entry in the fourth column **1114**.

[0076] If no fee level data entry occurs at **1012**, then another decision block **1016** follows decision block **1012**. (Alternatively, if a fee level data entry did occur at **1012**, then decision

block **1016** follows step **1014**.) At decision block **1016**, it is determined whether the user has indicated that he/she has completed entering or editing the designated profile. The user may indicate that he/she has completed entering or editing the profile by actuating the “Proceed” button (reference numeral **1406** in FIG. **14**). If the user so indicates, a positive determination is made at decision block **1016**, and step **1018** then follows decision block **1016**. At step **1018**, the service fee profile defined by the data entered at **1008**, **1012** is stored, for future assignment to certain classes of remittance transactions, as will be described below.

[0077] If a negative determination is made at decision block **1016** (i.e., if the user has not indicated that he/she has completed data entry for the fee profile), then the process of FIG. **10** loops back to decision block **1008** and decision block **1012**, to allow for multiple iterations of entering tier end amounts and fee level amounts.

[0078] Although not expressly indicated in FIG. **10**, the user may also escape from the process of FIG. **10**, without causing the entered data to be stored, by actuating the “Cancel” button **1408** shown in FIG. **14**.

[0079] Considering again the “Rules” menu **512** (FIG. **5A**), if the user selects the “Service Fees Profile Assignment” option from the menu **512**, then the process illustrated by the flow chart in FIG. **15** is launched. (This process may be implemented with software on one or both of the server computer **204** or the respective FI’s computer **202**.)

[0080] Referring then to FIG. **15**, at **1502** in FIG. **15** it is determined whether the user has opted to assign a fee profile to a class of remittance transactions. If so, then step **1504** follows. At **1504**, a data entry page screen display as shown in FIG. **16** is provided. Referring to FIG. **16**, the screen display includes an upper portion **1602** and a lower portion **1604**. In contrast to much of the data entry described with reference to FIGS. **10-14**, most if not all of the data entry performed in the process of FIG. **15** (and performed with use of the data entry screen display of FIG. **16**) may be accomplished by interaction with pull down menus. The screen display shown in FIG. **16** includes, in the upper portion **1602**, four pull down menus **1606**, **1608**, **1610** and **1612** for defining a class of remittance transactions to which a service fee profile is to be assigned. The class of transactions may be defined in terms of (a) the country from which the remittance is sent (“sender country”), (b) the currency in which the remittance is funded (“sender currency”), (c) the country to which the remittance is sent (“recipient country”), and (d) the currency in which the remittance is disbursed (“recipient currency”). These four parameters may be considered to define a currency remittance channel. The pull down menu **1606** may be employed to select the sender country (although, in some embodiments, the pull down menu **1606** may contain only one option, in that the FI in question may originate remittance transactions from only one country—its country of operation). The pull down menu **1608** may be employed to select the sender currency. The pull down menu **1610** may be employed to select the recipient country. The pull down menu **1612** may be employed to select the recipient currency.

[0081] It will be recognized that defining a currency remittance channel inherently includes selecting a pair of currencies, namely the sender currency and the recipient currency.

[0082] Continuing to refer to FIG. **16**, the lower portion **1604** of the screen display includes a pull down menu **1614**, which may be used to select a previously stored service fee

profile for assignment to the currency remittance channel defined with the pull down menus **1606-1612**.

[0083] Referring once more to FIG. **15**, following step **1504** is step **1506**. At step **1506**, a currency remittance channel is defined, by the user interacting with the pull down menus **1606-1612** to select the four parameters for the currency remittance channel. (As noted before, the first parameter—the sender country—may be fixed.) FIG. **17** is a screen display that shows a currency remittance channel that has been selected. In the example screen display of FIG. **17**, the sender country is Singapore, the sender currency is Singapore dollars, the recipient country is Indonesia, and the recipient currency is U.S. dollars.

[0084] Referring yet again to FIG. **15**, step **1508** follows step **1506**. At step **1508**, the user selects a service fee profile by interacting with the pull down menu **1614**. FIG. **18** is a screen display that shows that a certain service fee profile (in this example, the profile previously designated as “Profile 1”) has been selected from the pull down menu **1614**. Next, at step **1510** in FIG. **15**, the user may assign the selected service fee profile to the currently defined currency remittance channel by actuating the “Assign” button shown at **1802** in FIG. **18**. FIG. **19** is the screen display that is presented upon actuation of the “Assign” button (seen in FIG. **18**, not included in the screen display of FIG. **19**). In FIG. **19**, the grid of data display fields in the lower portion of the screen display is employed to present to the user the fee structure defined in the selected and assigned service fee profile. With the fee structure in front of him/her, the user may confirm the assignment of the fee profile to the currency remittance channel by actuating the “Proceed” button **1902**. Another button, which is not shown in FIG. **19**, may also be present to allow the user to go back to an earlier screen in order to select a different fee profile for assignment to the currency remittance channel.

[0085] In some embodiments, the assignment of the fee profile to the currency remittance channel may be tentative or provisional in the sense that it may require approval from a higher level manager within the FI.

[0086] Considering again the “Rules” menu **512** (FIG. **5A**), if the user selects the “Forex Markup Profile Setup” option from the menu **512**, then a process similar to that of FIG. **10** is launched and a data entry screen display as in FIG. **20** is provided. Data entry for defining a foreign exchange conversion fee profile may be performed by interaction with the data entry screen display of FIG. **20** and in a similar manner to the service fee profile definition process described above with reference to FIGS. **10-14**. In view of the above explanation of FIGS. **10-14** and the similar operability of FIG. **20** in comparison with FIG. **11**, those of ordinary skill in the art will not require a further explanation of FIG. **20** and the associated process for defining a foreign exchange conversion fee profile.

[0087] Again with regard to the “Rules” menu **512**, if the user selects the “Forex Markup Profile Assignment” option from menu **512**, then a process similar to that of FIG. **15** is launched and a data entry screen display as in FIG. **21** is provided. Data entry for assigning a foreign exchange conversion fee profile to a class of transactions may be performed by interaction with the data entry screen display of FIG. **21** and in a similar manner to the service fee profile assignment process described above with reference to FIGS. **15-19**. One difference between the foreign exchange conversion fee profile assignment process and the service fee profile assignment process is that the former may only require selection of two

currencies (the sender currency and the recipient currency) where as the latter also may require selection of the sender country and the recipient country. Otherwise, the similarity between the two profile assignment processes is such that FIG. **21**, taken with the above discussion of FIGS. **15-19**, is sufficient to make the foreign exchange conversion fee profile assignment process understood by those who are skilled in the art.

[0088] Referring once more to the “Rules” menu **512**, if the user selects the “Transaction Limits Profile Setup” option from menu **512**, then a data entry screen display as in FIG. **22** is provided. It will be noted that an upper portion **2202** in FIG. **22** allows for designation of a new transaction limits profile to be defined or an existing transaction limits profile to be edited. A lower portion **2204** of FIG. **22** mainly comprises a grid of data entry fields that the user may employ to enter limits on transactions in a number of different currencies. The limits may be defined in terms of a maximum number of transactions per day, maximum currency amount per transaction and/or maximum cumulative transaction amounts over one or more periods of time.

[0089] Again with respect to the “Rules” menu **512**, if the user selects the “Transaction Limits Profile Assignment” option from menu **512**, then a data entry screen display as in FIG. **23** is provided. An upper portion **2302** of the screen display of FIG. **23** includes one or more data entry fields and/or pull down menus that the user may employ to identify a customer or class of customers to which a transaction limits profile is to be assigned. The lower portion **2304** of the screen display of FIG. **23** may include a pull down menu **2306** by which the user may select a previously stored transaction limits profile to be assigned to the customer(s) or class(es) of customers defined in the upper portion of the screen display. **[0090]** Upon pulling down the “Review” menu **514** (FIG. **5A**), the user sees the menu options “Pending Requests”, “Approved Requests”, “Rejected Requests” and “Suspect Customers”. If the user selects the “Pending Requests” option, then a screen display as shown in FIG. **24** may be provided. The user may select one of the radio buttons in FIG. **24** and then click “Proceed” to call up a report of (a) service fee profile assignments awaiting higher level approval, (b) foreign exchange conversion fee profile assignments awaiting higher level approval, or (c) transaction limits profile assignments awaiting higher level approval. Thus the display screen of FIG. **24** may be useful to the user in managing the approval process for profile assignments.

[0091] If the user selects the “Approved Requests” or “Rejected Requests” options in menu **514** he/she may be provided with a screen display similar to FIG. **24**, for allowing the user to call up reports concerning approved or rejected profile assignments.

[0092] “If the user selects the “Suspect Customers” option in menu **514**, then a screen display like FIG. **25** may be provided. The screen display of FIG. **25** may present a report that individually lists customers who have apparently come up on anti-money laundering or antiterrorism watch lists, or the like. The screen display may also include a drop down menu (not shown) for each listed customer, to allow the user to select a status for the customer such as “Blocked” (i.e., prevented from initiating and/or receiving remittances) or “Active” (i.e., not “Blocked”).

[0093] Returning now to FIG. **5A**, if the user pulls down the “Admin” menu **516**, the following menu options are available: “User Rights”, “Uploads”, and “Add Suspect Cus-

tomers. If the user selects the "User Rights" option, then a screen display like FIG. 26 is provided. FIG. 26, in an essentially conventional manner, allows a supervisory user to define access rights for various registered users of the system.

[0094] If the user selects the "Uploads" option from menu 516, then a screen display like FIG. 27 is provided. The screen display 27 may be manipulated by the user to select files for uploading.

[0095] If the user selects the "Add Suspect Customer" option from menu 516, then a screen display like FIG. 28 is provided. The user may employ the screen display of FIG. 28 to launch a search for certain customers by name, by address, etc., and then may use an additional screen display (not shown) to select one or more customers from the search results to a list of suspect customers.

[0096] Referring once more to FIG. 5A, if the user pulls down the "Reports & Queries" menu 518, the following menu options are available: "Queries" and "Reports". If the user selects the "Queries" option, then a query form (screen display) like FIG. 29 is provided to allow the user to query a transaction database as to one or more particular customers and/or one or more particular transactions. If the user selects the "Reports" option, then a screen display like FIG. 30 is provided, to allow the user to select a report for printing and/or export to an external spreadsheet program.

[0097] The discussion will now turn, from the FI administrative tools illustrated in FIGS. 5-30, to aspects of a customer user interface, as represented in FIGS. 31-41.

[0098] FIG. 31 shows a sign-in screen display that may be accessed by a customer (or prospective customer) of an FI in connection with the system of FIG. 2. As is also the case with the screen displays shown in FIGS. 32-41, the screen display of FIG. 31 may be downloaded from a computer 202 (FIG. 2) operated by or on behalf of the FI, and displayed on the display screen of a personal computer operated by the customer and in communication with the computer 202. In FIG. 31, a new prospective customer may actuate a "New User Registration" button 3102 to access a screen display like that shown in FIG. 32. The prospective customer may then use the data entry fields in the screen display of FIG. 32 to begin registering with the system by entering personal information. Once the personal information (including mobile telephone number) has been entered, and the customer has indicated that the data entry is complete, the system may then automatically place a telephone call to the customer's mobile telephone to confirm at least that the customer really is in possession of the telephone that has been assigned the mobile telephone number that the customer has entered. After this procedure has been successfully completed, the customer has been registered in the system as a customer-user and is then prompted to proceed with registering his/her payment card account that is to be used for funding remittance transactions. A data entry display screen that the customer may use to identify the funding account is shown in FIG. 33. It will be observed that the funding account may be a payment card account such as an account issued by the FI under the "MasterCard" brand.

[0099] Once the customer has entered the funding account information, he/she may next be prompted to proceed with storing information that identifies a recipient to whom the customer intends to send remittances via the system. A data entry display screen that may be used for this purpose is shown in FIG. 34. Part of the information required to complete this display screen includes the payment card account of

the recipient, so that remittances to the designated recipient may be routed as "payment transactions" in a payment card system.

[0100] Returning to FIG. 31, the customer (now assumed to be a previously registered customer) may use data entry fields 3104, 3106 to enter his/her user identification (e.g., his/her mobile telephone number) and PIN. Upon verification of the user ID and PIN, the screen display shown in FIG. 34A is presented. This screen display is a main menu page, and includes options 3402 ("Send"), 3406 ("Estimate") and 3408 ("My Account"), with the latter being a pull down menu.

[0101] If the customer pulls down the "My Account" menu 3408, the menu options that are displayed may be "Personal Details", "Mobile Phone", "PIN", "Funding Accounts", "Receiver Details" and "Transactions". Any these options may be selected by the customer for the purpose of updating information stored in the FI computer 202 relative to the customer's online user account. If the customer selects the "Personal Details" option, then a data entry form (which is not shown) is provided to allow the customer to enter a change of address or otherwise to update personal information.

[0102] If the user selects the "Mobile Phone" option, then a data entry form (which is not shown) is provided to allow the customer to enter his/her updated mobile telephone number. In some embodiments, the system automatically calls back the new mobile telephone number to confirm the customer's possession of the mobile telephone in question before the updating operation is allowed to be completed.

[0103] If the customer selects the "PIN" option, then a data entry form (which is not shown) is provided to allow the customer to change his PIN.

[0104] If the customer selects the "Funding Accounts" option, then a display screen as shown in FIG. 35 is provided. As will be appreciated from examining FIG. 35, this screen display allows the customer to add one or more new accounts (either payment card accounts or bank accounts) to a list of the customer's accounts that are available to fund remittance transactions. The screen display of FIG. 35 also allows the customer to delete one or more accounts from the list of funding accounts.

[0105] If the customer selects the "Receiver Details" options, then a display screen as shown in FIG. 36 is provided. As will be appreciated from examining FIG. 36, this screen display allows the customer to add an additional recipient's account to the list of accounts to which the customer may send remittances. The screen display of FIG. 36 also allows the customer to delete one or more accounts from the list of recipients' accounts.

[0106] If the customer selects the "Transactions" option, then a search inquiry screen display (not shown) is provided to allow the customer to submit a search query to locate information relating to one or more of the customer's previous remittance transactions. FIG. 37 is an example results page that may be provided in response to a search query of the type that was just described.

[0107] Referring again to FIG. 34A, if the customer wishes to make a remittance, he/she may select the "Send" option 3402, in which case a screen display as shown in FIG. 38 may be provided. The screen display of FIG. 38 includes a list 3802 of the customer's available funding accounts, and a list 3804 of recipients that the customer has previously entered into the system. The customer may select a radio button from the first list 3802 to select a funding account for the desired remittance. The customer may select the recipient for the

remittance by selecting a radio button from the second list **3804**. By entering a currency amount in the data entry field **3806**, the customer may set the amount of money to be transferred to the selected recipient. By clicking on the “Get Estimate” button **3808**, the customer can obtain an estimated summary of the cost and outcome of the desired remittance, as presented at **3902** in FIG. **39**. The sender currency may be selected automatically by the system based on the currency in which the funding account is denominated, and likewise the recipient currency may be selected automatically by the system based on the currency in which the selected recipient account is denominated. Based on these two currencies and the sender and recipient countries, the system may access the applicable service fee profile(s) for use in determining the service fee and the foreign exchange markup. The base currency exchange rate may be determined from a daily fix obtained from a source of exchange rate information.

[0108] Upon the customer actuating the “Proceed” button **3904** in FIG. **39**, the confirmation screen display shown in FIG. **40** is provided. The customer may then cause the desired remittance transaction to be executed by actuating the “Proceed” button **4002** in FIG. **40**. Upon the customer doing so, and assuming everything is in order, then the remittance transaction is processed, and the screen display of FIG. **41** is provided to confirm successful processing of the remittance transaction. (In some embodiments, after the customer actuates the “Proceed” button, the FI computer may initiate a telephone call to the customer’s mobile telephone, and require the customer to enter a supplementary PIN or the like, before executing the remittance transaction.)

[0109] Upon the customer’s actuation of the “Proceed” button **4002** in FIG. **40**, the customer FI (the sending FI) initiates a payment transaction in the payment card system to implement the remittance requested by the customer, with the payment transaction to be charged to the customer’s selected payment card account and to be routed to the selected recipient’s payment card account (alternatively a remittance to a non-payment card account may occur, as will be described below in connection with FIGS. **42-46**). Conventional processing of a payment transaction in the payment card system may take place, and in addition the recipient may be notified upon completion of the transaction when the transferred funds are available in the recipient’s account.

[0110] According to some aspects of the invention, the recipient’s account selected by the customer need not be a payment card account. Systems and processes will now be described, with reference to FIGS. **42-46**, in which a payment card system is employed for remittances to be received in non-payment-card accounts.

[0111] FIG. **42** is a block diagram that illustrates a remittance system **4200** in which an international payment card system **4202** (akin to payment system **102**, FIG. **1**) is used to make a remittance into a bank account (recipient’s account) **4204** that is not a payment card account. As the remittance system **4200** is illustrated in FIG. **42**, only the system components that may be involved in a single remittance transaction are shown. Nevertheless, in practice, there may be a large number of additional system components, as will be described in further detail below.

[0112] The remittance system **4200** may include a personal computer **206** that is operated by a customer of an FI to initiate a remittance transaction. In particular, the personal computer **206** may be used to access a remittance services website **4206** hosted by, e.g., the computer **202** (FIG. **2**)

operated by or on behalf of the FI which issued the customer’s payment card account from which the customer wishes to fund the remittance transaction. The personal computer **206** may access the remittance services website **4206** via a network **208** such as the Internet. The interaction of the customer (via the customer’s PC **206**) with the remittance services website **4206** may be via a user interface like that illustrated above in FIGS. **31**, **34A** and **38-41**. For present purposes, it will be assumed that the customer has selected as the recipient’s account for the remittance transaction a bank account that is located in a foreign country (foreign bank) and that is not a payment card account.

[0113] The remittance system **4200** may also include a server computer **4208** that handles remittance transaction requests forwarded from the remittance website **4206**/FI computer **202**. The remittance transaction requests initiated by FI customers may be sent from the FI computer to the remittance request handling server computer **4208** via a data communication network which may be the Internet **208** or which may be a separate (e.g., private) network, which is not separately shown. The remittance request handling server computer **4208** may be operated by or on behalf of the payment card association that operates the payment system network **4202**.

[0114] The remittance request handling server computer **4208** is in communication with the payment system network **4202**, via a payment system gateway computer **4210**, for the purpose of initiating payment card system payment transactions to be routed via the payment system network **4202**. Block **4212** in FIG. **42** represents both (a) an Agent Bank appointed by the payment card association in the country in which recipient’s bank account is located, and (b) a computer operated by or on behalf of the Agent Bank. A settlement account **4214** is maintained by the Agent Bank to receive funds via payment transactions in the payment system network **4202** and to disburse the funds by suitable transfer mechanisms to the recipients’ accounts. Thus the settlement account **4214** may serve in effect as the target payment card account for payment transactions routed by the payment system network **4202**. The Agent Bank also receives (e.g., on a daily basis) a file **4216** of funds transfer instructions from remittance request handling server computer **4208**.

[0115] In cases where the recipient’s account **4204** is maintained (as depicted in FIG. **42**) with a bank **4218** that is not the Agent Bank **4212**, the remittance is completed with an inter-bank electronic funds transfer (EFT) **4220** from the settlement account **4214** into the recipient’s account **4204**. In the special case when the recipient’s account is at the Agent Bank, the remittance is completed with an intrabank EFT **4222**, which is indicated in phantom.

[0116] To consider more broadly the remittance system **4200**, it should be understood that there may be many (potentially hundreds of thousands or millions) of user computers (beyond the one user computer **206** which is shown in FIG. **42**) that may potentially participate in the remittance system, and in fact a considerable number of user computers may simultaneously access the remittance system **4200** for the purpose of initiating remittance transactions. There may be only one remittance website **4206**, or alternatively, there may be a separate website for each country or region from which remittances may be sent through the system **4200** and/or a separate website for each sending FI. Similarly, there may be only one remittance request handling server computer **4208**, or there may be a number of such computers, each serving a

respective country or region and/or backing up another such computer. There may also be a number of payment system gateways **4210**. Preferably, but not necessarily, the payment system network **4202** may be a single worldwide payment system such as the Banknet system operated by MasterCard International Inc., the assignee hereof.

[0117] Continuing to consider the remittance system **4200** from a broad point of view, there may be a respective Agent Bank **4212** and a respective settlement account **4214** in each country to which remittances may be sent via the system **4200**. Moreover, there may be a considerable number of recipient banks **4218** in each country to which remittances may be sent via the system **4200**. For example, the recipient banks may include every bank that participates in an EFT or ACH (automated clearing house) system with the Agent Bank in a given country.

[0118] FIG. 43 is a block diagram that illustrates an example embodiment of the remittance request handling server computer **4208** shown in FIG. 42.

[0119] In its hardware aspects, the remittance request handling server computer **4208** may be conventional, and similar to the hardware components described in connection with the computers described above with reference to FIGS. 3 and 4. The hardware aspects of the remittance request handling server computer **4208** will therefore not be further described, except to mention that the remittance request handling server computer **4208** may include a processor **4300** in communication with a communication device **4301**, a storage device **4304**, an input device **4306**, and an output device **4308**.

[0120] The storage device **4304** may store one or more application programs, represented by blocks **4310**, **4312** and **4314**, and that include software program instructions to control the processor **4300**. For example, program **4310** may program the processor **4300** to handle incoming requests for remittance transactions received via the remittance website **4206** (FIG. 42). Program **4312** may program the processor **4300** to respond to remittance transaction requests by initiating payment transactions to be routed via the payment system network **4202** to the respective Agent Bank **4212** and settlement account **4214** in the country to which the remittance is to be sent. Program **4314** may program the processor **4300** to prepare and transmit files of instructions to the Agent Banks in the various countries to perform funds transfers to the recipients' accounts **4204**. Further, one or more databases **4316** stored on the storage device **4304** may contain data relating to remittance transactions, instructions issued, etc. (Although the programs **4310**, **4312** and **4314** are presented as separate applications, in practice any two or more of them may be combined into a single application.)

[0121] In addition to the software programs expressly listed above, the remittance request handling server computer **4208** may be programmed with other software, such as one or more operating systems, device drivers, database management programs, etc.

[0122] FIG. 44 is a block diagram that illustrates an example embodiment of the Agent Bank computer **4212**.

[0123] In its hardware aspects, the Agent Bank computer **4212** may be conventional, and similar to the hardware components described in connection with the computers described above with reference to FIGS. 3, 4 and 43. The hardware aspects of the Agent

[0124] Bank computer **4212** will therefore not be further described, except to mention that the Agent Bank computer **4212** may include a processor **4400** in communication with a

communication device **4401**, a storage device **4404**, an input device **4406**, and an output device **4408**.

[0125] The storage device **4404** may store one or more application programs, represented by blocks **4410**, **4412** and **4414**, and that include software program instructions to control the processor **4400**. For example, program **4410** may program the processor **4400** to manage the settlement account **4214** (FIG. 42), including responding to and receiving payment transactions routed to the settlement account **4214** via the payment system network **4202**, and disbursement of funds from the settlement account **4214**. Program **4412** may program the processor **4400** to receive and interpret funds transfer instruction files received from the remittance request handling server computer **4208**. Program **4414** may program the processor **4400** to interact with an EFT network (not separately shown) to implement electronic funds transfer from the settlement account **4214** to the recipients' accounts (e.g., account **4204** shown in FIG. 42). Further, one or more databases **4416** stored on the storage device **4304** may contain data relating to transfers of funds into and out of the settlement account **4214**. (Although the programs **4410**, **4412** and **4414** are presented as separate applications, in practice any two or more of them may be combined into a single application.)

[0126] In addition to the software programs expressly listed above, the Agent Bank computer **4212** may be programmed with other software, such as one or more operating systems, device drivers, database management programs, etc.

[0127] FIG. 45 is a flow chart that illustrates a process that may be performed by the remittance request handling server computer **4208**

[0128] At **4502** in FIG. 45, the remittance request handling server computer **4208** determines whether a remittance request received via the remittance website **4206** is to be directed to a recipient's account which is not a payment card account. If so, then step **4504** follows **4502**. (In the case where the recipient's account indicated in the remittance request is a payment card account, then the remittance request handling server computer **4208** may initiate a conventional payment card system payment transaction to be routed to the recipient's payment card account, as described in the above-mentioned, commonly assigned U.S. patent application Ser. No. 11/836,984.)

[0129] At step **4504**, the remittance request handling server computer **4208** initiates a payment transaction to be routed via the payment system network **4202** to the settlement account **4214** in the country in which the recipient's account **4204** is located. The payment transaction may be funded from the sender's payment card account designated in the remittance request. Any currency translation required in connection with the payment transaction may be performed in a conventional manner by the remittance request handling server computer **4208**. At substantially the same time, and as indicated at **4506**, the remittance request handling server computer **4208** stores an instruction to be sent later to the Agent Bank computer **4212** to instruct the Agent Bank computer **4212** to transfer the proceeds of the payment transaction initiated at **4504** from the settlement account **4214** to the recipient's account **4204**. Thereafter, and as indicated at **4508**, the instruction stored at **4506** is sent to the Agent Bank computer **4212** as part of a file **4224** (FIG. 42) of funds transfer instructions. For example, this may be done as part of an end-of-day batch process performed by the remittance request handling server computer **4208**. In practice, the remit-

tance request handling server computer **4208** may send such a funds transfer instruction file daily to the respective Agent Bank computer **4212** for each country to which the remittance request handling server computer **4208** sends remittances by the process illustrated in FIG. **42**.

[0130] FIG. **46** is a flow chart that illustrates a process that may be performed by the Agent Bank computer **4212**.

[0131] At **4602**, the Agent Bank computer **4212** receives in the settlement account **4214** payment transactions routed to the settlement account **4214** by the remittance request handling server computer **4208** via the payment system network **4202**. This may take place on an ongoing basis and may include sending of acknowledgement messages or the like in connection with the payment transactions, as would conventionally be performed by the issuer of the recipient's payment card account in the case of a conventional payment transaction.

[0132] At **4604**, the Agent Bank computer **4212** receives from the remittance request handling server computer **4208** an instruction file **4224** (FIG. **42**) that instructs the Agent Bank computer **4212** to execute funds transfers to disburse the funds received in the settlement account **4212** via the payment transactions received therein in step **4602**. Then for each instruction (as indicated at **4606**) in the instruction file **4224**, the Agent Bank computer **4212** determines, at **4608**, whether the recipient's bank account designated in the current instruction is at a bank different from the Agent Bank or is at the Agent Bank. If the recipient's bank account is at a different bank (bank **4218**, FIG. **42**), then as indicated at **4610**, the Agent Bank computer **4212** executes an interbank EFT to transfer the proceeds of the remittance to the recipient's account **4204**. (Alternatively, in at least some cases, the transfer to the recipient's bank **4218** may be via an ACH transaction.)

[0133] However, if the Agent Bank computer **4212** determines at **4608** that the recipient's bank account designated in the current instruction is at the Agent Bank, then as indicated at **4612**, the Agent Bank computer **4212** executes an intrabank EFT to transfer the proceeds of the remittance to the recipient's account at the Agent Bank.

[0134] With the remittance process just described with reference to FIGS. **42-46**, a recipient who does not have a payment card account may nonetheless receive remittances that utilize the highly efficient funds transfer capabilities of an international payment card system like that operated by the assignee hereof.

[0135] In some embodiments of the "direct-to-bank" remittance system depicted in FIG. **42**, there may be, as noted above, a number of remittance request handling server computers **4208**—one for each country or region in the system, for example. Although FIG. **42** suggests that each remittance request handling server computer **4208** separately sends an EFT instruction file **4224** to the respective Agent Bank computer **4212** in each other country, in practice at least some of the separate EFT instruction files **4224** directed to a given Agent Bank computer **4212** may be aggregated at a central processing facility (not shown) so that each Agent Bank computer **4212** may receive only one EFT instruction file **4224** rather than a separate EFT instruction file **4224** originating from each remittance request handling server computer **4208**.

[0136] In the above discussion of FIGS. **42** and **45** it has been assumed that the source of funds for the "direct-to-bank" transfer was the sender's payment card account. Alternatively, however, the source of funds may be a bank account

belonging to the sender that is not a payment card account. To accommodate this alternative, the remittance request handling server computer **4208** may be directly interfaced to an internet banking system (not shown) that is operated by the sender's bank.

[0137] FIG. **47** is a flow chart that illustrates a process that may be performed by a financial institution computer **104** or **202** in the system of FIGS. **1** and/or **2**.

[0138] At **4702** in FIG. **47**, a list of individuals, including their names and possibly also their residence addresses, is downloaded to the financial institution computer **104** or **202**. The list may have been developed by a law enforcement agency as a compilation of names of individuals who are believed to be actually or potentially involved in transfers of funds for illicit purposes, and thus who should be prevented from using banking facilities for such purposes. This list will hereinafter be referred to as a "suspect persons list".

[0139] At **4704**, the financial institution computer **104** or **202** determines whether it has received data to update the suspect persons list. If so, the financial institution computer **104** or **202** updates the suspect persons list, as indicated at **4706**. Following **4706**, or directly following **4704** if no update is received, is decision block **4708**. At **4708** it is determined whether the financial institution computer **104** or **202** has received a request to perform a remittance transaction. If not, then the process of FIG. **47** loops back to **4704**.

[0140] It will be appreciated that if a request for a remittance transaction is determined at **4708** to have been received, then the request would originate from a sender who is a customer of the financial institution that operates the computer **104** or **202**, and the request would also specify a recipient, presumably one who has previously been entered in the sender's remittance website user account (e.g., as per FIG. **36**, as discussed above).

[0141] If a positive determination (i.e. remittance request received) is made at **4708**, then decision block **4710** follows **4708**. At **4710**, the financial institution computer **104** or **202** accesses the suspect persons list (as currently updated) to determine whether either one of the sender or the recipient is currently listed on the suspect persons list. If not, then the financial institution computer **104** or **202** proceeds to execute the requested remittance transaction, as indicated at **4712** (assuming that the sender's account is in a condition to support the transaction and assuming that all else is in order). However, if either the sender or recipient is on the suspect persons list, then the financial institution computer **104** or **202** declines to perform the requested remittance transaction, as indicated at **4714**. Following either **4712** or **4714**, the process of FIG. **47** loops back to **4704**.

[0142] As a result of the process of FIG. **47**, for each requested remittance transaction, the financial institution computer **104** or **202** checks the suspect persons list for the presence of the sender's and the recipient's name on the list in real time after receiving the request for the transaction and before executing the remittance transaction. More specifically, the financial institution computer **104** or **202** may compare the sender and the recipient with the suspect persons list in real time with respect to each request for a remittance transaction (also referred to as "funds transfer requests"). In this way, the financial institution computer **104** or **202** may perform very effectively in excluding suspect persons from utilizing the remittance system. It will be appreciated that the financial institution computer **104** or **202** may loop through

the process of FIG. 47 many times, executing step 4710 with respect to each one of numerous remittance requests.

[0143] In at least some of the screen displays presented in the appended drawings, there are button portions or regions, also referred to as “buttons”. It should be understood that, in accordance with conventional practices, such buttons may be actuated by suitably operating a pointing device such as a mouse by positioning a cursor (not shown) on the button while clicking a button on the pointing device. Such an operation is sometimes referred to as “clicking” on the button region of the screen display. The pointing device may be one of the computer input devices shown in the various computer block diagrams included in the drawings, or may be a component of a user computer shown in the drawings. It will also be appreciated that entry of data may be accomplished by using a computer keyboard (also one of the computer input devices) after using a pointing device to position a cursor in the desired data entry fields among the data entry fields shown in the appended screen display drawings.

[0144] As used herein and in the appended claims, “displaying” a screen display includes downloading a webpage from a server computer for display on a client computer.

[0145] It is noted that “payment transaction” is a term of art in the field of payment card systems, and refers to a transaction in which—in contradistinction to a purchase transaction—funds flow from an acquirer to an issuer as a credit to a payment card account issued to the issuer. In this context, the sending FI may be considered to be an acquirer and the receiving FI may be considered to be an issuer.

[0146] As used herein and in the appended claims, a “service fee” includes a flat fee and/or a percentage-based fee and/or a combination thereof and/or a foreign exchange markup.

[0147] The flow charts and descriptions thereof herein should not be understood to prescribe a fixed order of performing the method steps described therein. Rather the method steps may be performed in any order that is practicable.

[0148] As used herein and in the appended claims, the term “payment card account” includes a credit card account or a deposit account that the account holder may access using a debit card. The term “payment card account number” includes a number that identifies a payment card account or a number carried by a payment card, or a number that is used to route a transaction in a payment system that handles debit card and/or credit card transactions. The term “payment card” includes a credit card or a debit card.

[0149] Although the present invention has been described in connection with specific exemplary embodiments, it should be understood that various changes, substitutions, and alterations apparent to those skilled in the art can be made to the disclosed embodiments without departing from the spirit and scope of the invention as set forth in the appended claims.

What is claimed is:

1. A method comprising:

receiving, by a processor, a funds transfer request specifying a transaction amount, a destination bank account and a source account;

determining, by the processor, that the destination account is not a payment card account;

initiating, by the processor based on the funds transfer request, a payment transaction routed from the source account via a payment card system network to a payment card system settlement account, the payment card sys-

tem settlement account established in an agent bank in the same country as the destination bank account;

storing, by the processor in a storage device, an instruction file comprising transfer instructions for the agent bank to transfer the transaction amount from the payment card system settlement account to the destination bank account; and

transmitting, by the processor, the instruction file to the agent bank.

2. The method of claim 1, wherein the destination bank account is at a bank that is different from the agent bank.

3. The method of claim 1, wherein the funds transfer request is received via the Internet.

4. The method of claim 3, wherein the funds transfer request is received via a website operated by or on behalf of a bank that issued the source account.

5. The method of claim 1, wherein:

the source account is located in a first country; and

the settlement account and the destination bank account are located in a second country that is different from the first country.

6. The method of claim 1, wherein the source account is a payment card account.

7. The method of claim 1, wherein the instruction file is transmitted by the processor as part of a batch process to an agent bank computer in the same country as the destination bank account.

8. An apparatus comprising:

a processor;

a communications device operably connected to the processor; and

a non-transitory storage device operably connected to the processor, the non-transitory storage device storing instructions configured to cause the processor to:

receive a funds transfer request specifying a transaction amount, a destination bank account and a source account;

determine that the destination account is not a payment card account;

initiate a payment transaction routed from the source account via a payment card system network to a payment card system settlement account, the payment card system settlement account established in an agent bank in the same country as the destination bank account;

store an instruction file in the storage device, the instruction file comprising transfer instructions for the agent bank to transfer the transaction amount from the payment card system settlement account to the destination bank account; and

transmit the instruction file to the agent bank.

9. A non-transitory computer readable medium storing instructions configured to cause a processor to:

receive a funds transfer request specifying a transaction amount, a destination bank account and a source account;

determine that the destination account is not a payment card account;

initiate a payment transaction routed from the source account via a payment card system network to a payment card system settlement account, the payment card system settlement account established in an agent bank in the same country as the destination bank account;

store an instruction file in the storage device, the instruction file comprising transfer instructions for the agent bank to transfer the transaction amount from the payment card system settlement account to the destination bank account; and

transmit the instruction file to the agent bank.

10. The non-transitory computer readable medium of claim **9**, wherein the instructions for determining that the destination account is not a payment card account further comprises instructions configured to determine that the destination bank account is at a bank that is different from the agent bank.

11. The non-transitory computer readable medium of claim **9**, wherein the instructions for receiving the funds transfer request further comprise instructions configured to receive the funds transfer request via the Internet.

12. The non-transitory computer readable medium of claim **11**, wherein the instructions for receiving the funds transfer request via the Internet further comprises instructions configured to receive the funds transfer request via a website operated by or on behalf of a bank that issued the source account.

13. The non-transitory computer readable medium of claim **9**, wherein the instructions for initiating a payment transaction further comprises instructions configured to determine that the source account is located in a first country and that the settlement account and the destination bank account are located in a second country that is different from the first country.

14. The non-transitory computer readable medium of claim **9**, wherein the instructions for determining that the destination account is not a payment card account further comprises instructions configured to determine that the source account is a payment card account.

15. The non-transitory computer readable medium of claim **9**, wherein the instructions for transmitting the instruction file to the agent bank further comprises instructions configured to transmit the instruction file as part of a batch process to an agent bank computer in the same country as the destination bank account.

* * * * *