

Jan. 7, 1958

J. TOURAINE

2,819,081

EXERCISERS

Filed Oct. 3, 1955

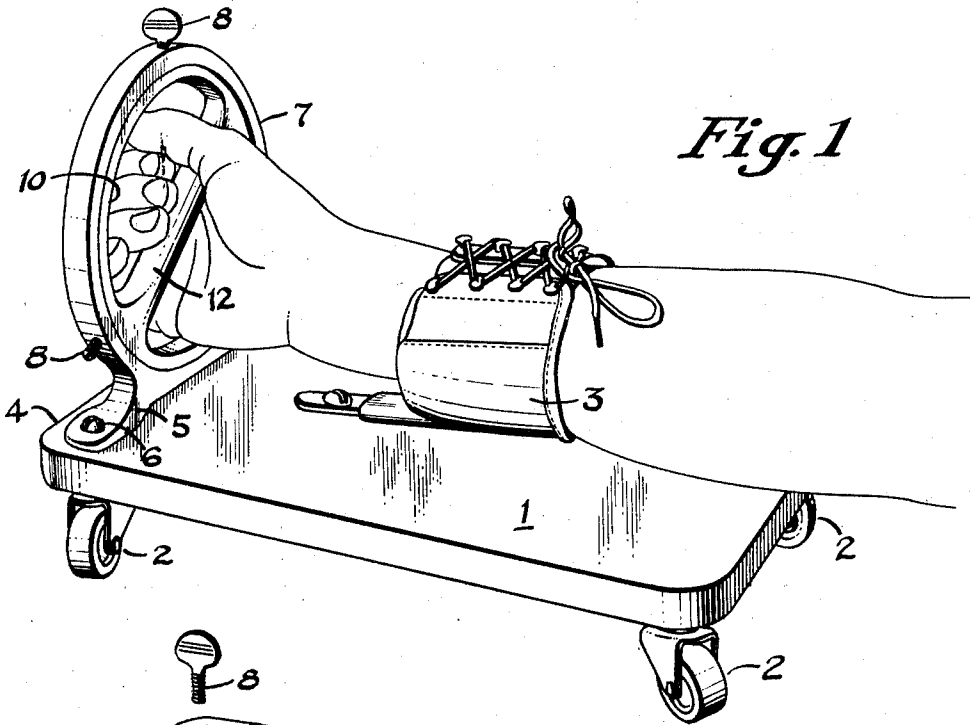

Fig. 1

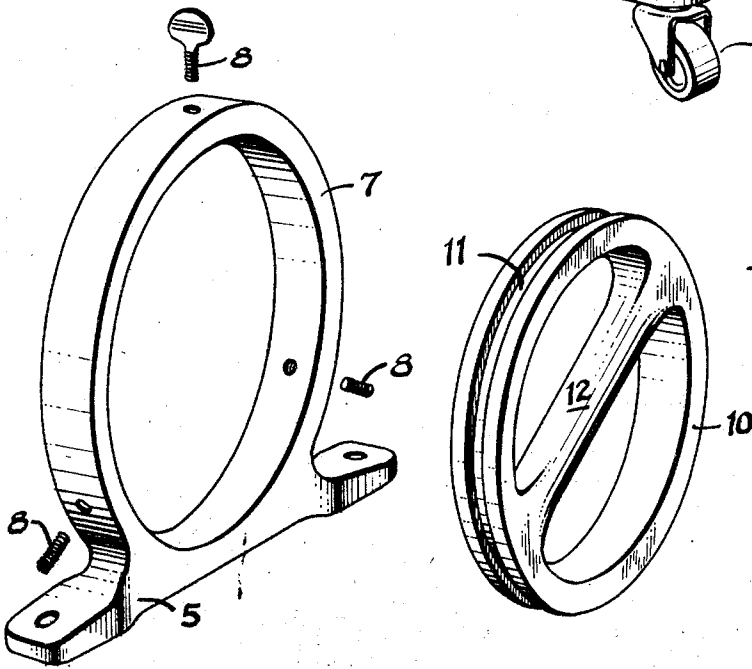

Fig. 3

Fig. 2

INVENTOR

JOHN TOURAINE

BY *Edwin H. Brandt*
Agent

1

2,819,081

EXERCISERS

John Touraine, Miami Beach, Fla.

Application October 3, 1955, Serial No. 537,924

4 Claims. (Cl. 272-67)

The present invention relates generally to exercisers, and more particularly to exercisers for the upper extremity of the human body.

Briefly describing my invention, it includes (1) a wooden platform, which is of sufficiently small size that it is readily portable, (2) a hand-hold, secured to the platform, which may be rotated through 360° in either direction, and which may be freely rotated, or locked in position at any desired angle, (3) a cuff secured to the platform and securable also about the arm or wrist of the user, (4) wheels or casters on the under side of the platform. The hand-hold consists of an outer metal ring and an inner metal ring, the latter arranged for rotation relative to the former, and the inner ring provided with an annular groove, and with set screws for locking the rings with respect to each other. A hand bar, which may be comfortably grasped by the user, extends diametrically of the inner ring.

It is, accordingly, a broad object of my invention to provide a novel exerciser for the upper extremity.

It is another object of the invention to provide a novel exerciser of the hand grip type.

Another object of the invention resides in the provision of a novel hand grip exerciser which is particularly economical of fabrication, and simple of construction.

A further object of the present invention resides in the provision of a hand grip exerciser in which the hand grip element may be oriented 360° in either direction, and adjusted to be rotatable or locked, when in use.

The above and still further features, objects, and advantages of the invention will become apparent upon consideration of the following detailed description of a specific embodiment of the invention, especially when taken in conjunction with the accompanying drawings, wherein:

Figure 1 is a view in perspective of an exerciser in accordance with the invention,

Figure 2 is a view in perspective of one ring component of the exerciser of Figure 1; and

Figure 3 is a view in perspective of another ring component of the exerciser of Figure 1.

My novel exerciser provides exercise which helps to normalize various abnormal conditions of the upper extremities, including the joints, and provides actions which include movements of the joints of the shoulder, elbow, wrist, and fingers, in various positions. The exerciser may be employed as a therapeutic device to aid in the recovery of persons suffering afflictions or illness causing limitations of function of the upper part of the body, or any part thereof, and also which assists in maintaining normal conditions when these exist. The exerciser is sufficiently simple in application to the body and in use that persons of all ages, from the youngest to the oldest, may benefit from its use.

The provision of a forearm cuff renders the exerciser usable by those without voluntary control of arm musculature, and once the arm has been secured no supervision is required. The exerciser may be oriented in any

2

desired plane, horizontal, vertical, or intermediate, as desired.

I have found the exerciser incorporating my invention to be invaluable in loosening stiff joints, relaxing contracted muscles, and stretching of tight or contracted muscles. The exerciser may be employed for passive or active motion, and to resistive motion by adding weight or by changing the plane of operation from the horizontal, and the resistive force may be adjusted, and allowance made for pronation and supination of the hand. It has been found that my exerciser will also improve the postural position of the neck and back, since the neck and back muscles are involved in use of the exerciser.

In conclusion, then, my novel exerciser may be used for preventing further fixing of joint nobility, and increasing nobility of fixed joints increasing muscle strength and control, relaxing muscles, and the like.

Proceeding now, by reference to the accompanying drawings, to describe one specific embodiment of my invention, the reference numeral 1 denotes a platform, preferably fabricated of wood, or the like, and preferably measuring about 9" x 12". To the underside of the platform 1 is secured a plurality of casters or wheels 2. To the upper side of the platform 1, and approximately centrally thereof, is secured a cuff 3 within which the forearm of the user may be locked. Adjacent one end 4 of the platform 1 is secured by means of a bracket 5 and wood screws 6, a first ring 7 which may be fabricated of metal pipe and which includes three set screws or ring bolts 8, separated by 120° intervals, and extending radially through the ring 7.

A second metallic ring 10 fits snugly within the ring 7, and includes an annular groove 11 in its outer circumference. A diametrically extending hand grip 12 is provided for the inner ring 10.

The annular groove 11 of the inner ring 10 is secured by the set screws 8, which may be adjusted to lock the inner ring 10, or to provide frictional forces tending to prevent motion of inner ring 10.

In operation, the forearm of the user is secured within the cuff 3. The user then grips the hand grip 12, and assuming a suitable adjustment of set screws 8, performs such exercises as are suitable for or recommended for his particular condition.

While I have described and illustrated one specific example of the present invention it will be clear that variations of the specific details of construction may be resorted to without departing from the true spirit of the invention as defined in the appended claims.

What I claim is:

1. An exerciser comprising a platform, an upwardly directed outer ring secured to said platform, an inner ring having an annular groove extending about its outer circumference and having a diametrical hand-grip secured thereto, and single means for retaining said inner ring concentric with and rotatable within said outer ring and for permitting at will variation of the forces required to rotate said inner ring with respect to said outer ring, said single means comprising a plurality of set screws disposed about the circumference of said outer ring and extending therethrough into the annular groove in said inner ring and into at will variable frictional engagement with the bottom wall of said groove.

2. In combination, an outer ring, a platform having a plurality of wheels secured to one side and said outer ring secured to the other side thereof, an inner ring coaxial with said outer ring, manually adjustable means secured to one of said rings for adjustably frictionally engaging the other of said rings, said last means arranged to enable 360° rotation of said inner ring in either direction with respect to said outer ring, a hand grip extending

3

across the interior of said inner ring and a cuff secured to said one side of said platform, an axis of said cuff being substantially parallel with the axis of said rings, said cuff being axially displaced from said rings.

3. In combination, a platform, an outer ring secured to one side of said platform, an inner ring coaxial with and rotatable within said outer ring, means secured to one of said rings for frictionally engaging the other of said rings and for retaining said ring coaxial with the other of said rings, a hand grip extending across the inner ring and an arm engaging cuff secured to said one side of said platform, said cuff being axially displaced from said rings and axially aligned therewith.

4. The combination in accordance with claim 3, where-

4

in said means comprises a plurality of screws threaded into said outer ring and adjustably frictionally engaging said inner ring.

References Cited in the file of this patent

UNITED STATES PATENTS

641,519	Kerns -----	Jan. 16, 1900
1,333,005	Warner -----	Mar. 9, 1920
1,604,333	Anderson -----	Oct. 26, 1926
1,879,401	Monaco -----	Sept. 27, 1932
2,530,921	Tougas -----	Nov. 21, 1950
2,543,729	Magida -----	Feb. 27, 1951
2,621,043	Omstead -----	Dec. 9, 1952