

(No Model.)

3 Sheets—Sheet 1.

E. R. LEONARD.
FIREPROOF FLOOR AND CEILING.

No. 582,428.

Patented May 11, 1897.

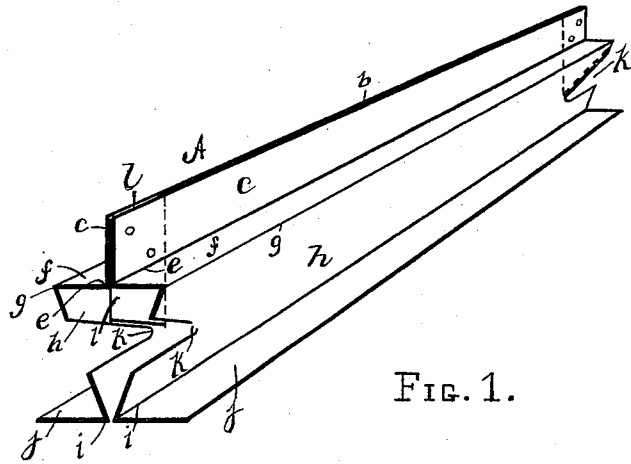

FIG. 1.

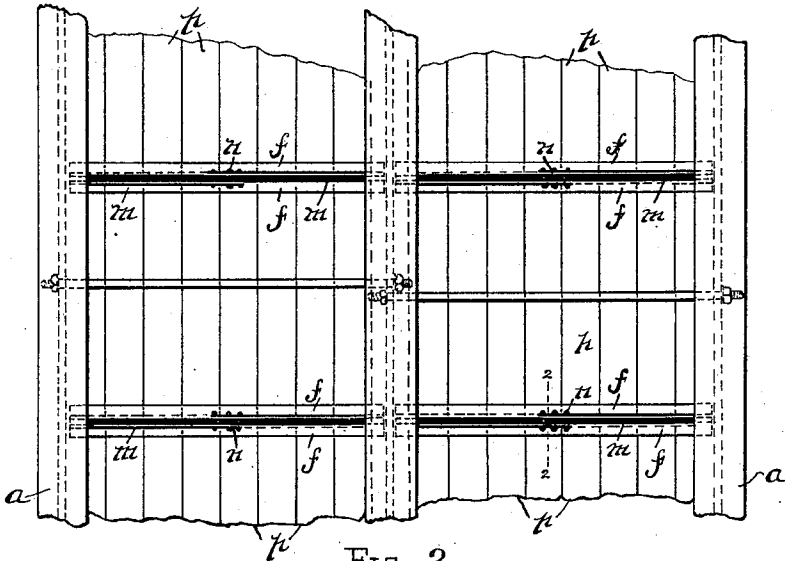

FIG. 2.

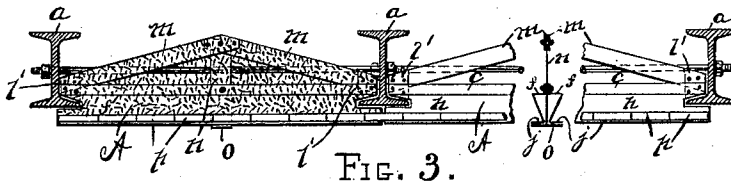

FIG. 3.

WITNESSES:

W. J. Morgan
Joseph Schorr

INVENTOR

E. R. Leonard

BY

A. P. Thayer

ATTORNEY

E. R. LEONARD.
FIREPROOF FLOOR AND CEILING.

No. 582,428.

Patented May 11, 1897.

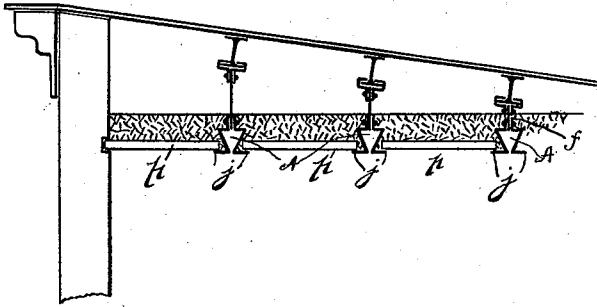

FIG. 4.

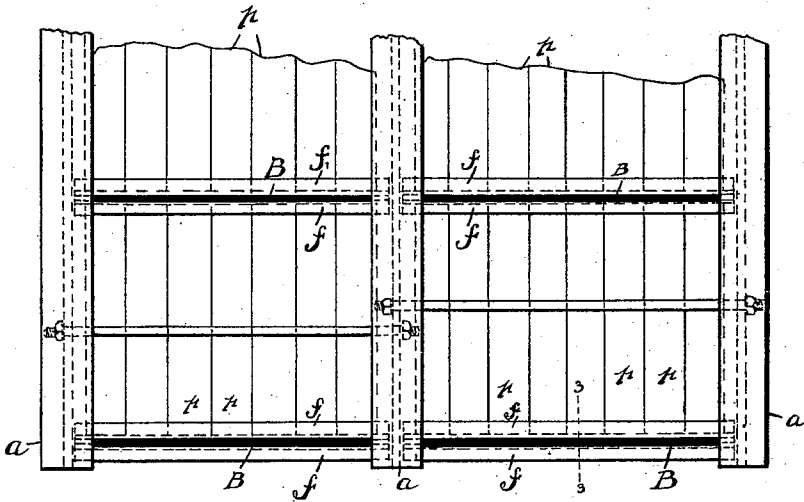

FIG. 5.

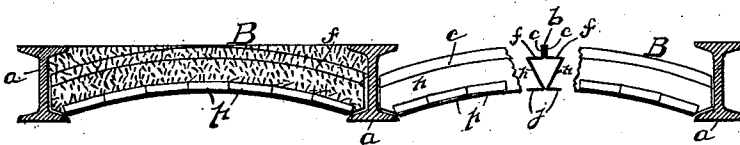

FIG. 6.

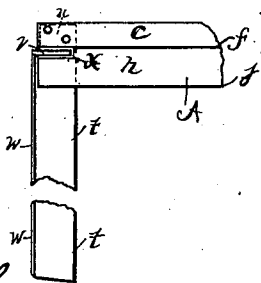

FIG. 13.

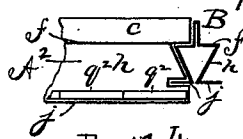

FIG. 14.

WITNESSES:

D. J. Morgan
Joseph Schorr

INVENTOR

Elof R. Leonard
BY
A. P. Thayer
ATTORNEY

(No Model.)

3 Sheets—Sheet 3.

E. R. LEONARD. FIREPROOF FLOOR AND CEILING.

No. 582,428.

Patented May 11, 1897.

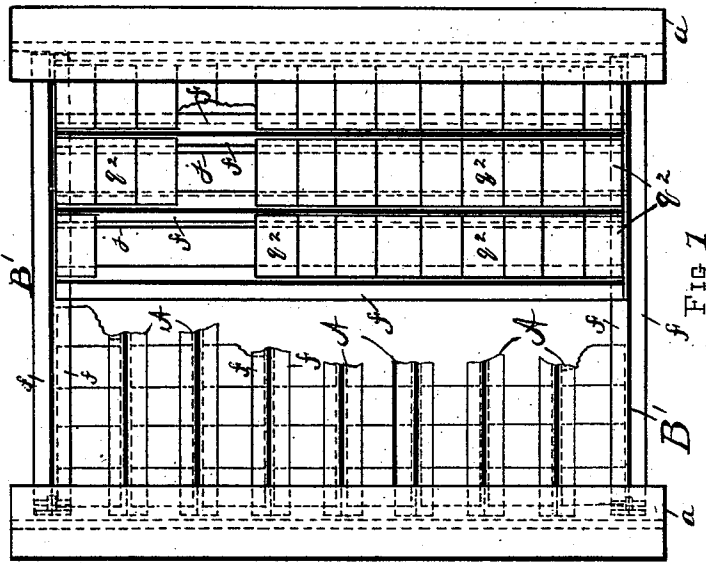

FIG. 7

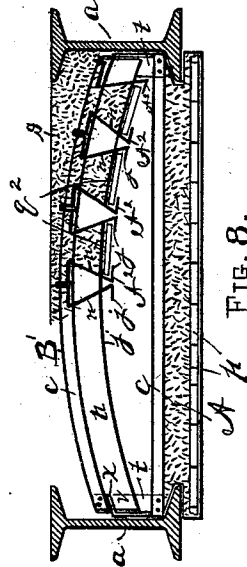

FIG. 8.

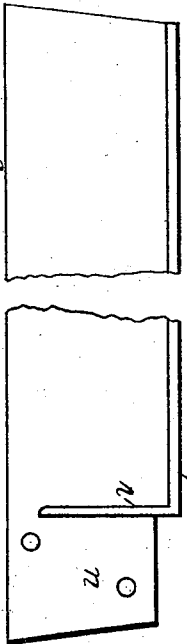

FIG. 11.

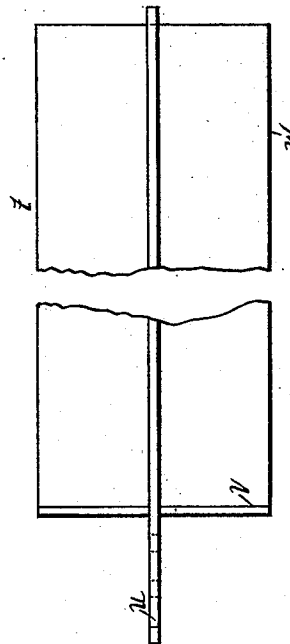

FIG. 10.

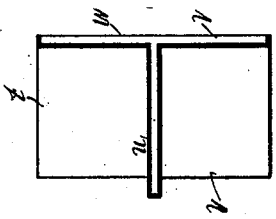

FIG. 12.

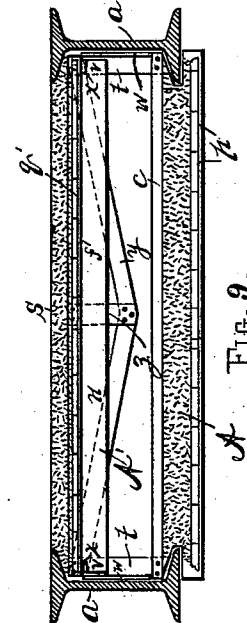

FIG. 9.

WITNESSES:

Ch. J. Longau
Joseph Schorr

INVENTOR

E. R. Leonard

BY

A. P. Meyer

ATTORNEY

UNITED STATES PATENT OFFICE.

ELOF R. LEONARD, OF NEW YORK, N. Y.

FIREPROOF FLOOR AND CEILING.

SPECIFICATION forming part of Letters Patent No. 582,428, dated May 11, 1897.

Application filed June 13, 1896. Serial No. 595,444. (No model.)

To all whom it may concern:

Be it known that I, ELOF R. LEONARD, a citizen of the United States, and a resident of New York city, in the county and State of New York, have invented certain new and useful Improvements in Fireproof Floors and Ceilings, of which the following is a specification.

My invention consists of improvements in fireproof beam-fillings and ceilings, whereby it is designed to provide stronger floors and ceilings of lighter weight and simpler construction, as hereinafter described, reference being made to the accompanying drawings, in which—

Figure 1 is a perspective view of a bar of improved construction which I have devised for supporting beam-fillings and ceilings. Fig. 2 is a plan view of floor-beams with beam-filling and ceiling supporting bars and ceiling-slabs in position. Fig. 3 is an end view of the structure of Fig. 2, with a part broken out and shown in section on line 2 2, Fig. 1, and a part having the cement filling included. Fig. 4 is a section showing the arrangement of my improved supporting-bars carrying a ceiling under a slanting roof. Fig. 5 is a plan of floor-beams with beam-filling and ceiling supporting bars and ceiling-slabs in position, as when arched beam-filling-supporting bars are used. Fig. 6 is an end view of the structure of Fig. 5, with a part broken out and shown in section on line 3 3, Fig. 4, and with a part showing the cement filling. Fig. 7 is a plan view of floor-beams, beam-filling and ceiling supporting bars, and ceiling and beam-filling supporting slabs in position when the beam-filling and ceiling are supported separately by independent systems of bars, the beam-filling-supporting bars being arched. Fig. 8 is an end elevation of the structure of Fig. 7 partly covered with beam-filling. Fig. 9 is an end elevation of part of a floor structure in which separate systems of bars are employed for the ceiling and beam-filling, the bars for the latter being straight. Fig. 10 is a front view, Fig. 11 a side view, and Fig. 12 an end view, of standards for the beam-filling-supporting bars when a system of beam-filling-supporting bars is used above the ceil-

ing-supporting bars. Fig. 13 is a side view of standard and part of a cross-bar, showing the arrangement when a separate upper system of cross-bars is used for the floor-support. Fig. 14 is a transverse section of a cross-bar and a side view of an intermediate in the arrangement of Fig. 8.

In the drawings, *a* represents metallic floor-beams of the common form now generally used for supporting the floors and ceilings. As at present constructed the fireproof filling between these beams is so heavy as to materially lessen the reserve supporting power for goods, and the ceilings are constructed in a way to be unnecessarily heavy with plaster or cement filling, which it is the purpose of my invention to improve by making them lighter and to simplify and cheapen the same.

In the first place I employ strong and light cross-bars for traversing the spaces between the floor-beams and resting on them, said bars consisting of sheet metal folded and bent substantially as shown in the drawings, whereof Fig. 1 is an enlarged view of a straight bar, in which the essential features of its construction are more clearly shown. In Figs. 2 and 3 additional elements for greater strength are represented, and in Figs. 5 and 8 the said improved bar is represented in arched form, as it may be shaped in some cases for the additional supporting power due to such form. In the construction of said improved cross-bar a thin sheet of metal of suitable length and width is taken and bent double at the middle *b* to form vertical webs *c* side by side in close contact with each other. It is also bent at *e e* to form horizontal converse shoulder-webs *f*. It is also bent again at *g g* to form downwardly-converging webs *h*, and it is also bent again at *i i* to form lateral base-flanges *j*.

In some cases notches *k* are made in the ends of the bars for engaging them with the lower flanges of the floor-beams, so that the lower parts of the cross-bars will reach lower than the floor-beams for carrying fireproof ceiling under the beams for their protection, as represented in Figs. 3, 8, and 9, and when so notched reinforcing-plates *l* will be inserted between the end portions of vertical webs

and riveted therein, said plates being shaped to rest at their lower ends on the lower flanges of the floor-beams for greater power of the ends of the bars for supporting weight.

5 The straight cross-bar is represented generally by reference-letter A. The arched cross-bar resting on the lower flanges of the floor-beams, as in Figs. 5 and 6, is designated by reference-letter B, and B' designates the
10 arched bars supported above the said lower flanges, as in Figs. 7 and 8.

The bars A will in some cases be further reinforced by a truss *m* and hanger *n* to strengthen them intermediately of the ends, 15 the end reinforcing-plates *l* being suitably extended upward for riveting the foot ends of the truss-bars *m* to their upper ends, as at *l'*, Fig. 2. Besides being riveted to the parts *c* of the bars A the hangers may have the
20 heads *o* below the flanges *j* for additional support.

Ceiling-slabs *p*, of slate or other suitable material, are to be placed on the flanges *j* of the cross-bars and covered on the under side 25 with a thin coat of plaster, of which a thickness sufficient to conceal the joints and the flanges *j* only is necessary, which, together with the thin slabs of slate or tiles that can be used, make a light fireproof ceiling.

30 When the floor is of moderate depth for supporting only light weight, the cement, concrete, or other filling material may be placed directly on the ceiling-slabs, as in Figs. 3 and 6, but in floors having deeper floor-beams *a*
35 for supporting great weight and in which there is more space than is needed for the required depth of filling-cements I provide other cross-bars, as A' or B', Figs. 9 and 8,

40 which I support above the ceiling-supporting bars A by standards *t*, on which the said filling S is carried by tiles or slabs *q'*, placed on the shoulders *f*, as in Fig. 9, when straight bars are used; but when arched bars, as B',
45 are used it is preferable, owing to the greater expense of making such bars, to use less of them by placing them farther apart than the slabs can reach with safety and using bars A²

50 of like form as bars A, but placed intermediate of and extending from one to another of bars B' and resting at the ends on them with the tiles or slabs *q'* supported on their flanges *j*, as in Fig. 8. In this case the notches in the ends of the bars will be shaped in conformity with the shape of parts *c*, *f*, and *h* of
55 bars B' and so that parts of bars A² will rest on shoulders *f* of bars B' and parts *h* of said bars A² will rest on flanges *j*. (See Fig. 14.)

The standards *t* for supporting these upper cross-bars are represented in detail and on an enlarged scale in Figs. 10, 11, and 12. They consist of T-bars, which have the lower ends of the middle webs suitably shaped for and being inserted in the slotted ends of the cross-bars A and resting on the flanges of the floor-beams to reinforce said cross-bars same as
65 plates *l*, and the upper ends have extensions

u of the middle web inserted in like slots of the bars A', together with flanges *v*, formed of the head-plate *w* of the T and projecting lengthwise of the cross-beams into slots *x* of 70 said bars under the shoulders *f* for substantial support of the cross-bars when riveted through the webs *c* of the cross-bars and riveted parts *u* of the standards, said standards being arranged with the head-plates *w* of the T 75 against the webs of the floor-beams.

When required, the cross-bars A' may be reinforced for support intermediate of their ends by the inverted trusses *y z*.

In Fig. 4 I represent the cross-bars A suspended from a slanting roof, as they may be 80 used for supporting the ceiling-slabs *p* of the ceiling directly under the roof where floor-beams are not used, with concrete above the slabs. 85

I claim as my invention—

1. The combination of the sheet-metal supporting-bar, the truss supporting the middle portion of the bar, said truss having its ends connected with the ends of the bar by the reinforcing-plates of said ends of the bar substantially as described. 90

2. The combination with the floor-beams, of the sheet-metal cross-bars having the divergent flanges *j*, and the ceiling-slabs *p* supported on said flanges below the edges of the floor-beams, said cross-bars being notched in the ends to engage the flanges of the floor-beams and having the reinforcing-plates substantially as described. 95 100

3. The combination with the floor-beams, of sheet-metal cross-bars having divergent flanges *j*, and supported on the lower flanges of the beams, other cross-bars of like construction located above those on said beam-flanges and supported by standards *t* placed between and riveted to the members *c* of both upper and lower cross-bars and having foot-rests on the flanges of the floor-beams, the ceiling-slabs supported on the lower 110 cross-bars and the beam-filling slabs on the upper cross-bars substantially as described.

4. The combination with the floor-beams of sheet-metal cross-bars having divergent flanges *j*, and supported on the lower flanges 115 of the beams, other cross-bars of like construction located above those on said beam-flanges, and supported by standards *t* placed between and riveted to the members *c* of both upper and lower cross-bars and having 120 foot-rests on the flanges of the floor-beams, said standards also having the flanges *v* inserted in notches in the ends of said upper cross-bars under members *c*, the ceiling-slabs supported on the lower cross-bars and the 125 beam-filling slabs on the upper cross-bars substantially as described.

5. The combination with the floor-beams, of the cross-bars supported on the lower flanges of the floor-beams and supporting the 130 ceiling-slabs, the upper arched cross-bars supported on the standards fitted between

and riveted to the members *c* of said lower and upper cross-bars, and having foot-rests on the beam-flanges, and the bars A^2 placed between and supported at their ends on the 5 said arched cross-bars and having the beam-filling tiles supported on their flanges *j*, substantially as described.

Signed at New York city, in the county and State of New York, this 1st day of June, A. D. 1896.

ELOF R. LEONARD.

Witnesses:

W. J. MORGAN,
A. P. THAYER.