

A. Ball,

D., Sheets, Sheet 1

Rock Drill.

No 112,885.

Patented Mar. 21, 1877.

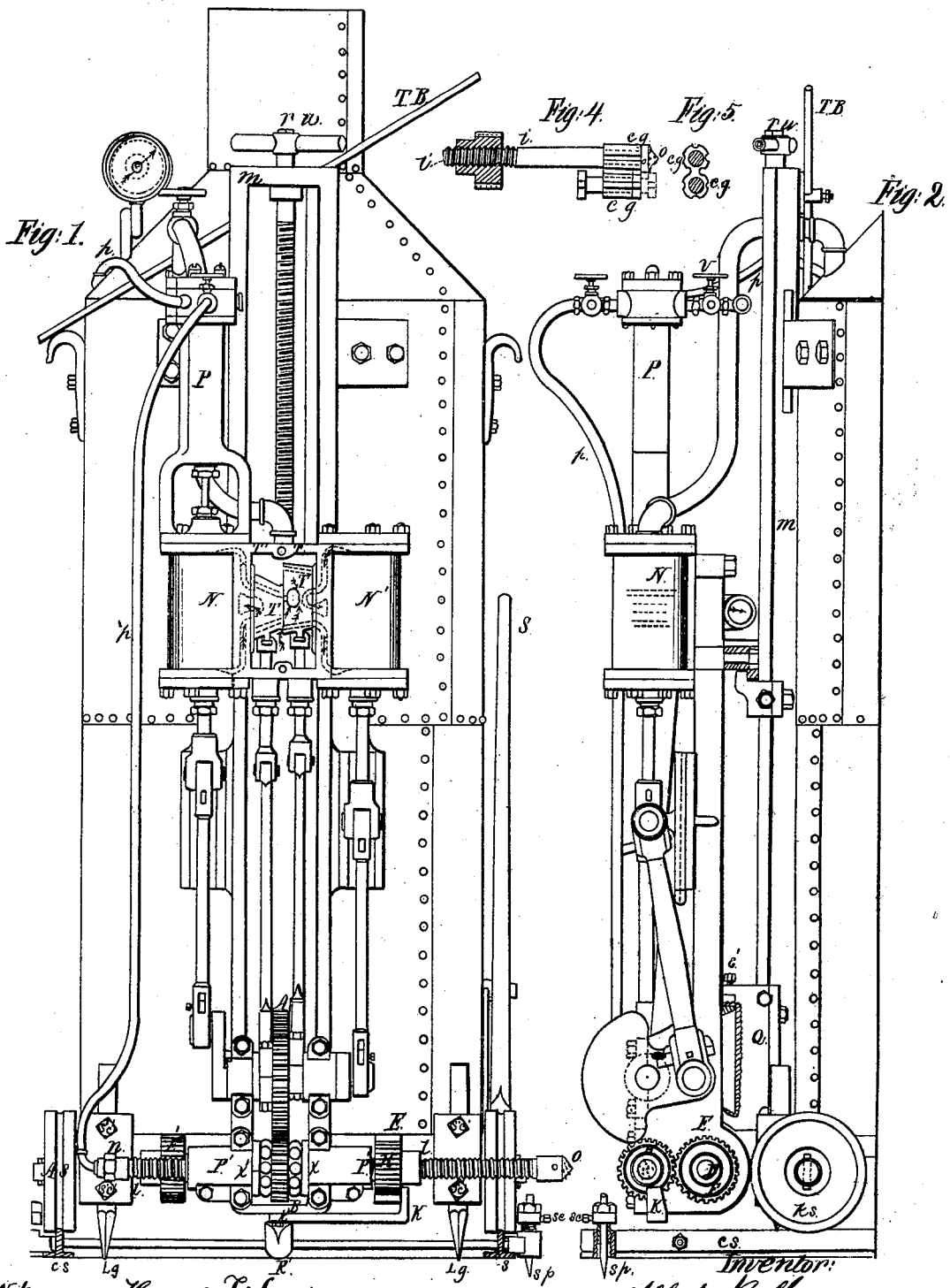

Witnesses: Horace Deane
A. N. Quinn

Inventor:
Albert Ball

A. Ball,

Rock Drill.

No. 112,885.

Patented Mar. 21, 1871.

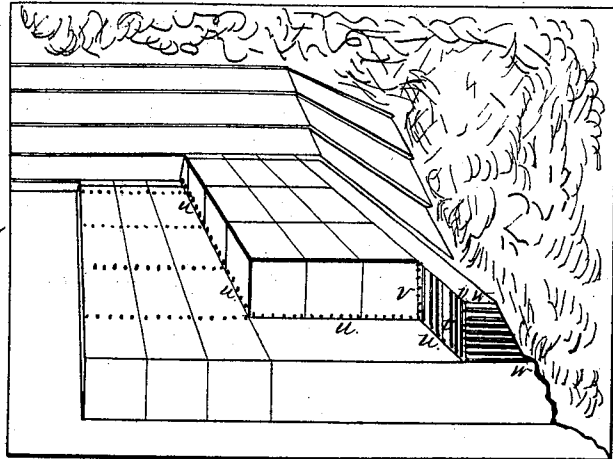

Fig. 5.

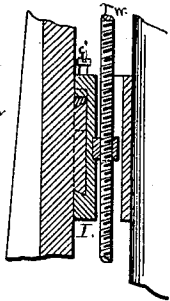

Fig. 8.

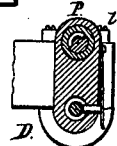

Fig. 7.

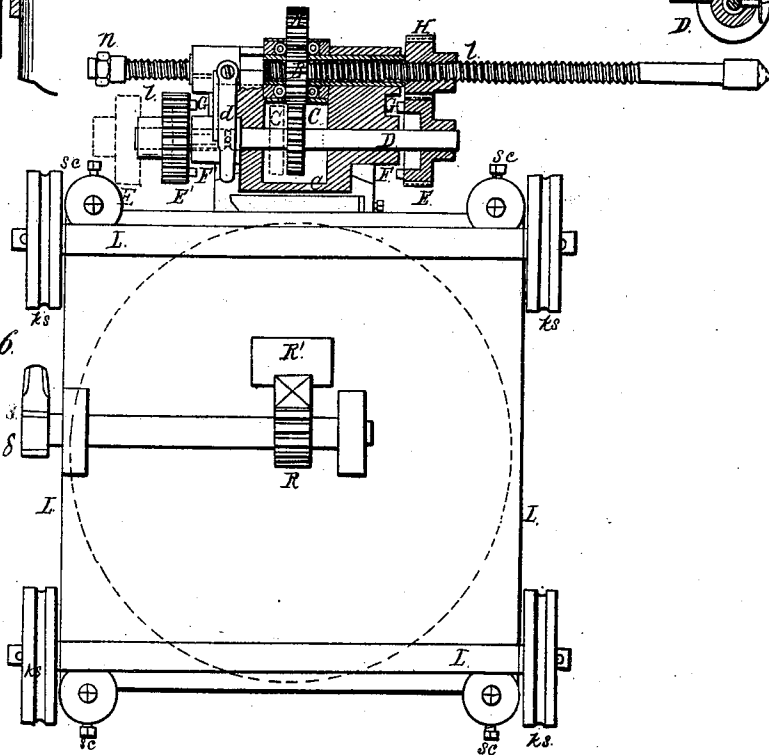

Fig. 6.

Witnesses:
 M. H. Clarke
 Horace Stone

Inventor:
 Albert Ball.

United States Patent Office.

ALBERT BALL, OF CLAREMONT, NEW HAMPSHIRE, ASSIGNOR TO SULLIVAN MACHINE COMPANY, OF SAME PLACE.

Letters Patent No. 112,885, dated March 21, 1871.

IMPROVEMENT IN ROCK-DRILLS.

The Schedule referred to in these Letters Patent and making part of the same.

I, ALBERT BALL, of the town of Claremont, county of Sullivan and State of New Hampshire, have invented certain Improvements in Machines for Drilling or Boring Rock, Marble, and similar substances; and I declare the following to be a full and exact description thereof.

My invention consists—

First, in devices for adjusting and securing the machines in a working position; and

Second, in devices for regulating the feed and the reverse movements of either a right or left-hand spindle.

In the drawing filed herewith—

Figure 1, plate 1, represents a front view of a machine embodying my invention.

Figure 2, plate 1, a side view of said machine.

Figure 3, plate 2, an interior view of a quarry, showing various directions in which to drill or bore in order to take out blocks of stone or marble.

Figure 4, plate 1, a side view of the drill-head used with section of left-hand screw-spindle, and of nut-gear and a guide, to be used in boring one hole so as to intersect another hole already bored.

Figure 5, plate 1, an end view of the guide.

Figure 6, plate 2, a bottom view of platform and boring apparatus.

Figure 7, plate 2, a side view of the spring-bolt *d* and a transverse sectional view of shaft *D* and drill-spindle *l*.

Figure 8, plate 2, a transverse vertical section of the swivel *Q*, and also shows the guide-bar *m* and set-screw *e*.

In the drawing the same letters represent corresponding parts of the machine.

L is the platform or pedestal of the machine.

It is provided with trucks, *k s*, which are arranged to run upon the track or rails *c s*.

The track or rails are used to facilitate moving the machine in order to bore a series of holes like *u u u*, shown in fig. 3, plate 2.

The platform *L* is also provided with the rack-pivot, *B*, the lever *S*, and the adjustable legs *L g*, with the set-screws *s' e'*, figs. 1 and 6.

When the machine is at the desired position on the track or rails, then, by the lever *S*, the rack-pivot *B* is pushed down to the bed or surface below the track so as to raise the machine slightly, and the machine is then adjusted to the proper position for working by means of the adjustable pointed legs *L g* and the set-screws *s' e'*.

The machine, when in operation, should always rest upon the legs *L g*, and not upon the trucks or track. This is to obviate the slight disturbing motion that would result if the machine, when at work, rested upon the trucks and track.

The drawing shows a small upright boiler set upon

the platform, which is used to support the boring apparatus and to ballast the machine as well as to generate steam.

In place of the boiler it is obvious that a suitable frame may be set upon the platform by which to support the boring apparatus.

m is a guide-bar secured to the boiler. By this guide-bar the boring apparatus is supported.

Q is a swivel;

r w, an adjusting-screw; and

e', a set-screw.

The box containing the swivel *Q* is so constructed and fitted to the guide-bar *m* and the adjusting-screw *r w* that, by means of the screw *r w*, it may be raised or lowered at pleasure within grooves in the guide-bar *m*. By this operation the boring apparatus, which is attached to the swivel *Q*, is also raised or lowered, as may be desired, and the boring operation may thus be conducted with the boring apparatus secured at any point desired upon the guide-bar *m*.

The swivel *Q* and the boring apparatus are held in position by the set-screw *e'*. By loosening the set-screw *e'* the boring apparatus may be turned upon the swivel *Q* and set so as to bore in any direction within the plane of the swivel-plate.

N N' is a double-cylinder steam-engine.

T T are the valves of the steam-engine.

P, above the steam-engine, is a pump worked by the steam-engine, and supplying water to the boiler by the flexible pipe *p*, and to the drill-spindle, which is tubular, and drill-head, by the flexible pipe *p'*.

e' is a gauge-valve for regulating the supply of water.

In the drill-head there are several small apertures, *o o*, through which the water thus supplied is forced, and in this way the detritus made in the operation of boring is removed.

T B is a brace by which the upper part of the machine may be secured to the wall of the quarry, or to any other object at hand.

A is the driving-wheel of the machine, driven by the steam-engine *N N'*, or by power furnished in any other well-known way.

B is a gear-wheel driven by *A*.

C is a feed-gear wheel worked by the gear-wheel *B*, fig. 6, plate 2.

The gear-wheel *C* is hung at the middle of the shaft *D*.

The shaft *D* carries at one end the clutch-gear wheel *E*, and at the other end the clutch-gear wheel *E'*.

The shaft *D* is held in position by the spring-bolt *d*, figs. 6 and 7, plate 2. By relieving the pressure of the bolt *d* upon the shaft *D* the shaft *D* may be moved, so as to throw, in either direction, the feed-gear *C* in or out of gear with the wheel *B*, at pleasure.

In fig. 6, plate 2, *B* and *C* are in gear. The dotted lines show *B* and *C* out of gear in one direction.

F and F' are clutches on the inner faces of the wheels E and E'.

When the wheels B and C are out of gear in one or the other direction, either F or F' clutches with the rests G or G', and thereby the further movement and the revolutions of the shaft D are checked.

The wheels E and E' gear with corresponding nut-gear wheels H and H', within which the drill-spindles run.

The faces of the wheels E and E' are made wider than the faces of the wheels C and B, in order that E or E' may always remain in gear with the nut-gear H or H', while, by the sliding movement of the shaft D, the wheel C is thrown in or out of gear with the wheel B.

The machine is furnished with two drill-spindles, *l*, fig. 1, plate 1, and *l'*, fig. 4.

l has a right-hand screw-thread cut upon it, which engages with the internal screw-thread of the nut-gear H.

Fig. 1 shows *l* adjusted for work in the machine.

l' has a left-hand screw-thread cut upon it, which engages with the internal screw-thread of the nut-gear H'.

On displacing the drill-spindle *l* the drill-spindle *l'* may be set for work in the same drill-spindle holder P' P'.

Its drill-head, however, should point in the direction opposite to that of drill-head of spindle *l*.

K is a lock-bar, figs. 1 and 2, hung on a pivot, *k*, in such way that it may be swung round, so as to hold in position either the nut-gear H or H', whichever one may at the time be in use.

x x' are sets of anti-friction rollers placed on both sides of the gear-wheel B, to relieve the sides of the wheel B from friction as the right or left-hand spindle may be operated.

Any suitable form of rotary drill-bit or head may be operated by this machine. I prefer, however, to use the drill-head set with black diamonds, patented by Grier & Boyd, dated May 23, 1865, and reissued to Horace T. Love on September 29, 1868.

For boring marble, rock, or similar substances, the machine, when properly set and braced, is operated as follows:

Fig. 1 shows the right-hand drill-spindle ready to be operated, and I now describe the boring operation of the machine set with the right-hand drill-spindle.

The driving-wheel A turns the wheel B, and the wheel B engages with and turns the wheel C, the shaft D, and the wheel E; the wheel E engages with and turns the nut-gear wheel H. The wheel E has sixteen cogs; the nut-gear H has fourteen cogs; H, therefore, makes eight revolutions while E makes seven revolutions. The wheel B has sixteen cogs.

The internal screw-thread of the nut-gear wheel H engages with the screw-thread of the drill-spindle *l*.

The drill-spindle is, therefore, fed forward the distance of one of its threads in every eight of the revolutions of the nut-gear wheel H, and in every seven of the revolutions of the wheel E.

To effect the reverse movement of the drill-spindle *l* the lock spring-bolt *d* is pressed down so as to release the shaft D. The shaft D is then moved to the left, as shown by the dotted lines, until the wheel C is out of gear with the wheel B and the clutch F' catches the rest G. The wheel E and the nut-gear wheel H are thus held at rest while the revolutions of the wheel B and the drill-spindle *l* continue. The lock-bar K now prevents the nut-gear H from running down the thread of the spindle *l*. The result is a reverse movement of the spindle *l* at the rate of the distance of one thread of the spindle *l* to every revolution of the wheel B.

The left-hand drill-spindle *l'* is obviously operated in a similar way, but in the opposite direction.

I thus have a machine relatively light, compact, easily handled, and well adapted to boring or drilling in mines, quarries, and for the purpose of blasting, and of especial value in that class of work in quarries known as "gadding," hitherto done wholly by hand labor.

By my machine holes are bored in marble at the rate of from four to five inches per minute, and in iron ore at the rate of from two to three inches per minute.

What I claim as my invention, and desire to secure by Letters Patent, is—

1. The combination of the rack-pivot R', operated by the pinion R and lever S, with the platform L and the adjustable legs Lg, substantially in the manner and for the purpose set forth.

2. The wheels B and C, combined with the sliding shaft D and the wheels E and E', so as to operate the wheel E and the nut-gear H, in order to feed the right-hand spindle *l* in one direction, or so as to operate the wheel E' and the nut-gear H', in order to feed the left-hand drill-spindle *l'* in the opposite direction, substantially as hereinbefore described.

3. The sliding shaft D, wheels E and E', clutches F and F', rests G and G', the wheel B, and lock-bar K, so combined with a right or left-hand nut-gear and drill-spindle that when operated in the manner described they will reverse the movement of the drill-spindle, substantially as hereinbefore set forth.

4. The combination of the spring-bolt *d* and the shaft D, substantially as and for the purpose set forth.

5. The pivoted lock-bar K, combined with the nut-gears and spindles described, substantially as and for the purposes set forth.

ALBERT BALL.

Witnesses:

G. W. HOLDEN,
W. H. DELANO.