

Aug. 1, 1933.

K. L. McGLAUGHEN

1,920,580

CHILD'S BED

Filed Jan. 20, 1932

3 Sheets-Sheet 1

Fig. 1

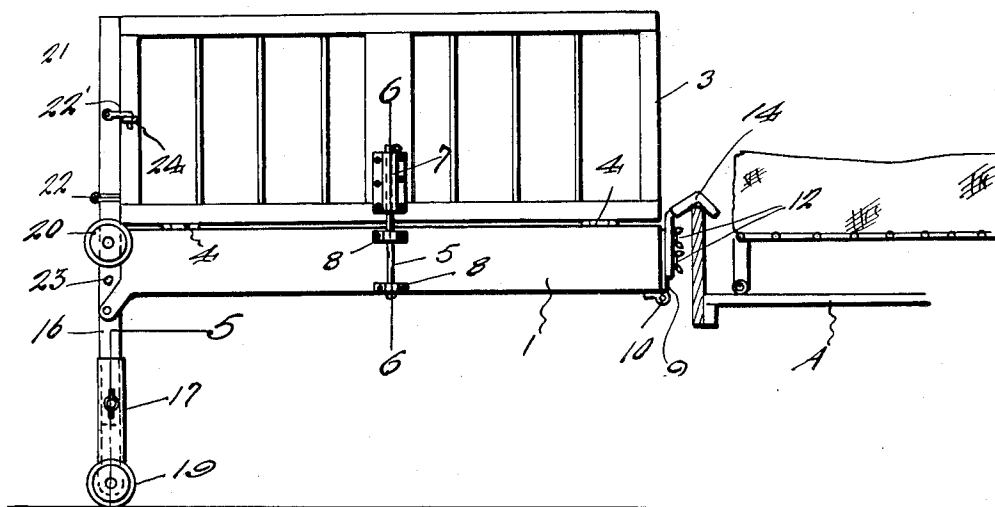
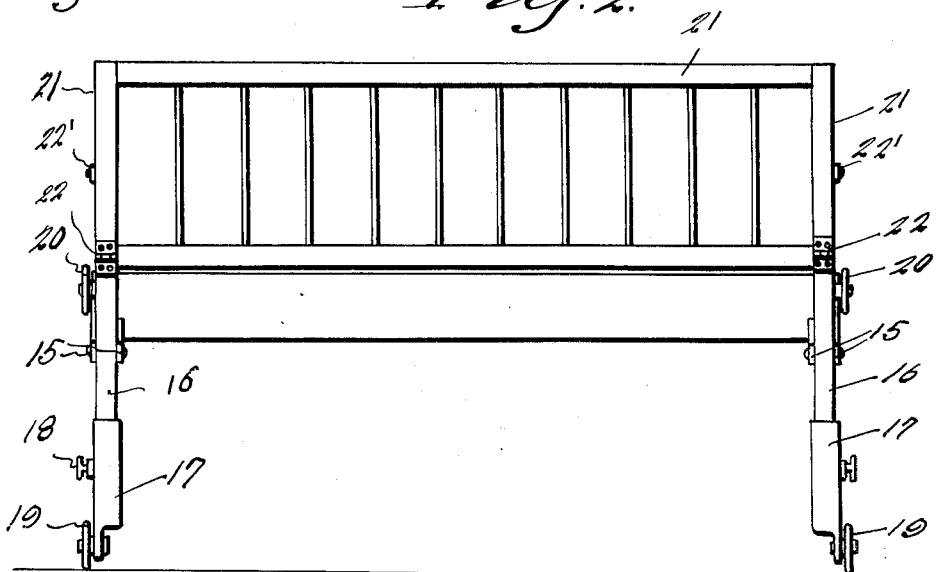

Fig. 2



Inventor

Katherine L. McLaughlen

By Clarence A. O'Brien
Attorney

Aug. 1, 1933.

K. L. McGLAUGHEN

1,920,580

CHILD'S BED

Filed Jan. 20, 1932

3 Sheets-Sheet 2

Fig. 3.

Fig. 10.

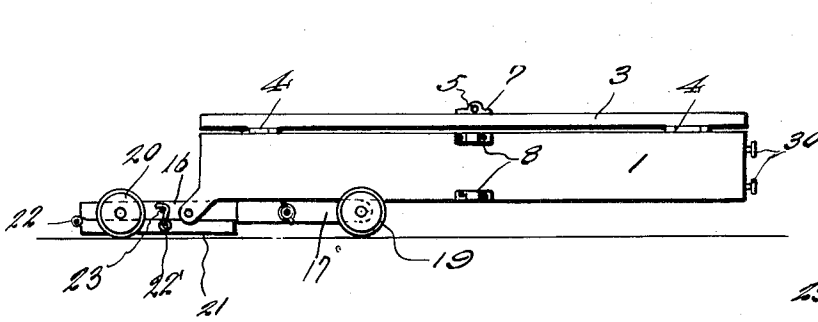

Fig. 4.

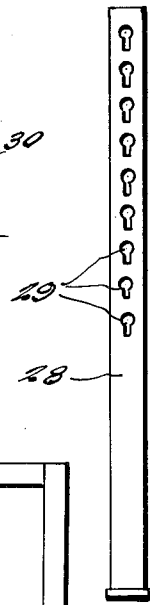
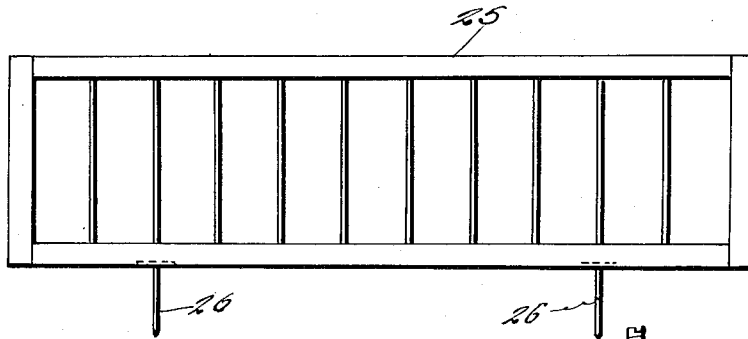

Fig. 5.

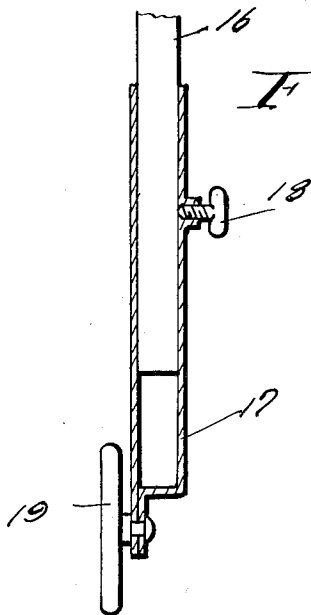
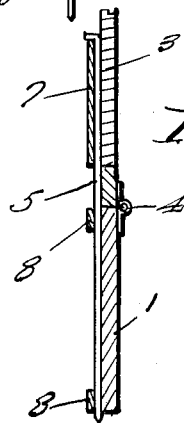

Fig. 6.



Inventor
Katherine L. McGlaughen

By *Clarence A. O'Brien*
Attorney

Aug. 1, 1933.

K. L. McGLAUGHEN

1,920,580

CHILD'S BED

Filed Jan. 20, 1932

3 Sheets-Sheet 3

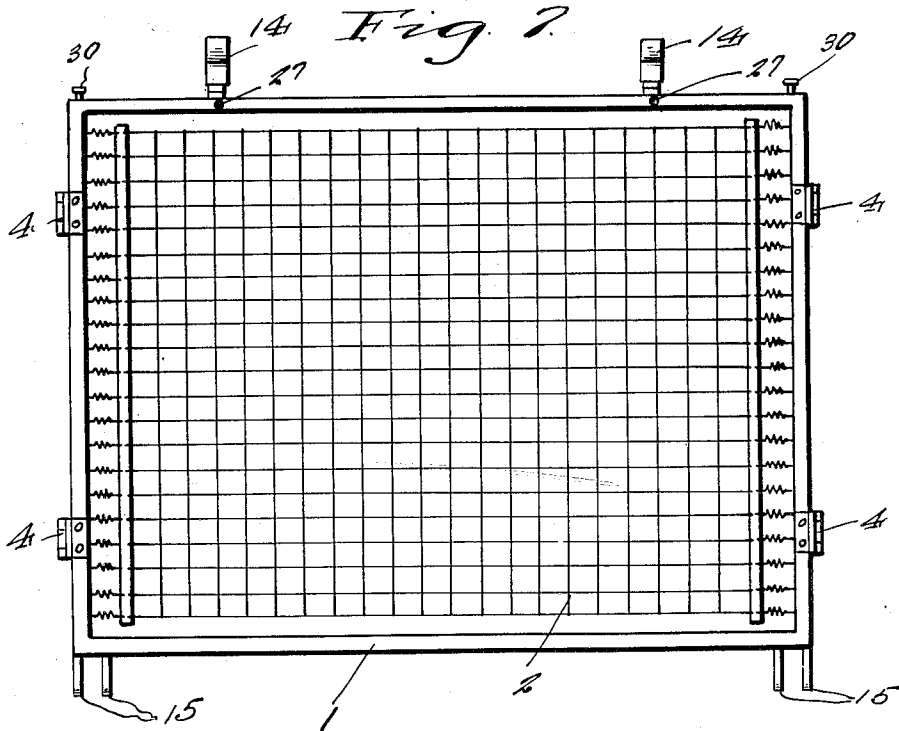

Fig. 8

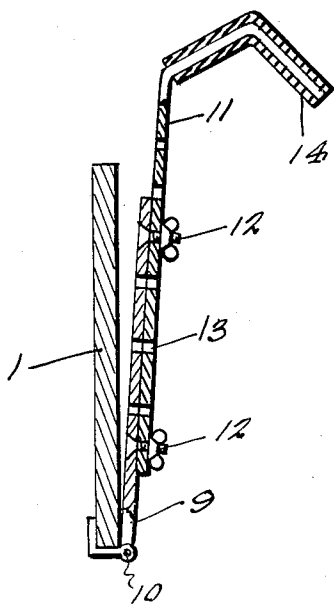
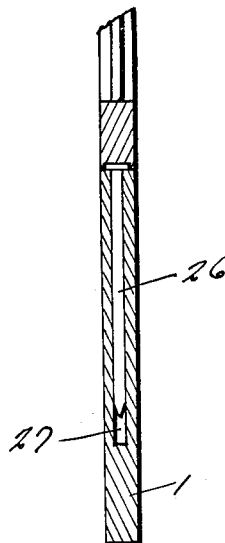

Fig. 9



Inventor

Katherine L. McLaughlen

By *Clarence A. O'Brien*
Attorney

UNITED STATES PATENT OFFICE

1,920,580

CHILD'S BED

Katherine L. McGlauthen, St. Louis, Mo.

Application January 20, 1932. Serial No. 587,797

1 Claim. (Cl. 5—99)

This invention relates to a bed for children, the general object of the invention being to provide means whereby the bed can be set up alongside of a large bed, and partly supported thereby, with means whereby the small bed can be folded, so that it can be rolled under the large bed and thus be out of the way when not in use.

Another object of the invention is to provide detachable legs so that the small bed can be supported by means of detachable legs and the foldable legs when desired.

This invention also consists in certain other features of construction and in the combination and arrangement of the several parts to be hereinafter fully described, illustrated in the accompanying drawings and specifically pointed out in the appended claim.

In describing the invention in detail, reference will be had to the accompanying drawings wherein like characters denote like or corresponding parts throughout the several views, and in which:—

Figure 1 is an end view showing the invention set up and partly supported by an ordinary bed, the ordinary bed being shown partly in section.

Fig. 2 is a view looking toward the outer side of the small bed.

Fig. 3 is a view showing the bed folded into position ready to be shoved under a large bed.

Fig. 4 is a view of the removable side member.

Fig. 5 is a section on line 5—5 of Fig. 1.

Fig. 6 is a section on line 6—6 of Fig. 1.

Fig. 7 is a bottom plan view of the small bed with parts removed.

Fig. 8 is a sectional detail view showing one of the adjustable hook members for supporting one part of the small bed from the large bed.

Fig. 9 is a detail sectional view showing how the removable side member is supported from the frame of the bed.

Fig. 10 is a view of one of the removable legs.

In these drawings the numeral 1 indicates the bottom or body part of the bed, which is made in the form of box open at its top and bottom and having the mattress supporting members shown generally at 2 stretched across its lower part so that when a mattress is placed on said member, the mattress will be located in the body 1. An end member 3 is hinged to each end of the body 1 as shown at 4, and each end member 3 is held in raised position by a bar 5 slidably supported in a tubular part 7, attached to the central part of the member 3 and adapted to pass through the brackets 8 at the central part of each end of the body 1. By lifting the rods 5, out of the bracket

8, the end members can be folded upon the bed clothing and the mattress to hold the parts in position.

A pair of members 9 is hinged to one side of the body, one adjacent each end of said side, as shown at 10, and a hook-shaped member 11 is adjustably connected to each member 9 by the bolts and thumb screws shown generally at 12, which are adapted to engage any desired pairs of holes 13 in said members 9 and 11, as clearly shown in Fig. 8.

The hooked part of each member 11 is covered by rubber or the like as shown at 14, and these hooked parts are adapted to engage the side of a bed A as shown in Fig. 1, so as to support this side of the small bed at the side of the large bed. Ears 15 extend downwardly and outwardly from the opposite side of the body 1, and a pair of legs 16 is pivoted to these ears. Each leg has a tubular part 17 forming its lower part which is adjustably connected to the upper part by a set screw 18 so that the length of the leg can be adjusted, and the lower end of the tubular part 17 carries a small wheel 19 which is located at one side of the leg as clearly shown in Fig. 5.

Another small wheel 20 is carried by the upper part of the leg above the point where the leg is pivoted to the ears so that when the leg is moved to a horizontal position as shown in Fig. 3, both wheels will engage the floor and thus permit the small bed to be rolled along the floor. The side member 21 of this side of the bed has its ends hingedly connected to the upper ends of the legs as shown at 22 so that this side member 21 can be folded downwardly against the legs as shown in Fig. 3. This side member 21 is held against the legs by the hooks 22' thereon, engaging projections 23 on the legs and when in raised position, these hooks engage eyes or projections 24 on the end members 3 to hold the side member 21 and the legs in raised position.

The other side member 25 has its lower edge provided with pins 26 engaging sockets 27 formed in the upper edge of that side of the body 1 which is located adjacent the bed A. Thus whenever desired this side member 25 can be used to hold the child in the bed or can be removed, so that a person in the large bed can have access to the child in the small bed.

I also provide a pair of detachable legs, one of which is shown at 28, in Fig. 10 for supporting that part of the body 1 to which the members 9 are connected, and when it is not desired to support the bed 1 from the bed A. Each leg 28 is formed with a vertical row of keyhole shaped

openings 29 for receiving headed studs 30 on the side of the body 1, so that these legs 28 are detachably connected by the studs 30 engaging some of the holes 29 to the leg 28. As will be seen, the shape of the holes 29 are such that the weight of the bed 1 will cause the shanks to be held with the lugs 30 in the small portions of the holes 29.

From the foregoing it will be seen that I have provided means whereby one side of the small bed can be supported from one side of the large bed so that the occupant of the large bed can take care or have access to an infant in the small bed and that whenever necessary, the side member 25 can be put in place so as to prevent an infant from crawling out of the small bed into the large bed.

It will also be seen that by unfastening the hook 21' and moving upwardly the rods 5, the end pieces 3 can be folded over upon the small bed to hold the clothing and the mattress in place and that the side member 21 can be folded upon the leg and fastened to the leg, and then the legs moved to horizontal position so that the rollers or wheels 19 and 20 will engage the floor, to permit the small bed to be rolled under the large bed or to any other location, as shown in Fig. 3.

It will also be seen that whenever desired, the legs 28 can be attached to the bed so as to support the same upon the floor by the four legs when it is not desired to support the bed by the large bed.

It is thought from the foregoing description that the advantages and novel features of the invention will be readily apparent.

It is to be understood that changes may be made in the construction and in the combination and arrangement of the several parts provided that such changes fall within the scope of the appended claim.

Having thus described my invention, what I claim as new is:—

A bed of the class described comprising a body, ears extending downwardly and outwardly from the corners of one side thereof, legs pivoted to the ears intermediate the ends of the legs, a tubular telescopic member on the lower end of each leg, means for holding said member in adjusted position, a wheel supported on a horizontal axis at the lower end of each tubular member, a wheel supported on a horizontal axis at the upper end of each leg, said wheels engaging a surface when the legs are moved to a horizontal position, with the wheels carried by the legs spaced outwardly from said side of the body and said tubular members being extended to place the wheels carried thereby at a point beyond the center of gravity of the body, whereby the body will be supported in stable position on the pairs of wheels without toppling over.

KATHERINE L. McGLAUGHEN.

35	110
40	115
45	120
50	125
55	130
60	135
65	140
70	145
75	150