

(No Model.)

4 Sheets—Sheet 1.

G. SAUTTER. ELECTRIC SEARCH LIGHT.

No. 454,604.

Patented June 23, 1891.

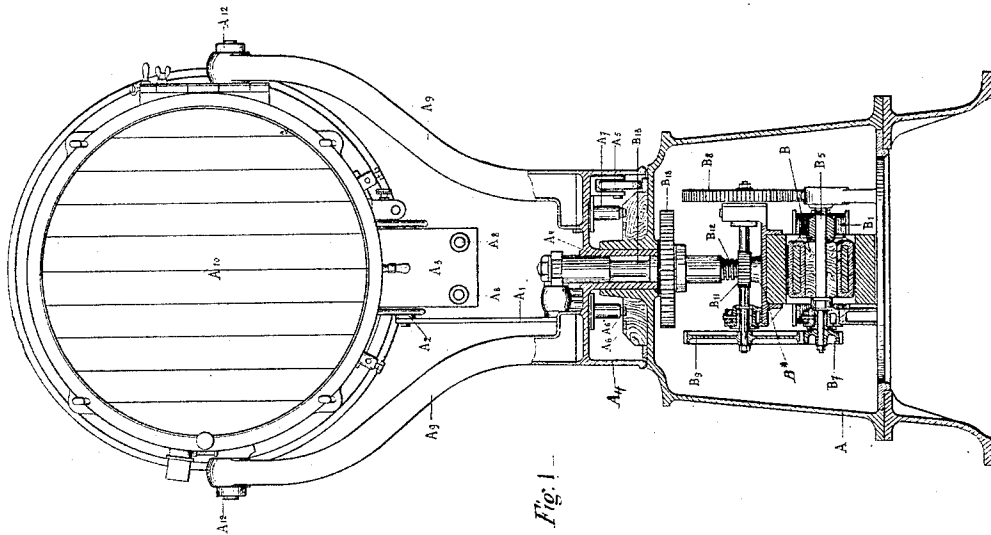
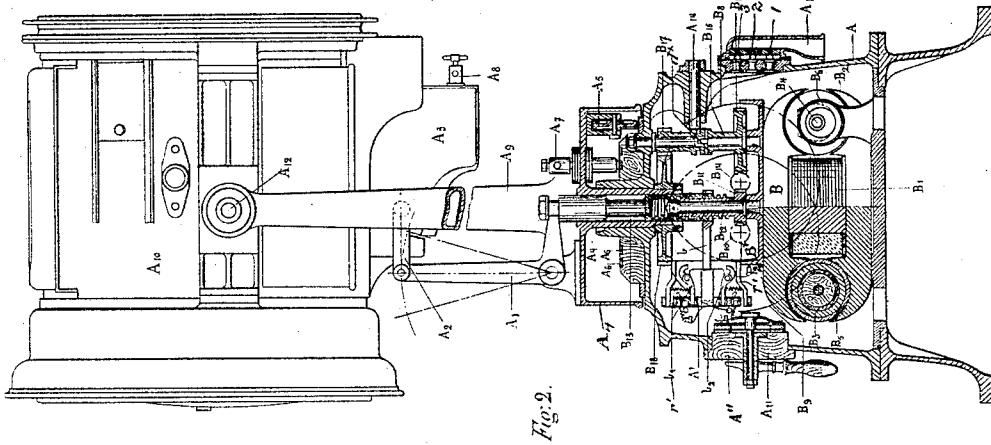

Attest
Jonas S. Kelley
Esq.

Inventor
Gaston Sautter by
Pollock, Mauro & Co.
 Attorneys.

(No Model.)

4 Sheets—Sheet 3.

G. SAUTTER.
ELECTRIC SEARCH LIGHT.

No. 454,604.

Patented June 23, 1891.

Fig. 10.

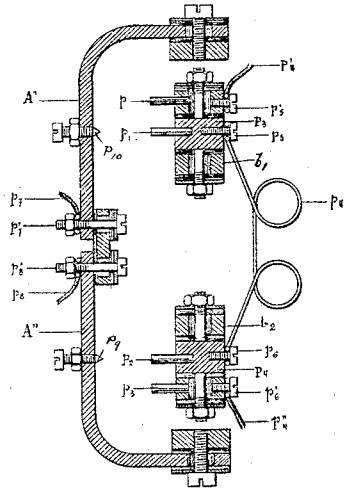

Fig. 11.

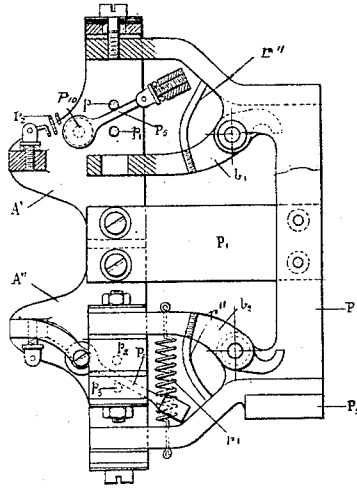
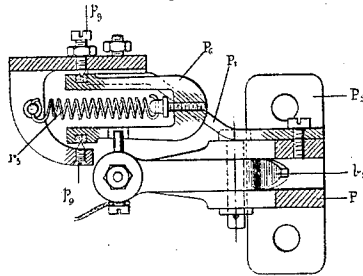

Fig. 12.



Attest.
Jona B. Kelley.
L. McKinley

Inventor
Gaston Sautter by
Pollock & Mauro his
attorneys

G. SAUTTER.
ELECTRIC SEARCH LIGHT.

No. 454,604.

Patented June 23, 1891.

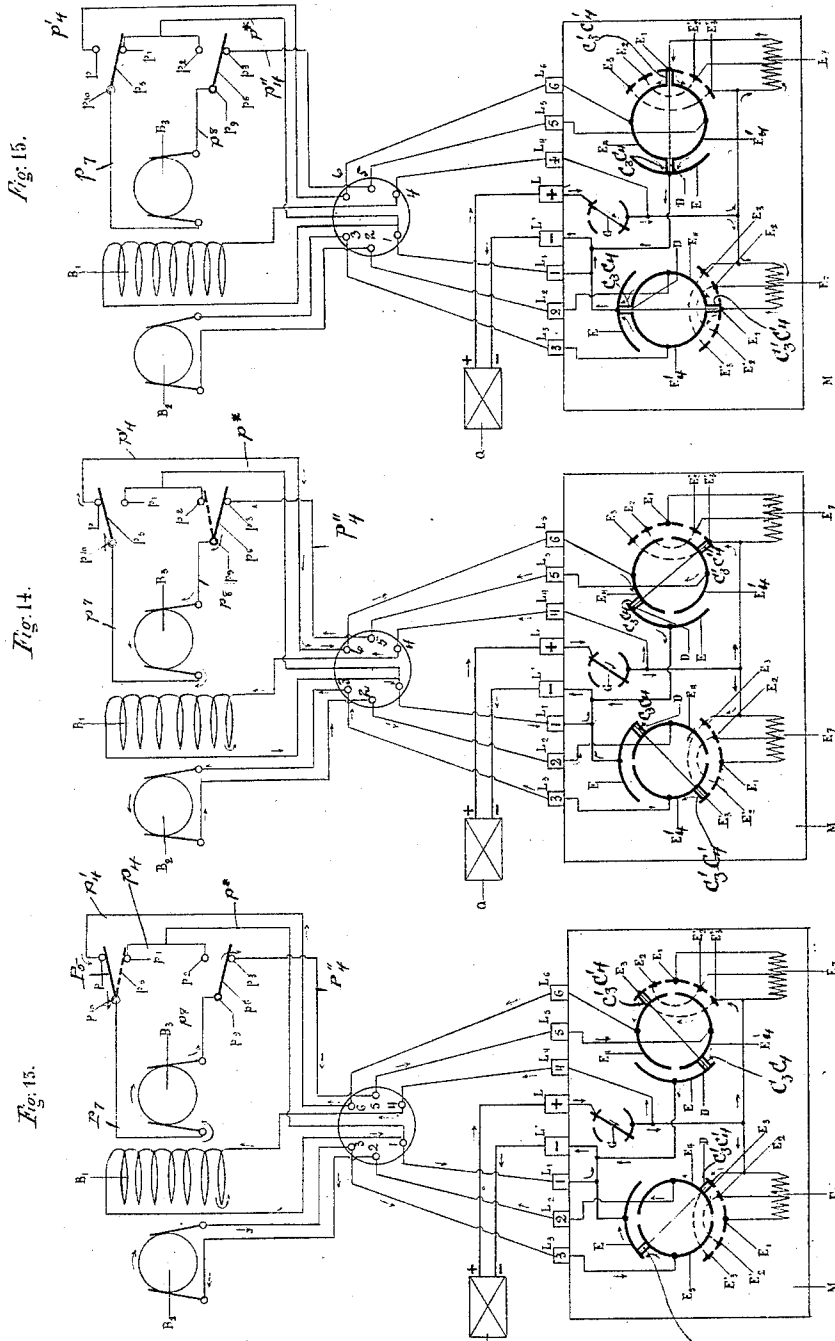

Attest.
James H. Kelly
G. M. Kelley

Gaston Sautter Inventor
by
Pollok & Mauro Attorneys.

UNITED STATES PATENT OFFICE.

GASTON SAUTTER, OF PARIS, FRANCE, ASSIGNOR TO SAUTTER, HARLÉ & CO.,
OF SAME PLACE.

ELECTRIC SEARCH-LIGHT.

SPECIFICATION forming part of Letters Patent No. 454,604, dated June 23, 1891.

Application filed February 27, 1891. Serial No. 383,128. (No model.) Patented in France August 16, 1890, No. 207,659.

To all whom it may concern:

Be it known that I, GASTON SAUTTER, a citizen of France, residing at 26 Avenue Suffren, Paris, France, have invented certain new and useful Improvements in Machinery for Directing Search-Lights, (for which Letters Patent have been secured in France on the 16th of August, 1890, No. 207,659;) and I do hereby declare the following to be a full, clear, and exact description of the invention, such as will enable others skilled in the art to which it appertains to make and use the same.

This invention relates more particularly to machinery for directing search-lights from a distance by means of electricity; but each of the improvements constituting the said invention is included for all the uses to which it may be adapted.

On war ships and in fortresses it is important that the commanding officer may be able himself to direct the luminous beam while he observes the distant illuminated objects. To accomplish this it is desirable to start and stop the search-light or projector instantaneously; to produce a slow movement thereof through as small an angle as desired; to produce a rapid movement thereof at will; to direct the movement thereof in the direction both of azimuth and altitude; to stop the search-light or projector automatically at the limit of its vertical movement; to give a retrograde movement to the search-light or projector by a single movement of the switch after it has stopped itself automatically. By the aid of the present invention these results may be attained and an efficient apparatus produced capable of direction by a commanding or observing officer at a distance. In accordance with said invention the search light or projector mounted in altitude is connected mechanically with two electric motors, one for giving the movement in altitude and the other in azimuth, and with each motor is combined a controlling-switch whereby said motor can be rotated in either direction and stopped and started at will. A special improvement in the stopping consists in arranging the controlling-switch so as to short-circuit the motor, which thereupon arrests itself instantaneously by the reaction of the current which

it generates in the short circuit. In order to convey the movements to the search-light from the motors, the said light is mounted by means of trunnions on a turn-table which is revolved by one motor to give the movement in azimuth, and the movement in altitude is imparted through a swivel-joint in the axis of the turn-table through devices to which a transverse movement is imparted by the other motor. In order to stop the movement in altitude automatically, circuit-changers are arranged in the path of a correspondingly-movable device, so as to be struck thereby and operated to change the circuit. While not restricting the invention absolutely thereto it is considered advantageous to employ such switches for the circuit-changers, so that the alteration is instantaneous, and also to arrange the circuits and circuit-changers in such a way that the motor is short-circuited by automatic operation of said circuit-changers, and these features are specially included in the invention.

A special new form of snap-switch has also been designed for use in the present invention. It will be hereinafter explained. In connection with the automatically-operated circuit-changers an arrangement of circuits and contacts is provided whereby the search-light may at once be moved both up or down, as the case may be. The circuit-changers reset themselves automatically.

The invention also comprises particular constructions, combinations, and arrangements of parts in the controlling-switch and also in the search-light, as hereinafter set forth.

In the accompanying drawings, which form part of this specification, Figures 1 and 2 are sectional elevations in planes at right angles to each other of a search-light. Figs. 3 and 4 are a partial sectional and partial face view of the controlling-switch for one motor. Figs. 5 and 6 are a face view and a cross-section, respectively, of the controller, which comprises switches for both motors. Figs. 7, 8, and 9 are detail views in section of one of the switches. Figs. 10, 11, and 12 are detail views of the automatic circuit-changers; and Figs. 13, 14, and 15 are diagrams of the circuits under different conditions of working or arrest.

The search-light in the form of an electric lamp is contained in the drum A¹⁰, which has a depending compartment A⁸, with binding-posts A⁸ for the feeding-wires. It is mounted on trunnions A¹² on the posts A⁹, which project upward from the turn-table A⁴. This table runs on rollers A⁵ and has a hollow central arbor, on the lower end of which is the spur-wheel B¹³ for giving the said turn-table and the search-light thereon the requisite motion in azimuth.

The search-light and its turn-table are supported on the hollow base A, in which are the motors and connecting mechanism for imparting movement thereto, and also the automatic circuit-changers. The drum A¹⁰ is oscillated on its trunnions through the lever A', fulcrumed on the turn-table A⁴ and connected by the link A² with the said drum, and connected also by a swivel-joint with the transversely-movable rod B¹³ in the hollow arbor of the turn-table. This swivel-joint, being in the axis of the turn-table, does not interfere with the rotation thereof. The rod B¹³ is bored and threaded at its lower end to form a nut, which engages the screw B¹² on the elongated hub of the worm-wheel B¹¹. This last turns loosely on a vertical stud, as shown in Fig. 2. By turning the worm-wheel B¹¹ and screw B¹² in one direction or the other the rod B¹³ is raised or lowered, thereby rocking the lever A and oscillating the drum A¹⁰ on its trunnions A¹². The wires for feeding electricity to form the arc of the search-light extend from the binding-posts A⁸ to the posts A⁷ on the turn-table, one of which rubs over the contact-ring A⁶ and the other over the contact-ring A⁷, which form the terminals of the feeding-circuit. The rotation of the turn-table A⁴ therefore does not affect the supply of electricity to the lamp in drum A¹⁰. At A¹¹ is a hand-switch for making and breaking the feeding-circuit of said lamp. The motors to traverse the search-light and to elevate and depress its beam comprise the armatures B² and B³, whose field-magnets are in one piece and magnetized by the coil B common to both. The shaft B⁴ of the armature B² carries a pinion B⁶, which engages the spur-wheel B⁸, whose shaft carries a screw B¹⁴, Fig. 2, engaging the worm-wheel B¹⁵, that turns loosely on the pin B¹⁶, and carries with itself the pinion B¹⁷, engaging the spur-wheel B¹⁸, already mentioned. As the armature B² revolves, therefore, its motion is suitably reduced and transmitted to the spur-wheel B¹⁸ and turn-table A⁴, so as to direct the search-light to any point of the horizon. This pinion B¹⁷ and the worm-wheel B¹⁵ would be formed integral or be rigidly connected; but for the purpose of enabling the disengaging of the driving-machines, and thus enabling the search-light to be turned by hand, the pinion B¹⁷ is driven through a clutch d⁸. By turning the rod A¹⁴ and lifting the pinion by means of the eccentric pin on the inner end of said rod (which pin enters a circular groove in the hub of pinion

B¹⁷) the pinion B¹⁷ may be disengaged from the worm-wheel B¹⁵. The shaft B⁵ of armature B³ carries a pinion B⁷, Fig. 1, which engages the spur-wheel B⁹, whose shaft carries a screw B¹⁰, engaging the worm-wheel B¹¹, that turns loosely on its central pin and revolves the screw B¹², above mentioned, so as to raise and lower the rod B¹³ and oscillate the drum A¹⁰.

At A' and A'' are two automatic circuit-changers, which are operated, respectively, by the arm b on the lower end of the rod B¹³ when the latter reaches the top or bottom of its course. As shown, (see Figs. 10, 11, and 12,) the circuit-changers A' and A'' are each mounted on, but insulated from, a bracket-frame of, say, bronze, composed of the arm P', upright P, and foot P², and secured by the last to the tray-like base-plate B⁶, Figs. 1 and 2, under the gearing above mentioned. The arm b acts upon one or the other of the levers b' b², which are held in their normal positions (shown in Figs. 2 and 11) by means of a spring r', in the form of a spiral tension-spring, and a stop r''. Each lever carries two contacts p p' and p² p³, respectively, in the form of pins of, say, silver fixed in holders of, say, bronze, insulated from each other, and the levers b' b² are provided with binding-posts p⁵ p'⁵ p⁶ p'⁶. The holders P³ P⁴ are provided with bolts, which pass through the holders for the pins p and p³, and are surrounded with insulating material. At p⁴ is a permanent electrical connection between the contacts p' and p². The pins p p' and p² p³ of each pair project on opposite sides of a switch-lever P⁵ P⁶, respectively, which is combined with a spring r² r³ for holding the switch-lever against one of the pin-contacts until said pin has moved it past the middle position, and for thereupon snapping the said lever into contact with the other pin of the pair: The switch-levers P⁵ P⁶ are each stirrup-shaped, (see Fig. 12,) and are mounted between centers p⁷ for the lower and p¹⁰ for the upper switch-lever, and the springs r² r³, in the form of spiral tension-springs, are placed in the bow of the stirrup, with one end fastened to the outer end of said stirrup and the other in a projection on the plate of the circuit-changer A' or A''. At p⁷ and p⁸ are electrical wires, which lead to the brushes of armature B³, and at p'⁴ p''⁴ are wires leading to binding-posts 6 and 5, (see Fig. 13,) to which wires for the distant controlling-switch for starting, stopping, and regulating the speed of motor B³ are led. The two middle pins p' p² are electrically connected with the binding-post 1. The field-coil B' is included in the loop between the posts 1 and 4 and the armature B² in the loop between the posts 2 and 3.

There is a controlling-switch for each motor. They may be alike. As shown in Figs. 3 to 9, they each comprise an upper set of contacts E¹ E² E³ E' E'² E'³ and a lower set of contacts E⁴ and E'⁴, both sets being secured by screws E⁵ to the non-conducting plate H

of, say, slate, in such a way as to insulate the contacts from each other. The conducting-block C^3 (of, say, copper) rubs over and establishes an electrical connection with the contact E. It is carried by the conducting leaf-spring F^1 , whose ends are fastened to but insulated from the rotating box C, of, say, bronze, which is turned by the handle D. The arbors C^* may be cast integral with the box C, and the upper of said arbors turns in a stationary bridge D' . The conducting-block C^4 rubs over and establishes an electrical connection with the contact E^4 or the contact E'^4 , according to the position in which it is placed, and said block is of such size that when it is in the middle position it establishes the electrical connection with both contacts E^4 and E'^4 , thus establishing a short circuit between them. The block C^4 is carried by a conducting leaf-spring F^3 , whose ends, like those of spring F^1 , are attached to but insulated from the box C. The blocks C^3 and C^4 are electrically connected with each other by means of the metallic pieces C' and C'' , so that the contact E is always in electrical connection with one or the other of the contacts E^4 or E'^4 , or with both. The conducting-block C^3 rubs over the contacts E^3 E^2 E' E'^2 E'^3 . It is carried by the conducting leaf-spring F^2 , whose ends are attached to but insulated from the box C. The conducting-blocks C^3 and C^4 are electrically connected with each other by the metallic pieces C^2 C'^2 , so that when said blocks are in the central position they put the contact E into electrical connection with both the contacts E^4 and E'^4 . When they are moved to the left, they successively put the contacts E' , E^2 , and E^3 in electrical connection with the contact E^4 , and when they are moved to the right they successively put the contacts E' , E'^2 , and E'^3 into contact with the contact E'^4 . The said apparatus therefore constitutes a reversing-switch, for if the current from the plus pole of an electrical generator be led to contacts E^3 E^2 E' E'^2 E'^3 and the contact E be connected with the minus pole of said generator while the contacts E^4 E'^4 are connected with the respective poles of a motor, then it is evident that as the handle D, box C, and the two pairs of blocks or rubbers—viz., C^3 C^4 and C'^3 C'^4 —are turned to the left, the current from the generator would pass to the motor by way of one of the contacts E' E^2 E^3 , block C^3 , spring F^2 , piece C^2 C'^2 , spring F^4 , block C^4 , and contact E^4 , and from the motor to the generator by way of the contact E'^4 , blocks C^4 , spring F^3 , pieces C' C'' , spring F^1 , block C^3 , and contact E. On the other hand, as the handle D and parts connected therewith are turned to the right the current for the generator would pass to the motor by way of one of the contacts E' E'^2 E'^3 , block C^3 , spring F^2 , pieces C^2 C'^2 , spring F^4 , block C^4 , and contact E'^4 , and from the motor to the generator by way of the contact E^4 , block C^4 , &c.

The object of using a number of contacts

E^3 E^2 E' E'^2 E'^3 is to enable the apparatus to serve as an adjustable rheostat or current-regulator. For this purpose resistances E^7 (see Figs. 13, 14, and 15) are placed between the contacts E' , and these are on one side thereof, the contacts on the opposite sides thereof being cross-connected—namely, E^2 with E'^2 and E^3 with E'^3 ; but the resistance-coils could be placed on both sides, as those skilled in electrical apparatus will readily understand.

The apparatus or controlling-switch, in addition to serving as a reversing-switch and current-regulator, is also a short-circuitor for the motor, as already explained.

In order to return the apparatus or controlling-switch to the middle position whenever it is released, a spring g , Figs. 3 and 8, (shown as a volute spring,) is interposed between two sleeves d^3 and d^2 inside the box C, the sleeve d^2 loosely surrounding the arbor C^* and having the inner end of the spring g attached thereto at f , and the sleeve d^3 being fastened inside the casing d , which itself fits loosely inside of the box C. With these parts are combined, first, a sector d' , Figs. 3 and 7, fastened by screws v to the box C; second, a sector d^5 , Figs. 3 and 9, fastened by screws v^3 to a stationary bottom c' ; third, a sector d^1 , fast on the sleeve d^3 at the top by being cast in one piece with the casing d ; fourth, a sector d^4 , fastened by screws v^2 to the sleeve d^3 and casing d at the bottom; fifth, a sector d'^2 , fast on the sleeve d^2 by being cast in one piece with said sleeve, and, sixth, a sector d^6 , fastened to the sleeve d^2 at the bottom by means of the screws v^4 . The spring g tends constantly to revolve the sleeves d^2 and d^3 in opposite directions. This movement of each sleeve is of course arrested so soon as the bottom sectors d^4 and d^6 (see Fig. 9) strike against the stationary sector d^5 . In this movement each top sector presses against the sector d' , which is brought to the middle position, as indicated in Fig. 7, and brings with it the handle D, box C, and springs F^1 F^2 F^3 F^4 , and blocks C^3 C^4 C'^3 C'^4 . When therefore the handle D is released, the spring g returns the controlling-switch to the middle position. The sectors permit, however, a movement to the right or left by application of a sufficient force to overcome the resistance of the spring g . When the handle D is turned to the left, the sector d' presses against the sector d'^2 and carries around the sleeve d^2 against the resistance of the spring, the sector d^5 acting as a fixed stop to prevent the sleeve d^3 and casing d from following, while the sector d^6 is free to move away from the said stop d^5 . On the other hand, when the handle D is turned to the right the fixed stop d^5 arrests the movement of the sleeve d^2 , while the sector d' carries the sleeve d^3 and casing d along with the handle D and box C. All the sectors may be described as stops or mechanical contact-pieces.

At G is a simple hand-switch for making or

breaking the circuit from the generator Q, Figs. 13, 14, and 15, which is placed in a loop between the binding-posts L L', the switch G being placed in the wire which leads from the post L. After passing the switch G the circuit branches right and left to the two controlling-switches, being directly in electrical connection with the contacts E³ E'³ of each switch and with the contacts E², E'², and E'⁷ through one or two of the resistances E⁷. These resistances can be adjusted as may be desired. By cutting out said resistances or connections in one or more of them the intensity of the current, and consequently the speed of the motor, can be varied. The left-hand switch controls the motor-armature B². Its contacts E³ E'² E' E² E³ are in electrical communication with the plus pole of the generator Q, as just described. Its contact E is in electrical communication with the minus pole of said generator Q by way of the post L'. The contact E⁴ is in electrical communication with one brush of the armature B² by way of the binding-post L² and 2 and the contact E⁴ by way of the posts L³ or 3 with the other brush of said armature. The circuit through the field-coil from the generator Q is by way of the post L, switch G, post L⁴, post 4, coil B, post 1, post L'', and post L'. The right-hand switch controls the motor-armature B³. Its contacts E³ E'² E' E'² E'³ are in electrical communication with the plus pole of the generator Q, as above described. Its contact E is in electrical connection with the minus pole of the generator Q by way of the post L'. The contact E⁴ of the right-hand switch is in electrical communication with one brush of the armature B³ by way of the posts L⁵ and 6, contact p, lever P⁵, wire p⁴, the contact E⁴ with the other brush by way of the posts L⁵ and 5, contact p³, lever P⁶, and wire p³.

The operation is as follows: Turning depending handle D of the left-hand switch to extreme right brings the blocks C³ C⁴ and C'³ C'⁴ to the positions shown in Fig. 13. The resistances E⁷ are thus cut out and the current passes by way of the contact E³, blocks C'³ C'⁴, contact E⁴, post L², posts 2, armature B², post 3, post L³, contact E⁴, blocks C³ C⁴, and contact E. The most intense current is sent into the armature B², which revolves therefore at the most rapid rate. The rotation of the armature B² revolves the screw B¹⁴, pinion B¹⁷, spur-wheel B¹⁸, and turn-table A⁴, so as to sweep the search-light rapidly around the horizon, the direction of the movement being determined by that of the armature B², which of course depends upon the winding, as well understood. It will be convenient, however, to make the winding such that the movement of the turn-table A⁴ will correspond as near as may be with that of the handle D. To reverse the movement of the turn-table A⁴, the depending handle D is swung to the left, thus putting the blocks C³ C⁴ and C'³ C'⁴ of the left-hand switch in the position shown in Fig. 14. The current passes by way of the contact E³ and cross-con-

nection to contact E'³, and thence by blocks C'³ C'⁴ to contact E⁴, post L³, post 3, motor-armature B², post 2, post L², contact E⁴, block C³ C⁴, and contact E. As the current flows through the armature B² in the opposite direction to what it did before and the field polarity remains the same, the armature B² rotates in the opposite direction and turns the turn-table A⁴ and search-light A¹⁰ also in the opposite direction. As the resistances A⁷ are cut out, the armature B² and the turn-table A⁴ are revolved at the highest speed. If a lower speed is desired, the depending handle D may be turned so as to bring the blocks C'³ C'⁴ opposite the contacts E² or E'², when one of the resistance-coils will be included. If a still lower speed is desired, the blocks C'³ C'⁴ may be brought opposite the end of the contact, thus bringing both resistances E⁷ in circuit; but if preferred the resistance between the contacts E' and E² may be so large that the current will be inconsiderable when said resistance is included in circuit. By placing the handle D in the middle position (or by releasing the handle and allowing it to be carried into the middle position by the spring g) the blocks C³ C⁴ and C'³ and C'⁴ then occupy the position shown in Fig. 15, and the circuit of generator Q is closed through the resistances E⁷, contact E', blocks C'³ C'⁴, contacts E⁴ E⁴, blocks C³ C⁴, contact E, while the armature B² is short-circuited through the post 2, post L², contact E⁴, blocks C⁴ and C'⁴, contact E⁴, post L³, and post 3. Whichever way the armature B³ may be revolving at this time, it sets up a strong current in the short circuit, whose reaction suddenly arrests the rotation of the said armature and the movement of the search-light, thus enabling the said light to be fixed on the spot desired without danger of being carried past it by the momentum of the machinery. The turn-table A⁴ may be revolved in either direction around the whole horizon. The right-hand switch controls the movement of the search-light in altitude. It is independent of that just described, and as shown in Fig. 6 the handle D projects horizontally. By moving this handle to the highest position the blocks C³ C⁴ and C'³ and C'⁴ occupy the positions indicated in Fig. 13. The current from generator Q passes by way of the post L, switch G, contact E'³, and cross-connection to the contact E³, (thus cutting out the resistances E⁷), and from the contact E³ it passes by the blocks C'³ C'⁴, contact E⁴, post L⁶, post 6, wire p⁴, pin-contact p, lever P⁵, wire p⁷ to one brush of the armature B³. It returns to the generator by way of the wire p³, lever P⁶, pin-contact p³, wire p⁷, post 5, post L⁵, contact E⁴, blocks C³ C⁴, contact E, and post L'. The passage of the current through the armature B³ revolves it, (say in the direction of the arrow,) which turns the screw B¹⁰, worm B¹¹, and screw B¹² in the direction to raise the nut-rod B¹³ and tilt the search-light upward. As the most intense current is on, this movement will proceed with

the greatest rapidity. The arm b rises with the nut-rod B^{13} , and when the latter approaches the top of its movement it strikes the inner end of the lever b' , and as said movement continues it turns the lever b' against the force of its spring r' and lowers the pins p and lever P^5 until the last-mentioned, having been carried past the horizontal, is in a position to be pulled down suddenly by the spring r^2 against the pin p' , as indicated in Fig. 13 by the dotted line. The supply-circuit of the armature B^3 is now interrupted, and said armature is short-circuited by way of pin-contact p' , wire p^* , post 1, post L'' , contact E of the right-hand switch, blocks $C^3 C^4$, contact E^4 , post L^5 , post 5, wire p'^4 , pin-contact p^3 , and lever P^6 . The rotation of the armature develops, therefore, a strong current, whose reaction quickly arrests the rotation, and the search-light comes to rest with the beam in its most elevated condition. By bringing down the handle D of the right-hand switch to the lowermost position the blocks $C^3 C^4$ and $C'^3 C'^4$ occupy the position shown at the right of Fig. 14. If the lever P^5 be on the contact p , as shown in Fig. 14, the current from contact E^3 passes by way of the blocks $C^3 C^4$, contact E^4 , post L^5 , post 5, wire p'^4 , pin-contact p^3 , lever P^6 , wire p^8 , armature B^3 , wire p^7 , lever P^5 , pin-contact p , wire p'^4 , post 6, post L^6 , contact E^4 , blocks $C^3 C^4$, and contact E . The rotation of the armature is therefore in the opposite direction from that indicated in Fig. 13; or, in other words, it moves the beam from the search-light downward. As the lower limit of the downward movement is approached, the arm B strikes the lever B^2 , and as the downward movement continues it raises the pins $p^3 p^2$ and the lever P^6 until the spring r^3 snaps the lever P^6 against the pin p^2 , as indicated by the dotted line in Fig. 14. The armature B^3 is now short-circuited by way of the pin p^2 , wire p^* , the post 1, post L'' , contact E , blocks $C^3 C^4$, contact E^4 , post L^6 , post 6, wire p'^4 , pin p , and lever P^5 , and the search-light is automatically stopped with the beam in its lowermost position. If when the handle D of the right-hand switch is drawn down the nut-rod B^{13} is at the top of its movement and the lever P^5 is resting against the pin p' , it is evident that the wire p'^4 will be out of circuit. In that case the current flows to the armature B^3 , as before described with reference to Fig. 14, but returns to the generator by way of the wire p^7 , lever P^5 , pin p' , wire p^* , post 1, post L'' , and post L' . As the rod B^{13} is carried down, the arm b retires from the lever b' , which is turned by the spring r until the lever P^5 is free to be snapped against the pin p , when the circuit is completed by way of the pin p'^4 , post 6, post L^6 , contact E^4 , block $C^3 C^4$, and contact E , and the current continues to flow in the direction to draw down the beam of the search-light. In like manner if the right-hand switch be reversed when the rod B^{13} is at the bottom of its course and the lever P^6 is against the pin

p^2 , as indicated by the dotted lines in Fig. 14, then the current will flow, as in Fig. 13, to the lever P^6 , but will complete the circuit by way of the wire p^* , post 1, post L'' , and post L' until the arm b has allowed the lever b^2 to be raised by its spring r' sufficiently for the spring r^3 to snap the lever P^6 against the pin p^2 , whereupon the whole circuit becomes as in Fig. 13. If a slower up-and-down motion is desired than would be given by the full current, the right-hand switch can be turned to bring the blocks $C^3 C^4$ opposite the contacts E^3 or E^2 or opposite the end of contact E' . To stop the search-light at any point in its up-and-down motion, the right-hand switch is placed in or allowed to assume the middle position. The armature B^3 is then short-circuited, and the reaction of the current set up in the short circuit quickly stops the said armature and the mechanism operated thereby. Should either of the levers P^5 be on the contact p' , then the short circuit would be as shown in Fig. 15—namely, by way of the wire p^8 , lever P^6 , pin p^3 , wires p'^4 , post 5, post L^5 , contact E^4 , blocks $C^3 C^4$, contact E , post L'' , post 1, wire p^* , pin p' , lever P^5 , and wire p' . If now the the lever P^5 be placed against the pin p , the short circuit will be completed from the contact E^4 by way of the blocks $C^3 C^4$ and $C'^3 C'^4$, contact E^4 , post L^6 , post 6, wire p'^4 , and pin p . If the lever P^6 be placed against the pin p^2 , the short circuit is formed by way of the wire p^* , post 1, post L , blocks $C^3 C^4$, contact E^4 , post L^6 , post 6, wire p'^4 , pin-contact p , lever P^6 . To cut off the current entirely, the switch G is turned.

While certain particular constructions of operating and controlling appliances for the search-light are described, it must be understood that the invention extends beyond such precise construction, so as not only to include such construction, but also switches, contacts, and other appliances in general, of which those shown may be taken as examples and illustrations.

I claim as my invention or discovery—

1. The search-light mounted to move in altitude and azimuth and provided with two motors in the base thereof, and intermediate mechanism whereby said light is moved in each of said directions by one of said motors, in combination with a controlling-switch for each motor, having an operating-handle, and comprising movable and opposing contacts relatively arranged and connected with said handle, as explained, so that the motor stops when the said handle is in the middle position and turns in one direction or the other as said handle is shifted to one side or the other of said middle position, substantially as described.

2. The combination, with the search-light mounted to move in altitude and azimuth and provided with motors and intermediate mechanism, of a controlling-switch for each motor, whereby the latter may be controlled

from a distance in its direction and speed of rotation or may be brought to rest, said switch having an operating-handle and a series of resistances, and comprising movable and opposing contacts relatively arranged and connected with said handle and resistances, as explained, so that the motor stops when the said handle is in the middle position and turns in one direction or the other as said handle is shifted to one side or the other of said middle position with a speed regulated by the distance to which said handle is shifted, substantially as described.

3. A controlling-switch comprising the switch-blocks or movable contacts, the opposing contacts, the rheostats, the double-acting spring, the stops, and the resistances, whereby said switch may send out a current of variable intensity in either direction and when released is automatically returned to the middle position, substantially as described.

4. A circuit-reversing switch having the contacts arranged to form a short circuit when the said switch is in the middle position, substantially as described.

5. A circuit-reversing switch having the contacts arranged to form a short circuit when said switch is in the middle position, and provided on either side of said position with a series of contacts and resistances for varying the intensity of the current, substantially as described.

6. A circuit-controlling switch comprising an upper and lower set of contacts, a box provided with a handle, conducting blocks and springs in said box, sleeves and springs in said box, and the sectors or stops, substantially as described.

7. A search-light mounted to move in altitude and provided with an electric motor and intermediate mechanism, and also with circuit-changers in the circuit of said motor adapted to be operated automatically when the limits of movement are attained, and when so operated to bring the motor and search-light to rest at the limit of the movement attained, substantially as described.

8. The combination, with a search-light mounted to move in altitude and provided with a motor and intermediate mechanism, and also with circuit-changers adapted to be operated automatically when the limits of movement are attained, of a controlling-switch provided with contacts, and electrical connections comprising a conductor intermediate the said circuit-changers and controlling-switch, normally out of contact but adapted

to be included by the automatic operation of said circuit-changers, so that when said circuit-changers have been operated the circuit may be reversed in said motor, substantially as described.

9. A search-light mounted to move in altitude and provided with a motor and intermediate mechanism and also with circuit-changers adapted to short-circuit the motor automatically when the limits of movement are reached, substantially as described.

10. An automatic circuit-changer, a motor, and a search-light moved thereby and adapted to operate the circuit-changer, in combination with a controlling-switch and electrical connections whereby said circuit-changer, when operated, establishes a short circuit on the motor through the said controlling-switch, substantially as described.

11. A circuit-changer comprising a lever, pin-contact carried by said lever, and a snap-switch lever between said pins, in combination with the search-light, electric motor, operating mechanism, and electrical connections, said snap-switch lever being adapted to be shifted at the limit of the search-light's movement by the action of said search-light on the first-mentioned lever, and to be automatically restored in the reverse movement of said search-light without altering the direction of the current in the motor, substantially as described.

12. A search-light mounted to move in altitude and azimuth and provided with a motor and intermediate mechanism to give motion in altitude and a motor and intermediate mechanism to impart motion in azimuth, and also with circuit-changers adapted to be operated automatically when the limits of the movement in altitude is reached and to be restored automatically in the reverse movement, in combination with a controlling-switch for each motor, and electrical connections whereby each switch may short-circuit its corresponding motor or may reverse the rotation thereof, the electrical connections for the altitude-motor comprising a conductor to the said automatic circuit-changers, through which said circuit-changers may establish a short circuit on the motor by way of the controlling-switch, substantially as described.

In testimony whereof I affix my signature in presence of two witnesses.

GASTON SAUTTER.

Witnesses.

G. DE MESTRAL,
ROBT. M. HOOPER.