

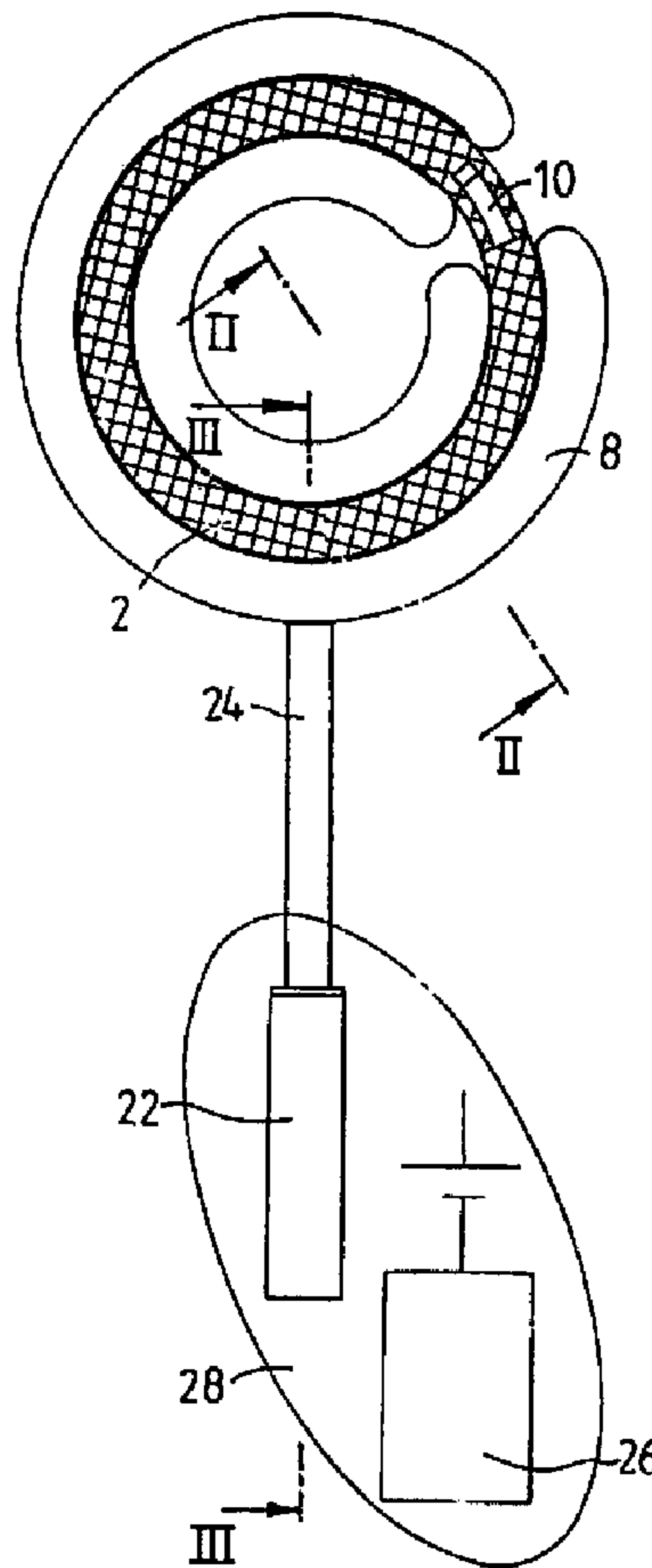

(86) Date de dépôt PCT/PCT Filing Date: 1999/08/12  
 (87) Date publication PCT/PCT Publication Date: 2000/02/24  
 (45) Date de délivrance/Issue Date: 2009/11/24  
 (85) Entrée phase nationale/National Entry: 2001/01/22  
 (86) N° demande PCT/PCT Application No.: SE 1999/001366  
 (87) N° publication PCT/PCT Publication No.: 2000/009048  
 (30) Priorité/Priority: 1998/08/13 (US09/133,319)

(51) Cl.Int./Int.Cl. *A61B 17/12* (2006.01),  
*A61F 2/08* (2006.01), *A61F 2/48* (2006.01)  
 (72) Inventeur/Inventor:  
FORSELL, PETER, CH  
 (73) Propriétaire/Owner:  
OBTECH MEDICAL AG, CH  
 (74) Agent: FETHERSTONHAUGH & CO.

(54) Titre : DISPOSITIF DE RESTRICTION D'INGESTION DE NOURRITURE  
 (54) Title: FOOD INTAKE RESTRICTION DEVICE



(57) Abrégé/Abstract:

A food intake restriction device for forming a stoma opening in the stomach or esophagus of a patient comprises an elongated restriction member (2), forming means (10) for forming the elongated restriction member into at least a substantially closed loop

(57) **Abrégé(suite)/Abstract(continued):**

around the patient's stomach or esophagus, so that the loop defines a restriction opening (3), and an adjustment means (12) for adjusting the restriction member in said loop to change the size of said restriction opening. A wireless remote control means is provided for non-invasively controlling the adjustment means (12) to adjust the restriction member (2), to thereby obtain a desired size of said restriction opening.

PCT

WORLD INTELLECTUAL PROPERTY ORGANIZATION  
International Bureau

## INTERNATIONAL APPLICATION PUBLISHED UNDER THE PATENT COOPERATION TREATY (PCT)

<p>(51) International Patent Classification <sup>6</sup> : <b>A61F 5/00</b></p>	<p><b>A1</b></p>	<p>(11) International Publication Number: <b>WO 00/09048</b></p> <p>(43) International Publication Date: 24 February 2000 (24.02.00)</p>
<p>(21) International Application Number: PCT/SE99/01366</p> <p>(22) International Filing Date: 12 August 1999 (12.08.99)</p> <p>(30) Priority Data: 09/133,319 13 August 1998 (13.08.98) US</p> <p>(71)(72) Applicant and Inventor: FORSELL, Peter [SE/CH]; Kirchgasse 4, CH-6313 Menzingen (CH).</p> <p>(74) Agents: HAGSTRÖM, Leif et al.; Bergenstråhle &amp; Lindvall AB, P.O. Box 17704, S-118 93 Stockholm (SE).</p>		<p>(81) Designated States: AE, AL, AM, AT, AU, AZ, BA, BB, BG, BR, BY, CA, CH, CN, CR, CU, CZ, DE, DK, DM, EE, ES, FI, GB, GD, GE, GH, GM, HR, HU, ID, IL, IN, IS, JP, KE, KG, KP, KR, KZ, LC, LK, LR, LS, LT, LU, LV, MD, MG, MK, MN, MW, MX, NO, NZ, PL, PT, RO, RU, SD, SE, SG, SI, SK, SL, TJ, TM, TR, TT, UA, UG, US, UZ, VN, YU, ZA, ZW, ARIPO patent (GH, GM, KE, LS, MW, SD, SL, SZ, UG, ZW), Eurasian patent (AM, AZ, BY, KG, KZ, MD, RU, TJ, TM), European patent (AT, BE, CH, CY, DE, DK, ES, FI, FR, GB, GR, IE, IT, LU, MC, NL, PT, SE), OAPI patent (BF, BJ, CF, CG, CI, CM, GA, GN, GW, ML, MR, NE, SN, TD, TG).</p> <p><b>Published</b> <i>With international search report. Before the expiration of the time limit for amending the claims and to be republished in the event of the receipt of amendments.</i></p>

(54) Title: FOOD INTAKE RESTRICTION DEVICE

## (57) Abstract

A food intake restriction device for forming a stoma opening in the stomach or esophagus of a patient comprises an elongated restriction member (2), forming means (10) for forming the elongated restriction member into at least a substantially closed loop around the patient's stomach or esophagus, so that the loop defines a restriction opening (3), and an adjustment means (12) for adjusting the restriction member in said loop to change the size of said restriction opening. A wireless remote control means is provided for non-invasively controlling the adjustment means (12) to adjust the restriction member (2), to thereby obtain a desired size of said restriction opening.

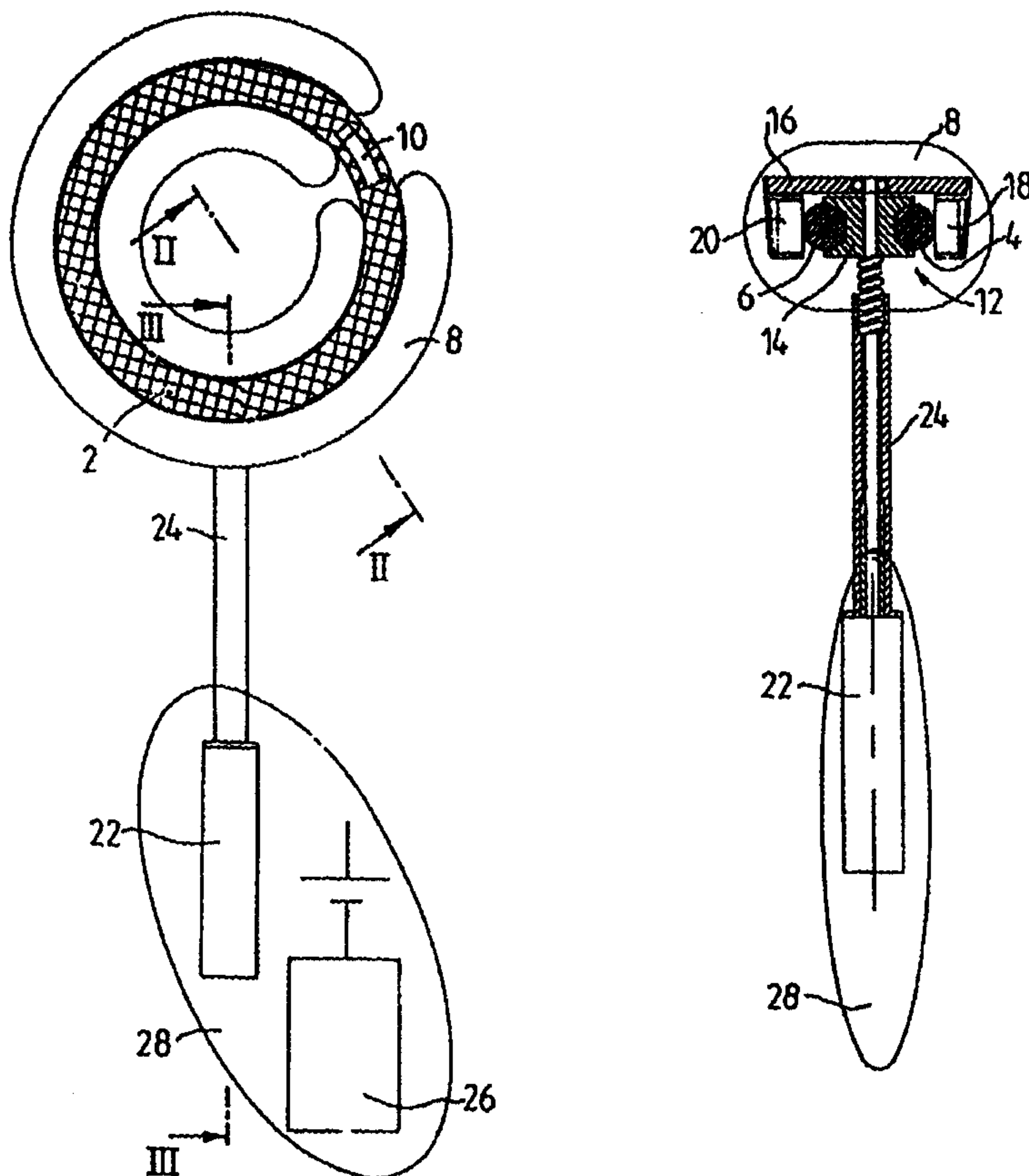

**Food intake restriction device**

The present invention relates to a food intake restriction  
5 device for forming a stoma opening in the stomach or esophagus  
of a patient, the device comprising an elongated restriction  
member, forming means for forming the elongated restriction  
member into at least a substantially closed loop around the  
10 patient's stomach or esophagus, said loop defining a  
restriction opening, and an adjustment means for adjusting the  
restriction member in said loop to change the size of said  
restriction opening. The term "patient" includes an animal or  
a human being.

Food intake restriction devices in the form of gastric  
15 banding devices, in which a band encircles a portion of a  
patient's stomach to restrict the food intake of the patient,  
have been used in surgery for morbid obesity to form a small  
gastric pouch above the band and a reduced stoma opening in the  
stomach. Although such a band is applied around the stomach to  
20 obtain an optimal stoma opening during surgery, some prior  
gastric banding devices are provided with an adjustment means  
enabling a minor post-operation adjustment of the size of the  
stoma opening. In all such prior art devices such as disclosed  
in U.S. Patent No. 4,592,339, European Patent No. 0611561 and  
25 International Patent Application WO 94/27504, the adjustment  
means typically comprises an inflatable cavity in the band and  
an injection port in fluid connection with the inflatable  
cavity for adding fluid to or withdrawing fluid from the  
latter. In practice, the band is made of silicone rubber which  
30 is a material approved for implantation and the fluid is a  
liquid such as an isotonic salt solution.

It has also been found that the volume of the gastric  
pouch above the band increases in size up to ten times after  
operation. Therefore the pouch volume during surgery needs to  
35 be very small, approximately 7 ml. To enable the patient to

feed the stomach with sufficient nutrition immediately after an operation considering such a small gastric pouch, the stoma initially needs to be relatively large and later needs to be substantially reduced, as the pouch volume increases. To be able to achieve a significant range of adjustment of the band, the cavity in the band has to be relatively large and is defined by a thin flexible wall, normally made of silicone material. Furthermore, the size of the stoma opening has to be gradually reduced during the first year after surgery as the gastric pouch increases in size. As indicated above, the reduction of the stoma opening using the prior art devices is achieved by adding liquid to the cavity of the band via the injection port to expand the band radially inwardly.

A great disadvantage of repeatedly injecting liquid via the injection port is the increased risk of the patient getting an infection in the body area surrounding the injection port. If such an infection occurs the injection port has to be surgically removed from the patient. Moreover, such an infection might be spread along the tube interconnecting the injection port and the band to the stomach, causing even more serious complications. Thus, the stomach might be infected where it is in contact with the band, which might result in the band migrating through the wall of the stomach. Also, it is uncomfortable for the patient when the necessary, often many, post-operation adjustments of the stoma opening are carried out using an injection needle penetrating the skin of the patient into the injection port.

It may happen that the patient swallows pieces of food too large to pass through the restricted stoma opening. If that occurs the patient has to visit a doctor who can remove the food pieces, if the band design so permits, by withdrawing some liquid from the band to enlarge the stoma opening to allow the food pieces to pass the stoma. Then, the doctor has to add liquid to the band in order to regain the restricted stoma opening. Again, these measures require the use of an injection

30533-9

3

needle penetrating the skin of the patient, which is uncomfortable for the patient.

An aspect of the invention is to provide a food intake restriction device for forming a stoma opening in the stomach or esophagus of a patient which permits regular post-operation adjustments that are comfortable for the patient.

Another aspect of the present invention is to provide a food intake restriction device for forming a stoma opening in the stomach or esophagus of a patient which is easy to adjust and does not require the use of an injection needle for accomplishing post-operation adjustments of the stoma opening.

The invention relates to food intake restriction device of the kind stated initially, which is characterised by a wireless remote control means for non-invasively controlling the adjustment means to adjust the restriction member, to thereby obtain a desired size of said restriction opening. Thus, the new device does not require use of an injection needle for later adjustments of said restriction opening, thereby eliminating the infection risk discussed above in connection with prior art implantable devices. Of course, an injection port may be provided for enabling, normally a single, once-and-for-all, calibration of the amount of fluid in the adjustment means if it utilizes pneumatic or hydraulic components. Furthermore, the use of the wireless remote control of the new device for controlling the adjustments means is comfortable for the patient.

The remote control means may advantageously be capable of obtaining information on the size of the restriction opening and to command the adjustment means to adjust the restriction member in response to obtained information.

In accordance with a broad aspect of the invention, the remote control means comprises means for wireless transfer of energy from outside the patient's body to energy consuming implantable components of the device. An implantable motor may suitably be provided for operating the adjustment means and said

means for wireless transfer of energy may be adapted to directly power the motor with transferred energy. The energy transferred by said means for transfer of energy may comprise wave signals, an electric field or a magnetic field.

5 Preferably, the wireless remote control means comprises separate signal transmitting means and implantable signal receiving means. The signal receiving means comprises a control unit adapted to control the adjustment means in response to signals from the signal transmitting means. For example, the  
10 signal transmitting and signal receiving means may be adapted to transmit and receive signals in the form of digital pulses, which may comprise a magnetic or electric field. Alternatively, which is preferred, the signal transmitting and signal receiving means may be adapted to transmit and receive wave signals, which  
15 may comprise electromagnetic waves, sound waves or carrier waves for remote control signals.

The food intake restriction device further comprises an implantable energizer unit for providing energy to energy consuming components of the device to be implanted in the  
20 patient, such as electronic circuits and/or a motor for operating the adjustment means. The control unit may be adapted to power such an implanted motor with energy provided by the energizer unit in response to signals received from the signal transmitting means. Any known or conventional signal  
25 transmitting or receiving device that is suitable for use with a human or mammal patient may be provided as the signal transmitting or receiving means. The signals may comprise electromagnetic waves, such as infrared light, visible light, laser light, micro waves, or sound waves, such as ultrasonic  
30 waves or infrasonic waves, or any other type of wave signals. The signals may also comprise electric or magnetic fields, or pulses. All of the above-mentioned signals may comprise digital signals.

The motor may be any type of motor, such as a pneumatic,  
35 hydraulic or electric motor and the energizer unit may be

adapted to power the motor with pressurized gas or liquid, or electrical energy, depending on the type of motor. Where the motor is an electric motor, it may power pneumatic or hydraulic equipment.

5 In accordance with a first particular embodiment of the invention, the energizer unit comprises a power supply and the control unit is adapted to power the motor with energy from the power supply. Preferably, the power supply is an electric power supply, such as a battery, and the motor is an electric motor.  
10 In this case, the battery also continuously powers the circuitry of the signal receiving means between the adjustment operations, in order to keep the signal receiving means prepared for receiving signals transmitted from the signal transmitting means.

15 In accordance with a second, preferred, particular embodiment of the invention, the energizer unit is adapted to transfer energy from the signals, as they are transmitted to the signal receiving means, into electric energy for powering the implanted electronic components. For example, the energizer  
20 unit may be adapted to transfer the energy from the signals into direct or alternating current.

In case there is an implanted electric motor for operating the adjustment means the energizer unit may also power the motor with the transferred energy. Advantageously, the control unit  
25 is adapted to directly power the electric motor with electric energy, as the energizer unit transfers the signal energy into the electric energy. This embodiment is particularly simple and does not require any recurrent invasive measures for exchanging empty power supplies, such as batteries, that is required in the  
30 first embodiment described above.

To expand the field of application of the second preferred embodiment to adjustment means of the type that requires more, but still relatively low, power for its operation, the energizer unit may comprise a rechargeable electric power supply for  
35 storing the electric energy obtained and the control unit be

adapted to power the electric motor with energy from the rechargeable electric power supply in response to signals received from the signal transmitting means. In an initial charging step the rechargeable power supply can be charged over  
5 a relatively long time (e.g. a few seconds up to a half hour) without powering the electric motor. In a following operating step, when the power supply has been charged with sufficient energy, the control unit powers the electric motor with energy from the charged power supply to operate the adjustment means,  
10 so that a desired change of the patient's stoma opening is achieved. If the capacity of the power supply is insignificant to achieve the necessary adjustment in one single operating step, the above steps may conveniently be repeated until the desired adjustment is achieved.

15 The electric power supply suitably comprises an inexpensive simple capacitor. In this case, the electric motor may be a stepping motor.

In connection with the second preferred embodiment the signal transmitting means may be adapted to transmit  
20 electromagnetic wave signals and the energizer unit be adapted to draw radiant energy from the electromagnetic wave signals, as they are transmitted to the signal receiving means, and transfer the radiant energy into electric energy.

In accordance with a third particular embodiment of the  
25 invention, the energizer unit comprises a battery, an electrically operable switch adapted to connect the battery to the signal receiving means in an "on" mode when the switch is powered and to keep the battery disconnected from the signal receiving means in a "standby" mode when the switch is  
30 unpowered, and a rechargeable electric power supply for powering the switch. The control unit is adapted to power the electric motor with energy from the battery in response to signals received from the signal transmitting means, when the switch is in its "on" mode. Advantageously, the energizer unit may be  
35 adapted to transfer wave energy from the signals, as they are

transmitted to the signal receiving means, into a current for charging the rechargeable electric power supply, which suitably is a capacitor. Energy from the power supply is then used to change the switch from "off" (standby mode) to "on". This  
5 embodiment is suited for adjustment means of the type that require relatively high power for their operation and has the advantage that the electronic circuitry of the signal receiving means does not have to be powered by the battery between adjustment operations, as is the case in the above described  
10 first embodiment of the invention. As a result, the life-time of the battery can be significantly prolonged.

In the above-described second and third embodiments of the invention, the signal transmitting means may be adapted to transmit electromagnetic wave signals and the energizer unit be  
15 adapted to draw radiant energy from the electromagnetic wave signals, as they are transmitted to the signal receiving means, and to transfer the radiant energy into said current. The energizer unit suitably comprises a coil of the signal receiving means for inducing an alternating current as electromagnetic  
20 wave signals are transmitted through the coil and a rectifier for rectifying the alternating current. The rectified current is used for charging the rechargeable power source.

Alternatively, the signal transmitting and receiving means may solely be used for control signals and further signal  
25 transmitting and receiving means be provided for transferring signal energy to implanted components. By such a double system of signal transmitting and receiving means the advantage is obtained that the two systems can be designed optimally for their respective purposes, namely to transmit control signals  
30 and to transfer energy from signals.

Although the above-described embodiments of the invention may very well be implemented in connection with the prior types of food intake restriction devices discussed above, in which the adjustment means comprises an inflatable cavity of a restriction  
35 member, it is preferred to use an elongated restriction member

30533-9

8

which is non-inflatable, in order to avoid the risk of fluid leaking from the cavity. Furthermore, it is preferred to use an adjustment means which is designed to mechanically adjust the non-inflatable restriction member.

5           According to another embodiment, there is provided a food intake restriction device for forming a stoma opening in the stomach or esophagus of a patient, the device comprising: an elongated restriction member; forming means for forming the elongated restriction member into at least a  
10 substantially closed loop around the patient's stomach or esophagus, said loop defining a restriction opening; an implantable adjustment means for adjusting the restriction member in said loop to change the size of said restriction opening; a wireless remote control means for non-invasively  
15 controlling the adjustment means to adjust the restriction member, to thereby obtain a desired size of said restriction opening, comprising separate signal transmitting means and implantable signal receiving means, wherein the signal receiving means comprises a control unit for controlling the  
20 adjustment means in response to signals from the signal transmitting means; and an implantable energizer unit for providing energy to energy consuming components of the device to be implanted in the patient, wherein the energizer unit is for transferring wave energy from the signals, as  
25 they are transmitted to the signal receiving means, into electric energy.

          According to a further embodiment, there is provided a food intake restriction device for forming a stoma opening in the stomach or esophagus of a patient, the  
30 device comprising: an elongated restriction member; forming means for forming the elongated restriction member into at least a substantially closed loop around the patient's

30533-9

8a

stomach or esophagus, said loop defining a restriction opening; an implantable adjustment means for adjusting the restriction member in said loop to change the size of said restriction opening; and a wireless remote control means for non-invasively controlling the adjustment means to adjust the restriction member, to thereby obtain a desired size of said restriction opening, wherein the elongated restriction member is non-inflatable.

The invention is described in more detail in the following by way of example with reference to the accompanying drawings, in which

Figure 1 is a schematic cross-sectional view of a part of the food intake restriction device in accordance with the present invention;

Figures 2 and 3 are cross-sectional views taken along the lines II-II and III-III, respectively, of Fig. 1;

Figure 4 is a block diagram illustrating remote control components of the device of the invention;

Figure 5 is a schematic view of exemplary circuitry used for the components of the block diagram of Fig. 4.

Referring to the drawing figures, like reference numerals designate identical or corresponding elements throughout the several figures.

Figs. 1-3 show an example of a part of the food intake restriction device of the invention, comprising a circular resilient non-inflatable restriction member 2 with two

30533-9

8b

overlapping end portions 4,6. The restriction member 2 defines a substantially circular restriction opening 3 and is enclosed in an elastic soft hose 8 except at a releasable and lockable joint 10 of the restriction member 2, which when released enables application of the restriction member 2 with its hose 8 around the esophagus or stomach of a patient in a surgical procedure. All of the in body components are desirably of bio-compatible material or covered with bio-compatible material.

An adjustment means 12 mechanically adjusts the longitudinal extension of the restriction member 2 to change the size of said restriction opening. The adjustment means may comprise any known or conventional mechanical device for this purpose. The illustrated embodiment of the device 12 comprises

a pulley 14 in frictional engagement with the overlapping end portions 4,6. The pulley 14 is journalled on a holder 16 placed in the hose 8 and provided with two counter pressure rollers 18,20 pressing the respective end portions 4, 6 against the pulley 14 to increase the frictional engagement therebetween. An electric motor 22 is connected to the pulley 14 via a long flexible drive shaft 24 and is moulded together with an energizer unit 26 in a body 28 of silicone. The length of the flexible drive shaft 24 is selected so that the body 28 can be placed in a desired position in the abdomen of the patient. All components are of bio-compatible material, or covered with bio-compatible material.

If the patient some time after the operation needs adjustment of the restriction opening 3 of the restriction member 2, the energizer unit 26 is controlled to power the electric motor 22 either to rotate the pulley 14 in one direction to reduce the diameter of the circular restriction member 2 or to rotate the pulley 14 in the opposite direction to increase the diameter of the restriction member 2.

It should be understood that the implantable part of the device described above alternatively may be one of a variety of different adjustable designs. For example, the elongated restriction member may be inflatable by a fluid, which is pumped to and from the restriction member by a pump operated by the motor 22.

Fig. 4 shows the basic parts of an exemplary remote control system of the device of the invention including the electric motor 22. This remote control system is based on the transmission of electromagnetic wave signals, often of high frequencies on the order of 100 kHz - 1 GHz, through the skin of the patient. For the first embodiment of the invention any known or developed remote control system may be utilized; electromagnetic wave signals do not need to be transmitted. In Fig. 4, all parts placed to the left of the skin 30 are located outside the patient's body and are thus not implanted, whereas

WO 00/09048

PCT/SE99/01366

10

all parts placed to the right of the skin 30 are implanted.

An external signal transmitting antenna 32 is to be positioned close to a signal receiving antenna 34 implanted close to the skin 30. As an alternative, the receiving antenna  
5 34 may be placed, for example, inside the abdomen of the patient. The receiving antenna 34 may comprise a coil, approximately 1-100 mm, preferably 25 mm in diameter, wound with a very thin wire and tuned with a capacitor to a specific high frequency. A small coil is chosen if it is to be implanted under  
10 the skin of the patient and a large coil is chosen if it is to be implanted in the abdomen of the patient. The transmitting antenna 32 comprises a coil having about the same size as the coil of the receiving antenna 34 but wound with a thick wire that can handle the larger currents that is necessary. The coil  
15 of the transmitting antenna 32 is tuned to the same specific high frequency as the coil of the receiving antenna 34.

An external control unit 36 preferably comprises a microprocessor, a high frequency electromagnetic wave signal generator and a power amplifier. The microprocessor of the  
20 control unit 36 is adapted to switch the generator on/off and to modulate signals generated by the generator to send digital information via the power amplifier and the antennas 32,34 to an implanted control unit 38. To avoid accidental random high frequency fields triggering control commands, digital signal  
25 codes are used. A conventional keypad 37 placed on the external control unit 36 is connected to the microprocessor thereof. The keypad 37 is used to order the microprocessor to send digital signals to either increase or decrease the size of the restriction opening 3 defined by the loop of the restriction  
30 member 2. The microprocessor starts a command by applying a high frequency signal on the antenna 32. After a short time, when the signal has energized the implanted parts of the control system, commands are sent to increase or decrease the size of said restriction opening of the restriction member 2 in predefined  
35 steps. The commands are preferably sent as digital packets in

SUBSTITUTE SHEET (RULE 26)

WO 00/09048

PCT/SE99/01366

11

the form illustrated below.

Start pattern, 8 bits	Command, 8 bits	Count, 8 bits	Checksum, 8 bits
--------------------------	--------------------	------------------	---------------------

5

The commands are sent continuously during a rather long time period, e.g. about 30 seconds or more. When a new increase or decrease step is desired the Count byte is increased by one to allow the implanted control unit 38 to decode and understand that another step is demanded by the external control unit 36. If any part of the digital packet is erroneous, its content is simply ignored.

Through a line 40, the implanted energizer unit 26 draws energy from the high frequency electromagnetic wave signals received by the receiving antenna 34. The energizer unit 26 stores the energy in a power supply, such as a large capacitor, powers the control unit 38 and powers the electric motor 22 via a line 42.

The control unit 38 comprises a demodulator and a microprocessor. The demodulator demodulates digital signals sent from the external control unit 36. The microprocessor of the control unit 38 receives the digital packet, decodes it and, provided that the power supply of the energizer unit 26 has sufficient energy stored, sends a signal via a signal line 44 to the motor 22 to either increase or decrease the size of the restriction opening 3 of the restriction member 2 depending on the received command code.

Alternatively, the energy stored in the power supply of the energizer unit may only be used for powering a switch, and the energy for powering the motor 22 may be obtained from another implanted power source of relatively high capacity, for example a battery. In this case the switch is adapted to connect said battery to the control unit 38 in an "on" mode when said switch is powered by said power supply and to keep said battery disconnected from the control unit in a "standby" mode when said

switch is unpowered.

With reference to Fig. 5, the remote control system schematically described above will now be described in accordance with a more detailed embodiment. The external control  
5 unit 36 comprises a microprocessor 46, a signal generator 48 and a power amplifier 50 connected thereto. The microprocessor 46 switches the signal generator 48 on/off and to modulate signals generated by the signal generator 48 with digital commands that are sent to implanted components (to the right of skin 30 in  
10 Fig.5) of the implantable device. The power amplifier 50 amplifies the signals and sends them to the external signal transmitting antenna 32. The antenna 32 is connected in parallel with a capacitor 52 to form a resonant circuit tuned to the frequency generated by the signal generator 48.

15 The implanted signal receiving antenna coil 34 forms together with a capacitor 54 a resonant circuit that is tuned to the same frequency as the transmitting antenna 32. The signal receiving antenna coil 34 induces a current from the received high frequency electromagnetic waves and a rectifying diode  
20 60 rectifies the induced current, which charges a storage capacitor 58. A coil 56 connected between the antenna coil 34 and the diode 60 prevents the capacitor 58 and the diode 60 from loading the circuit of the signal receiving antenna 34 at higher frequencies. Thus, the coil 56 makes it possible to charge the  
25 capacitor 58 and to transmit digital information using amplitude modulation.

A capacitor 62 and a resistor 64 connected in parallel and a diode 66 forms a detector used to detect amplitude modulated digital information. A filter circuit is formed by a resistor  
30 68 connected in series with a resistor 70, in turn connected in series with a capacitor 72, in turn connected in series with the resistor 68 via ground, and a capacitor 74, one terminal of which is connected between the resistors 68,70 and the other terminal of which is connected between the diode 66 and the  
35 circuit formed by the capacitor 62 and resistor 64. The filter

circuit is used to filter out undesired low and high frequencies. The detected and filtered signals are fed to an implanted microprocessor 76 that decodes the digital information and controls the motor 22 via an H-bridge 78 comprising  
5 transistors 80,82,84 and 86. The motor 22 can be driven in two opposite directions by the H-bridge 78.

The microprocessor 76 also monitors the amount of stored energy in the storage capacitor 58. Before sending signals to activate the motor 22, the microprocessor 76 checks whether the  
10 energy stored in the storage capacitor 58 is enough. If the stored energy is not enough to perform the requested operation, the microprocessor 76 waits for the received signals to charge the storage capacitor 58 before activating the motor 22.

With the aid of the remote control means it is possible to  
15 programme various sizes of the restriction opening which are to be set by the adjustment means depending on the time of the day. For example, the restriction opening may be relatively large at night, which may be beneficial with respect to the patient's well-being. Means may also be provided for sensing the actual  
20 size of the restriction opening so that the adjustment means can be controlled by the remote control means to adjust the restriction opening in response to such a sensing means.

There are a number of conceivable alternative embodiments of the invention that give the same result as the above-  
25 described embodiments. For example, the microprocessor of the external and implanted, respectively, control units may be replaced by discrete components. The power amplifier of the external control unit may be omitted if the signals generated by the signal generator are strong enough. Therefore, the  
30 invention is to be accorded the broadest interpretation of the appended claims to encompass all equivalent structures and assemblies.

One further advantage with this invention is that there may be a night button on the remote control setting the adjustment  
35 means in a position with a larger stoma diameter during the

WO 00/09048

PCT/SE99/01366

14

night, thus avoiding vomiting or nausea.

30533-9

15

CLAIMS:

1. A food intake restriction device for forming a stoma opening in the stomach or esophagus of a patient, the device comprising:

5 an elongated restriction member;

forming means for forming the elongated restriction member into at least a substantially closed loop around the patient's stomach or esophagus, said loop defining a restriction opening;

10 an implantable adjustment means for adjusting the restriction member in said loop to change the size of said restriction opening;

a wireless remote control means for non-invasively controlling the adjustment means to adjust the restriction member, to thereby obtain a desired size of said restriction opening, comprising separate signal transmitting means and implantable signal receiving means, wherein the signal receiving means comprises a control unit for controlling the adjustment means in response to signals from the signal transmitting means; and

20

an implantable energizer unit for providing energy to energy consuming components of the device to be implanted in the patient,

wherein the energizer unit is for transferring wave energy from the signals, as they are transmitted to the signal receiving means, into electric energy.

25

2. The device according to claim 1, further comprising an implantable motor for operating the adjustment means.

30533-9

16

3. The device according to claim 2, wherein the control unit is for powering the motor with energy provided by the energizer unit in response to signals received from the signal transmitting means.

5 4. The device according to claim 3, wherein the energizer unit comprises a power supply.

5. The device according to claim 4, wherein the power supply is an electric power supply and the motor is an electric motor.

10 6. The device according to claim 5, wherein the electric power supply comprises a battery.

7. The device according to claim 1, wherein the signal transmitting means is for transmitting  
15 electromagnetic wave signals and the energizer unit is for drawing radiant energy from the electromagnetic wave signals as they are transmitted to the signal receiving means and transferring the radiant energy into electric energy.

8. The device according to claim 1, wherein the remote control means comprises further separate signal  
20 transmitting means and further implantable signal receiving means, the energizer unit being for transferring wave energy from the signals, as they are transmitted to the further signal receiving means, into electric energy.

9. The device according to claim 8, wherein the  
25 further signal transmitting means is for transmitting electromagnetic wave signals and the energizer unit is for drawing radiant energy from the electromagnetic wave signals as they are transmitted to the further signal receiving means and transferring the radiant energy into electric  
30 energy.

30533-9

17

10. The device according to any one of claims 6 to 9, further comprising an implantable electric motor for operating the adjustment means, the control unit being for directly powering the electric motor with electric energy, 5 as the energizer unit transfers the wave energy to electric energy.

11. The device according to any one of claims 6 to 9, further comprising an implantable electric motor for operating the adjustment means, the energizer unit 10 comprising a rechargeable electric power supply for storing the electric energy obtained and the control unit being for powering the electric motor with energy from the rechargeable electric power supply in response to signals received from the signal transmitting means.

15 12. The device according to claim 11, wherein the electric power supply comprises a capacitor.

13. The device according to claim 12, wherein the electric motor comprises a stepping motor.

14. The device according to claim 1, wherein the 20 energizer unit comprises a battery, an electrically operable switch for connecting the battery to the signal receiving means in an "on" mode when the switch is powered and for keeping the battery disconnected from the signal receiving means in a "standby" mode when the switch is unpowered, and 25 a rechargeable electric power supply for powering the switch.

15. The device according to claim 14, further comprising an implantable electric motor for operating the adjustment means, the control unit being for powering the 30 electric motor with energy from the battery in response to

30533-9

18

signals received from the signal transmitting means, when the switch is in its "on" mode.

16. The device according to claim 15, wherein the energizer unit is for transferring wave energy from the signals, as they are transmitted to the signal receiving means, into a current for charging the rechargeable electric power supply.

17. The device according to claim 16, wherein the signal transmitting means is for transmitting electromagnetic wave signals and the energizer unit is for drawing radiant energy from the electromagnetic wave signals as they are transmitted to the signal receiving means and transferring the radiant energy into a current.

18. The device according to claim 15, wherein the remote control means comprises further separate signal transmitting means and further implantable signal receiving means, the energizer unit being for transferring wave energy from the signals, as they are transmitted to the further signal receiving means, into a current for charging the rechargeable electric power supply.

19. The device according to claim 18, wherein the further signal transmitting means is for transmitting electromagnetic wave signals and the energizer unit is for drawing radiant energy from the electromagnetic signals as they are transmitted to the further signal receiving means and transferring the radiant energy into a current.

20. The device according to any one of claims 16 to 19, wherein the rechargeable electric power supply comprises a capacitor.

30533-9

19

21. The device according to claim 1, wherein the elongated restriction member is non-inflatable.

22. The device according to claim 21, wherein the adjustment means is for mechanically adjusting the  
5 non-inflatable restriction member.

23. The device according to claim 1, wherein the remote control means comprises means for wireless transfer of energy from outside the patient's body to energy consuming implantable components of the device.

10 24. The device according to claim 23, further comprising an implantable motor for operating the adjustment means, said means for wireless transfer of energy being for directly powering the motor with transferred energy.

15 25. The device according to claim 24, wherein the energy transferred by said means for transfer of energy comprises wave signals.

26. The device according to claim 24, wherein the energy transferred by said means for transfer of energy comprises an electric field or a magnetic field.

20 27. The device according to claim 1, wherein the signal transmitting and signal receiving means are for transmitting and receiving signals in the form of digital pulses.

25 28. The device according to claim 27, wherein the digital pulses comprise a magnetic field or an electric field.

29. The device according to any one of claims 1 to 6, 8, 14 to 16 and 18, wherein the signal transmitting

30533-9

20

and signal receiving means are for transmitting and receiving wave signals.

30. The device according to claim 29, wherein the wave signals comprise electromagnetic waves, sound waves or  
5 carrier waves for remote control signals.

31. The device according to any one of claims 1, 7 to 13, 16 to 20, wherein the energizer unit is for transferring the energy from the signals into direct or alternating current.

10 32. The device according to claim 1, wherein the remote control means is capable of obtaining information on the size of the restriction opening and commanding the adjustment means to adjust the restriction member in response to obtained information.

15 33. A food intake restriction device for forming a stoma opening in the stomach or esophagus of a patient, the device comprising:

an elongated restriction member;

forming means for forming the elongated  
20 restriction member into at least a substantially closed loop around the patient's stomach or esophagus, said loop defining a restriction opening;

an implantable adjustment means for adjusting the restriction member in said loop to change the size of said  
25 restriction opening; and

a wireless remote control means for non-invasively controlling the adjustment means to adjust the restriction member, to thereby obtain a desired size of said restriction opening,

30533-9

21

wherein the elongated restriction member is non-inflatable.

34. The device according to claim 33, wherein the remote control means comprises separate signal transmitting  
5 means and implantable signal receiving means.

35. The device according to claim 34, wherein the signal receiving means comprises a control unit adapted to control the adjustment means in response to signals from the signal transmitting means.

10 36. The device according to claim 35, further comprising an implantable energizer unit for providing energy to energy consuming components of the device to be implanted in the patient.

37. The device according to claim 36, further  
15 comprising an implantable motor for operating the adjustment means.

38. The device according to claim 37, wherein the control unit is adapted to power the motor with energy provided by the energizer unit in response to signals  
20 received from the signal transmitting means.

39. The device according to claim 38, wherein the energizer unit comprises a power supply.

40. The device according to claim 39, wherein the power supply is an electric power supply and the motor is an  
25 electric motor.

41. The device according to claim 40, wherein the electric power supply comprises a battery.

42. The device according to claim 36, wherein the energizer unit is adapted to transfer wave energy from the

30533-9

22

signals, as they are transmitted to the signal receiving means, into electric energy.

43. The device according to claim 42, wherein the signal transmitting means is adapted to transmit  
5 electromagnetic wave signals and the energizer unit is adapted to draw radiant energy from the electromagnetic wave signals as they are transmitted to the signal receiving means and transfer the radiant energy into electric energy.

44. The device according to claim 36, wherein the  
10 remote control means comprises further separate signal transmitting means and further implantable signal receiving means, the energizer unit being adapted to transfer wave energy from the signals, as they are transmitted to the further signal receiving means, into electric energy.

15 45. The device according to claim 44, wherein the further signal transmitting means is adapted to transmit electromagnetic wave signals and the energizer unit is adapted to draw radiant energy from the electromagnetic wave signals as they are transmitted to the further signal  
20 receiving means and transfer the radiant energy into electric energy.

46. The device according to any one of claims 42 to 45, further comprising an implantable electric motor for operating the adjustment means, the control unit being  
25 adapted to directly power the electric motor with electric energy, as the energizer unit transfers the wave energy to electric energy.

47. The device according to any one of claims 42 to 45, further comprising an implantable electric motor for  
30 operating the adjustment means, the energizer unit comprising a rechargeable electric power supply for storing

30533-9

23

the electric energy obtained and the control unit being adapted to power the electric motor with energy from the rechargeable electric power supply in response to signals received from the signal transmitting means.

5 48. The device according to claim 47, wherein the electric power supply comprises a capacitor.

49. The device according to claim 48, wherein the electric motor comprises a stepping motor.

10 50. The device according to claim 36, wherein the energizer unit comprises a battery, an electrically operable switch adapted to connect the battery to the signal receiving means in an "on" mode when the switch is powered and to keep the battery disconnected from the signal receiving means in a "standby" mode when the switch is  
15 unpowered, and a rechargeable electric power supply for powering the switch.

51. The device according to claim 50, further comprising an implantable electric motor for operating the adjustment means, the control unit being adapted to power  
20 the electric motor with energy from the battery in response to signals received from the signal transmitting means, when the switch is in its "on" mode.

52. The device according to claim 51, wherein the energizer unit is adapted to transfer wave energy from the  
25 signals, as they are transmitted to the signal receiving means, into a current for charging the rechargeable electric power supply.

53. The device according to claim 52, wherein the signal transmitting means is adapted to transmit  
30 electromagnetic wave signals and the energizer unit is

30533-9

24

adapted to draw radiant energy from the electromagnetic wave signals as they are transmitted to the signal receiving means and transfer the radiant energy into a current.

54. The device according to claim 51, wherein the  
5 remote control means comprises further separate signal transmitting means and further implantable signal receiving means, the energizer unit being adapted to transfer wave energy from the signals, as they are transmitted to the further signal receiving means, into a current for charging  
10 the rechargeable electric power supply.

55. The device according to claim 54, wherein the further signal transmitting means is adapted to transmit electromagnetic wave signals and the energizer unit is adapted to draw radiant energy from the electromagnetic  
15 signals as they are transmitted to the further signal receiving means and transfer the radiant energy into a current.

56. The device according to any one of claims 52 to 55, wherein the rechargeable electric power supply.  
20 comprises a capacitor.

57. The device according to claim 33, wherein the adjustment means is designed to mechanically adjust the non-inflatable restriction member.

58. The device according to claim 33, wherein the  
25 remote control means comprises means for wireless transfer of energy from outside the patient's body to energy consuming implantable components of the device.

59. The device according to claim 58, further comprising an implantable motor for operating the adjustment

30533-9

25

means, said means for wireless transfer of energy being adapted to directly power the motor with transferred energy.

60. The device according to claim 59, wherein the energy transferred by said means for transfer of energy  
5 comprises wave signals.

61. The device according to claim 59, wherein the energy transferred by said means for transfer of energy comprises an electric field or a magnetic field.

62. The device according to claim 34, wherein the  
10 signal transmitting and signal receiving means are adapted to transmit and receive signals in the form of digital pulses.

63. The device according to claim 62, wherein the digital pulses comprise a magnetic field or an electric  
15 field.

64. The device according to any one of claims 34 to 42, 44, 50 to 52 and 54 wherein the signal transmitting and signal receiving means are adapted to transmit and receive wave signals.

20 65. The device according to claim 64, wherein the wave signals comprise electromagnetic waves, sound waves or carrier waves for remote control signals.

66. The device according to any one of claims 42 to 49, 52 to 56, wherein the energizer unit is adapted to  
25 transfer the energy from the signals into direct or alternating current.

67. The device according to claim 33, wherein the remote control means is capable of obtaining information on the size of the restriction opening and to command the

30533-9

26

adjustment means to adjust the restriction member in response to obtained information.

FETHERSTONHAUGH & CO.

OTTAWA, CANADA

PATENT AGENTS

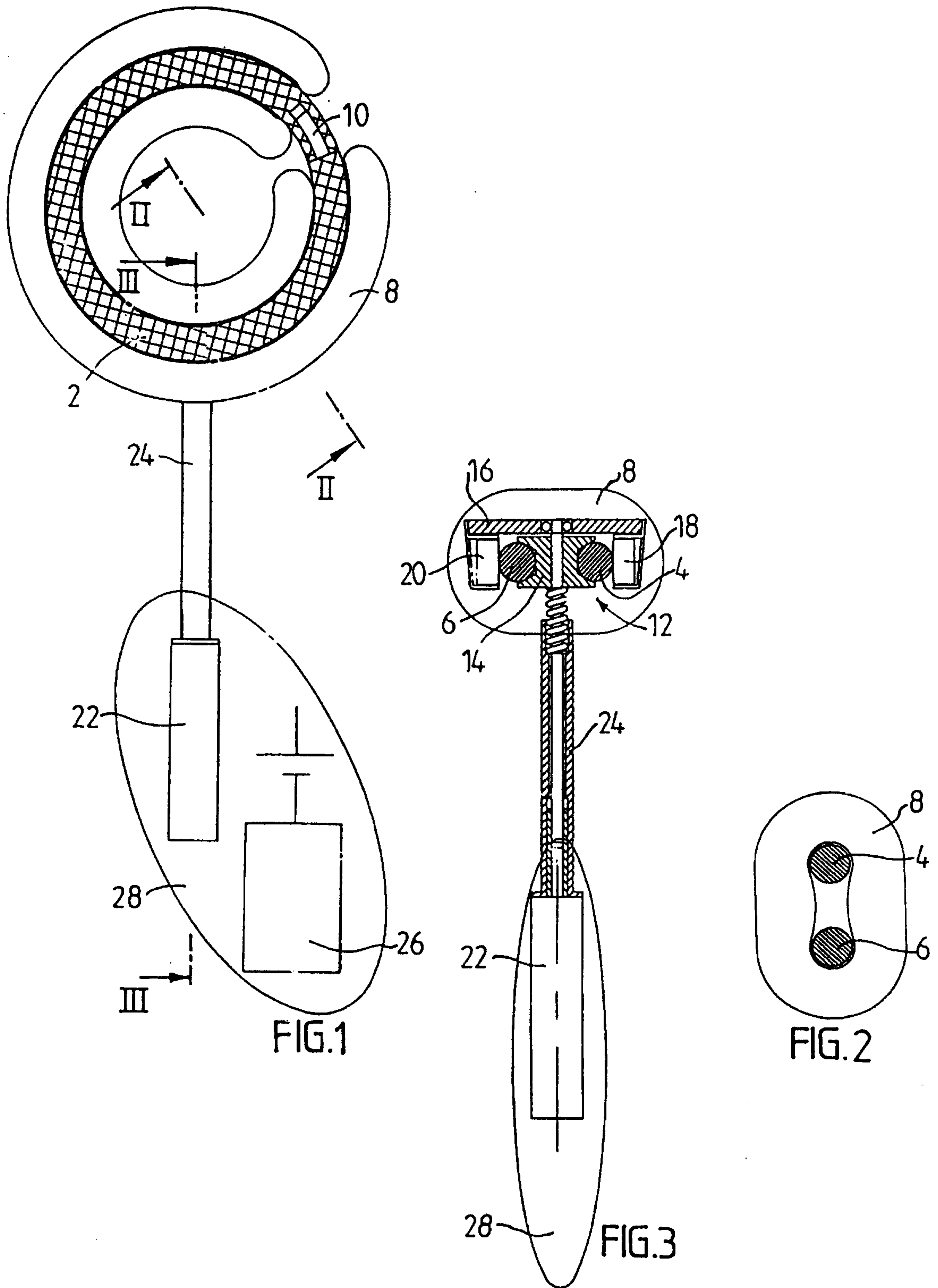

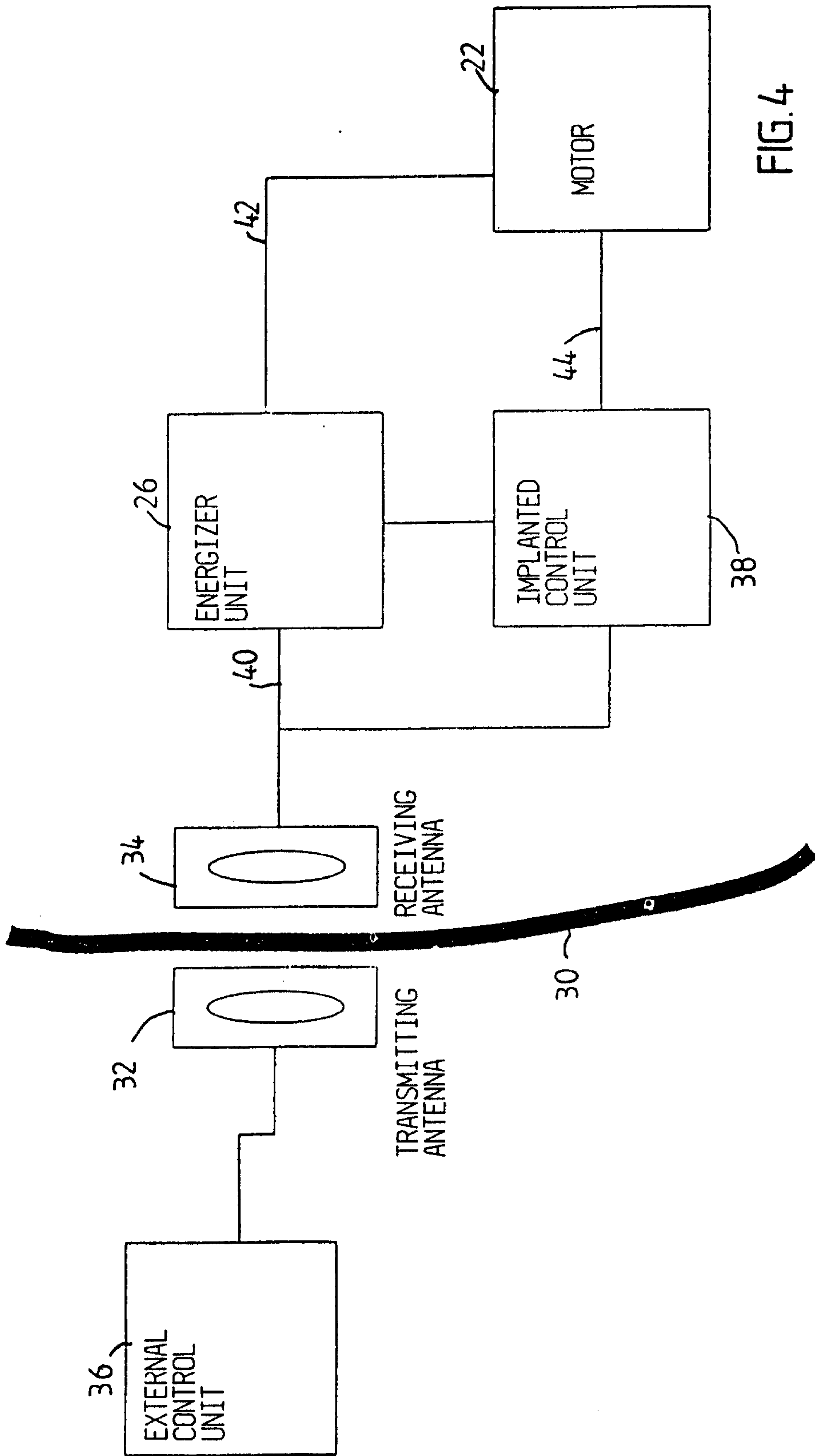

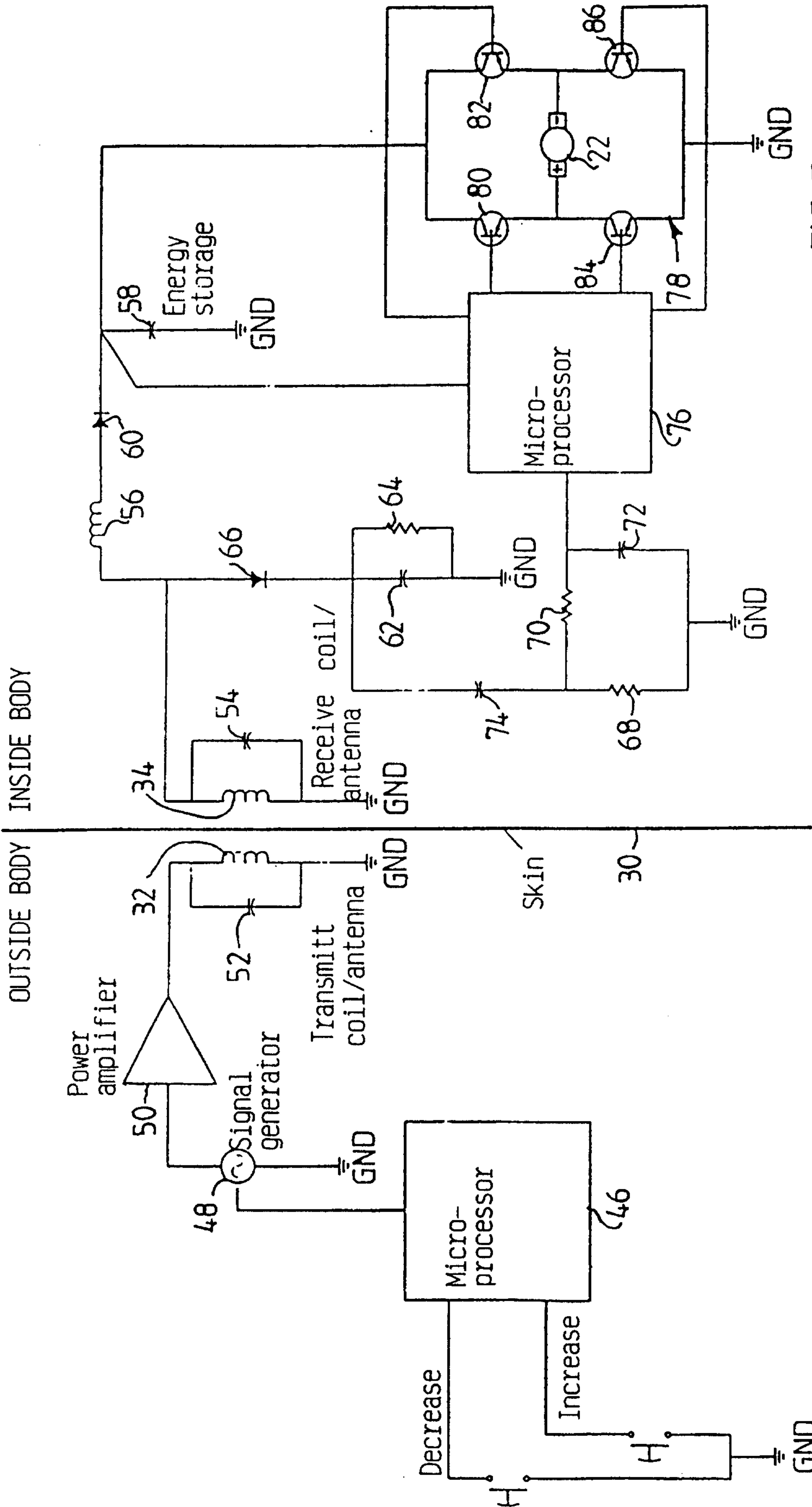

FIG. 5

