



US00D344684S

United States Patent [19]

[11] Patent Number: Des. 344,684

Metz et al.

[45] Date of Patent: ** Mar. 1, 1994

[54] MULTI-PURPOSE USER INTERFACE PANEL

[75] Inventors: **Stephen V. Metz**, St. Paul; **Guy M. Shoultz**, Delano, both of Minn.

[73] Assignee: **Honeywell Inc.**, Minneapolis, Minn.

[**] Term: **14 Years**

[21] Appl. No.: **931,224**

[22] Filed: **Aug. 17, 1992**

[52] U.S. Cl. **D10/103; D13/177; D10/60**

[58] Field of Search **364/500; 395/155-160; D10/49, 52, 60, 103; D13/177**

[56] References Cited

U.S. PATENT DOCUMENTS

- D. 288,921 3/1987 Peck D13/177
- D. 310,177 8/1990 Bensoussan et al. D10/50
- 5,182,796 1/1993 Shibayama et al. 395/155 X
- 5,230,063 7/1993 Hoeber et al. 395/155 X

Primary Examiner—Nelson C. Holtje
Assistant Examiner—Antoine D. Davis
Attorney, Agent, or Firm—Edmund P. Anderson;
Michael B. Atlass

[57] CLAIM

The ornamental design for a multi-purpose user interface panel, as shown and described.

DESCRIPTION

FIG. 1 is a view of the subject invention in perspective; FIG. 2 is a left side elevation of the device of FIG. 1 as seen from left to right of FIG. 1; FIG. 3 is a right side elevation of the device of FIG. 1 as seen from side opposite that shown in FIG. 2; FIG. 4 is a view of the device of FIG. 1 from the front elevation; FIG. 5 is a view of the device of FIG. 1 in top plan; FIG. 6 is a view of the device of FIG. 1 in bottom plan;

FIG. 7 is a view of the device of FIG. 1 from the rear elevation; FIG. 8 is an embodiment of the device of FIG. 1, having accent bars in the areas shown; FIG. 9 is a left side elevation of the device of FIG. 8 as seen from left to right of FIG. 8; FIG. 10 is a right side elevation of the device of FIG. 8 as seen from side opposite that shown in FIG. 9; FIG. 11 is a view of the device of FIG. 8 from the front elevation; FIG. 12 is a view of the device of FIG. 8 in top plan; FIG. 13 is a view of the device of FIG. 8 in bottom plan; FIG. 14 is a view of the device of FIG. 8 from the rear elevation; FIG. 15 is an embodiment of the device of FIG. 1, having a bezel; FIG. 16 is a left side elevation of the device of FIG. 15 as seen from left to right of FIG. 15; FIG. 17 is a right side elevation of the device of FIG. 15 as seen from side opposite that shown in FIG. 16; FIG. 18 is a view of the device of FIG. 15 from the front elevation; FIG. 19 is a view of the device of FIG. 15 in top plan; FIG. 20 is a view of the device of FIG. 15 in bottom plan; FIG. 21 is a view of the device of FIG. 15 from the rear elevation; FIG. 22 is a view of an embodiment of the device of FIG. 1, having accent bars in the areas shown and a bezel; FIG. 23 is a left side elevation of the device of FIG. 22 as seen from left to right of FIG. 22; FIG. 24 is a right side elevation of the device of FIG. 22 as seen from side opposite that shown in FIG. 23; FIG. 25 is a view of the device of FIG. 22 from the front elevation; FIG. 26 is a view of the device of FIG. 22 in top plan; FIG. 27 is a view of the device of FIG. 22 in bottom plan; and, FIG. 28 is a view of the device of FIG. 22 from the rear elevation.

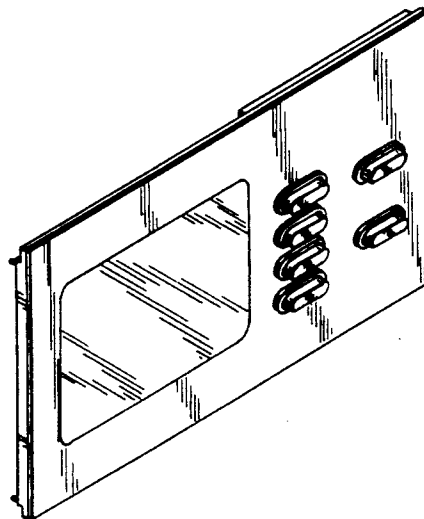

Fig. 1

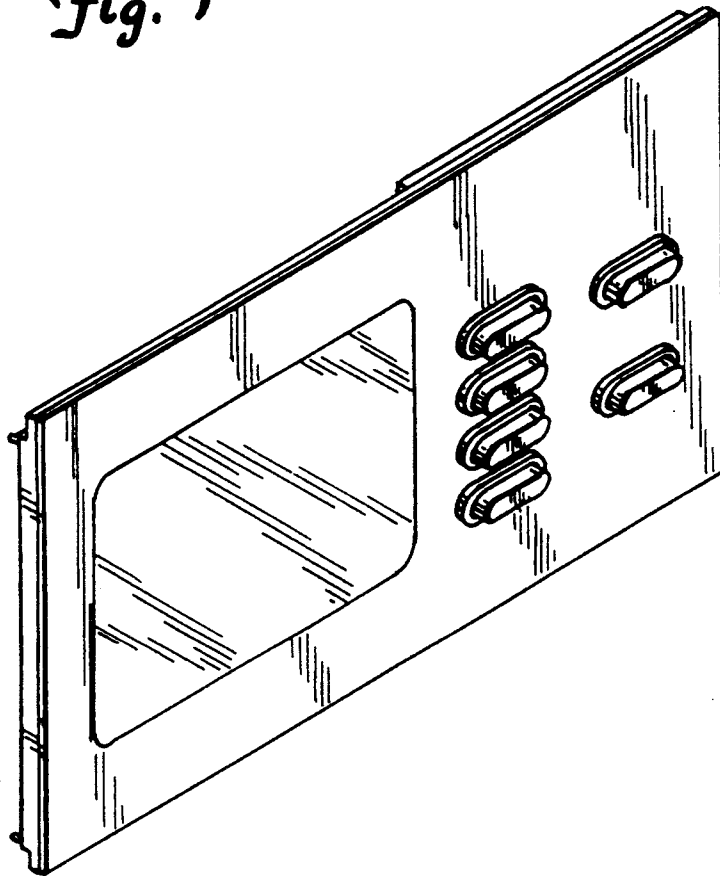

Fig. 3



Fig. 2



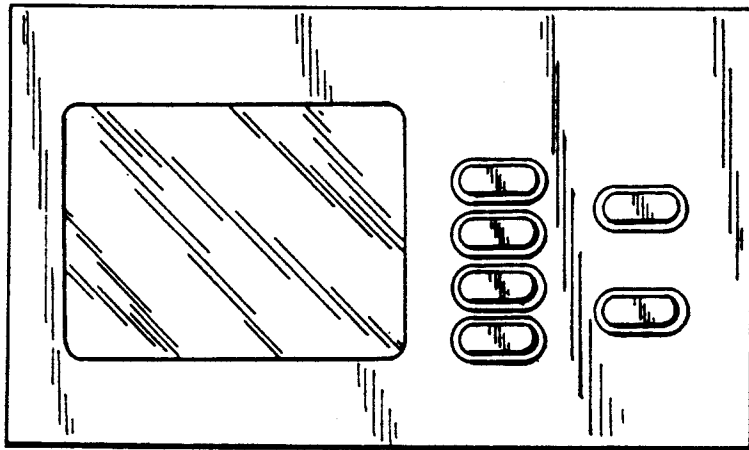

Fig. 4

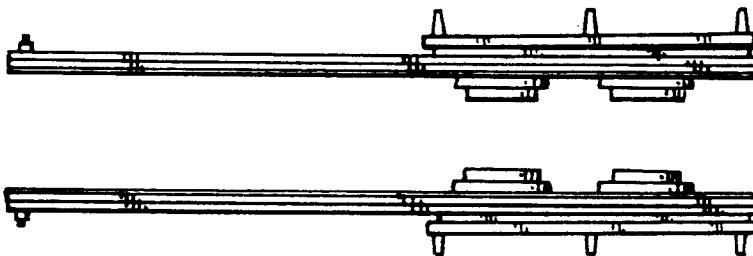

Fig. 5

Fig. 6

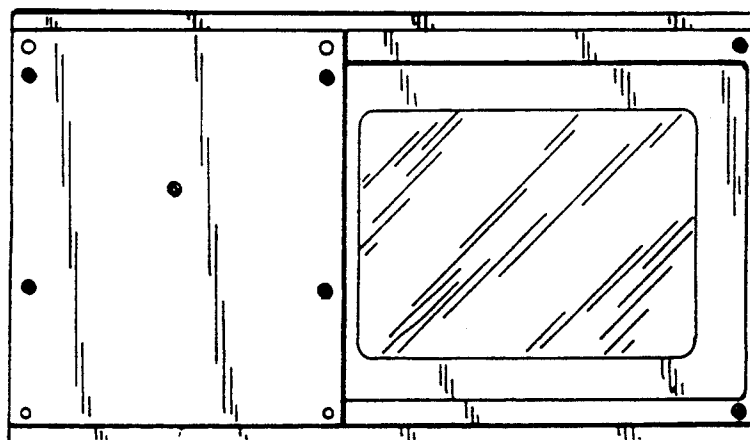

Fig. 7

Fig. 8

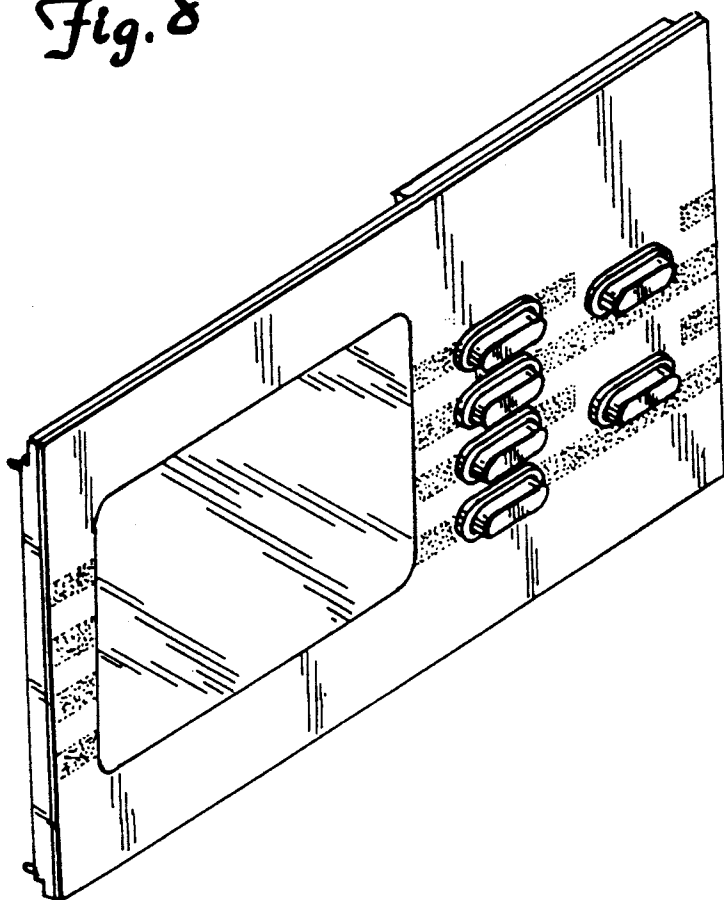

Fig. 10

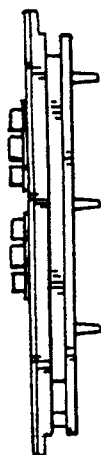

Fig. 9



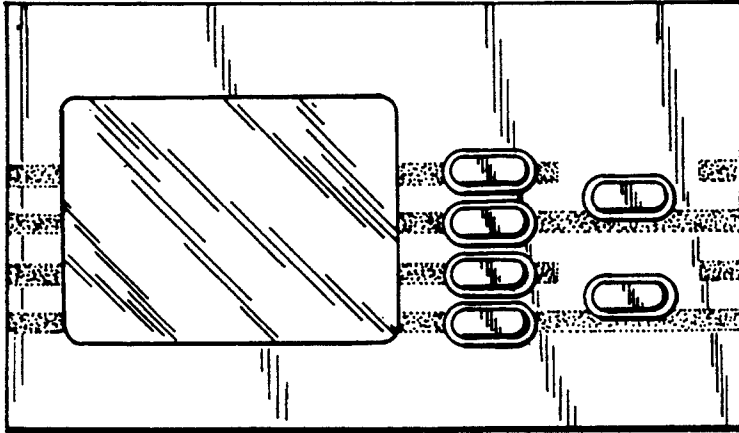

Fig. 11



Fig. 12



Fig. 13

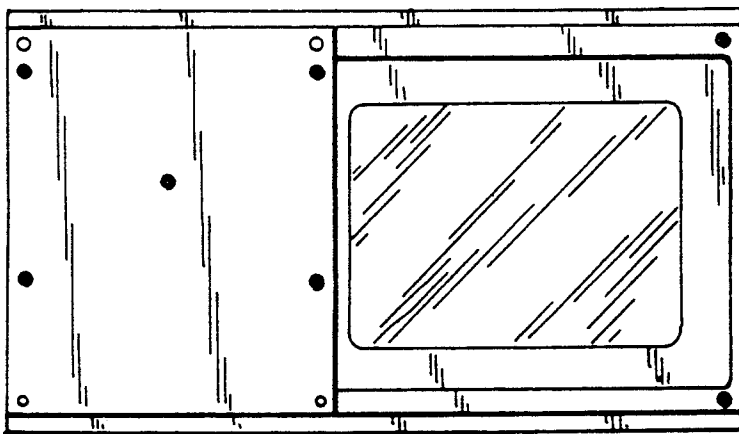

Fig. 14

Fig. 15

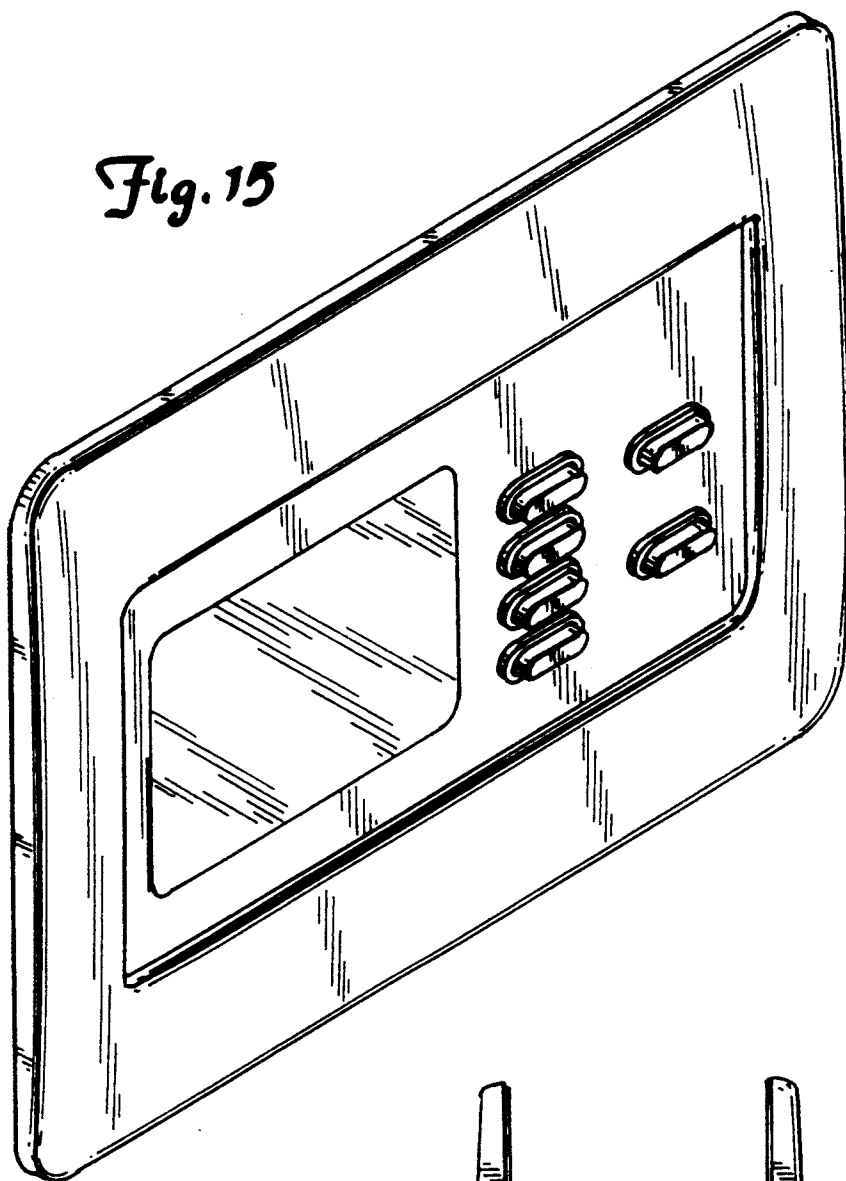

Fig. 17



Fig. 16



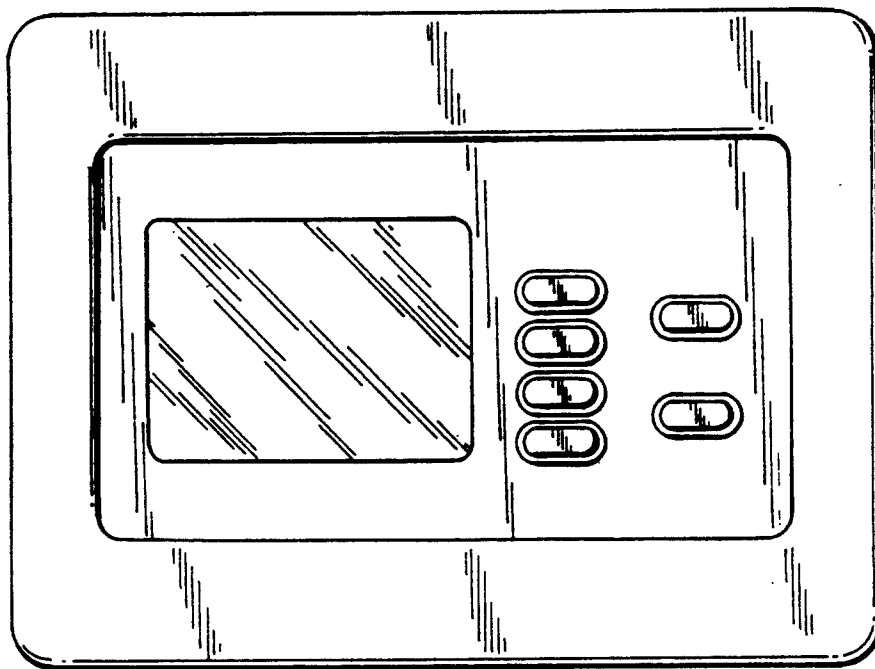

Fig. 18

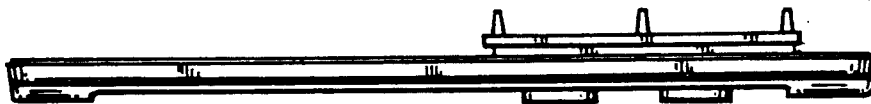

Fig. 19

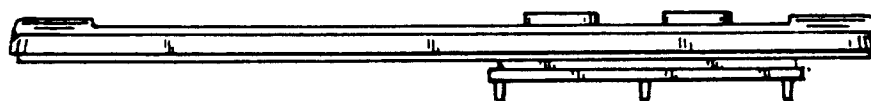

Fig. 20

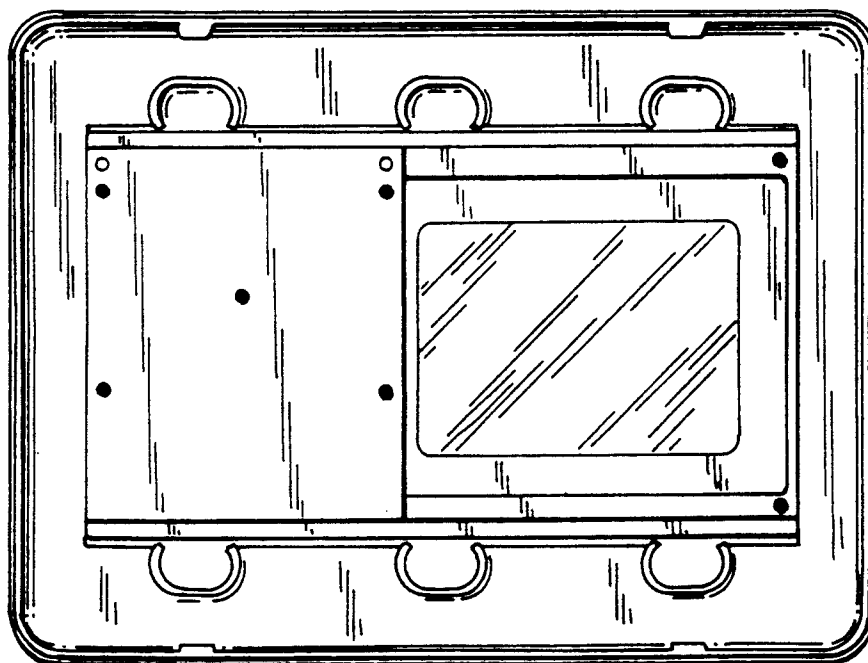

Fig. 21

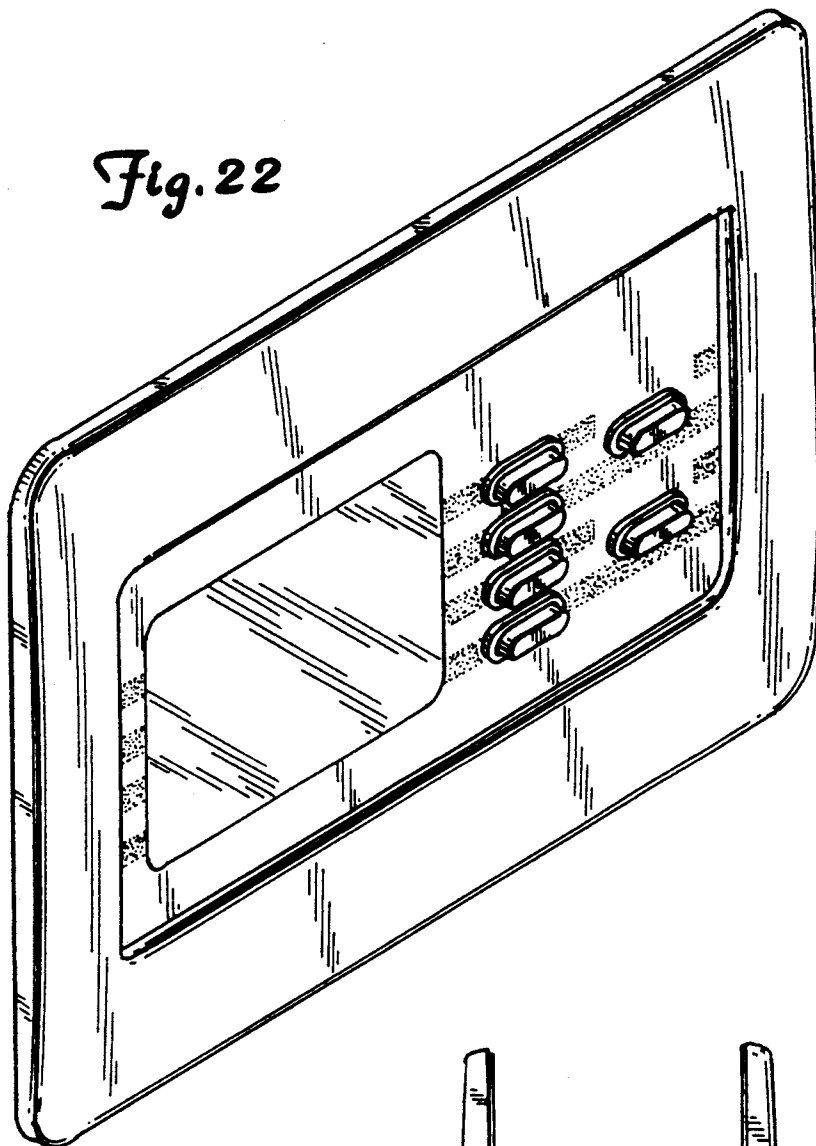

Fig. 24



Fig. 23



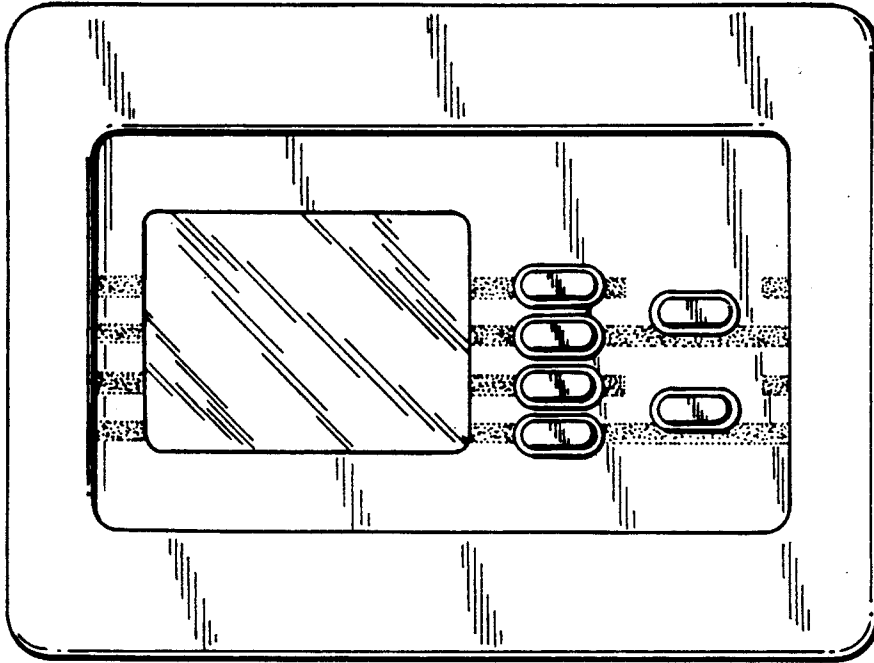

Fig. 25

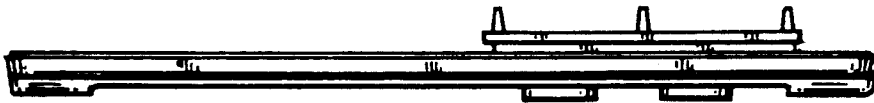

Fig. 26

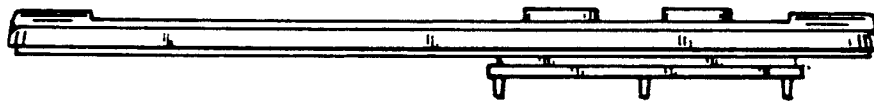

Fig. 27

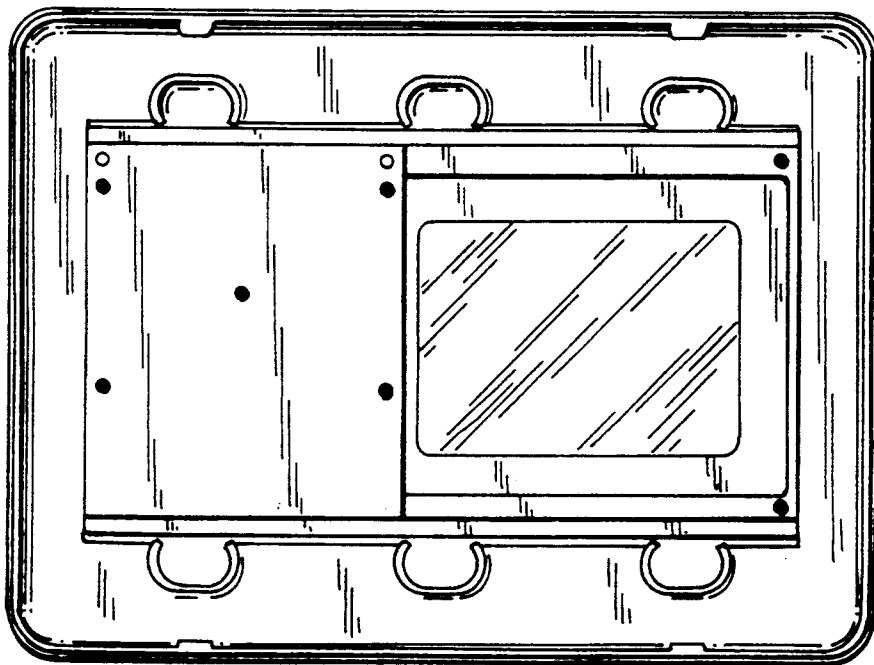

Fig. 28