

No. 613,079.

Patented Oct. 25, 1898.

S. ROSS.  
HEEL FINISHING DEVICE.

(Application filed Apr. 20, 1897.)

(No Model.)

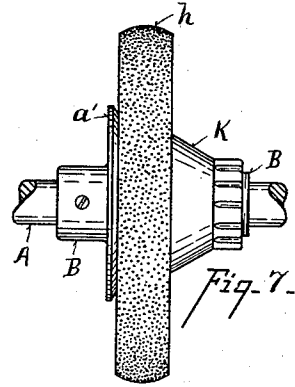
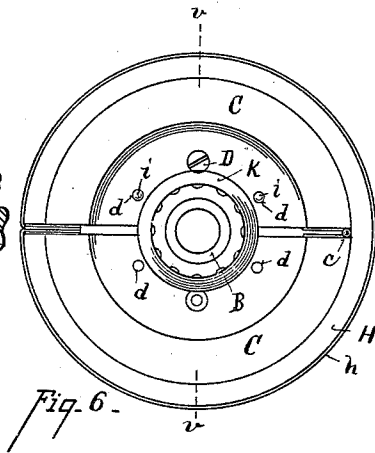
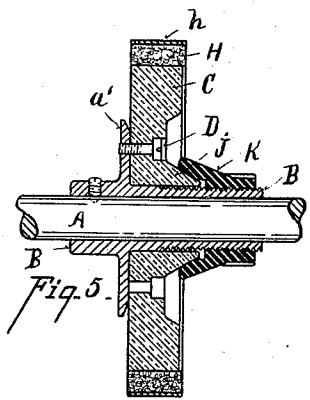
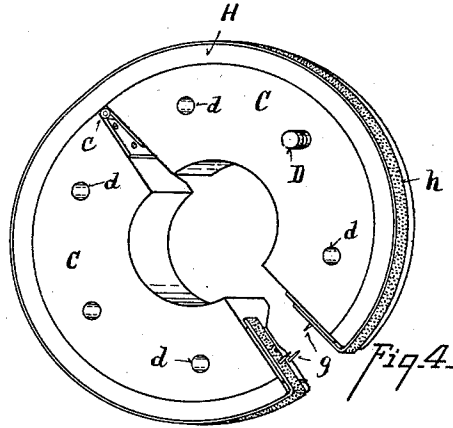
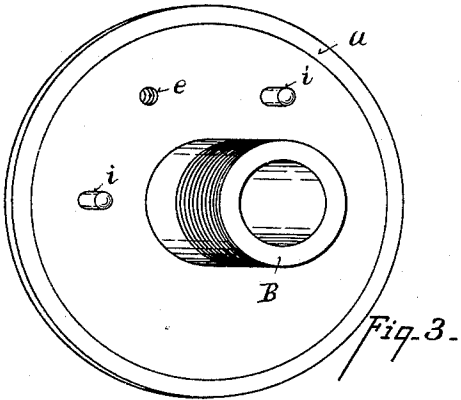
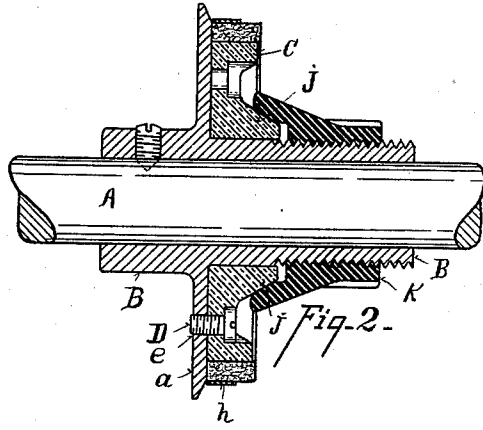
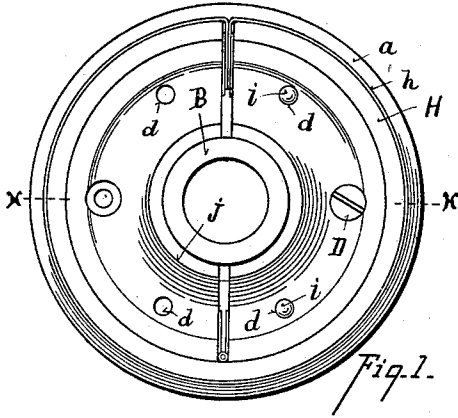

Inventor

Witnesses  
C. W. Miles.  
Glenn B. Haizer.

Simon Ross  
by Woodward  
Attorneys

# UNITED STATES PATENT OFFICE.

SIMON ROSS, OF CINCINNATI, OHIO.

## HEEL-FINISHING DEVICE.

SPECIFICATION forming part of Letters Patent No. 613,079, dated October 25, 1898.

Application filed April 20, 1897. Serial No. 633,039. (No model.)

To all whom it may concern:

Be it known that I, SIMON ROSS, residing at Cincinnati, in the county of Hamilton and State of Ohio, have invented certain new and useful Improvements in Heel-Finishing Devices, of which the following is a specification.

The object of my invention is to provide a reversible and interchangeable disk or form upon the peripheral edge of which cushion material is attached in the usual manner and to the edge of which cushion abrasive material is applied for finishing the edges of boot and shoe heels. Each form to which the abrasive material is applied is adapted to finish only one particular style of heel. There is a great variety of styles of heels, having different dimensions and curves on the edges. By the use of my device a series of interchangeable forms on one hub or holder only is required. It is much easier and cheaper to change the forms as embodied in my invention than it is to remove the entire wheel from the shaft, which is now the common practice. When the entire wheel is removed, it must be mounted on the end of the shaft outside of the bearing; but with my device a split form is used and a series of holders may be used side by side on the same shaft, the split forms being readily detachable from the hubs.

The features of my invention are more fully set forth in the description of the accompanying drawings, making a part of this specification, in which—

Figure 1 is a front elevation of my improvement. Fig. 2 is a section on line *x x*, Fig. 1. Fig. 3 is a perspective view of the hub on which the form is mounted. Fig. 4 is a perspective view of the form in position to be applied to the hub. Fig. 5 is a modification of Fig. 2 on line *v v*, Fig. 6. Fig. 6 is a side elevation of Fig. 5. Fig. 7 is a plan view of Fig. 6.

A represents a shaft; B, a hub or form-holder secured thereon. Said hub is preferably provided with a disk *a*, to which the form C is secured. In Fig. 2 this disk is shown as extended radially slightly beyond the form C. In Fig. 5 it is much smaller in dimension, as indicated by *a'*. It is employed simply as a convenient means for securing the form to the hub. The extended disk

shown in Fig. 2 projects beyond the abrasive material, so that the edge of the disk will serve as a guard, which is desirable in some styles of work. For other classes of work this guard is objectionable.

The form C is composed of two semicircular bases, which are united by a hinge *c*. *H* represents the cushioning material secured to the periphery of said split form. *h* represents the abrasive material. One end of the hub B is provided with screw-threads. The form C engages on the hub B.

*i i* represent pins projecting from the disk A, which enter holes *d* in one or the other of the segments of the form.

*e* represents a screw-threaded hole between the pins *i i*.

D represents a screw passing through the form and engaging with the threads of hole *e*. This is not essential, but is a convenient means for securing the form in place.

The form is firmly secured on the hub by means of the sleeve-nut K engaging the threads of hub B, and the sleeve portion or conical end of said nut engaging over the conical boss *j* of form C draws the two sections of the form together and holds them firmly in position. The pins *i i* and screw D are simply to hold one section in position when the nut K is slackened for the purpose of changing the abrasive material.

The abrasive material is held in place by means of pins *g*, which are inserted inside or meeting edges of the form-sections, the ends of the abrasive material being drawn over these pins.

I have shown both halves of the form provided with holes *d d* for engaging the pins *i i*, as it is desirable in practice to have both right and left hand finishers and to have the movable section open toward the operator.

In Figs. 2 and 5 the edge of the form is shown straight, as indicated by *h h*, and it is adapted to finish heels which are flat or inclined. In Fig. 7 the edge of the form is oval, as at *h'*, and adapted to finish only concave heels. Each particular style of heel requires a particular shaped edge, which necessitates the use of a large variety of forms for the different styles of heels daily made in factories. By means of the hub and detachable forms here shown the operator can readily

change from one style to another by simply removing the split-form sections and replacing them with another form, which is a material saving in cost and time over the older methods.

5 Having described my invention, I claim—

1. In a heel-finishing wheel, the combination with a shaft, of a hub fixedly secured on said shaft and provided with a disk near one  
10 end and an exteriorly-threaded extension at its other end, a split form arranged on the hub and provided on its face opposite the disk with a conical boss, means for detachably fastening either of the sections of the split form  
15 to the disk at will, and a nut screwed on the threaded extension of the hub and provided with an interiorly-threaded sleeve which engages the said conical boss and forces the form against the disk and clamps the unattached  
20 section of the form to the hub, substantially as described.

2. In a heel-finishing wheel, the combination with a shaft, of a hub fixedly secured on said shaft and provided with a disk near one  
25 end and an exteriorly-threaded extension at its other end, a split form arranged on the hub and provided on its face opposite the disk with a conical boss, a screw passed through

said form and engaging a threaded aperture in the disk, pins fixed in the disk and arranged to engage either of a corresponding series of apertures formed in both sections of the split form, and a nut screwed on the threaded extension of the hub and provided with an interiorly-tapered sleeve which en-  
35 gages the said conical boss and forces the form against the disk and contracts it about the hub, substantially as described.

3. In a heel-finishing device, in combination with a shaft, an extended hub secured  
40 to said shaft, and provided with a holding-disk, a conical screw-nut, a split form provided with a boss adapted to be engaged by said nut, said form being detachably supported upon said hub between the holding-  
45 disk and conical nut, and means for attaching one only of the sections of the split form to said disk and hub, substantially as specified.

In testimony whereof I have hereunto set  
50 my hand.

SIMON ROSS.

Witnesses:

W. R. WOOD,  
OLIVER B. KAISER.