



- (51) **International Patent Classification:**
E21B 19/00 (2006.01)
- (21) **International Application Number:**
PCT/EP2011/055765
- (22) **International Filing Date:**
13 April 2011 (13.04.2011)
- (25) **Filing Language:** English
- (26) **Publication Language:** English
- (30) **Priority Data:**
20100532 14 April 2010 (14.04.2010) NO
- (71) **Applicant (for all designated States except US):** AKER
SUBSEA AS [NO/NO]; P.O.Box 94, N-1325 Lysaker
(NO).
- (72) **Inventors; and**
- (75) **Inventors/Applicants (for US only):** BILLINGTON,
Anders [NO/NO]; Linderudgrenda 5, N-1353 Bærum
Verk (NO). SYNNES, Are [NO/NO]; Jenshaugveien 9c,
N-1363 Høvik (NO). SØVIK, Christen [NO/NO];
Blystadringen 6D, N-2014 Blystadlia (NO).
- (74) **Agent:** PROTECTOR IP CONSULTANTS AS; Os-
carsgate 20, N-0352 Oslo (NO).

- (81) **Designated States (unless otherwise indicated, for every kind of national protection available):** AE, AG, AL, AM, AO, AT, AU, AZ, BA, BB, BG, BH, BR, BW, BY, BZ, CA, CH, CL, CN, CO, CR, CU, CZ, DE, DK, DM, DO, DZ, EC, EE, EG, ES, FI, GB, GD, GE, GH, GM, GT, HN, HR, HU, ID, IL, IN, IS, JP, KE, KG, KM, KN, KP, KR, KZ, LA, LC, LK, LR, LS, LT, LU, LY, MA, MD, ME, MG, MK, MN, MW, MX, MY, MZ, NA, NG, NI, NO, NZ, OM, PE, PG, PH, PL, PT, RO, RS, RU, SC, SD, SE, SG, SK, SL, SM, ST, SV, SY, TH, TJ, TM, TN, TR, TT, TZ, UA, UG, US, UZ, VC, VN, ZA, ZM, ZW.
- (84) **Designated States (unless otherwise indicated, for every kind of regional protection available):** ARIPO (BW, GH, GM, KE, LR, LS, MW, MZ, NA, SD, SL, SZ, TZ, UG, ZM, ZW), Eurasian (AM, AZ, BY, KG, KZ, MD, RU, TJ, TM), European (AL, AT, BE, BG, CH, CY, CZ, DE, DK, EE, ES, FI, FR, GB, GR, HR, HU, IE, IS, IT, LT, LU, LV, MC, MK, MT, NL, NO, PL, PT, RO, RS, SE, SI, SK, SM, TR), OAPI (BF, BJ, CF, CG, CI, CM, GA, GN, GQ, GW, ML, MR, NE, SN, TD, TG).

Declarations under Rule 4.17:

- as to applicant's entitlement to apply for and be granted a patent (Rule 4.17(ii))
- of inventorship (Rule 4.17(iv))

[Continued on next page]

(54) **Title:** SUBSEA ORIENTATION AND CONTROL SYSTEM

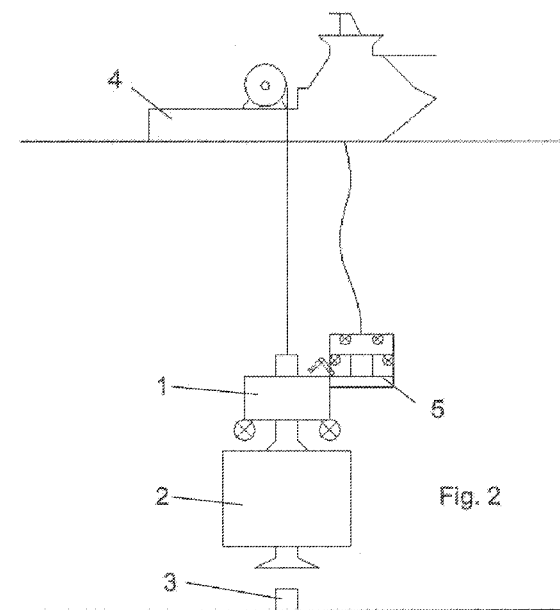

(57) **Abstract:** The invention provides a tool for subsea installation and testing of wellhead modules such as Xmas trees and similar equipment, from a ship using a ship crane, distinctive in that the tool comprises a subsea unit comprising a connector for releasable connection to subsea wellhead modules or equipment, means for positioning and means for testing, and a connector for electric power and electric and/or optical control. Method using the tool.



Published:

- *without international search report and to be republished upon receipt of that report (Rule 48.2(g))*

SUBSEA ORIENTATION AND CONTROL SYSTEM

5 Field of the invention

The present invention relates to subsea wellhead stacks. More specifically, the invention relates to tools and methods for installation of wellhead stacks, such as wellhead XT (Christmas trees) and associated equipment.

10 Background of the invention and prior art

Currently, subsea wellhead stacks are typically installed by using a drilling rig and a string of drillpipe for deployment. A separate umbilical from the rig to the wellhead equipment provides pressurized fluids for testing and commissioning, in addition to electric power and control lines. Typically one or more ROV's are also used in the operation. The time and equipment used is very expensive. In shallow waters, if the drilling rig is on the field and has commenced drilling and then is used to install a few production XT (Christmas trees) and other related equipment, this can be sensible, particularly if the drilling rig still is under contract. However, in deep water, which can be thousands of meters of depth, and with a large number of wellheads, the cost can be tremendous. Sometimes the rig must return for further testing or installation, which adds to the costs. The operation of joining drill pipes to lengths of up to several thousand meters, and large drums with umbilicals, installations for hydraulic power units, hydraulic liquid storage and gas for testing, are all expensive and time consuming. The heavy weight and size require large space, and may require several containers on deck on the rig. Therefore, a demand exists for technology useful for installation and testing of subsea wellhead stacks without using a drilling rig, and technology that make significant cuts in the required equipment and the period of time for such operation.

30

Summary of the invention

The present invention meets the above mentioned demand.

More specifically, the invention provides a tool for subsea installation and testing of wellhead modules such as Xmas trees and similar equipment, from a ship using a ship crane, distinctive in that the tool comprises

5 a subsea unit comprising a connector for releasable connection to subsea wellhead modules or equipment, means for positioning and means for testing, and a connector for electric power and electric and/or optical control.

The tool has no supply of hydraulic liquid or gas via umbilical or other pressure line from the surface, as only electric power and electric and/or optical control
10 signals are transferred between the surface position and the wellhead area. The tool is adapted for being handled by a ship crane, as hanging in a wire or rope connected via lifting lugs, a spreader or similar means. The tool comprises a topsides control means and connection to electrical power and control means, in addition to the subsea unit. The subsea unit is connected to the topsides
15 facilities by an electrical/optical umbilical, optionally via an ROV connected to the subsea unit, i.e. the umbilical of a work-ROV system can be used for power and control. Accordingly, there is no riser or hose for pressurized fluid from the ship down to the tool, neither for installation, commissioning nor testing, which provides a huge advantage of the invention over conventional technology,
20 particularly where the depth is large and the wellhead stacks are many.

The tool is useful for installation and testing of all functions, and communication to all sensors, for subsea equipment, particularly wellhead production X-mas trees, -modules, pumps compressors and units of different types, particularly
25 equipment that is too heavy and/or large to be installed and tested using conventional ROV systems and tools.

Preferably, the tool comprises means for connecting the subsea unit to an ROV (remotely operated vehicle) for power and control of the subsea unit from a
30 topside control unit via the ROV and its umbilical. The means for connecting to an ROV is preferably one or more docking stations with receptacles and connectors operatively connectable with corresponding means of the ROV. Connectors are separate or common for hydraulic power, electric power and

signals, most ROV operators can provide such connectors, for example hot stabs with inductive or contact connectors for electric power and/or signals.

5 The means for positioning preferably comprises thrusters integrated in the tool and thrust force applied from optional docked ROV's, in addition to a crane on the ship. Also the lifting lugs, spreaders, etc, can be considered as means for positioning, allowing positioning by being hung up in a crane wire or rope.

10 The subsea unit preferably comprises means for determining the position and orientation, comprising a gyro in the subsea unit, the positioning system of an optionally connected ROV, and optional further position sensors in the subsea unit, wellhead modules and equipment, and wellhead instrumentation, and optional cameras on the tool and wellhead modules or equipment.

15 The tool comprises means for testing and commissioning, preferably comprising fluid banks, such as nitrogen gas accumulators and cylinders for seal and pressure testing; and means for mechanical connection to the wellhead and disconnection of the subsea unit after operation testing of mechanical functions, such as valve functions, and hydraulic liquid filling, such as an MEG bank and a
20 hydraulic power unit in the subsea unit or/and in an optional ROV system connected via hot stabs or similar. Preferably the subsea unit has a hydraulic power unit comprising a hydraulic motor driven by the hydraulics of the ROV, the hydraulic circuits of the subsea unit conveniently using MEG as hydraulic fluid.

25

The invention also provides a method for installation of subsea wellhead modules or equipment, such as a XT (Christmas tree), from a ship using a ship crane, using the tool of the invention, distinctive by deploying the wellhead module or equipment releasably connected to the subsea unit of said tool, using
30 a mechanical connector and the ship crane but without umbilical or line providing liquid or gas from the surface, but using the tool as connected to a fluidless electrical or electrical-optical umbilical or a ROV for positioning and connecting to a subsea wellhead.

Preferably the method also comprises steps for pressure and function testing, and disconnecting the tool from the wellhead module or equipment after said testing.

- 5 Further, the invention provides means for pressure testing of subsea wellhead modules or equipment, distinctive in that the means comprises a gas filled accumulator and a gas filled cylinder, having connectors for sealingly mechanical connection and connectors for power and control, for operatively connecting to the subsea wellhead module or equipment for testing. The means
10 is included in the tool of the invention or is included or releasably connected to other subsea equipment, like pumps, compressors and subsea modules.

Also, the invention provides a method for installation of subsea wellhead modules such as Xmas trees and similar equipment, from a ship using a ship
15 crane, using the tool of the invention, distinctive by:

- sealingly connecting a gas filled accumulator and a gas filled cylinder, and connectors for power and control, to the subsea module or equipment,
evacuating water from the volume to be tested, by opening the accumulator in order to displace the water with gas,
20 pressurizing to test pressure, by operating the cylinder, and monitoring the pressure for a prescribed period of time.

Figures

The invention is illustrated with four figures, of which:

- 25 Figure 1 illustrates a tool according to the invention, before connection to a wellhead,
Figure 2 illustrates the tool of Fig. 1, still before connection to a wellhead, but as connected to a ROV,
Fig. 3 illustrates the tool of Fig. nos 1 and 2, as connected to a wellhead, and
30 Fig. 4 is a more detailed illustration of a tool of the invention.

Detailed description

Reference is made to Fig. 1, illustrating a tool according to the invention, more specifically a subsea unit 1 of the tool, as releasably connected to a subsea x-

mas tree 2, for connection to a subsea wellhead 3. The assembly is deployed as hanging from a ship 4. Also, a ROV 5 is illustrated, operated from the ship. Reference is then made to Fig. 2, illustrating that the ROV has docked to the subsea unit 1. In the illustrated embodiment, the assembly of the subsea unit 1 and the x-mas tree 2 hangs in a rope from the ship, and electric power and control signals are provided via the ROV, via the electrical-optical umbilical of the ROV, using the hydraulic power unit of the ROV for driving a hydraulic system of the subsea unit via a hydraulic converter pump. Alternatively, the subsea unit could be directly connected to a fluidless umbilical, the subsea unit per se including all means for operating and testing mechanical, electrical and any other devices, or the means could be provided from the ROV system to a full or larger extent. Also, an observation ROV can be used to facilitate the operation. The illustrated subsea unit weighs about 24 metric tons, the releasably connected x-mas tree weights about 40 metric tons. Fig. 3 illustrates the x-mas tree 2 as connected to the wellhead 3. After testing connection, valve functions and communication with all sensors in the subsea system, the subsea unit 1 is disconnected from the x-mas tree.

Fig. 4 is a more detailed illustration of a tool of the invention. Similar items are designated with the same reference numerical in all figures. Fig 4 clearly shows inter alia a ROV docking station on the subsea unit, as receptacles 6 and hot stab ports 7 are illustrated.

CLAIMS

1.

5 Tool for subsea installation and testing of wellhead modules such as Xmas trees and similar equipment, from a ship using a ship crane, c h a r a c t e r i s e d i n that the tool comprises a subsea unit comprising a connector for releasable connection to subsea wellhead modules or equipment, means for positioning and means for testing, and a connector for electric power and electric and/or optical control.

10

2.

15 Tool according to claim 1, c h a r a c t e r i s e d i n that the tool has no supply of hydraulic liquid or gas via umbilical or other pressure line from the surface, as only electric power and electric and/or optical control signals are transferred between the surface position and the wellhead area.

3.

20 Tool according to claim 1 or 2, c h a r a c t e r i s e d i n that it comprises means for connecting the subsea unit to an ROV (remotely operated vehicle) for power and control of the subsea unit from a topside control unit via the ROV and its umbilical.

4.

25 Tool according to claim 1, c h a r a c t e r i s e d i n that the means for positioning comprises thrusters integrated in the tool and thrust force applied from optional docked ROV's, in addition to a crane on the ship.

5.

30 Tool according to claim 1, c h a r a c t e r i s e d i n that the subsea unit comprises means for determining the position and orientation, comprising a gyro in the subsea unit, the positioning system of an optionally connected ROV, and optional further position sensors in the subsea unit, wellhead modules and equipment, and wellhead instrumentation, and optional cameras on the tool and wellhead modules or equipment.

6.

5 Tool according to any one of claim 1-5, c h a r a c t e r i s e d i n that the
tool comprises means for testing and commissioning, comprising fluid banks,
such as nitrogen gas accumulators and cylinders for seal and pressure testing;
and means for mechanical connection to the wellhead and disconnection of the
subsea unit after operation testing of mechanical functions, such as valve
functions, and hydraulic liquid filling, such as MEG banks and hydraulic power
10 unit in the subsea unit or in an optional ROV system connected via hot stabs or
similar.

7.

15 Method for installation of subsea wellhead modules such as Xmas trees and
similar equipment, from a ship using a ship crane, using the tool of any one of
claims 1-6 , c h a r a c t e r i s e d b y deploying the wellhead module or
equipment as releasably connected to the subsea unit of said tool, using the
ship crane but without any umbilical or line providing liquid or gas from the
surface, but using the tool as connected to a fluidless electrical or electrical-
20 optical umbilical or a ROV for positioning and connecting to a subsea wellhead.

8.

Method according to claim 6, c h a r a c t e r i s e d i n that the method also
comprises steps for pressure and function testing, and disconnecting the tool
25 from the wellhead module or equipment after said testing.

9.

Means for pressure testing of subsea wellhead modules or equipment,
c h a r a c t e r i s e d i n that the means comprises a gas filled accumulator
30 and a gas filled cylinder, having connectors for mechanical seal connections
and connectors for power and control, for operatively connecting to the subsea
wellhead module or equipment for testing.

10.

Method for pressure testing of subsea wellhead modules or equipment, using the means of claim 9, c h a r a c t e r i s e d b y

- 5 sealingly connecting a gas filled accumulator and a gas filled cylinder, and connectors for power and control, to the subsea module or equipment, evacuating water from the volume to be tested, by opening the accumulator in order to displace the water with gas, pressurizing to test pressure, by operating the cylinder, and
- 10 monitoring the pressure for a prescribed period of time.

1/4

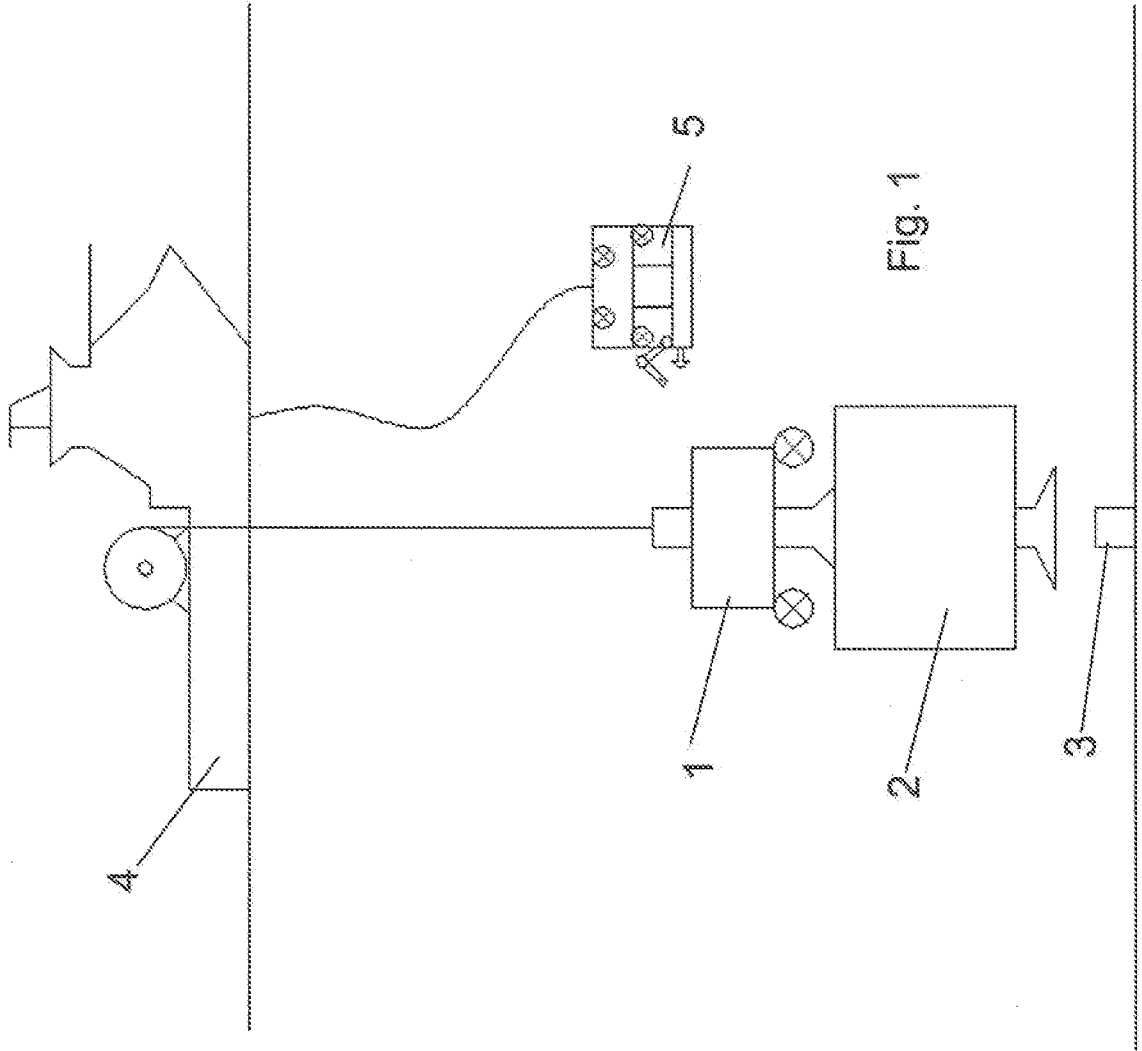

Fig. 1

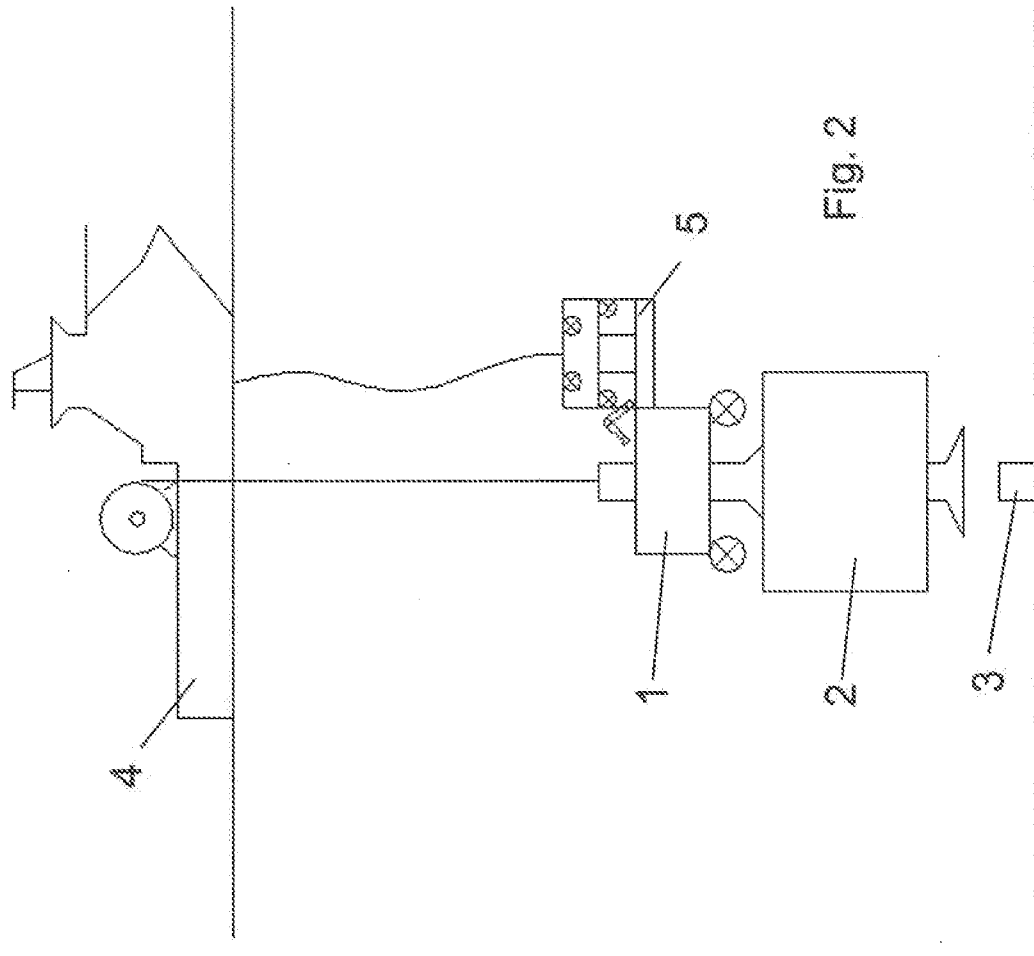

Fig. 2

3/4

