

No. 812,701.

PATENTED FEB. 13, 1906.

J. H. STINER.
TACK PULLER.

APPLICATION FILED JULY 11, 1905.

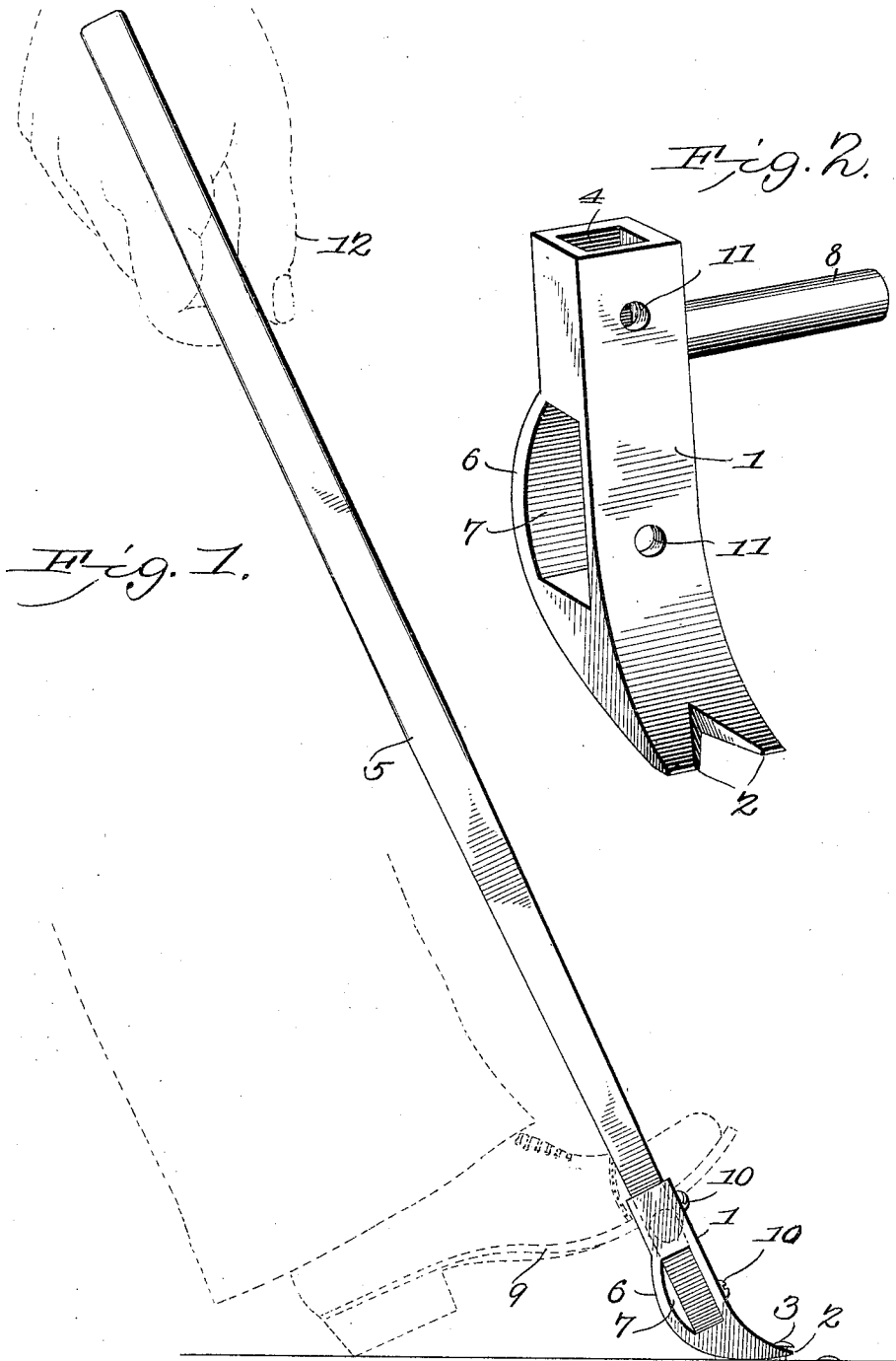

Witnesses

E. Stewart
L. J. Morrill

James H. Stiner, Inventor

by *C. A. Snow & Co.*
Attorneys

UNITED STATES PATENT OFFICE.

JAMES HERVEY STINER, OF GOWEN, PENNSYLVANIA.

TACK-PULLER.

No. 812,701.

Specification of Letters Patent.

Patented Feb. 13, 1906.

Application filed July 11, 1905. Serial No. 269,239.

To all whom it may concern:

Be it known that I, JAMES HERVEY STINER, a citizen of the United States, residing at Gowen, in the county of Luzerne and State of Pennsylvania, have invented a new and useful Tack-Puller, of which the following is a specification.

This invention relates to tack-pullers, and has for its object to produce a device of the class embodying new and improved features of convenience and reliability of action.

A further object of the invention is to provide a device wherewith a tack may be pulled from the floor while the operator is in a standing position.

A further object of the invention is to provide a device to be operated conjointly by a hand and a foot of the operator.

With these and other objects in view the present invention consists in the combination and arrangement of parts, as will be hereinafter fully described, shown in the accompanying drawings, and particularly pointed out in the appended claim.

In the drawings, Figure 1 is a view in side elevation of the improved tack-puller with a hand and a foot in operative position thereon. Fig. 2 is a perspective view of the head of the improved tack-puller.

Like characters of reference indicate corresponding parts in both figures of the drawings.

In its preferred embodiment the invention forming the subject-matter of this application comprises a head 1, having at one end a claw 2, arranged and proportioned to engage a tack 3, and having a socket 4 formed in its opposite end proportioned to receive the handle 5. Intermediate the ends the head is provided upon its lower side with a fulcrum-curve 6, and for economy of material and weight the head may be formed with the transverse aperture 7. Upon the side, normally the left, the head is provided with an outstanding rigid arm 8, proportioned and

disposed conveniently for engagement by a foot 9.

The handle 5 may be secured in the socket 4 by any approved means, as the screws 10 through the holes 11, and is of a length to be conveniently grasped by a hand 12 when the operator is in a standing position.

From the foregoing it will be understood that the claw 2 is placed upon the floor adjacent the tack 3 and the foot 9 placed on the arm 8, forcing the claw downward against the resistance of any elastic material, as a carpet, and under the head of the tack. When the tack-head is engaged by the claw, the puller is held in engagement by the foot, and the hand depresses the extremity of the lever, drawing the tack.

It will be noted that this device is arranged and proportioned to enable the pulling of the tacks without kneeling or stooping to a painful and wearying extent.

Having thus described the invention, what is claimed is—

A tool of the class described comprising a head having an angular socket formed in one end thereof and having its opposite end reduced and provided with a V-shaped notch forming a gripping-claw, said head being provided with a transverse recess communicating with the socket and having one wall thereof formed with a plurality of openings and the adjacent wall curved laterally to form a fulcrum, an arm projecting laterally from the head at said socket, an operating-handle seated in the socket, and fastening devices passing through the openings and engaging the adjacent end of the operating-handle.

In testimony that I claim the foregoing as my own I have hereto affixed my signature in the presence of two witnesses.

JAMES HERVEY STINER.

Witnesses:

JOHN WILHELM,
I. G. ECKERT.