

P. W. SOMMER.
 SAFETY APPLIANCE FOR ELEVATORS.
 APPLICATION FILED OCT. 14, 1908.

998,416.

Patented July 18, 1911.

2 SHEETS—SHEET 2.

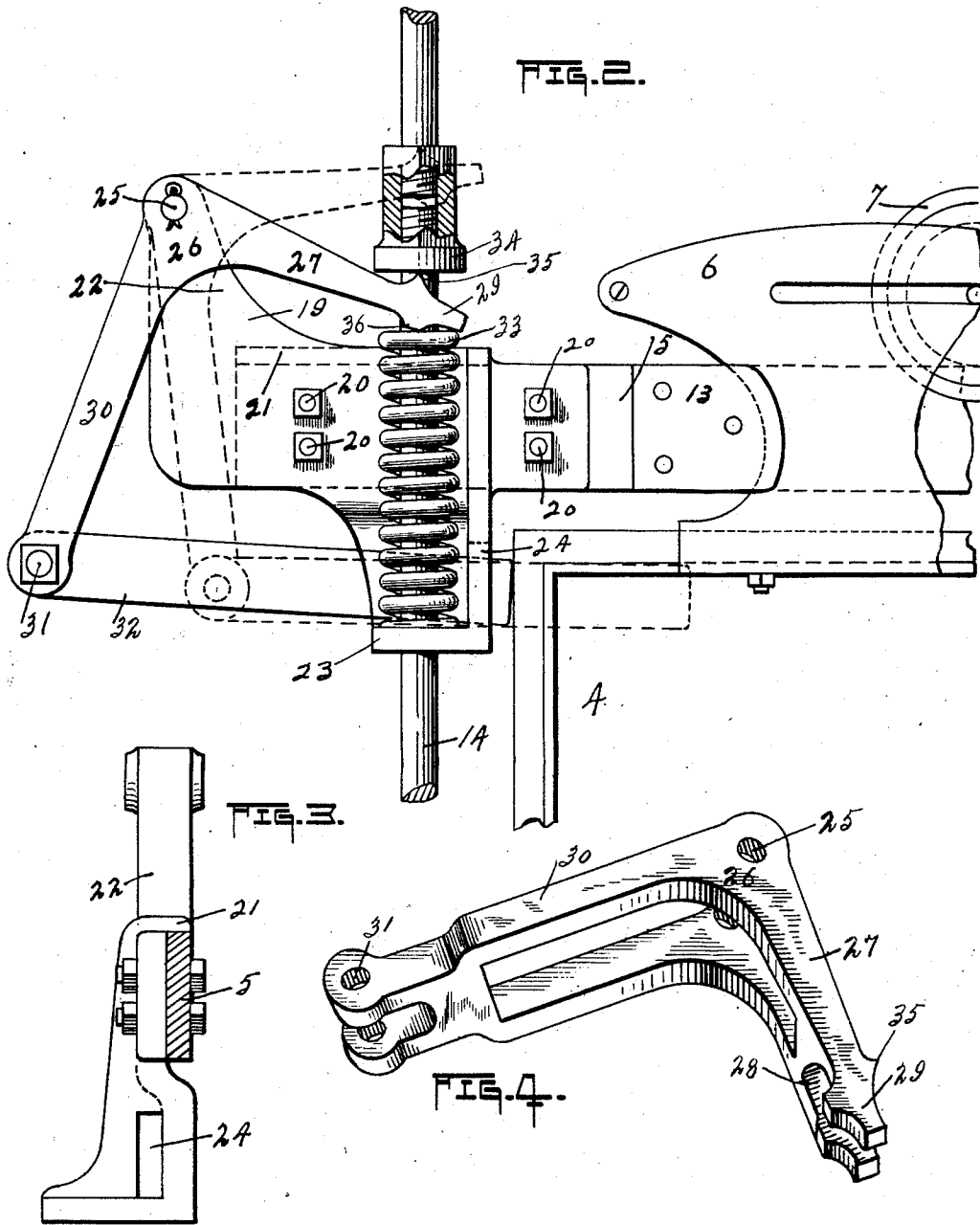

Witnesses:
 H. V. Gibson.
 L. E. Chappool.

Inventor.
 By Peter W. Sommer
 Chas. A. MacPonte
 Atty.

UNITED STATES PATENT OFFICE.

PETER W. SOMMER, OF PEORIA, ILLINOIS.

SAFETY APPLIANCE FOR ELEVATORS.

998,416.

Specification of Letters Patent. Patented July 18, 1911.

Application filed October 14, 1908. Serial No. 457,613.

To all whom it may concern:

Be it known that I, PETER W. SOMMER, a citizen of the United States, residing at Peoria, in the county of Peoria and State of Illinois, have invented certain new and useful Improvements in Safety Appliances for Elevators; and I do hereby declare that the following is a full, clear, and exact description of the invention, which will enable others skilled in the art to which it appertains to make and use the same.

This invention has reference to safety appliances for elevators and has for its object to provide mechanism operatively connected with the power for raising or lowering the elevator car, and arranged to be operated by the floor doors, whereby when a door or doors on the several floors communicating with the elevator shaft, are closed, the power for operating the elevator is placed in operative connection therewith, so that the elevator may be raised or lowered, but when any one of said door or doors are opened, the mechanism will be operated for shutting off the power, thereby bringing the elevator to a standstill, and the power can not be employed or connected up with the elevator until the said door or doors which have been opened, are closed.

The invention has for its further object to provide a safety appliance for elevators, where the power employed for operating the elevator, that it may be raised or lowered, is operatively connected with mechanism under the control of or arranged to be actuated by the door or doors communicating with the elevator shaft, and wherein it is necessary for the operator of the elevator car to absolutely close and latch the floor door communicating with the elevator shaft and car, if coincident therewith, before power may be communicated to the car, or the means connected therewith, for raising or lowering the same, and that immediately upon the unlatching of the door, the mechanism controlled thereby, will be automatically operated for disconnecting the power connected to and employed for raising and lowering said car.

For a further and full description of the invention herein and the merits thereof and also to acquire a knowledge of the details of construction of the means for effecting the result, reference is had to the following description and drawings hereto attached.

While the essential and characteristic fea-

tures of the invention are susceptible of modification, still the preferred embodiment of the invention is illustrated in the accompanying drawings, in which:—

Figure 1 is a greatly reduced view in elevation of so much of an elevator casing and floor door as will illustrate the application of my improved appliances thereto; the mechanism is viewed from the inside of the elevator shaft and omits the elevator car; Figure 2 is an enlarged elevation of the mechanism controlled or operated by the floor door by means of which the power for raising or lowering the elevator may be communicated to the elevator when the floor door is shut, and shut off from the elevator when the floor door is open; the full lines indicating that the power is in communication with the car, and in dotted lines, showing the position of the parts when the door would be open and the power shut off from the car; Figure 3 is an end view of a bracket or support for the mechanism under the control of the floor door, and Figure 4 is a perspective view of a bell-crank lever forming a part of the mechanism, best seen in Figure 2.

Like numerals of reference indicate corresponding parts throughout the figures.

Before proceeding with a detail description of the mechanism which I employ, operatively connected with the power which is used for raising and lowering an elevator car, and which is under the control of the floor doors communicating with the elevator shaft, I wish it understood that the elevator car itself or the mechanism associated therein for turning off or on the power which will raise or lower the car, does not enter into my invention nor have such elements anything to do with the operation of the same, whereby it will be understood that the operator in the car has no control over the mechanism which I employ, except as he may open or close the floor doors communicating with the elevator shaft, and that the operation of the levers or other mechanism which may be employed in the car, whereby he controls the movement of the car, has nothing to do with my invention, nor is the operation of my invention dependent upon the position of the elevator car in the elevator shaft, because the mechanism may be actuated by opening or closing the floor doors from the inside of the elevator shaft or from the

outside, and should any one of said floor doors be open, the position of the elevator car in the shaft is immaterial, the mechanism will be operated which will disconnect the power from the elevator and stop the elevator, and the elevator cannot be moved by its power until the door has been closed.

I am aware that appliances have been employed in connection with elevator cars so that when the floor door has been opened, mechanism will be operated by the door for locking the lever or other means within the car, so that the operator of the car cannot move the same for the purpose of transmitting power to raise or lower the car, and that as soon as he closes the door, his lever or other operating means is released, enabling him to have control thereof for imparting movement to the car; but his car must always be moved into a position opposite a floor level or coincident with a floor door so that when the door is open, the mechanism can engage the lever or other means in the car for locking the same; however, as above stated, it will be observed that my improvements are operated in an entirely different way, and that I have nothing to do with the lever or other operating mechanism in the car, but go directly to the source of power, by means of which the car is raised or lowered.

Proceeding now with the description of the mechanism by means of which I obtain the results previously referred to, 1 designates an elevator shaft which may be of any suitable depth and communicate with as many doors as may be desirable, and on each floor of a building surrounding or partially surrounding the said shaft, is a casing 2 provided with a door opening 3, and 4 designates a sliding door adapted to close said opening. Such doors are usually hung on a track 5, by providing the door with brackets 6, in which are journaled rollers 7 which travel on the track 5. For maintaining the door closed after it has been shut, or moved into a closed position, there is provided a latch 8, pivoted at 9 to the door and provided with the hook 10 operating in the member 11 secured to the casing 2 or other support, to engage a lug 12. To release the door, the operator of the elevator car will throw the latch 8 to the right, looking at Fig. 1, which will raise the hook 10 from engagement with the lug 12, allowing the door to be opened by sliding the same along the track 5, and upon a reverse operation being imparted to the door, it will be seen that the hook 10 will enter the member 11 and secure the door in a closed position.

I have described a usual form of construction of door supporting and securing means used upon elevator shafts or casings therefor, but I wish it to be understood that it is

immaterial as to the character of the door, its mounting, so that it may be opened or closed, or the securing means for latching the door shut, so long as such means are employed, and with my improvements, it is practically necessary that some such means as the latch 8 be provided for locking the door closed, otherwise, as will become apparent, the door will be thrown open, and the car be inoperative, until the door has been firmly closed and latched.

For stopping or limiting the movement of the door 4 when it is open, any suitable stop or buffer may be provided, likewise a stop or buffer may be provided for retarding the movement of the door after it reaches its closed position. Such a device is shown in the form of a buffer 13 attached to the track 5, with which the left hand bracket 6, shown in Fig. 1, is adapted to engage when the door has reached its closed position, and the hook 10 of the latch 8 assumes a locking relation with the lug 12.

14 denotes a rod, bar or similar member which is disposed vertically in the elevator shaft, and at a suitable position therein, preferably in proximity to the wall of the door opening, with which coincides the edge of the door supporting the latch 8, and said rod 14 will preferably extend down into the basement or lower portion of a building where the power which is employed for raising or lowering the elevator, is located, and said rod, at its lower end will be operatively connected in some suitable and practical manner with such power, whether it be hydraulic or other power; the character of the power employed to be connected to and engage with the elevator car or cars for raising or lowering the same, being immaterial, as also the connections between the rod 14 and such power, for whatever its character, the connection between the rod and such power will have to be modified, so that when said rod moves in one direction, the power may be cut off from the car, so that the car cannot be operated, and when moving in an opposite direction, the power may be connected with the car, so that the car may be moved, and such connections between the rod and the power, whereby the power is controlled by the operation of the rod so as to regulate the movement of the elevator, has nothing to do with the controlling means regulated by the control of the lever or other operating means in the car, that the car may be stopped at any desired position in the elevator shaft. In the preferred construction of my invention, and as will be understood from the further description of the same, the rod 14 is maintained to have vertical motion or be reciprocated lengthwise in the elevator shaft, but I do not desire to be limited to such motion, as I realize that the mechanism associated with said rod, may be

modified, so that the rod may be rocked, rather than be reciprocating, so as to control the power for operating the car, and the car itself.

5 The rod 14 will extend to a point in the elevator shaft or building above the highest
 * point of movement of the elevator car, and
 be pivotally connected as at 15, with a lever
 16, fulcrumed at 17 and said lever 16 has
 10 connected therewith, at its opposite end,
 the weight 18 or equivalent means. The ob-
 ject of the weight 18 and lever connection
 with the rod 14, is to form a balance for the
 rod 14, not that it is desired to have the rod
 15 14 perfectly balanced, but so that the rod
 14 will overcome to a sufficient degree, the
 weight of the weight 18, so that in the event
 that no means was applied to the rod 14 for
 preventing its lowering or raising the
 20 weight 18, said rod would overcome the
 weight and drop of its own accord.

Secured to the track 5, on which the ele-
 vator door is hung, is shown a bracket 19,
 which is bolted thereto, as at 20, or may be
 25 fixedly secured thereto in any suitable man-
 ner. Such a bracket is intended to be se-
 cured to the track for each door of the ele-
 vator shaft throughout the building, and is
 supported adjacent to the wall of the ele-
 vators casing with which the front edge of
 30 the door coincides when said door is closed.

The bracket 19 is best seen in Figs. 2 and
 3, where it is shown having a lip 21 overly-
 ing and engaging the upper edge of the
 track 5, and further provided with the up-
 35 wardly extended arm 22, and also with a
 boss 23 at or near its lower end, and a slot
 24 in the inner end of the wall or web of
 said bracket, as best seen in Fig. 3. The rod
 40 14 passes up through and has a bearing in
 the boss 23 of the bracket 19, and wherever
 such brackets are provided or secured to the
 track 5, it is intended that each shall have
 a boss similar to 23, forming a bearing for
 45 the rod 14, and these are the only bearings for
 the rod which I have shown, although, if it
 is desired, other bearings or supports there-
 for, may be provided.

Pivotally connected to the arm 22 at 25 is
 50 a bell-crank lever 26, preferably of that
 shape shown in Fig. 4, with the forward
 end of the portion 27 of said lever slotted,
 as at 28, to allow for the carrying of the
 rod 14 between the bifurcated ends 29, which
 55 form the slot just referred to; while to the
 lower end of the portion 30 of the lever 26;
 pivotally connected at 31, is an arm or bar
 32 which passes through and has movement
 in the slot 24 of the bracket 19, as shown in
 60 Fig. 2. The free end of the arm or bar 32,
 is in the same longitudinal plane with the
 door 4, and is adapted to be engaged by the
 front edge of the door when said door is
 moved to a closed position, and when so en-
 65 gaged, said arm or bar 32 will be recipro-

cated in the slot 24 of the bracket, which, in
 turn oscillates the bell-crank lever 26, on
 its pivot 25 and moves it into that position
 shown in full lines in Fig. 2. When the door
 is opened or moved away from the free end
 70 of the bar or arm 32, a coil spring 33 which
 is carried about the rod 14 between the boss
 23 of the bracket 19, and the forward end of
 the portion 27 of the lever 26, will operate
 to oscillate the lever 26 on its pivot 25, and
 75 throw said lever and the arm or bar 32 into
 that position shown in dotted lines in Fig. 2.
 Secured to the rod 14 above the portion 27
 of the lever 26 and adapted to engage with
 said portion 27 of the lever, is a collar 34, or
 80 similar member, which together with the
 rod, is raised by the portion 27 of the lever
 26 when said lever is moved into that posi-
 tion shown in dotted lines in Fig. 2, when
 the spring 33 acts immediately upon the re-
 85 lease of the arm or bar 32 by the movement
 of the door away from the end thereof, but
 as said door engages with the arm or bar 32
 and throws the lever 26 into the position
 shown in full lines in Fig. 2, and lowers the
 90 portion 27 thereof, it will be seen that the
 rod 14 with the collar 34 will drop by weight
 of gravity and bring the collar 34 into en-
 gagement with the upper face of the portion
 27 of the lever 26. As previously explained,
 95 it is the downward movement of the rod 14
 which operates the connection between said
 rod and the power for allowing the elevator
 car to be operated to be raised or lowered, and
 that with the upward movement of the rod
 100 14, the connections between said rod and the
 power is actuated, so as to prevent opera-
 tion of the car.

I prefer to provide the upper faces of the
 bifurcations 29 of the portion 27 of the lever
 105 26 with the knife edges or wedge shaped
 portions 35, which produce a suitable bear-
 ing for the bell-crank lever 26 against the
 collar and the rod connected therewith;
 likewise, I provide the lower faces of the
 110 bifurcations 29 with the lugs or projections
 36, operating in connection with the spring
 33 in a similar manner to the portions 35
 with the collar 34.

It is not intended that the rod 14 shall be
 115 one piece throughout its length, but rather,
 in the preferred construction, the rod will
 be made in sections and extend from floor
 to floor and the matching edges of the sec-
 tions, have a detachable connection with the
 120 collars 34, as shown in Fig. 2

From the foregoing description, it will be
 observed that if the latch 8 is not caught
 when the door 4 is closed, that the coil
 spring will operate the bell-crank lever 26
 125 to move the rod 14 to an inoperative position
 and thereby prevent the operator in the car
 from transmitting motion to said car for
 moving it either up or down, and that he
 must see that the door is closed and latched
 130

for throwing the bell-crank lever 26 into the position shown in full lines in Fig. 2 to insure the rod 14 being moved into a position to enable him to transmit power to the car for raising or lowering the same.

While I have shown the invention as applied to a door opening in an elevator shaft where only one door is used, for closing the same, I do not overlook the fact that to be practical the invention must be applicable to door openings where two sliding doors are employed, and which, when closed, meet at the center of the door opening. To apply my invention to such doors, it is of course understood that the mechanism operated by the door will have to be modified to some extent, so as to be operated upon the closing of the doors, and one method of doing this would be to increase the length of the arm or bar 32 and suitably connect it with the door so as to be operated for throwing the bell-crank lever when the doors were closed, and such an arrangement might entail a rearrangement of the bell-crank lever for controlling the rod 14, and I wish it understood that I contemplate such application of the invention.

I have referred to the fact that the rod 14 may be rocked instead of being reciprocated, and in addition to this, I wish it to be understood that two rods could be employed instead of one, the raising of one rod disconnecting the power so that the elevator would be inoperative until the lowering of the other rod, which would operate connections, so that power could be transmitted to the car for raising or lowering the same.

Having thus fully described my invention, what I claim and desire to secure by Letters Patent of the United States, is:—

1. In a safety appliance for elevators, the combination with the elevator shaft and floor doors and a latch for locking each door closed, of a member arranged in said shaft with portions thereof in proximity to the door openings and having one end operatively connected with power for operating a car, a lever pivotally supported coincident with each door opening and adapted to be operated by the door, when the door is closed, whereby said member will be moved in one direction, and yielding means carried around said member and associated with said lever and adapted to operate the lever upon the opening of the door, for moving the said member in an opposite direction, substantially for the purposes specified.

2. In a safety appliance for elevators, the combination with the elevator shaft and floor doors and a latch for locking each door closed, of a rod reciprocally mounted in said shaft and having one end operatively connected with power for operating a car, a lever pivotally supported in proximity to

each door opening and cooperating with said rod, means cooperating with said levers for actuating the same to raise the rod when their respective doors are opened, and means connected with said levers and adapted to be operated by the doors as the same are closed for moving said levers into a position, whereby said rod may be allowed to drop of its own weight, substantially for the purposes specified.

3. In a safety appliance for elevators, the combination with the elevator shaft and floor doors and a latch for locking each door closed, of a rod reciprocally mounted in said shaft and having one end operatively connected with power for operating a car, a lever pivotally supported in proximity to each door opening, a member to cooperate with each lever and attached to said rod, a spring associated with each lever, operating when the doors are opened to move the lever for raising the rod by engagement with the members thereon, and a bar pivotally connected with said levers and capable of being operated by the closing of the doors for moving said levers and thereby compressing the spring associated therewith, whereby and during the compression of such spring, the rod will be allowed to drop.

4. In a safety appliance for elevators, the combination with the sliding door and a latch for locking said door closed, of a reciprocally supported rod operatively connected at one end with the power for operating the car, said rod capable of being retained in an operative position by weight of gravity, a lever associated with said rod, means for operating the lever to raise the rod into an inoperative position upon the opening of the door, and means connected with said lever and adapted to be operated by the door as it is closed, for moving said lever, and thereby allowing said rod to drop and assume its operative position.

5. In a safety appliance for elevators, the combination with the elevator shaft, the sliding door, a latch for locking the door closed, and the track on which the door is hung, of a rod reciprocally mounted in said shaft and operatively connected at one end with the power for operating a car, a bracket supported by said track and forming a bearing for said rod, a lever pivotally connected with said bracket, one end of which is associated with said rod, a member attached to said rod and adapted to be engaged by said lever, a bar pivotally connected with said lever and adapted to be operated by the door as it is closed for moving said lever and allowing the rod to assume an operative position, and a spring encircling said rod and bearing between the portion of the lever associated with the rod and the bracket, whereby as the door is opened, the spring will be

allowed to act for operating the lever which engaging with the member on the rod, will move said rod to an inoperative position.

6. In a safety appliance for elevators, the combination with a sliding door and a latch to lock the door closed, of a rod operatively connected with the power for operating a car, a bracket suitably supported and forming a bearing for said rod, a lever pivotally connected with said bracket and having a slotted end associated with said rod, a coil spring surrounding the rod between the slotted end of the lever and the bearing formed on the bracket therefor, a bar connected with said lever and adapted to be op-

erated by the door as the door is closed for moving said lever and compressing said spring to allow said rod to assume an operative position, and means on the rod adapted to be engaged by the lever through the action of the spring when the door is opened, for moving said rod to an inoperative position. 20

In testimony whereof I affix my signature, in presence of two witnesses.

PETER W. SOMMER.

Witnesses:

CHAS. W. LA PORTE,
LAURA E. CLAYPOOL.

Copies of this patent may be obtained for five cents each, by addressing the "Commissioner of Patents, Washington, D. C."