



US00D683025S

(12) **United States Design Patent**
Banryu

(10) **Patent No.:** **US D683,025 S**

(45) **Date of Patent:** **** May 21, 2013**

(54) **SCANNER FOR A MAGNETIC RESONANCE TOMOGRAPHY DIAGNOSIS APPARATUS**

Extract of Nikkei Sangyo Shimbun (Newspaper) "Showing a Magnetic Resonance Imaging." (Siemens AG/Type 3T) Received Jun. 30, 2011.

(75) Inventor: **Atsunobu Banryu**, Funabashi (JP)

* cited by examiner

(73) Assignee: **Kabushiki Kaisha Toshiba** (JP)

Primary Examiner — Anhdao Doan

(**) Term: **14 Years**

(74) *Attorney, Agent, or Firm* — Banner & Witcoff, Ltd.

(21) Appl. No.: **29/422,438**

(22) Filed: **May 21, 2012**

(57) **CLAIM**

The ornamental design for a scanner for a magnetic resonance tomography diagnosis apparatus, as shown and described.

(30) **Foreign Application Priority Data**

Nov. 22, 2011 (JP) 2011-026931

(51) **LOC (9) Cl.** **24-01**

(52) **U.S. Cl.**

USPC **D24/158**

(58) **Field of Classification Search** D24/158-161,
D24/185, 186; 378/4, 15, 17, 20, 21, 23-27,
378/62, 68, 146, 195-198

See application file for complete search history.

DESCRIPTION

FIG. 1 is a front perspective view of a scanner for a magnetic resonance tomography diagnosis apparatus, showing my new design;

FIG. 2 is a rear perspective view thereof;

FIG. 3 is a front elevational view thereof;

FIG. 4 is a rear elevational view thereof;

FIG. 5 is a left side elevational view thereof;

FIG. 6 is a right side elevational view thereof;

FIG. 7 is a top plan view thereof;

FIG. 8 is a bottom plan view thereof;

FIG. 9 is a cross sectional view thereof, taken along the line 9-9 in FIG. 3; and,

FIG. 10 is an enlarged view thereof, taken along the line 10-10 in FIG. 9.

The broken line showings in FIGS. 9-10 are for the purpose of illustrating unclaimed portions of the scanner for a magnetic resonance tomography diagnosis apparatus. The broken lines form no part of the claimed design.

The recess visible in the cross section extends consistently around the center region from 7 o'clock to 5 o'clock.

The radial lines emanating from around the center region in FIGS. 1, 3, 5-10 indicate illumination.

(56) **References Cited**

U.S. PATENT DOCUMENTS

D399,958 S *	10/1998	Hiramatsu	D24/158
D420,134 S *	2/2000	Kitayama	D24/159
D557,418 S *	12/2007	Onuma et al.	D24/158
D564,096 S *	3/2008	Banryu	D24/158
D625,416 S *	10/2010	Kasai et al.	D24/158
D628,294 S *	11/2010	Baba	D24/158

FOREIGN PATENT DOCUMENTS

JP	1312242	10/2007
JP	1312245	10/2007
JP	1370351	10/2009

OTHER PUBLICATIONS

Extract of Nikkei Sangyo Shimbun (Newspaper) "Showing a Magnetic Resonance Imaging." (Siemens-Asahi Medical Technologies Ltd/Magnetom Essenza).

1 Claim, 9 Drawing Sheets

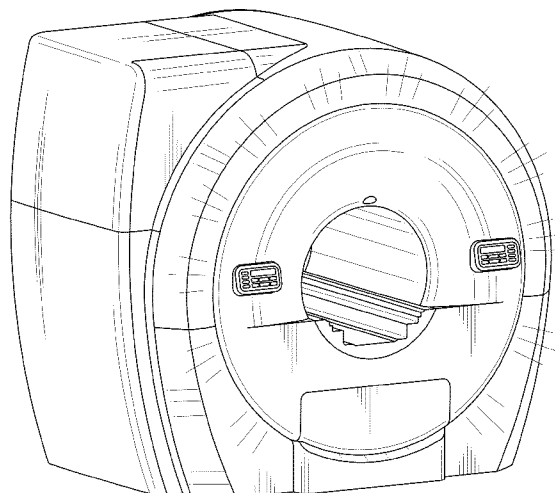

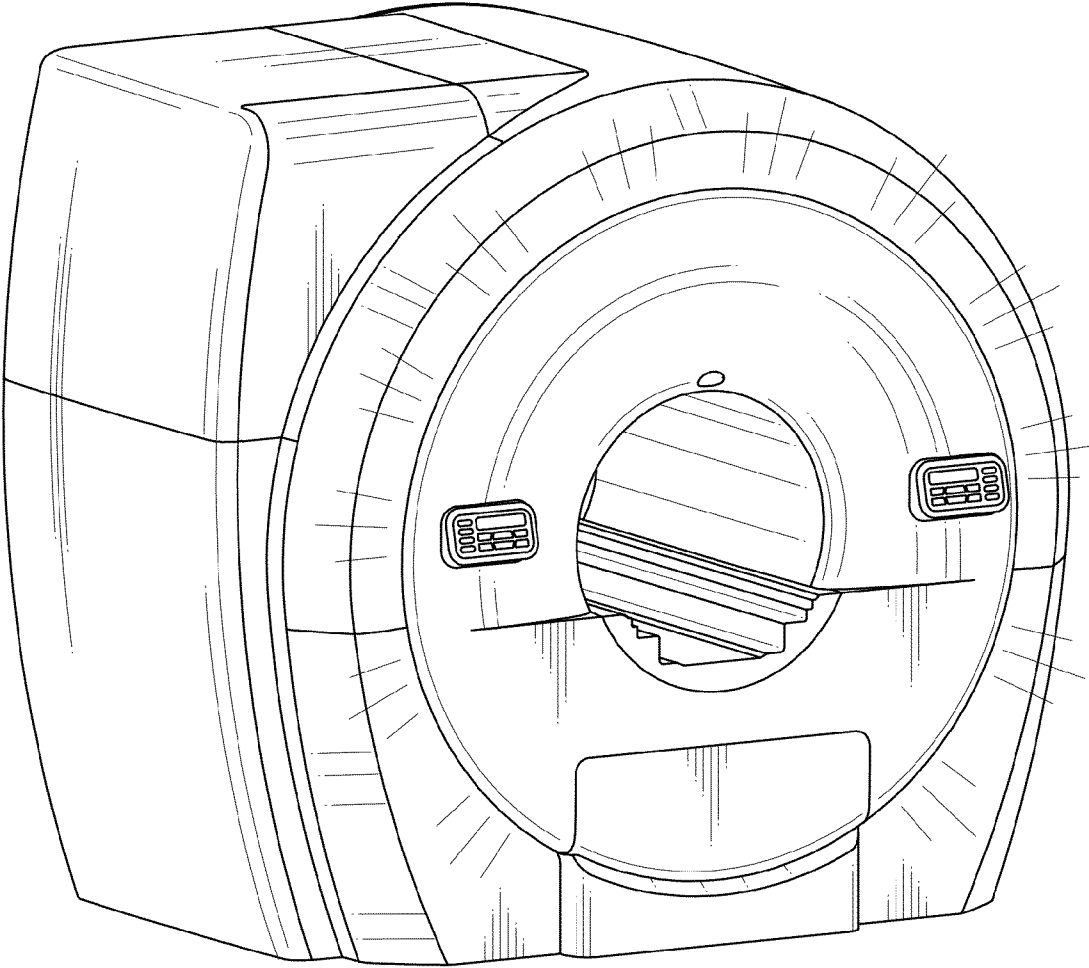

FIG. 1

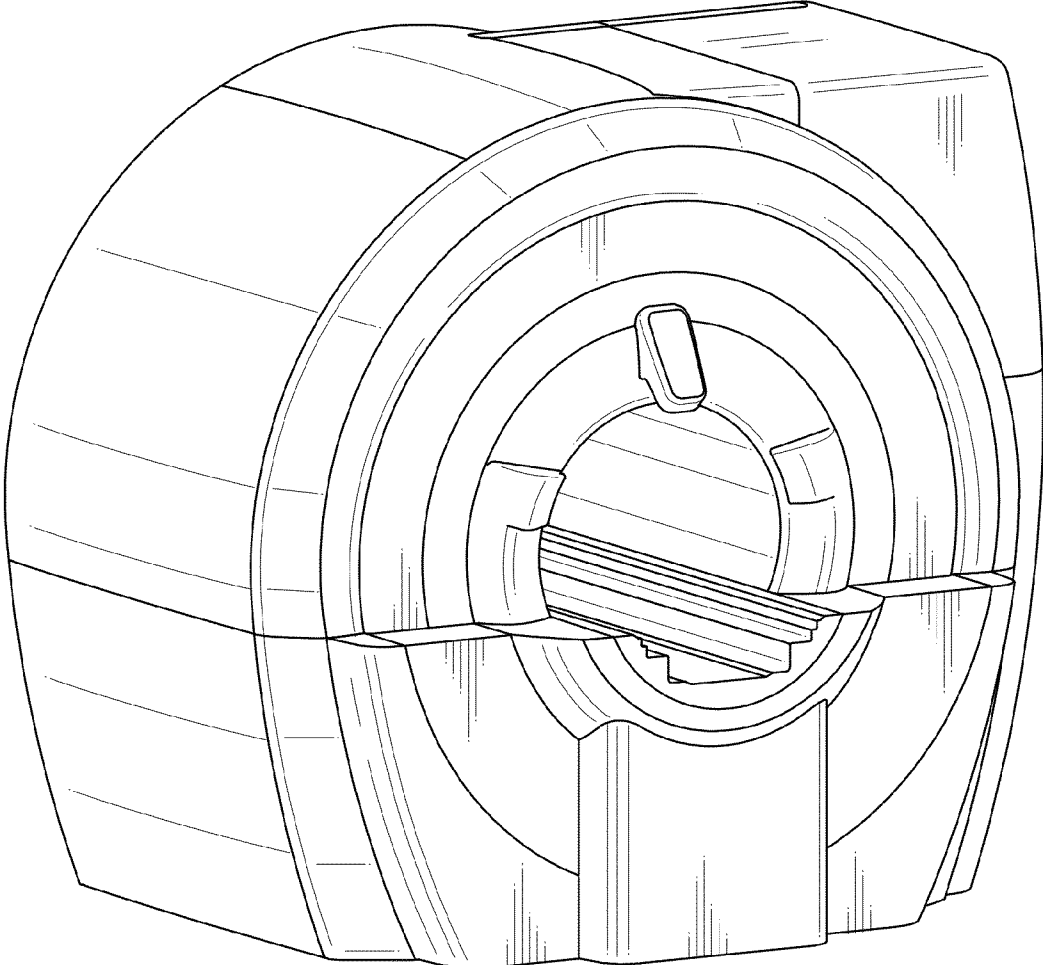

FIG. 2

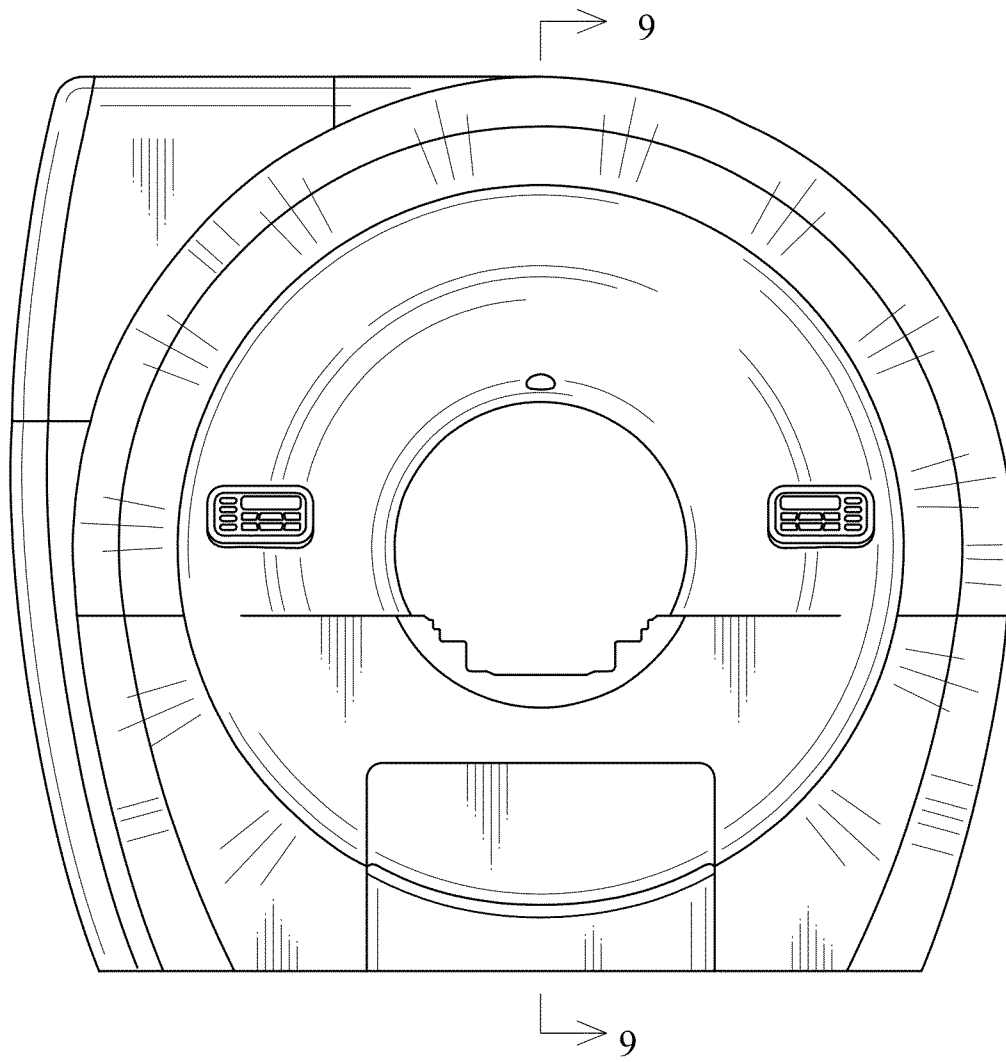

FIG. 3

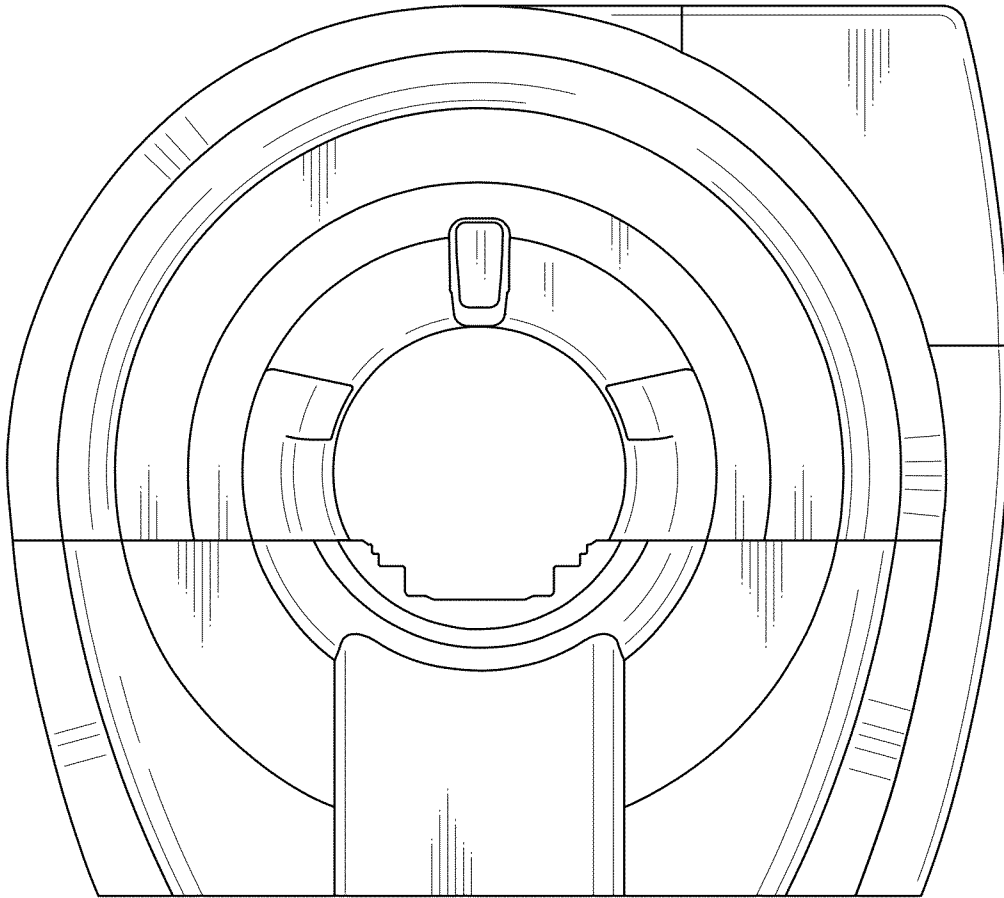

FIG. 4

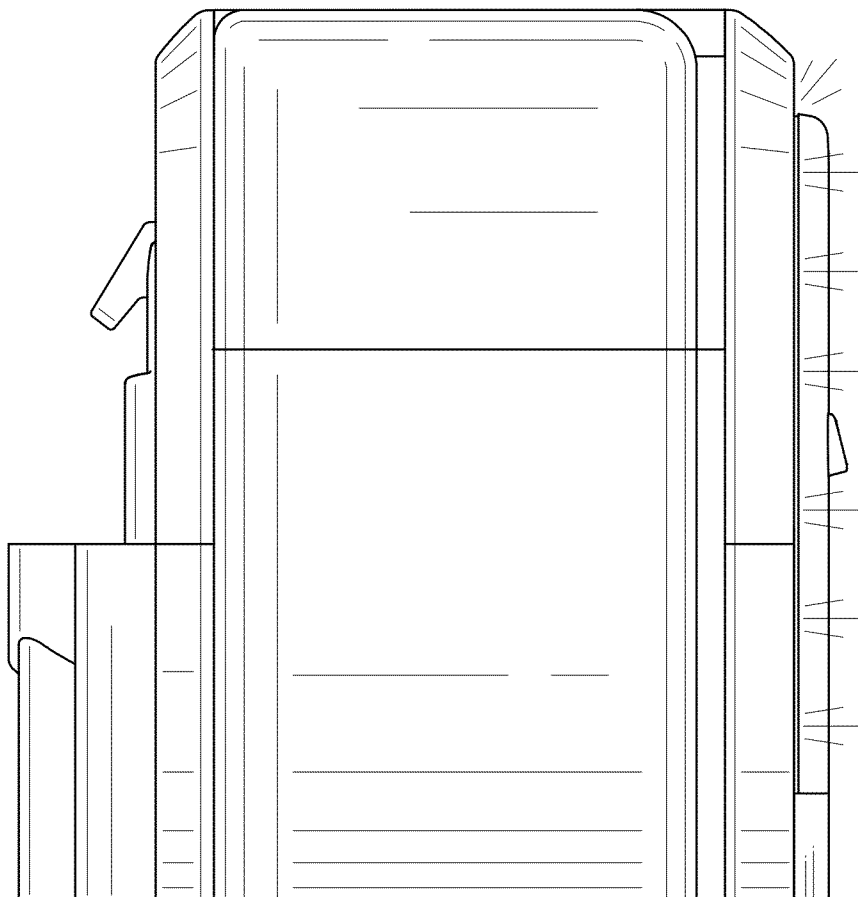

FIG. 5

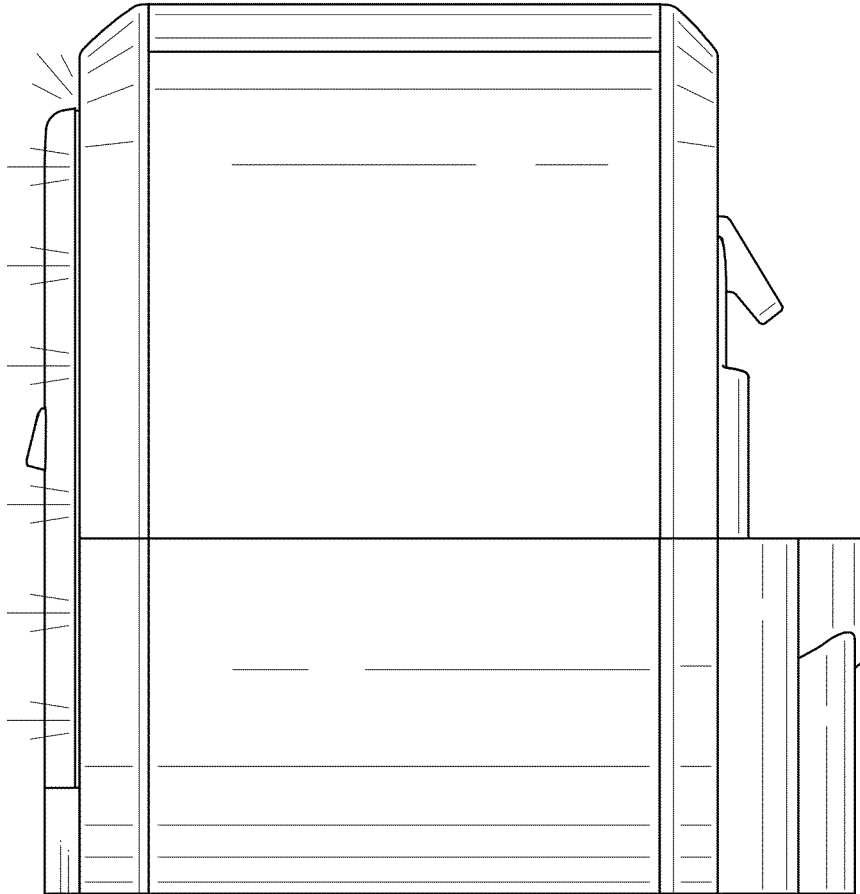

FIG. 6

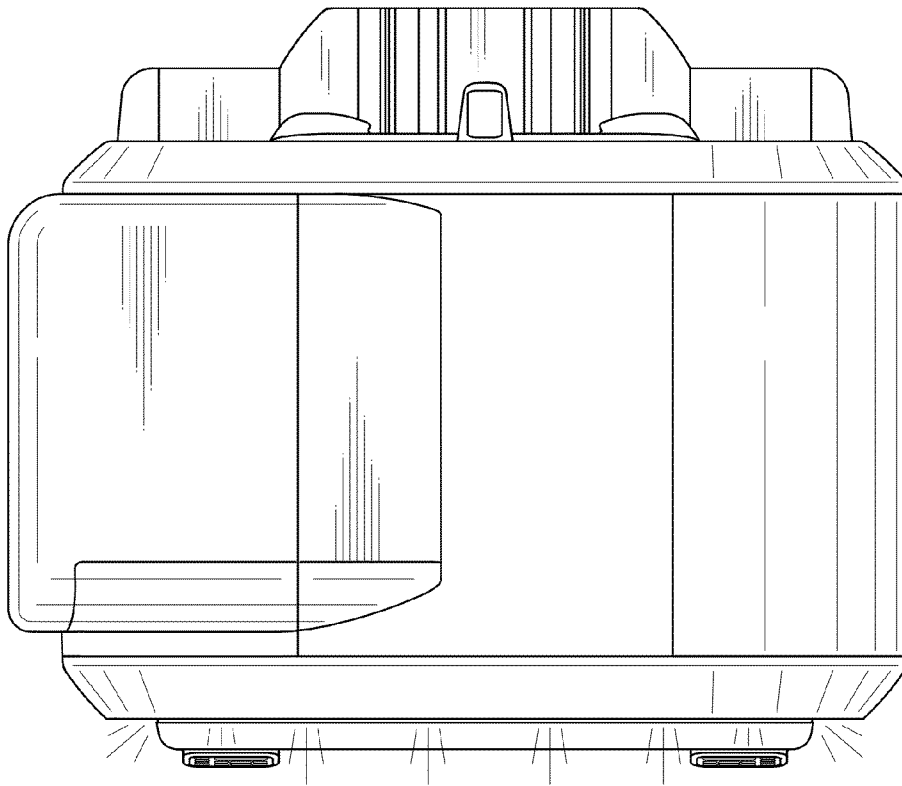

FIG. 7

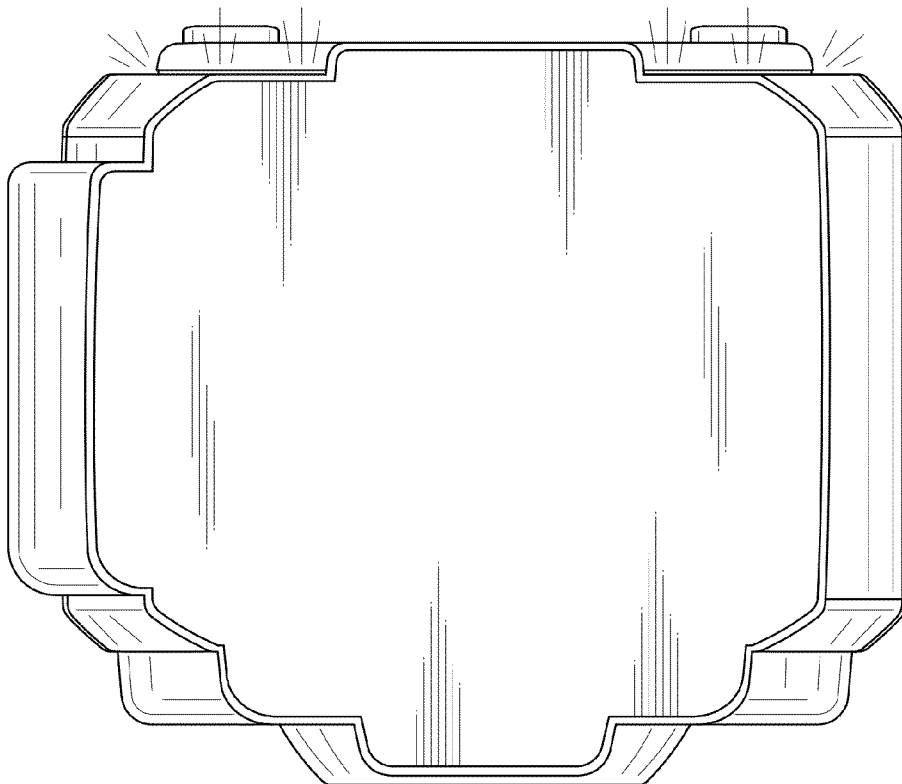

FIG. 8

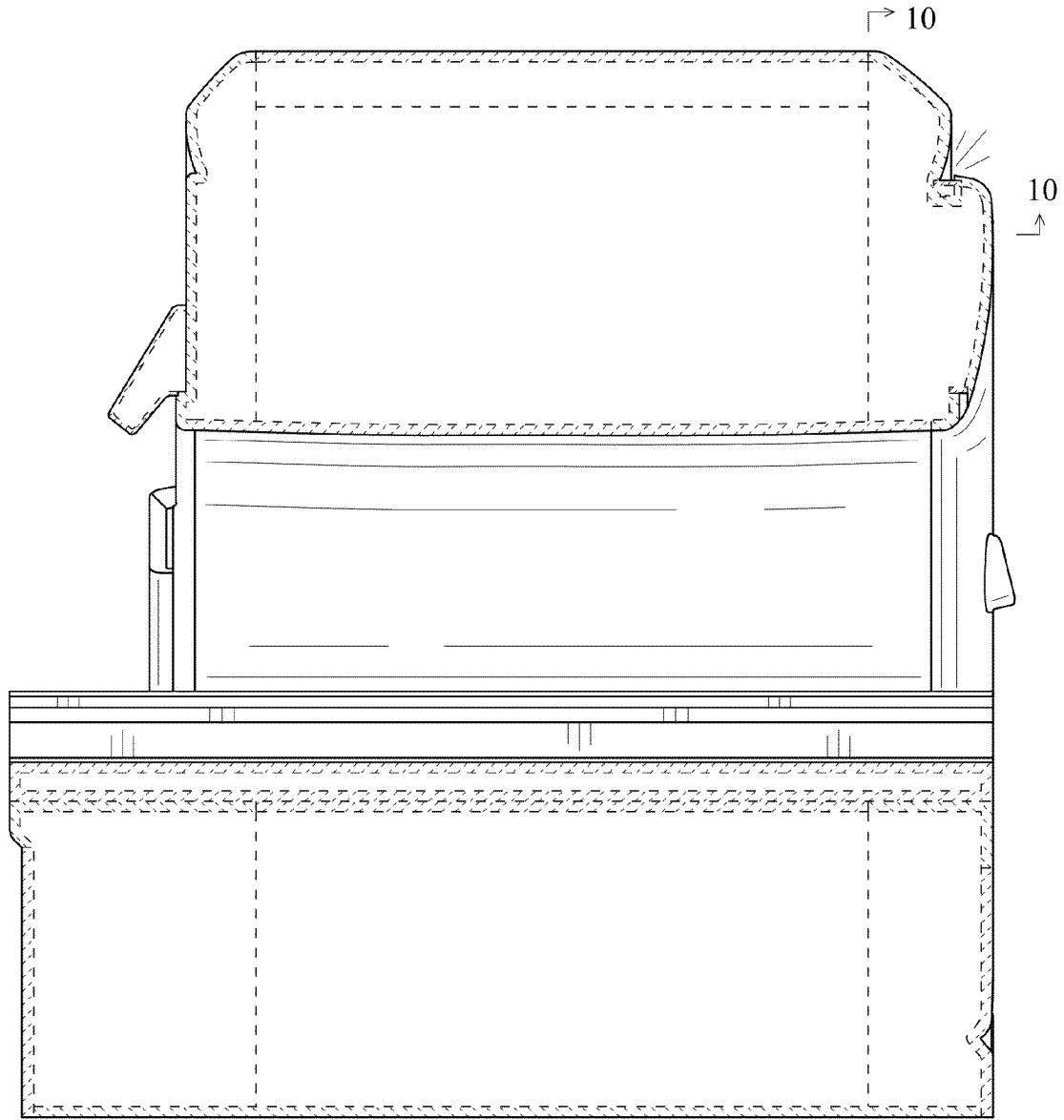

FIG. 9

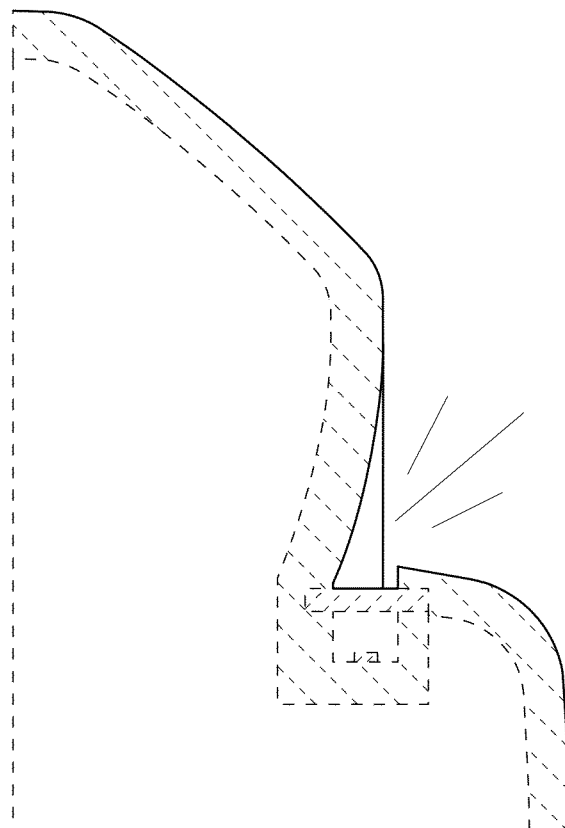

FIG. 10