



US 20090081611A1

(19) **United States**
(12) **Patent Application Publication**
Hines et al.

(10) **Pub. No.: US 2009/0081611 A1**
(43) **Pub. Date: Mar. 26, 2009**

(54) **METHODS, DEVICES, SYSTEMS,
ASSEMBLIES, AND KITS FOR TISSUE
RETRACTION IN AN ORAL CAVITY**

filed on Feb. 7, 2008, provisional application No. 61/081,908, filed on Jul. 18, 2008.

(75) Inventors: **Craig Hines**, San Francisco, CA (US); **Curtis Pontynen**, San Jose, CA (US)

Publication Classification

(51) **Int. Cl.**
A61C 3/00 (2006.01)
(52) **U.S. Cl.** **433/140; 433/215**

Correspondence Address:
WILSON SONSINI GOODRICH & ROSATI
650 PAGE MILL ROAD
PALO ALTO, CA 94304-1050 (US)

(57) **ABSTRACT**

Provided herein is a retraction device for retracting soft tissue from the dental surfaces in the oral cavity of a patient. The retraction device is comprised of a topology conformable structure, where the topology conformable structure is adaptable to be delivered to the oral cavity in a constrained shape. The device can then undergo a conformation change in the oral cavity, where the device transforms into its unconstrained shape. The unconstrained shape of the device creates a useable working field in the oral cavity. The useable working field can provide increased accessibility to and/or visibility within the oral cavity. Also provided herein are methods for using the device and kits.

(73) Assignee: **InDentiv, LLC**, San Francisco, CA (US)

(21) Appl. No.: **12/239,477**

(22) Filed: **Sep. 26, 2008**

Related U.S. Application Data

(60) Provisional application No. 60/975,387, filed on Sep. 26, 2007, provisional application No. 61/026,989,

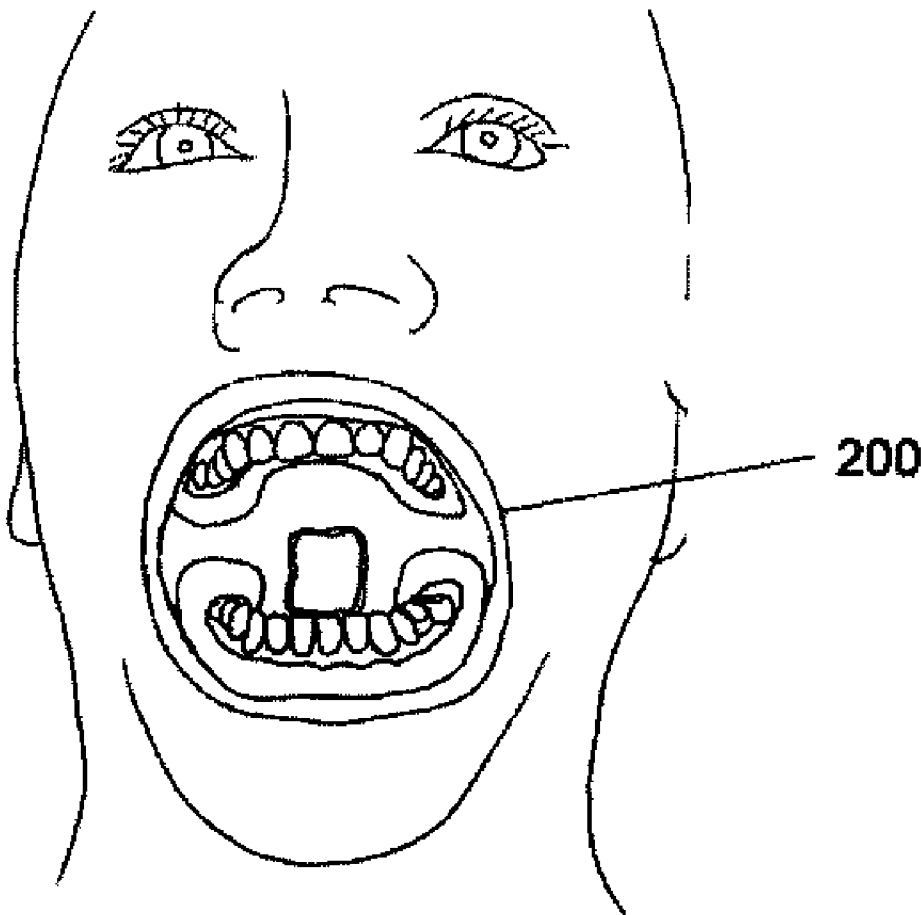

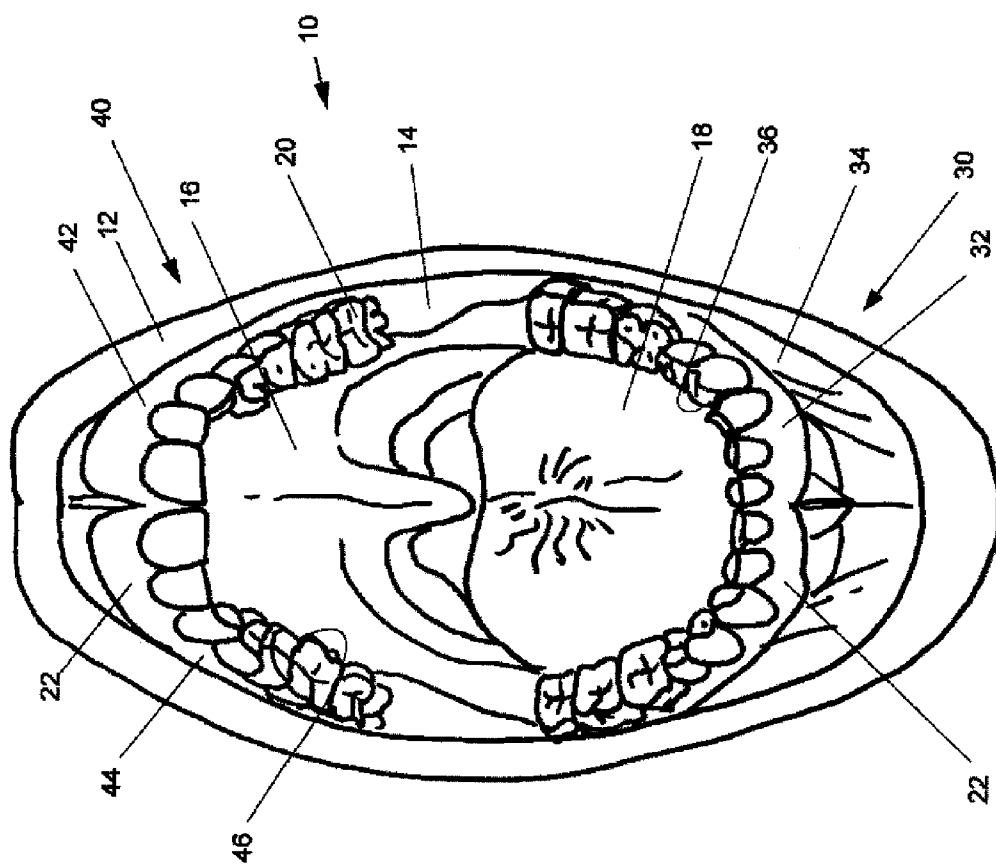

Fig1A

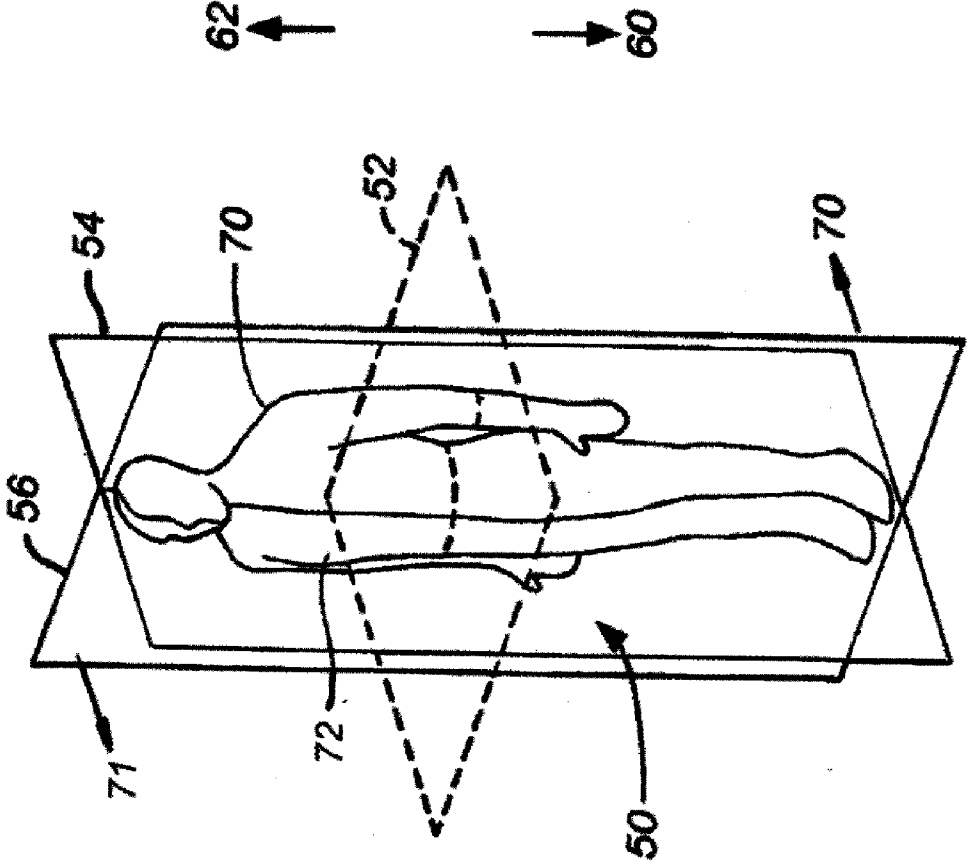

Fig 1B

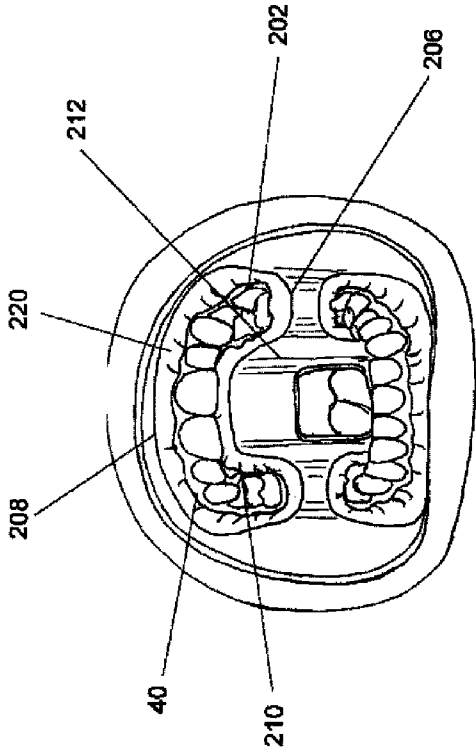

Fig 2B

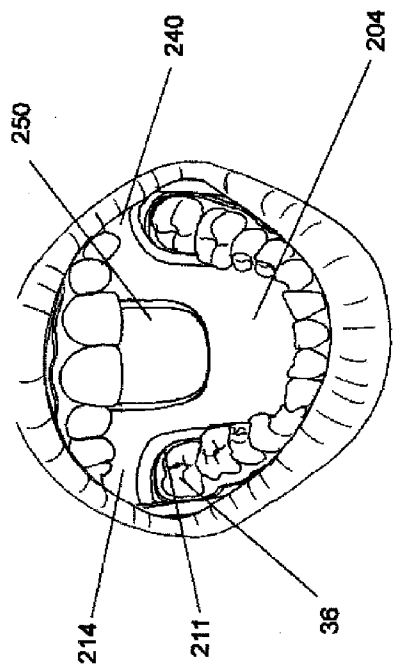

Fig 2D

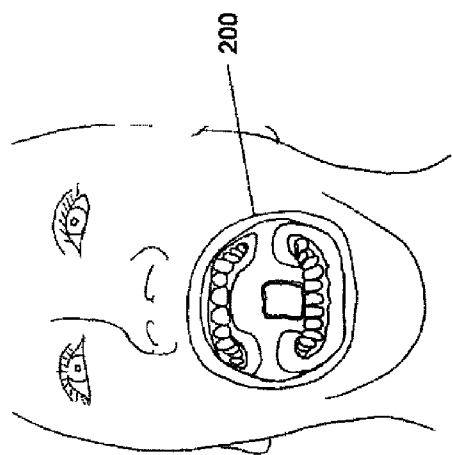

Fig 2A

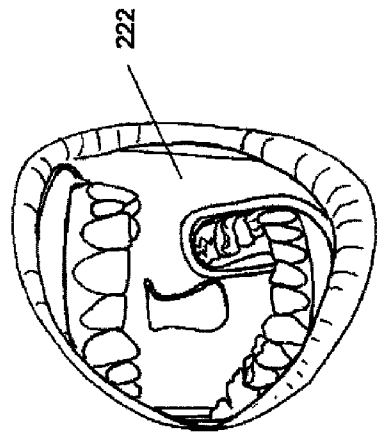

Fig 2C

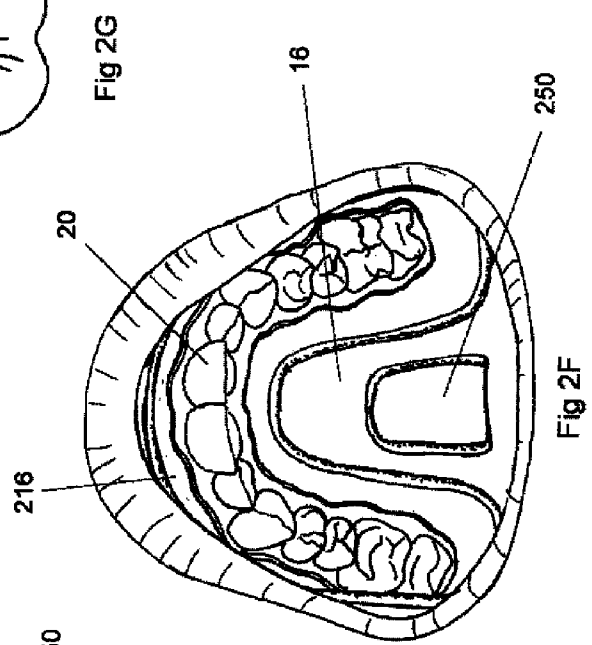
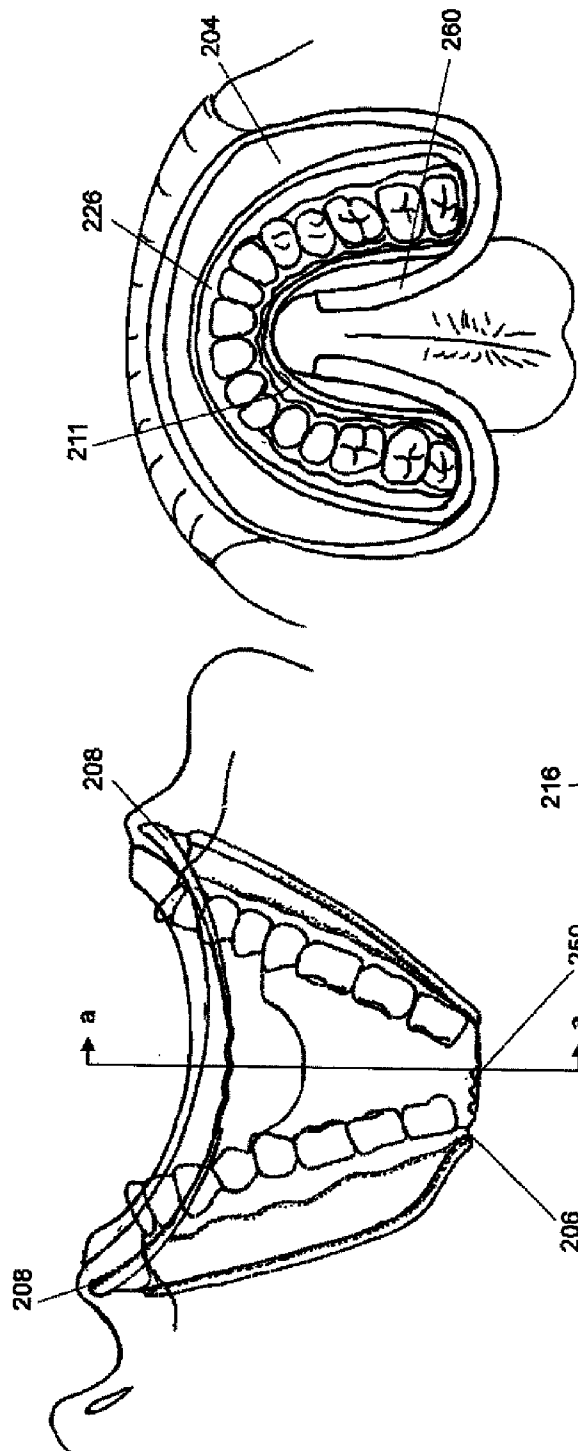

Fig 2E

Fig 2G

Fig 2F

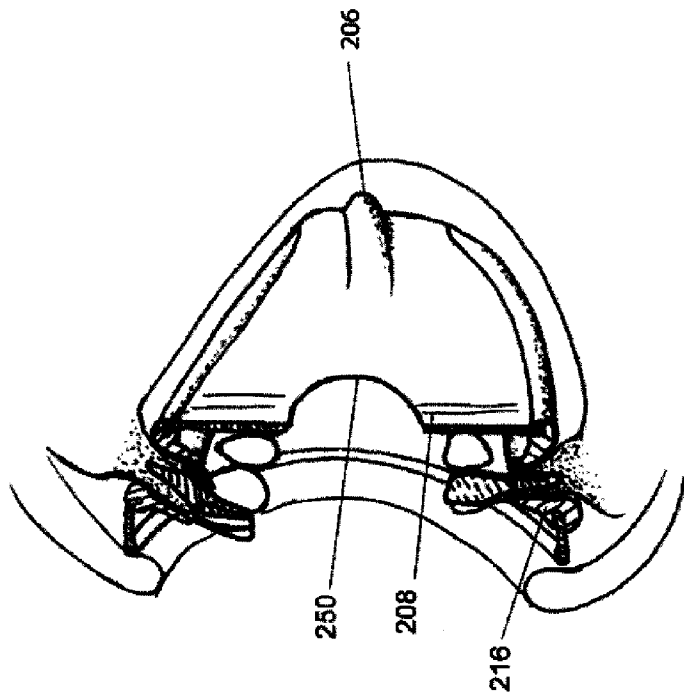

Fig 2J

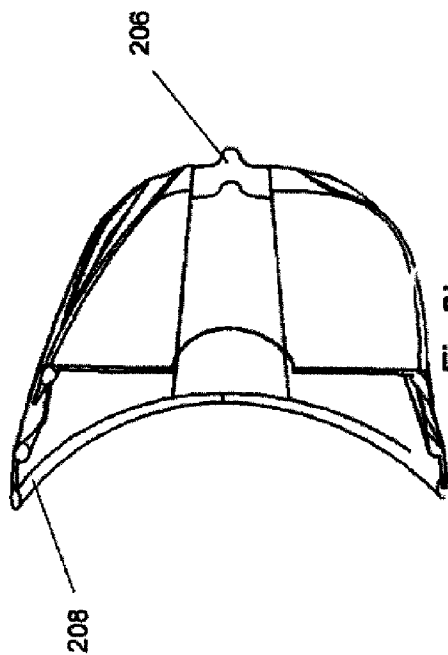

Fig 2I

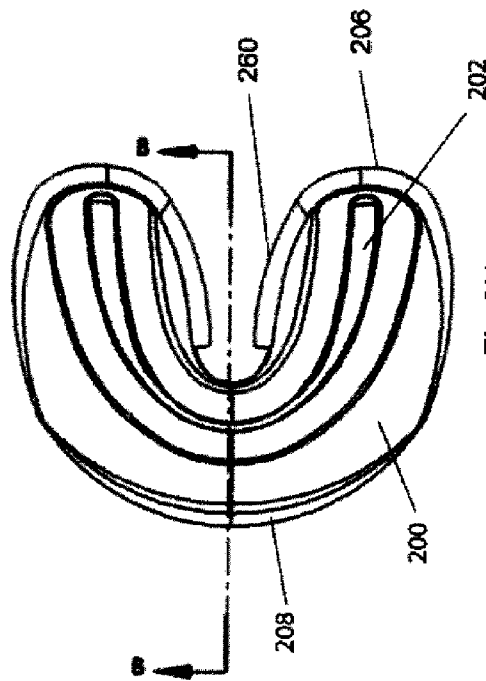

Fig 2H

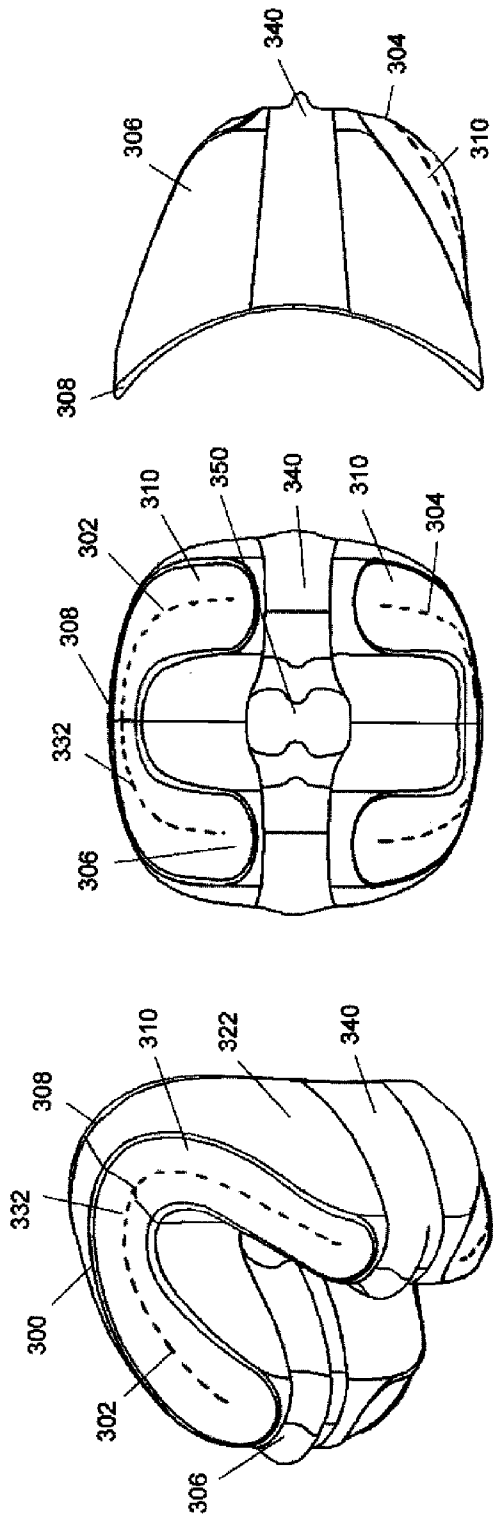

Fig 3C

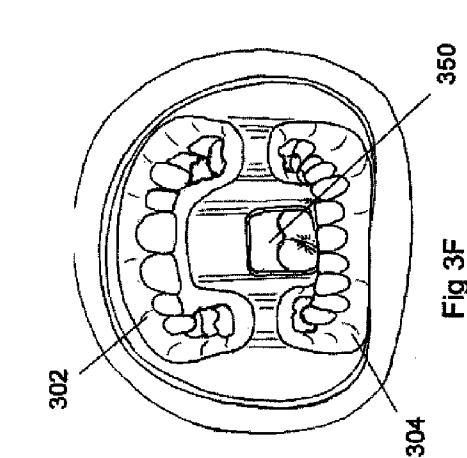

Fig 3B

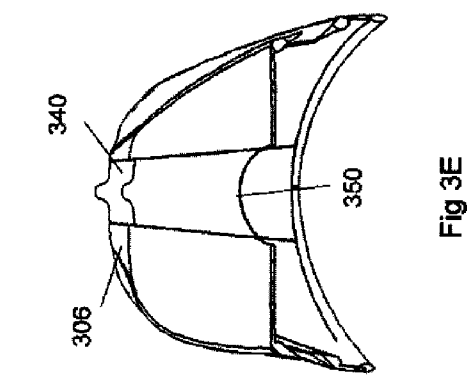

Fig 3A

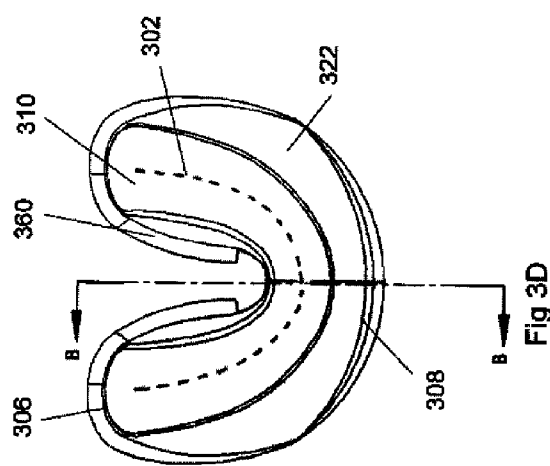
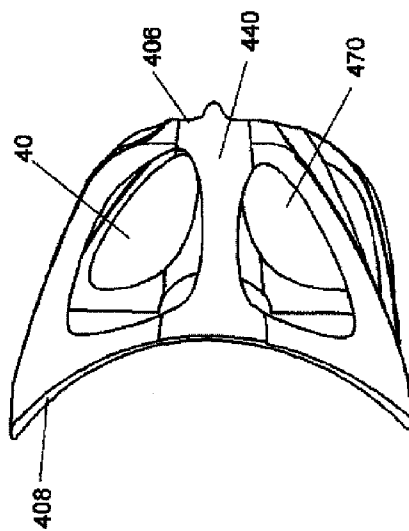
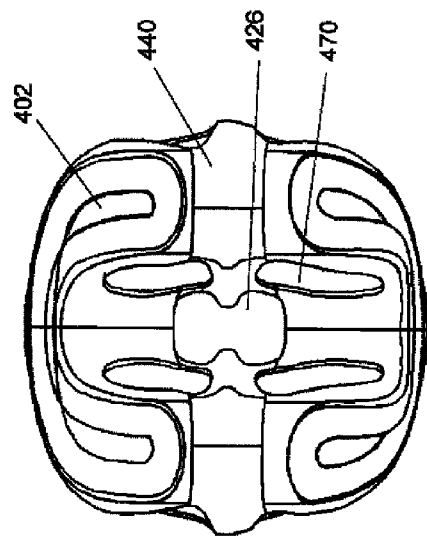
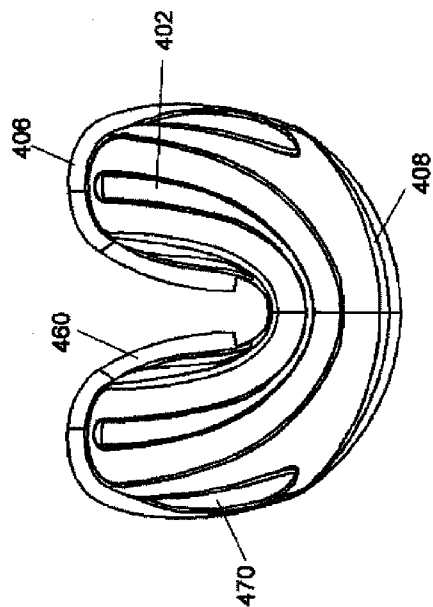
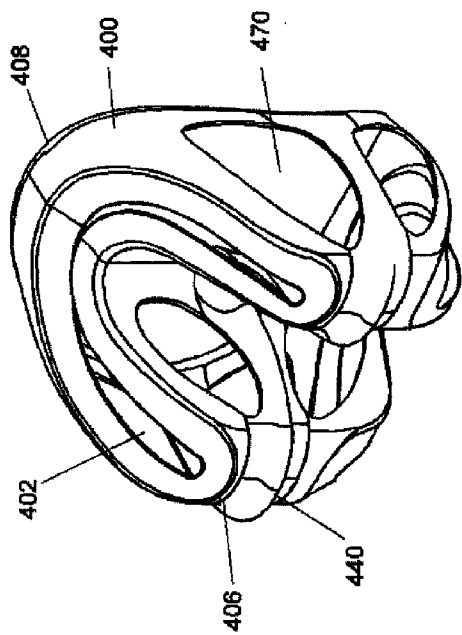
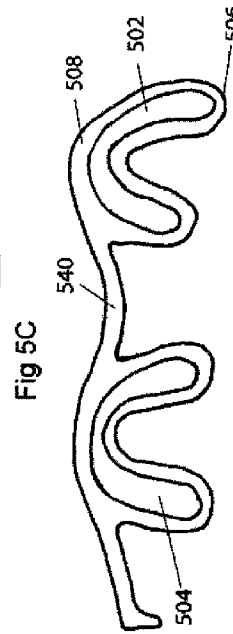
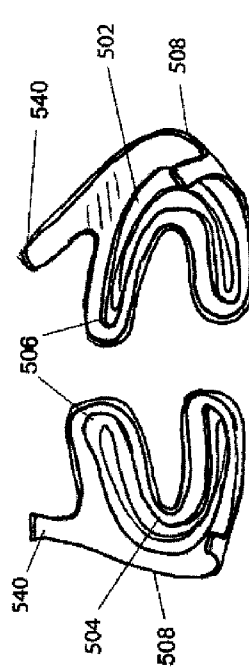
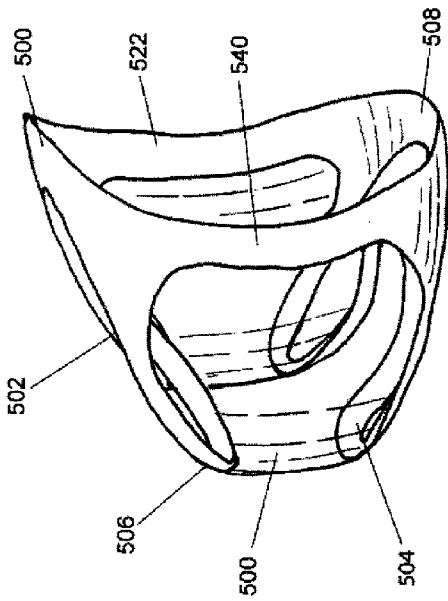
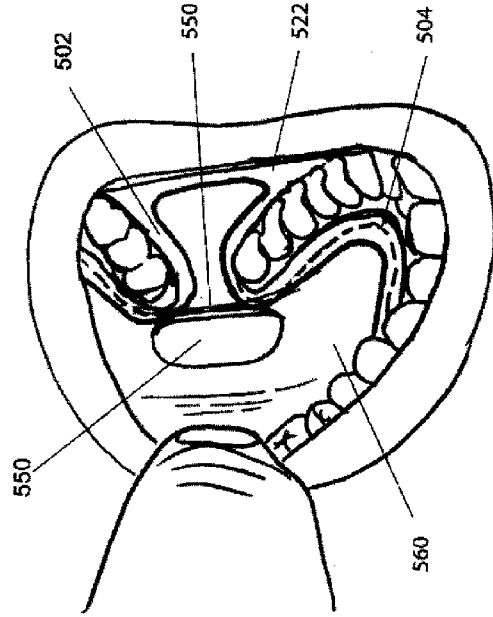
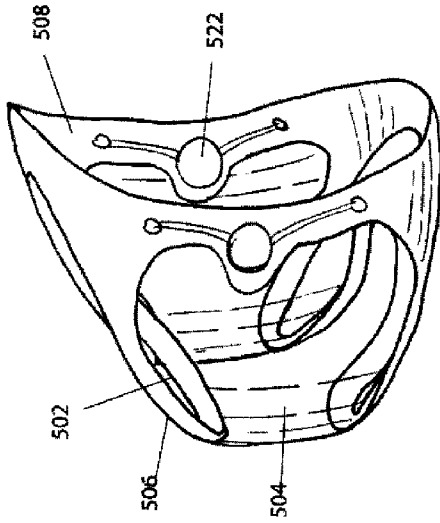

Fig 3D





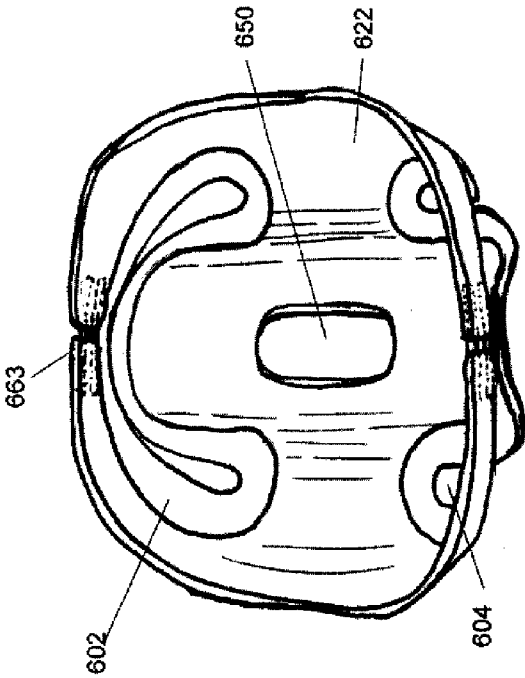

Fig 6B

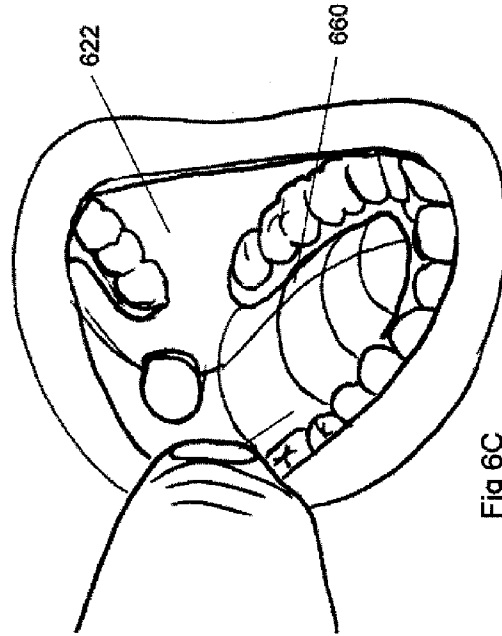

Fig 6C

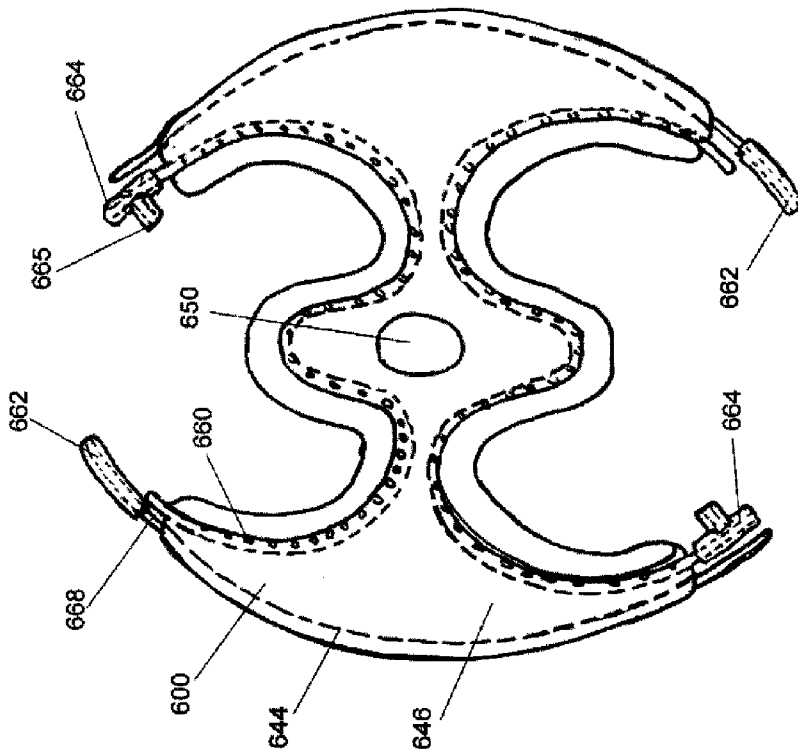

Fig 6A

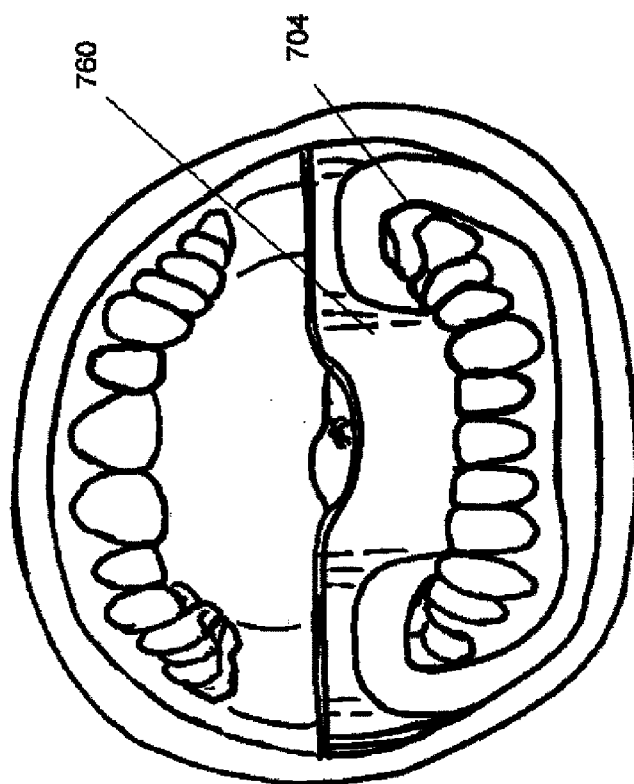

Fig 7B

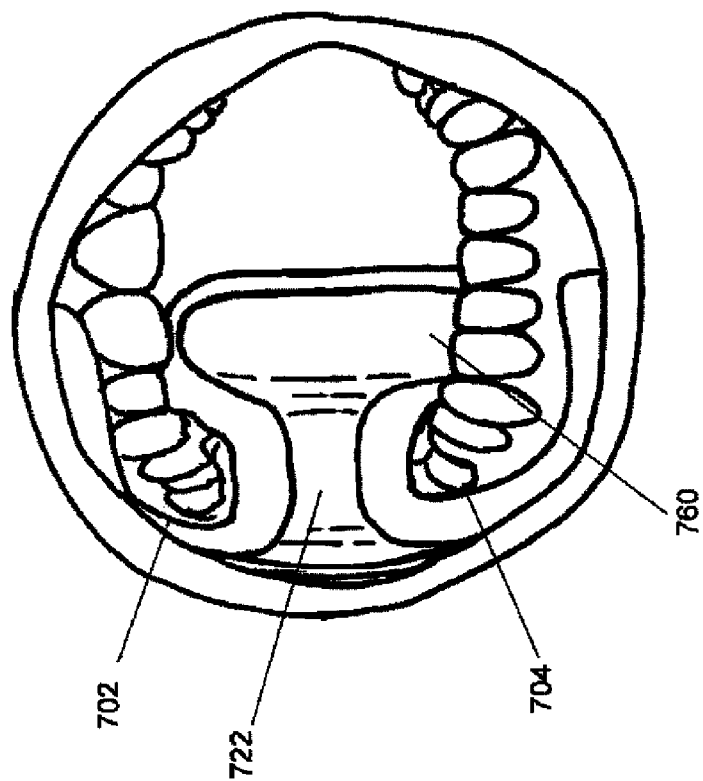

Fig 7A

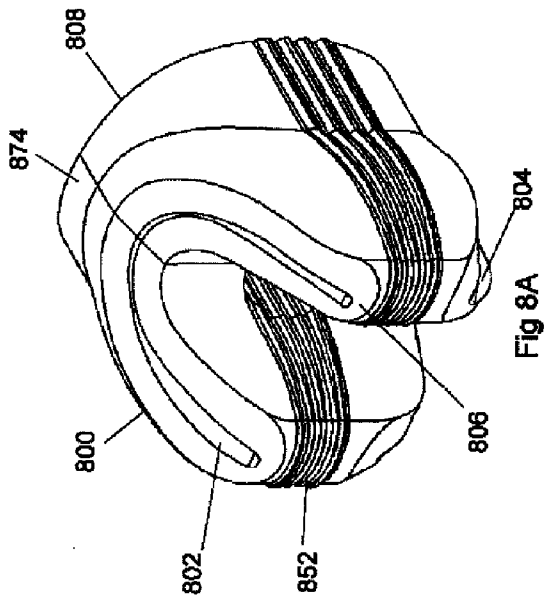

Fig 8A

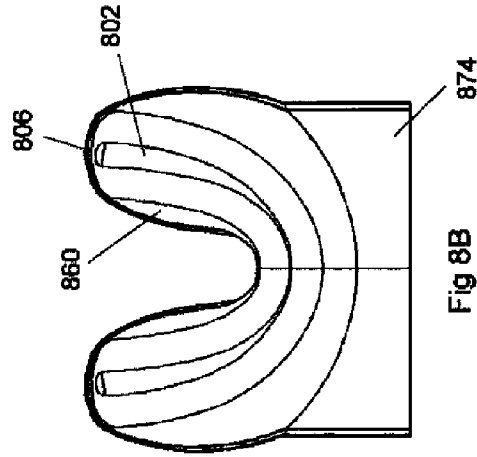

Fig 8B

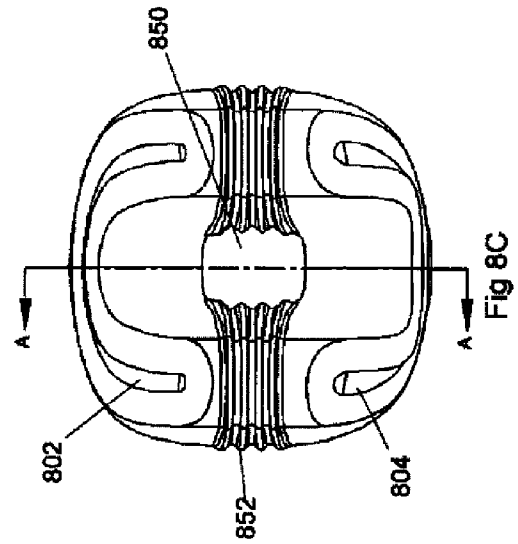

Fig 8C

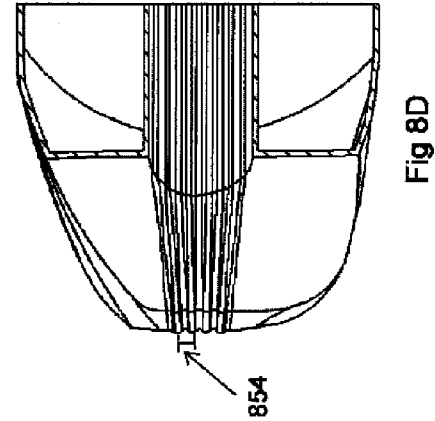

Fig 8D

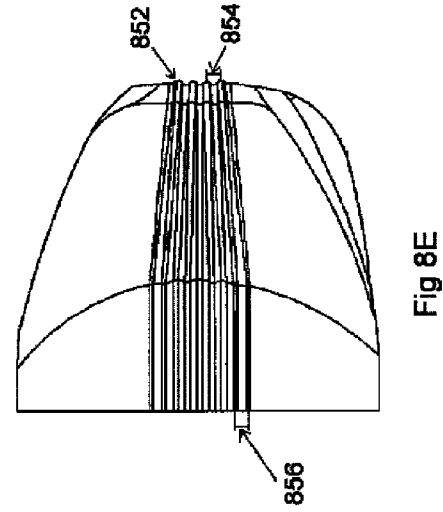

Fig 8E

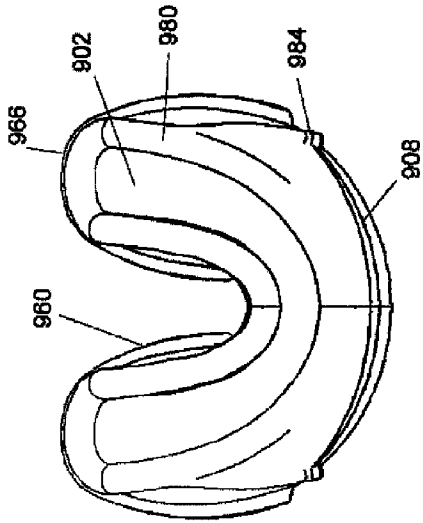
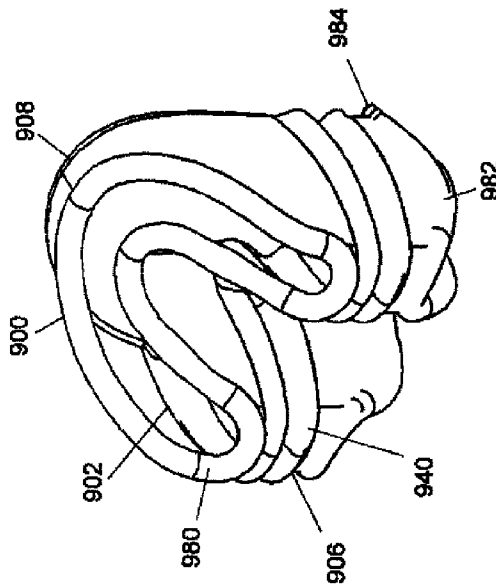

Fig 9B

Fig 9A

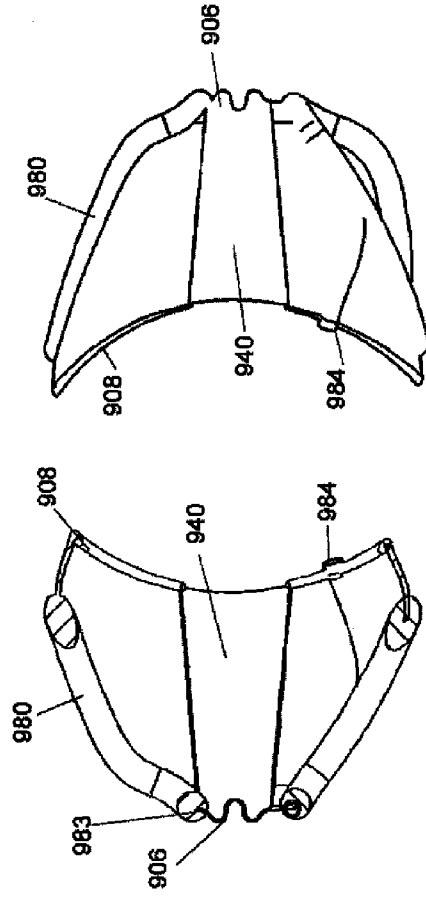
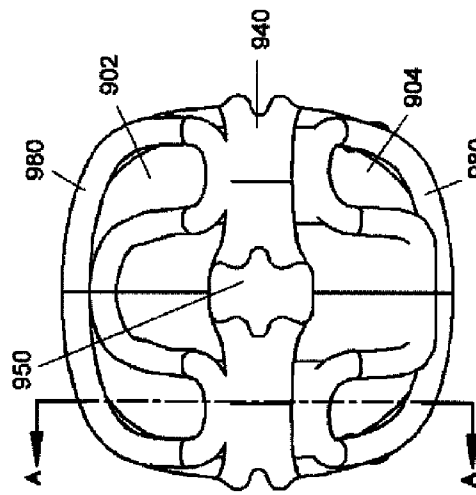
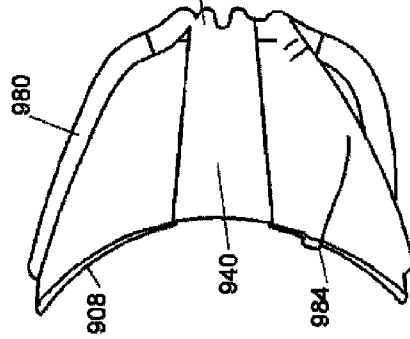

Fig 9C

Fig 9D

Fig 9E



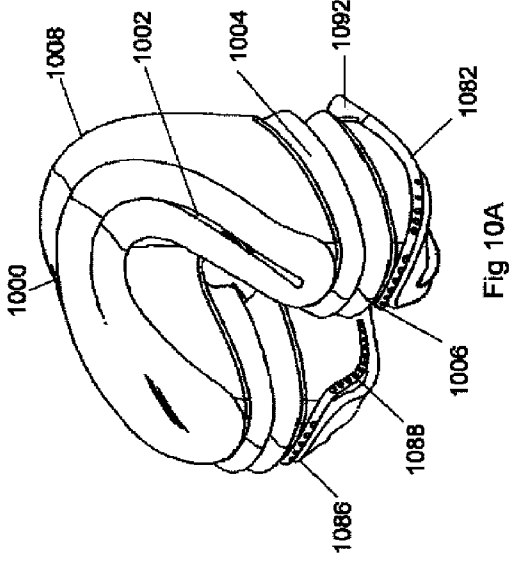

Fig 10A

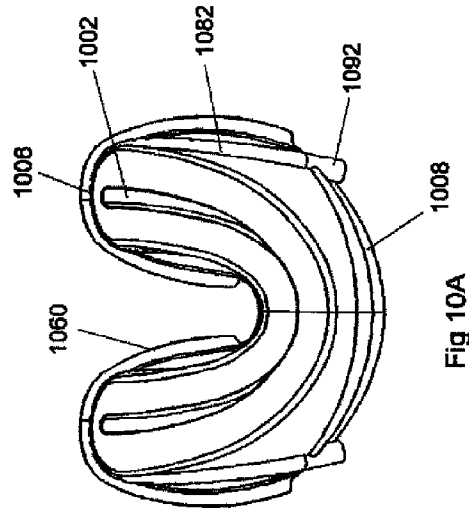

Fig 10A

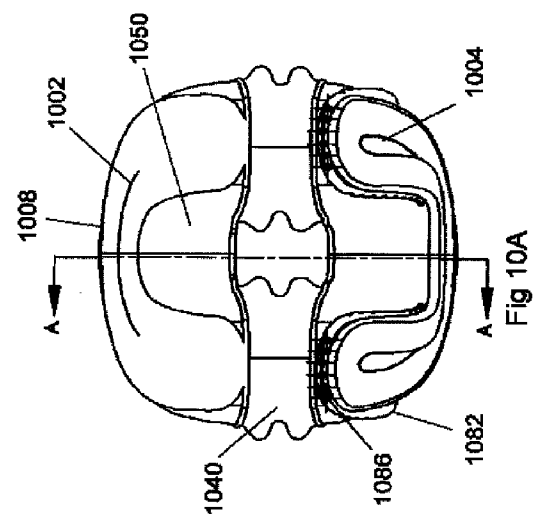

Fig 10A

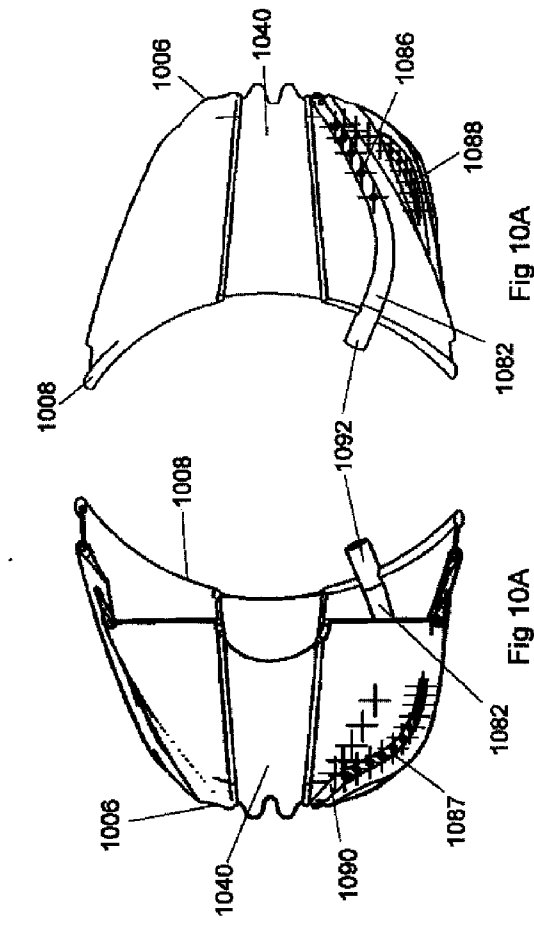

Fig 10A

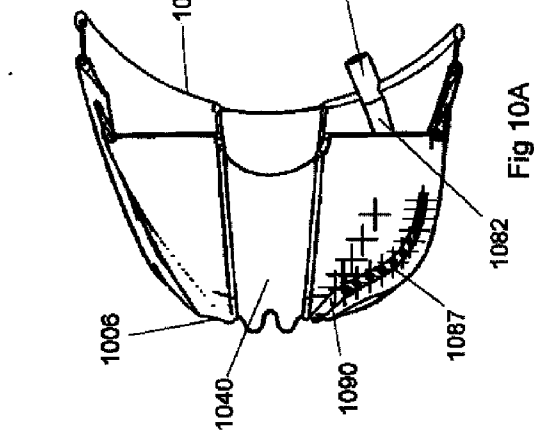

Fig 10A

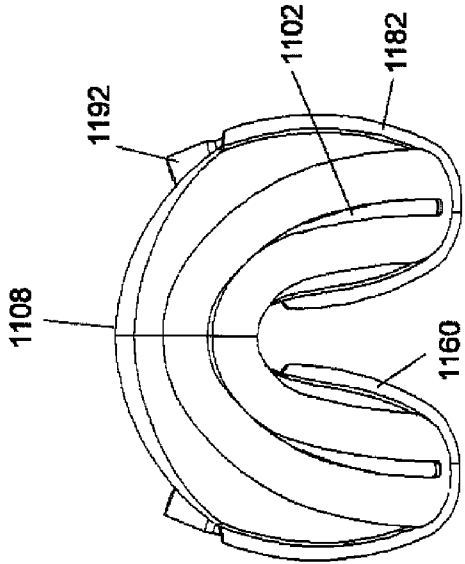

Fig 11B

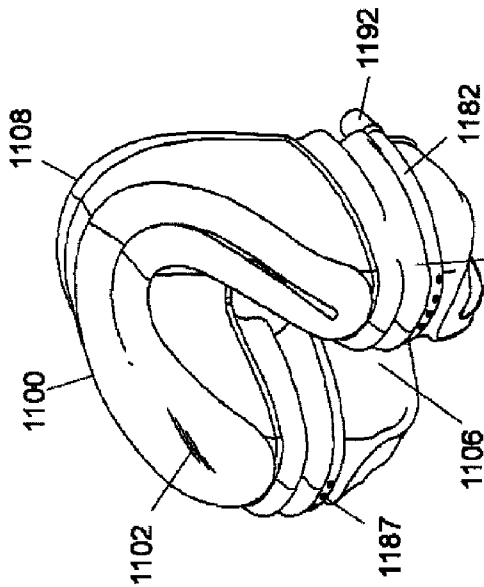

Fig 11A

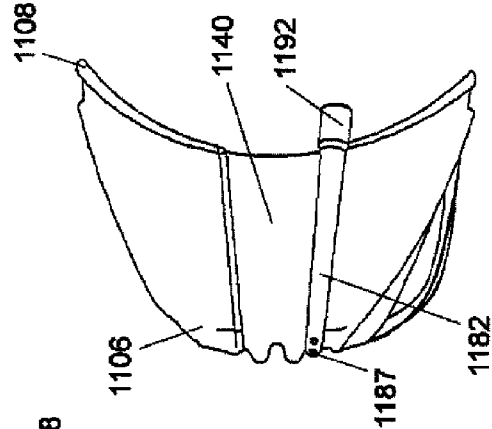

Fig 11E

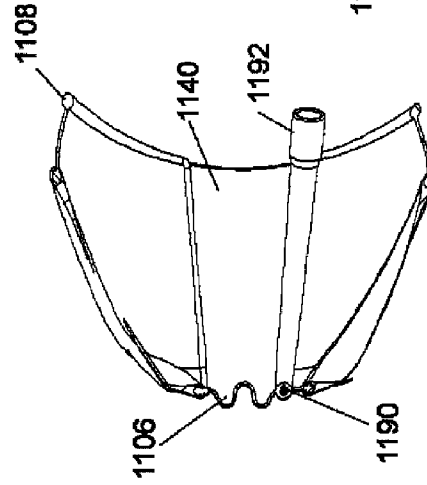

Fig 11D

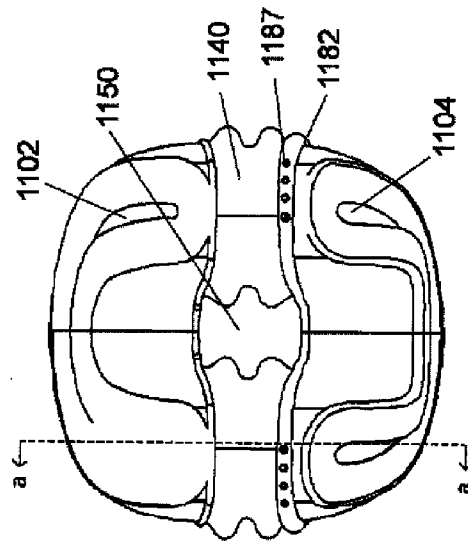

Fig 11C

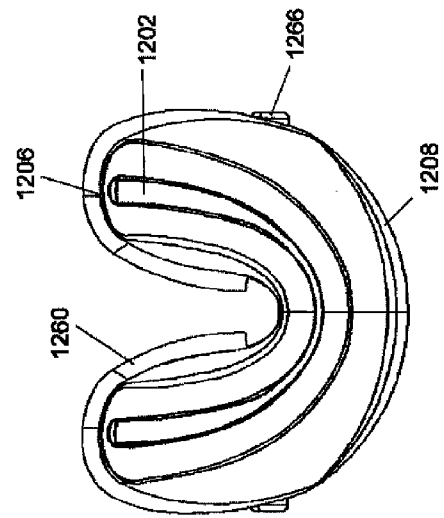
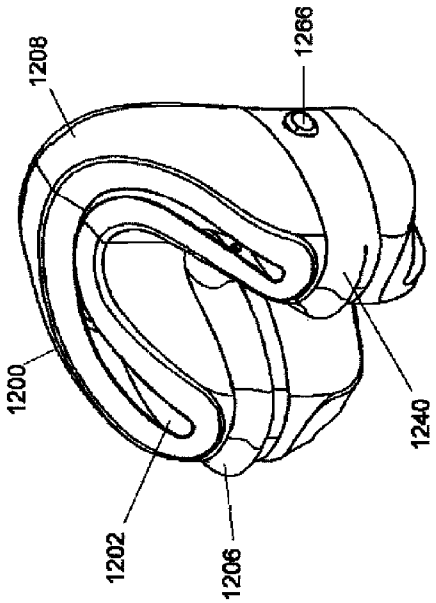

Fig 12A

Fig 12B

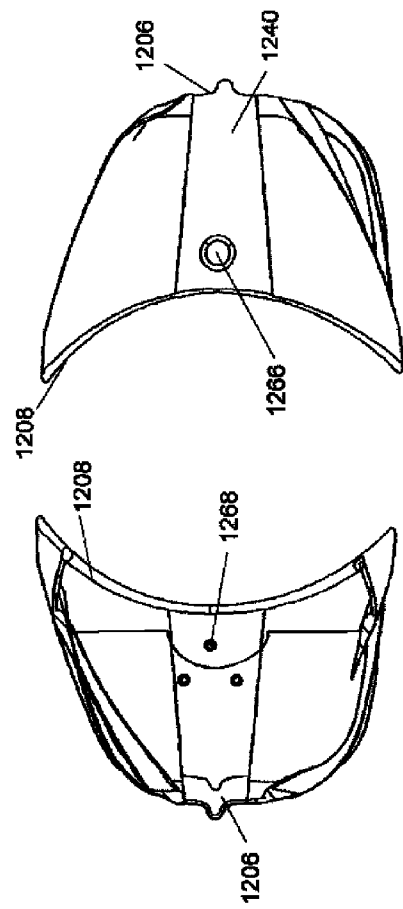
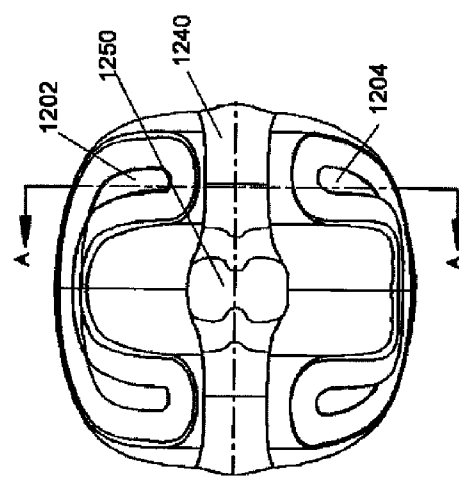

Fig 12D

Fig 12E

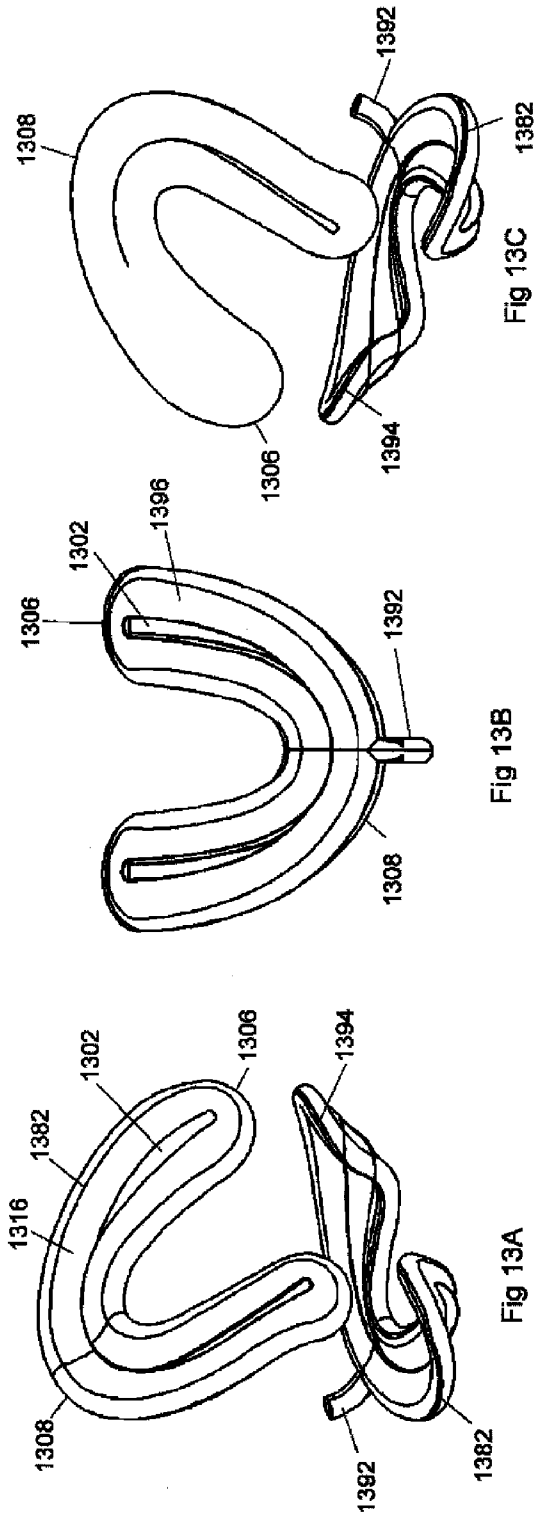

Fig 13B

Fig 13C

Fig 13A

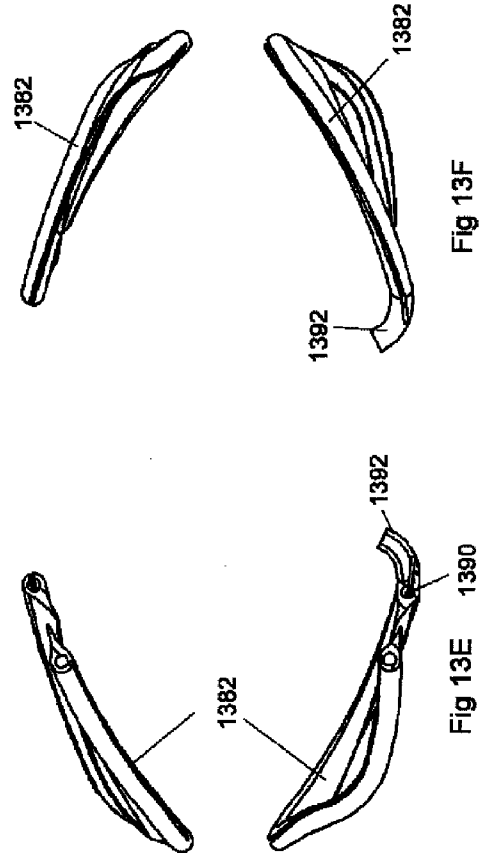

Fig 13E

Fig 13F

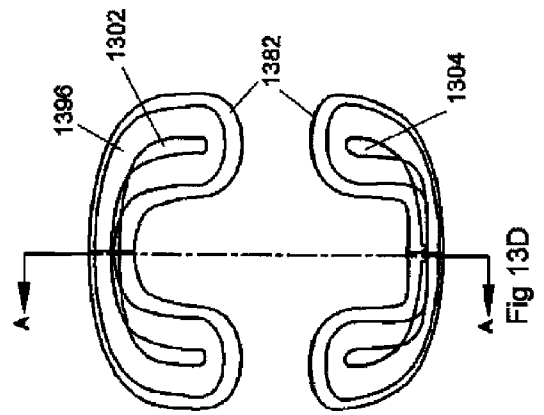

Fig 13D

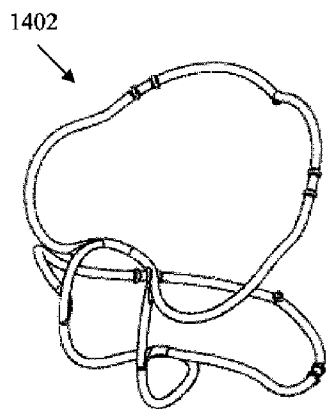

FIG. 14A

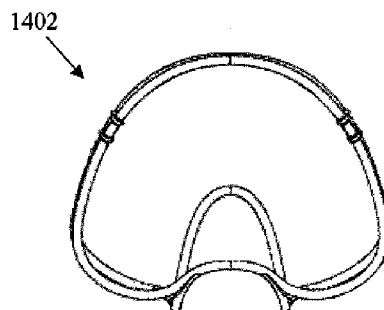

FIG. 14B

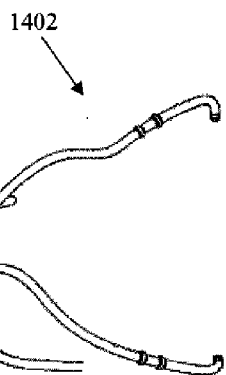

FIG. 14C

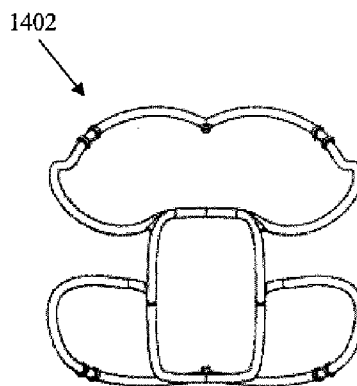
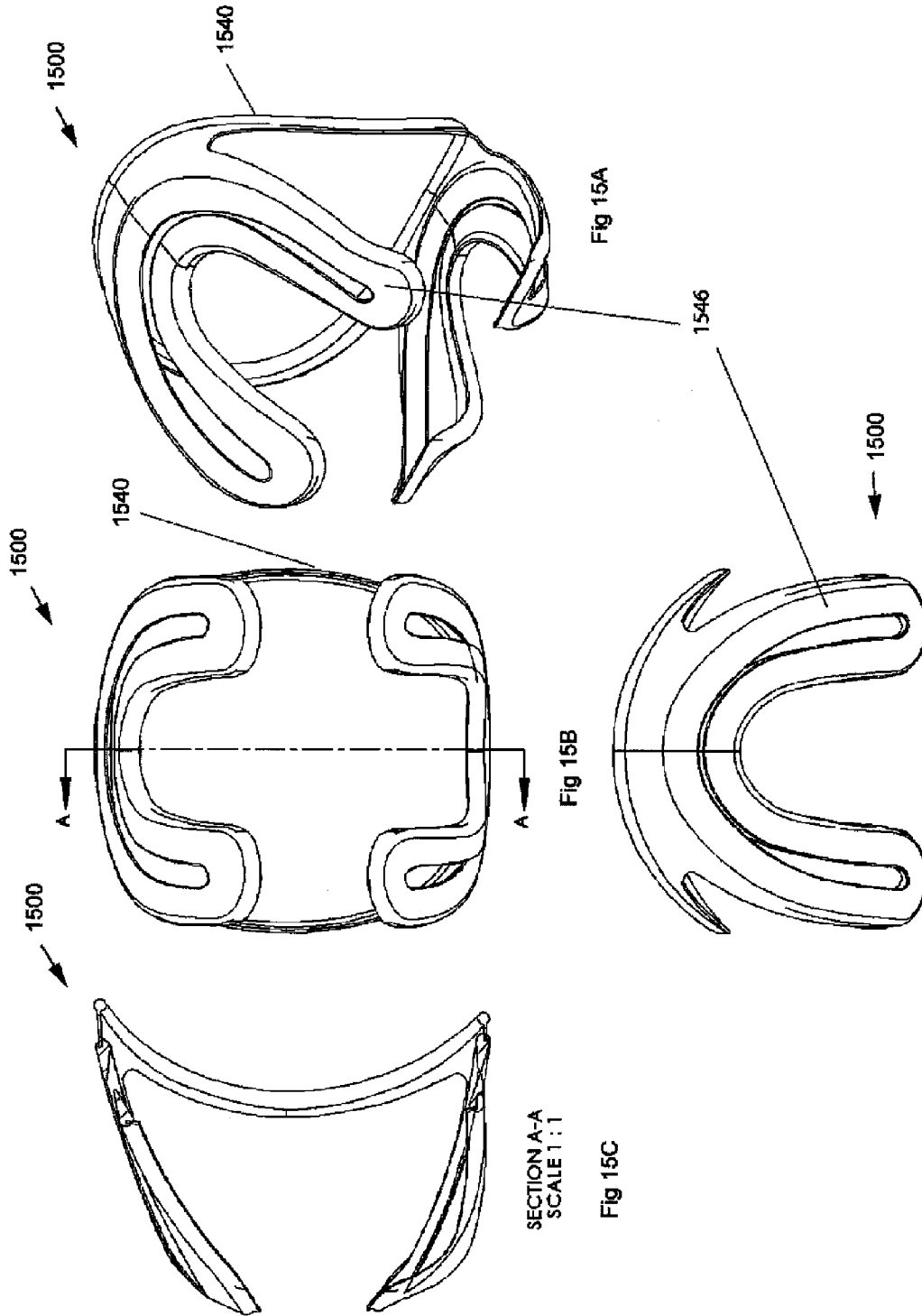

FIG. 14D



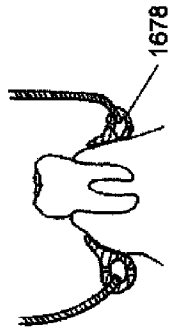

Fig 16F

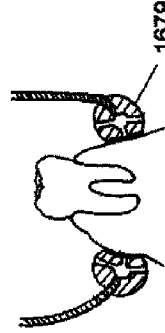

Fig 16G

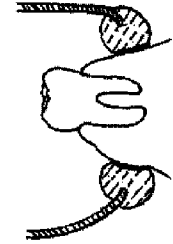

Fig 16H

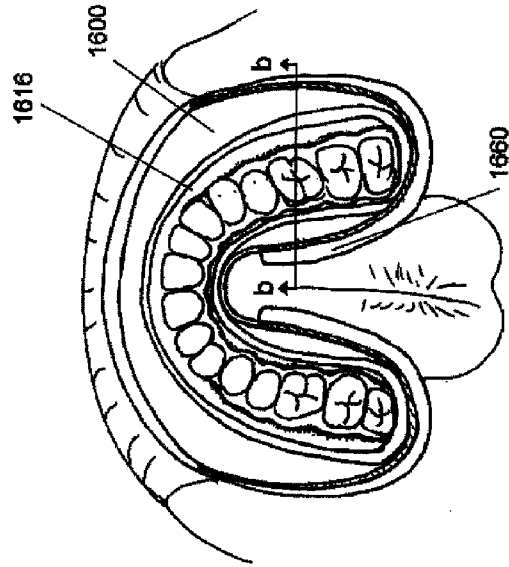

Fig 16A

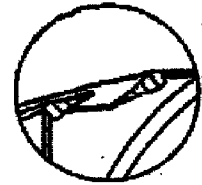

Fig 16B



Fig 16C

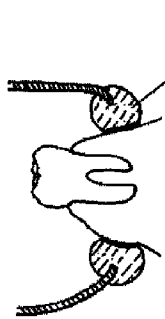

Fig 16D

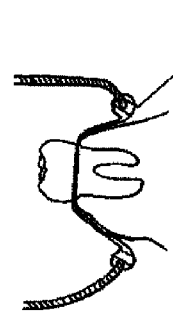

Fig 16E

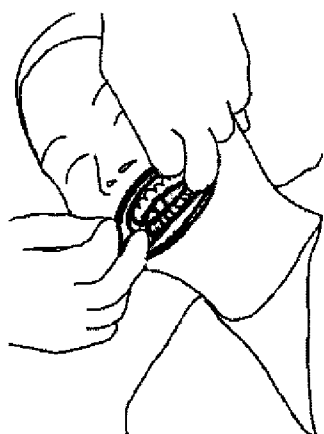

Fig 17D



Fig 17E

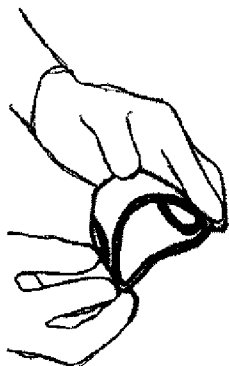

Fig 17B



Fig 17C

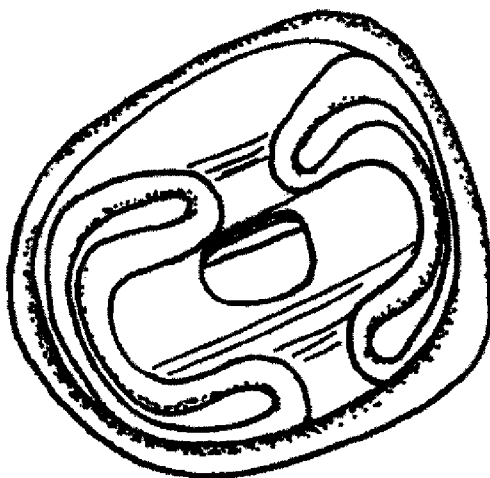

Fig 17A

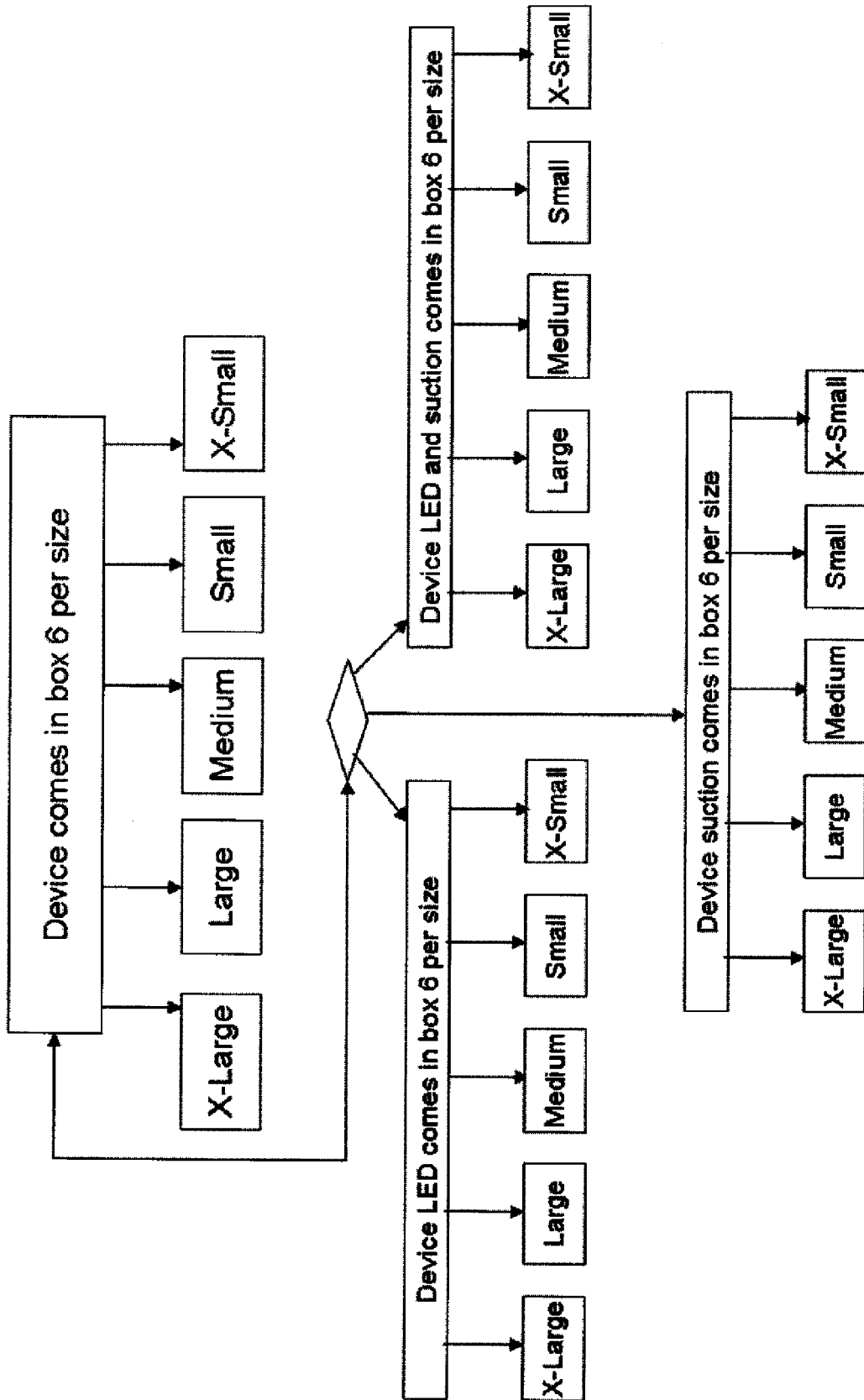

Fig 18

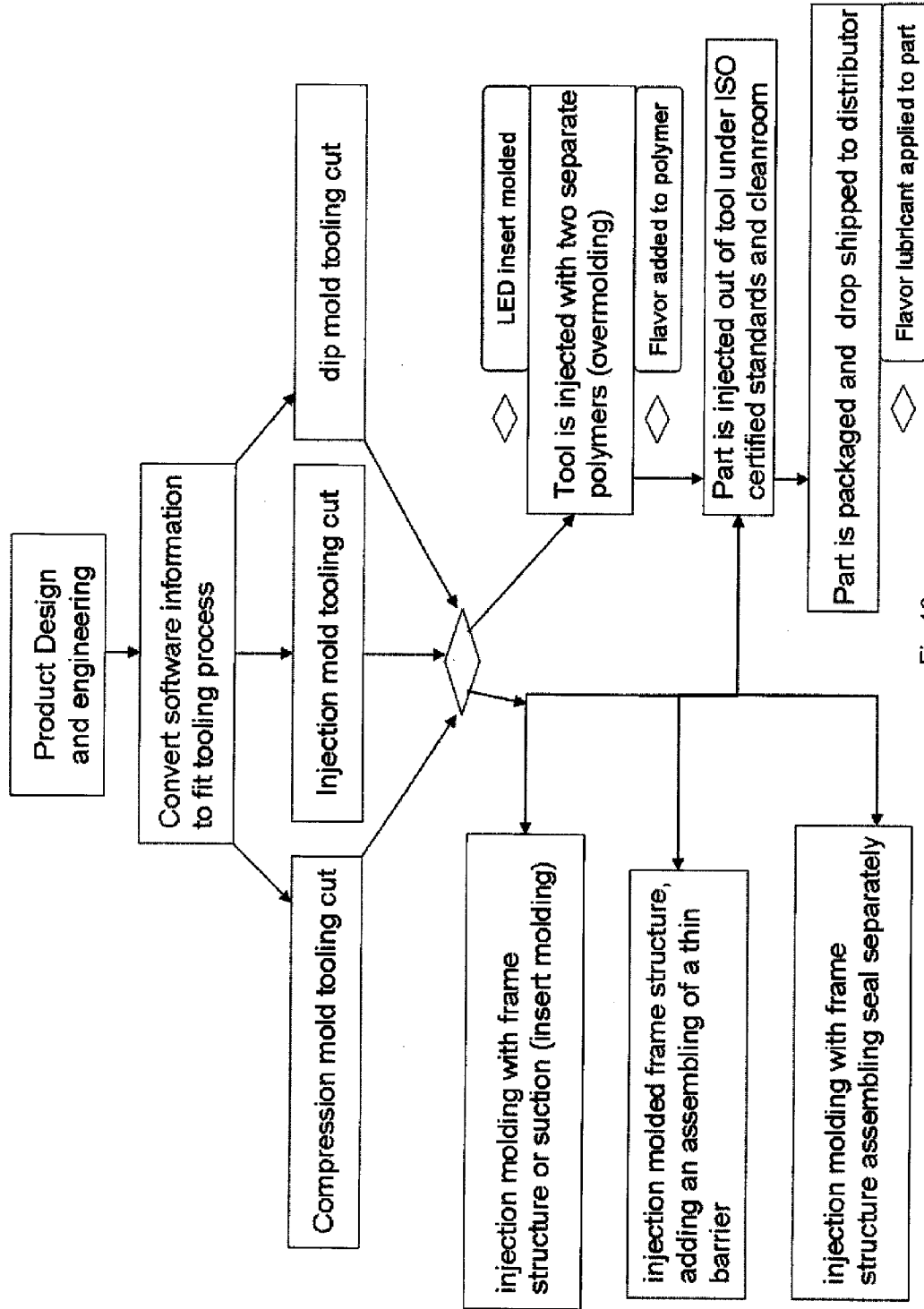

Fig 19

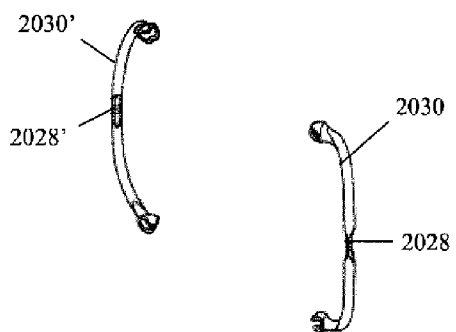

FIG. 20A



FIG. 20B

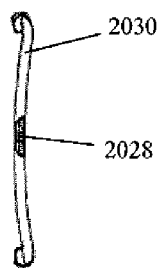

FIG. 20C

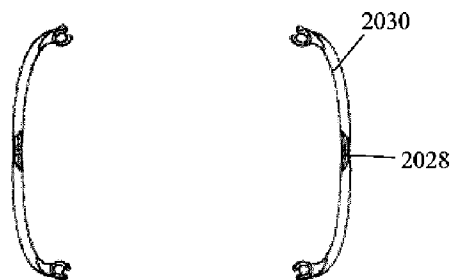

FIG. 20D

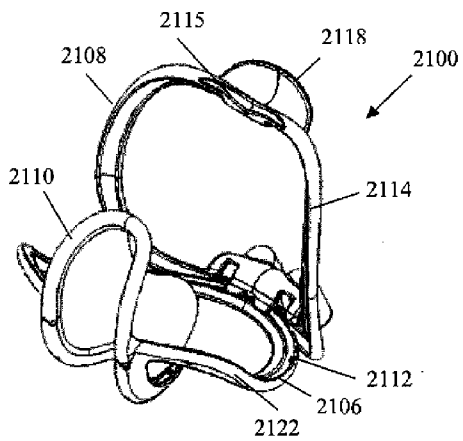

FIG. 21A

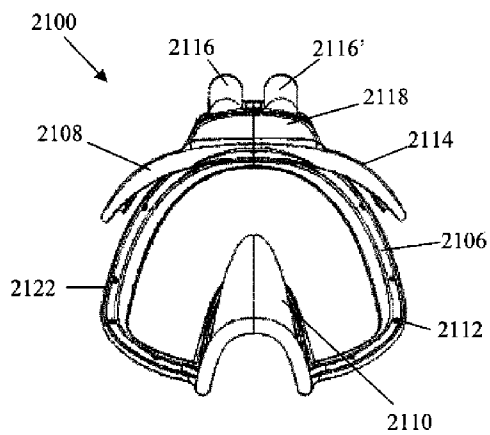

FIG. 21B

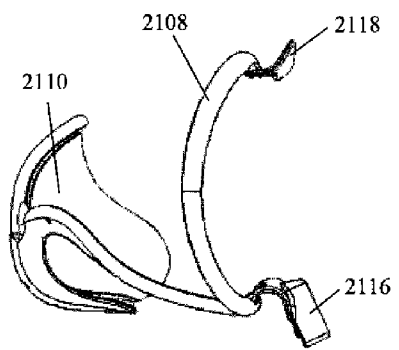

FIG. 21C

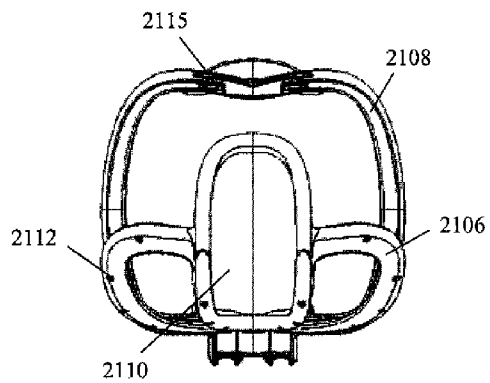

FIG. 21D

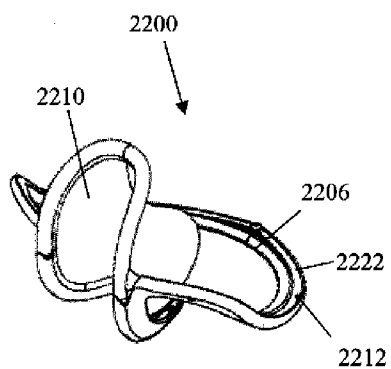

FIG. 22A

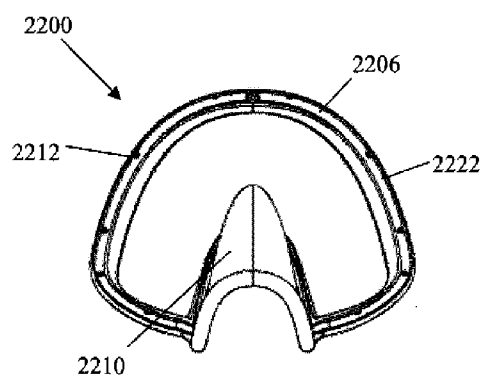

FIG. 22B

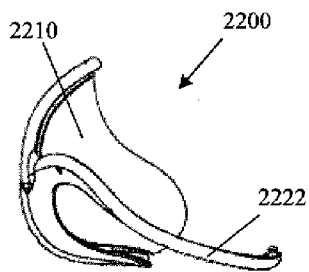

FIG. 22C

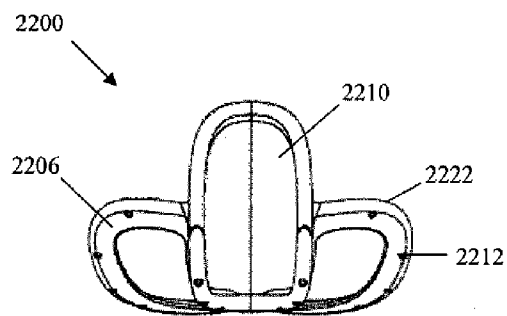

FIG. 22D

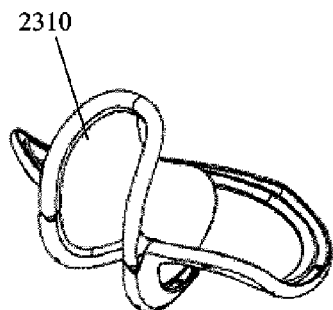

FIG. 23A

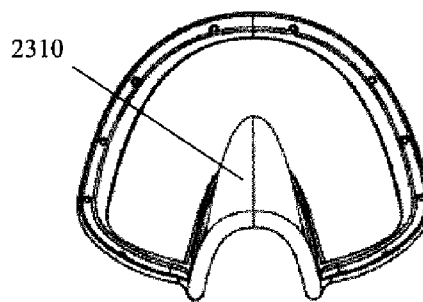

FIG. 23B

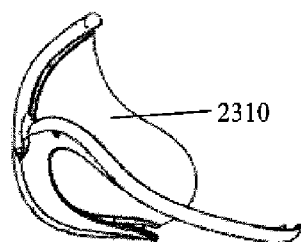

FIG. 23C

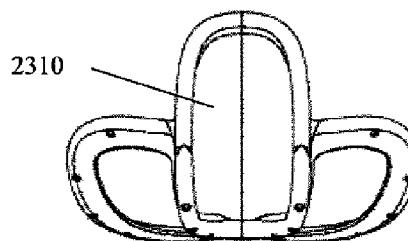

FIG. 23D

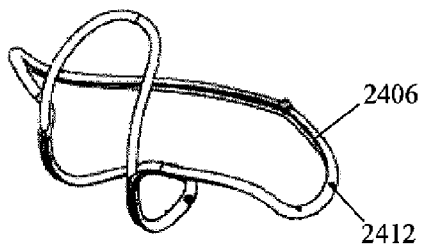

FIG. 24A

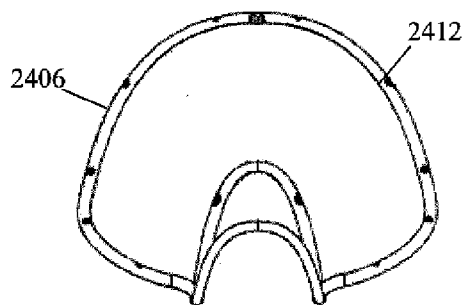

FIG. 24B

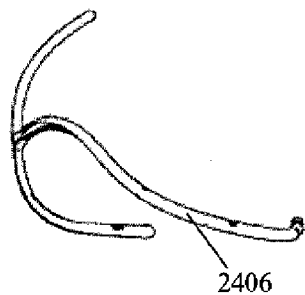

FIG. 24C

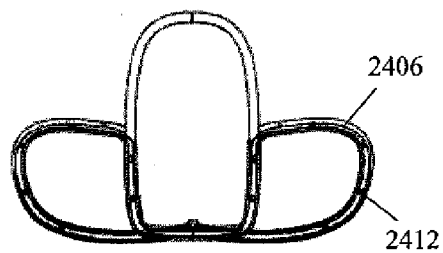

FIG. 24D

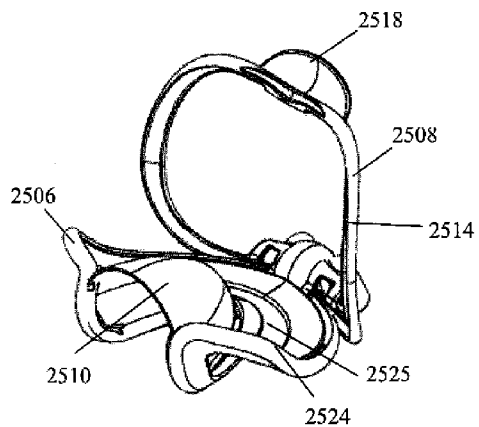

FIG. 25A

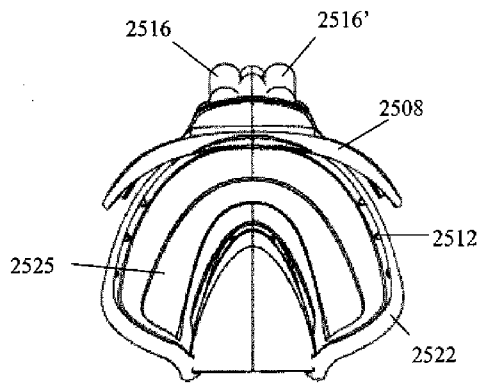

FIG. 25B

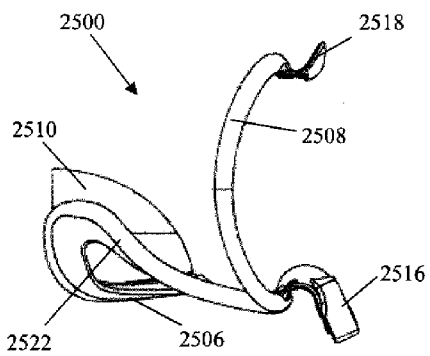

FIG. 25C

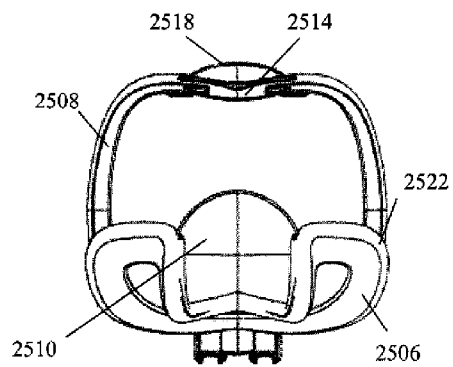

FIG. 25D

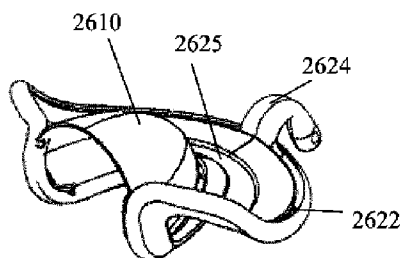

FIG. 26A

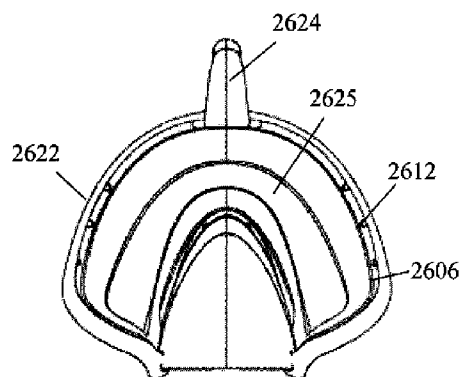

FIG. 26B

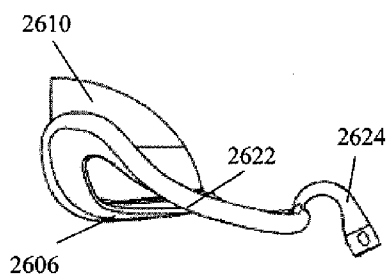

FIG. 26C

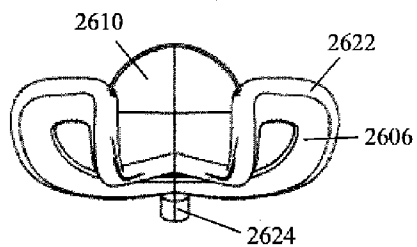

FIG. 26D

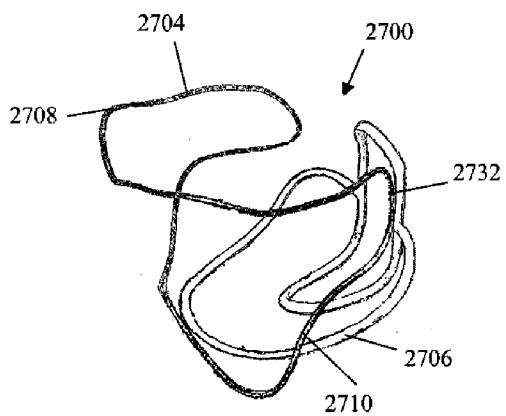

FIG. 27A

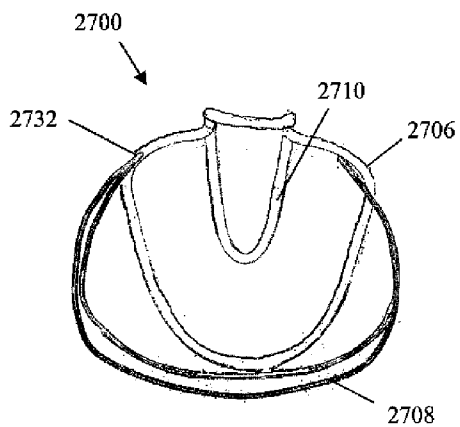

FIG. 27B

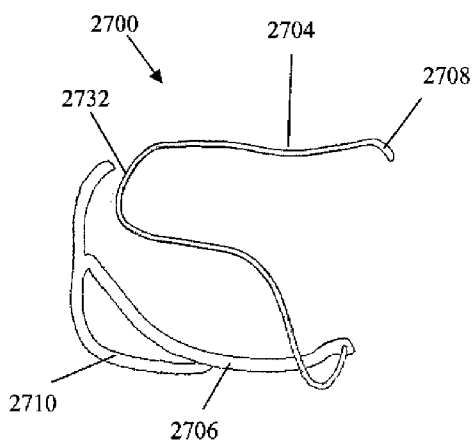

FIG. 27C

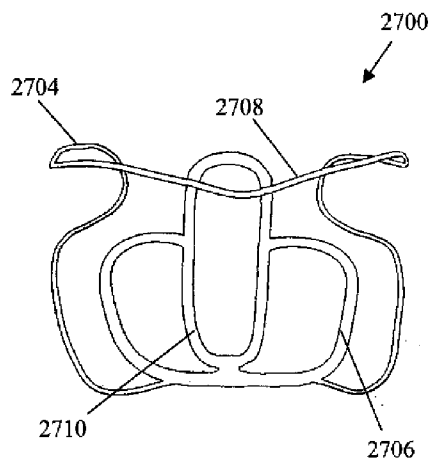

FIG. 27D

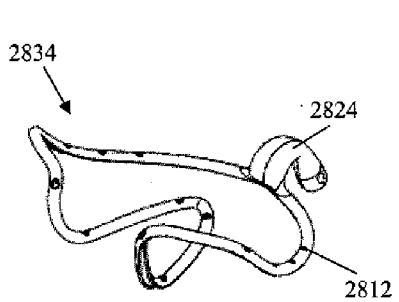

FIG. 28A

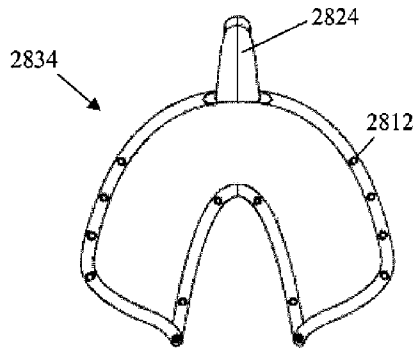

FIG. 28B

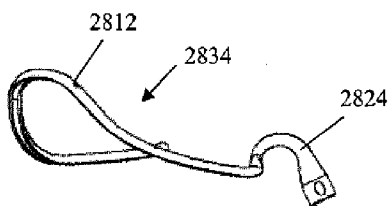

FIG. 28C

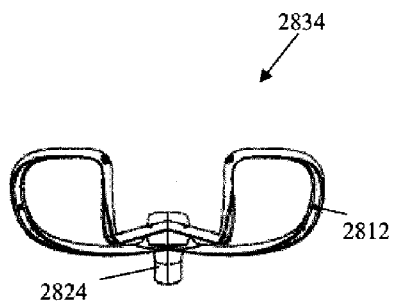

FIG. 28D

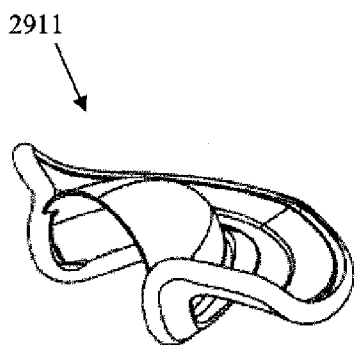

FIG. 29A

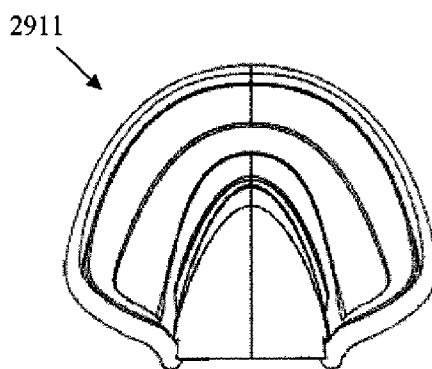

FIG. 29B

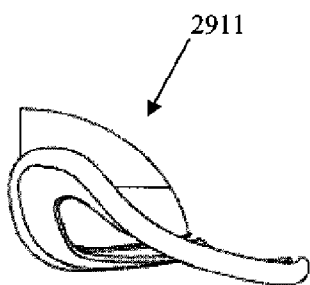

FIG. 29C

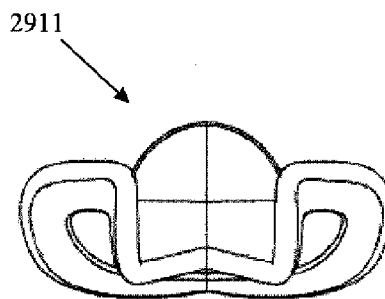

FIG. 29D

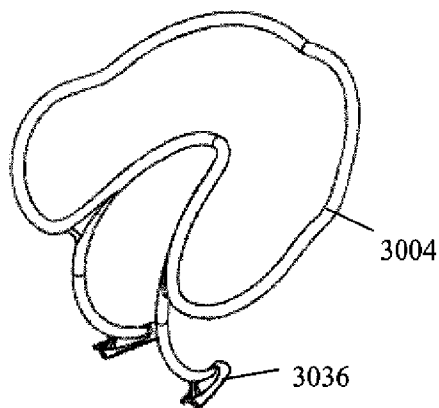

FIG. 30A

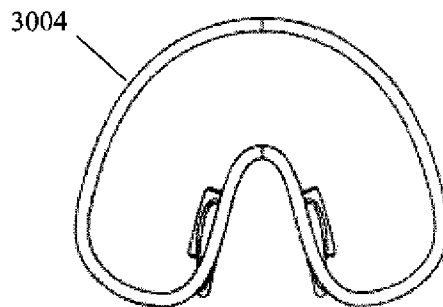

FIG. 30B

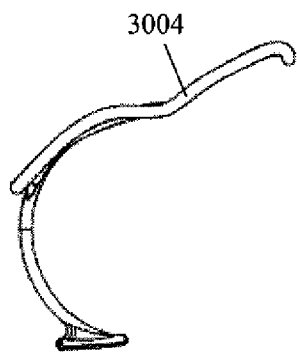

FIG. 30C

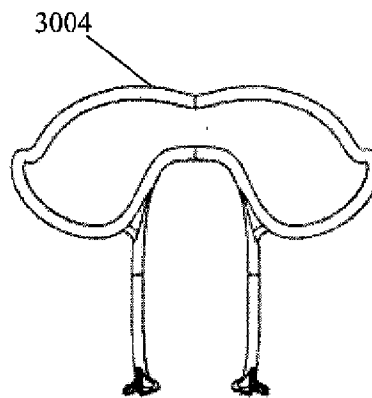

FIG. 30D

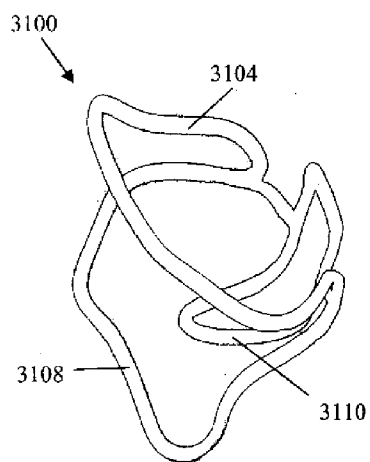

FIG. 31A

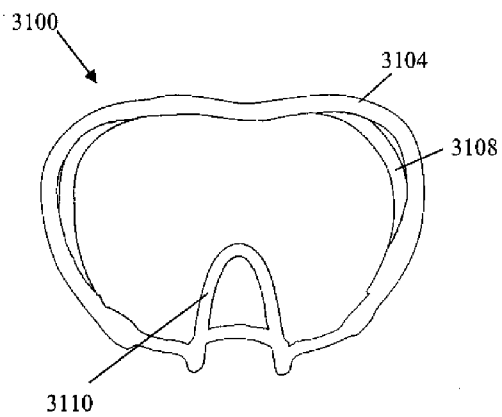

FIG. 31B

3104

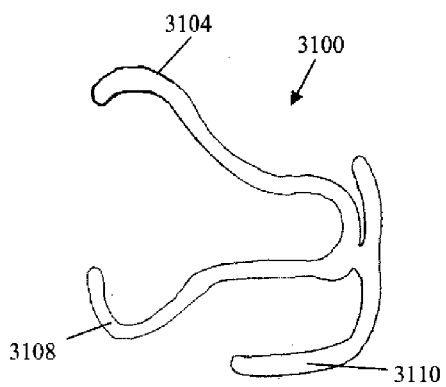

FIG. 31C

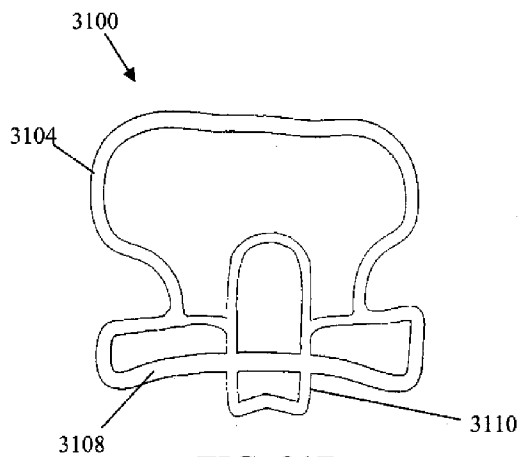

FIG. 31D

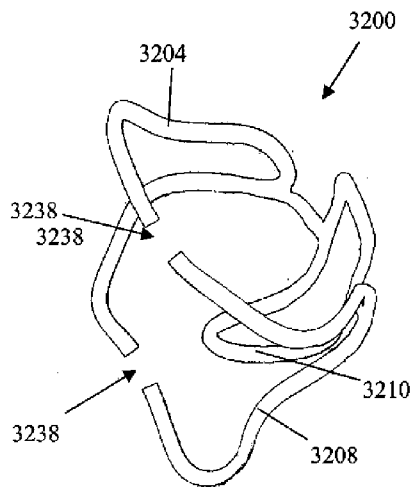

FIG. 32A

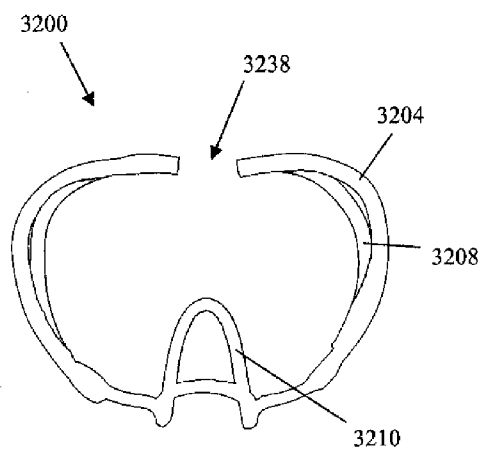

FIG. 32B

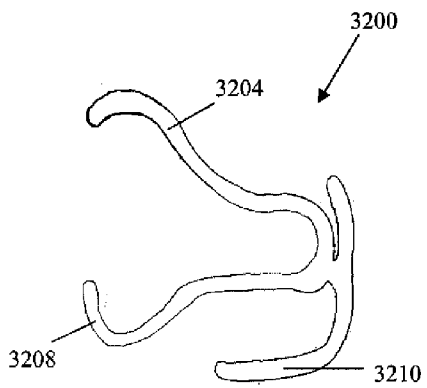

FIG. 32C

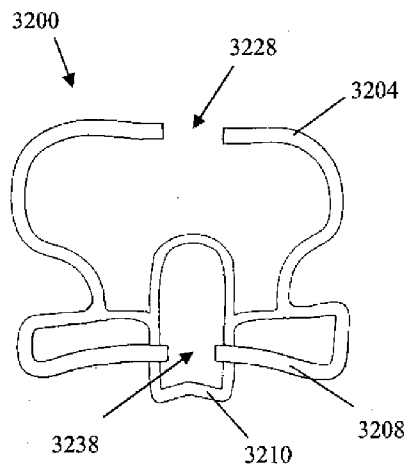

FIG. 32D

**METHODS, DEVICES, SYSTEMS,
ASSEMBLIES, AND KITS FOR TISSUE
RETRACTION IN AN ORAL CAVITY**

CROSS-REFERENCE

[0001] This application claims the benefit of U.S. Provisional Application No. 60/975,387, filed Sep. 26, 2007, U.S. Provisional Application No. 61/026,989, filed Feb. 7, 2008, and U.S. Provisional Application No. 61/081,908, filed Jul. 18, 2008, which are incorporated herein by reference in their entireties.

BACKGROUND OF THE INVENTION

[0002] The mouth or oral cavity **10** of a human is illustrated in FIG. 1A to provide context for the invention. The mouth, or oral cavity, is bounded by muscles and bones: anteriorly by the lips **12**, posteriorly continuous with the oropharynx, laterally by the muscles of the cheeks **14**, superiorly by the body hard palate and muscular soft palate **16**; and inferiorly by the muscular tongue **18** and the soft tissues of the floor of the mouth. The tongue is a voluntary muscular structure that occupies the floor of the mouth. Teeth **20** are embedded in the alveoli or sockets of alveolar ridges of the mandible **30** which forms a mandibular arch **32**, or alveolar process, which contain the lower (caudad) set of teeth and maxilla **40** which forms a maxillary arch **42**, or alveolar process, which contains the upper (cephalad) set of teeth. Each of the alveolar arch **32**, **42**, has an external surface **34**, **44** which is adjacent the cheeks and lips and an internal surface **36**, **46** adjacent the tongue and palate. The teeth **20** engage the gingival tissue **22**.

[0003] The mouth **10** has salivary glands that secrete about 1.5 L of fluid daily into the mouth. Secretion of saliva is controlled by the autonomic nervous system. Parasympathetic stimulation causes vasodilation and secretion of water saliva with low enzyme content, whereas sympathetic stimulation causes vasoconstriction and secretion of smaller amounts of saliva that are richer in organic materials. Reflex secretion occurs when, for example, there is food in the mouth.

[0004] Devices and systems currently known and used in the dental arts include those disclosed in: U.S. Pat. No. 4,695,253 to Tysse for Oral Evacuation Device and Method; U.S. Pat. No. 6,981,870 to Heasley for Rubber Dam Clamps Retained by Adhesion and Improved Frictional Forces; U.S. Pat. No. 6,022,214 to Hirsch et al. for Intraoral Illumination Device and Method of Using Same; U.S. Pat. No. 5,931,673 to Bobolan for Intraoral Dental Dam; U.S. Pat. No. 5,890,899 to Scalfani for Dental Isolator; U.S. Pat. No. 5,516,286 to Kushner for Dental Isolation Tray Particularly Suited for Use When Applying Dental Sealants and Method for Its Use; U.S. Pat. No. 5,460,524 to Anderson for Device and Method for Saliva Suction with Tongue Retractor and Bit Handle; U.S. Pat. No. 5,078,604 to Malmin for Dental Barrier Drape Devices and Retainer Apparatus Therefor; U.S. Pat. No. 5,037,298 to Hickham for Apparatus and Improves Process for Removing Saliva While Retracting Cheeks and Lips; U.S. Pat. No. 4,899,490 to Jenkinson for Dental Mask; U.S. Pat. No. 4,215,477 to Shanel for Holder for Rubber Dental Dam; U.S. Pat. No. 3,772,790 to Swan-Gett et al. for Tooth Isolating Shield; U.S. Patent Publication US 2004/0170945 to Heasley for General Field Isolation Rubber Dams without Operative Inserts Which Isolate the Dental Alveolar Arch for Dental

Treatment; and US 2007/0231773 to Pontynen et al. for Methods, Devices, Systems, and Kits for Isolating Teeth.

[0005] Commercially available devices include, for example, Isolite i2 by Isolyte Systems (Santa Barbara, Calif.), described at www.isolitesystems.com; OptiDam by KerrHawe SA (Switzerland), described at www.kerrhawe.com; and OptraGate and OptraDam by Ivoclar Vivident Ltd. (New Zealand), described at www.ivoclar.co.nz.

[0006] It would be beneficial to have a device, system, assembly, kit and method that enables dental practitioners to quickly retract tissue and isolate one or more teeth and/or gingival tissue in the oral cavity from surrounding tissue to generate a working field and which maintains a dry working field for performing the dental procedure.

SUMMARY OF THE INVENTION

[0007] Provided herein is a retraction device comprising a topology conformable structure adaptable to be in a constrained shape that can be delivered into an oral cavity and further adaptable to be in an unconstrained shape to create a useable working field in the oral cavity, the useable working field providing increased accessibility and increased visibility within the oral cavity. In some embodiments, the conformable structure is a frame. Additionally, the frame can further comprise a membrane. The frame can also comprise a light source. The frame can also comprise an evacuation component. The device can be adaptable to be deployed in under 1 minute. In some embodiments, the device can be adaptable to create a working field in under 1 minute. The device can be deployed in under 20 seconds. The device can further comprise a tongue retractor wherein the tongue retractor can be adaptable to deflect the tongue without passing over either arch of teeth. The tongue retractor can contain and confine the tongue in a restricted space. In some embodiments, the device can further comprise at least one evacuation component. The evacuation component can be used to remove saliva or other bodily fluids from the oral cavity. Additionally, the evacuation component can be used to remove moist air or breath from the oral cavity. The device can be adaptable to retract soft tissue surrounding at least one arch of teeth. Additionally, the device can be adaptable to retract the soft tissue surrounding both the upper and lower arches of teeth in the oral cavity. The device can also be used in some cases to isolate at least a portion of gum tissue in the oral cavity. In isolating the teeth of gum tissue, the device can be used to create a barrier that can be efficiently separate dental surfaces from any influence by saliva or other body fluids. Furthermore, the device can comprise at least one aperture to facilitate the ability to breathe through the device. The device can facilitate the scanning of the dental surfaces by providing increased accessibility to the oral cavity and increased visibility within the structures within the oral cavity. The device can facilitate scanning or imaging of the oral cavity, wherein the scanning or imaging comprises at least one of digital scanning/imaging or optical scanning/imaging. Furthermore, the device can be adaptable to isolate both arches of teeth in less than 20 seconds. In some embodiments, the device can be adaptable to be positioned without interfering with access to dental surfaces, while also being further adaptable to prevent interference with access to dental surfaces by the tongue, cheeks or lips and further adaptable to provide maximum patient comfort.

[0008] Further provided herein is a retraction device comprising a topology conformable structure adaptable to create a working field in an oral cavity of a patient, wherein the

working field is at least 10% larger than a working field created in the oral cavity of the patient without use of the device. The device can be used to provide at least 10% more access to an area of interest in the oral cavity. In some embodiments, the area of interest is one arch of teeth. Alternatively, the area of interest can be both arches of teeth. The device can be adaptable to provide at least 10% more visibility within the oral cavity. The device can be adaptable to provide at least 10% less contamination of structures located in the oral cavity by fluid. The fluid can be saliva, blood, or any other suitable bodily fluid. In some embodiments, the device can be adaptable to provide at least 10% less interference by soft tissue in accessing structures in the oral cavity. The conformable structure can be a frame. The device can be adaptable to evacuate bodily fluids from a protected side of the oral cavity and also any fluid used to rinse the oral cavity on the working field side of the membrane during a procedure. In some embodiments, the device can comprise a full membrane that can isolate the oral cavity from harmful debris or undesirable chemicals and tastes. In some embodiments, the frame is a wire frame. In some embodiments, the device further comprises a membrane. Additionally, the device can comprise a light source. The light source can be used to illuminate the oral cavity. The light source can be used to cure materials placed in the oral cavity. Alternatively, the device can comprise light sources that can either illuminate or cure material. The device can be adaptable to isolate at least one arch located within the oral cavity or create a barrier that can efficiently separate dental surfaces from any influence by saliva or other bodily fluid. The device can be adaptable to isolate the upper arch and the lower arch in the oral cavity. In some embodiments, the device can be adaptable to isolate at least a portion of gum tissue in the oral cavity. The device can be used to isolate the entire gum tissue. Furthermore, the device can be adaptable to be deployed in under 1 minute. The device can also be adaptable to create a working field in under 1 minute. In some embodiments, the device can be deployed in under 20 seconds. Additionally, no further adjustment of the device can be needed after the device has been deployed. In some embodiments, the device can further comprise a tongue retractor. The tongue retractor can contain and confine the tongue in a restricted space. The tongue retractor and the elements which attach it to the rest of the device can be adaptable to allow a first occlusal surface of a tooth in the upper arch of teeth and a second occlusal surface of a tooth in the lower arch of teeth to touch. The tongue retractor can be adaptable to compress at least one side of the tongue or both sides of the tongue. The device can be adaptable to apply suction to the oral cavity through at least one aperture. The device can also be adaptable to facilitate the ability to breathe through the device. The device can be adaptable to isolate at least one dental arch or create a barrier around the at least one dental arch in less than 20 seconds. The device can further be adaptable to be positioned without interfering with access to dental surfaces and further adaptable to provide maximum patient comfort.

[0009] Additionally, provided herein is a retraction device comprising a malleable frame adaptable to be in a constrained shape that can be delivered into an oral cavity and further adaptable to be in an unconstrained shape to isolate at least one arch of teeth from saliva and soft tissue surrounding the arch. The malleable frame can be a wire frame, including but not limited to a metal wire. Alternatively, the wire frame can be a polymer frame or a combination of metal and polymer

frame. The malleable frame can further comprise a membrane. Additionally, the device can further comprise a light source. In some embodiments, the device can be adaptable to be deployed in under 1 minute. The device can be adaptable to be deployed in under 20 seconds, in some embodiments. The device can also be adaptable to create a working field in under 1 minute. Furthermore, the device can comprise a tongue retractor. The tongue retractor can contain and confine the tongue. The tongue retractor and the elements which attach it to the rest of the device can be adaptable to allow a first occlusal surface of a tooth in the upper arch of teeth and a second occlusal surface in the lower arch of teeth to touch. The device can also comprise at least one evacuation component. The device can be adaptable to retract soft tissue surrounding at least one arch of teeth or in some cases, retract the soft tissue surrounding the upper and lower arches of teeth. The device can be adaptable to isolate at least a portion of gum tissue located in the oral cavity. In some embodiments, the device further comprises at least one aperture to facilitate the ability to breathe through at least one aperture in the device. The device can be further adaptable to facilitate the application of a substance to at least one tooth surface. The substance can be a powder. In some embodiments, the powder is a reflective powder. The powder can be an imaging powder for patterning the dental surfaces. The substance can be a dental restorative material or medication. The device can be adaptable to facilitate the application of hardware (orthodontic brackets) to at least one tooth surface. The device can be further adaptable to facilitate treatment of at least one periodontal pocket using including, but not limited to, a laser device, an ultrasonic or sonic frequency scaler device, treatment with hand scalers and curettes, periodontal surgery, or dental implant placement, or any suitable combination thereof. The device can also be adaptable to isolate at least one dental arch in less than 20 seconds. The device can be adaptable to create a working field without interfering with access to dental surfaces. The device can be further adaptable to be positioned in the mouth to provide for maximum patient comfort.

[0010] Further provided herein are methods of use of the invention described herein. Provided herein is a method of retracting tissue in an oral cavity comprising: inserting a retraction device comprising a topology conformable structure adaptable to be in a constrained shape that can be delivered into an oral cavity and further adaptable to be in an unconstrained shape to create a useable working field in the oral cavity, the useable working field providing increased accessibility to and increased visibility within the oral cavity; and positioning the retraction device in the oral cavity to create the useable working field. The positioning step can be performed in less than 1 minute. In some embodiments, the positioning step can be performed in less than 20 seconds.

[0011] Yet another method for retracting tissue in an oral cavity comprises: inserting a retraction device comprising a topology conformable structure adaptable to create a useable working field in an oral cavity of a patient, wherein the working field is at least 10% larger than a working field in oral cavity of the patient without use of the device; and positioning the retraction device in the oral cavity to create the working field.

[0012] Another method provided herein is a method of facilitating the creation of an oral cavity model comprising: inserting a retraction device comprising a topology conformable structure adaptable to be in a constrained shape that can

be delivered into an oral cavity and further adaptable to be in an unconstrained shape to create a useable working field in the oral cavity, the useable working field providing increased accessibility to and increased visibility within the oral cavity; and positioning the retraction device in the oral cavity to create the useable working field in the oral cavity. In some embodiments, the method can further comprise the step of illuminating the oral cavity with the retraction device. Additionally, the method can comprise the step of applying an imaging powder to the at least one dry tooth surface.

[0013] Further provided herein are kits for retracting tissue in an oral cavity. Provided herein are kits for retracting tissue in an oral cavity comprising: a topology conformable structure adaptable to be in a constrained shape that can be delivered into an oral cavity and further adaptable to be in an unconstrained shape to create a useable working field in the oral cavity, the useable working field providing increased accessibility to and increased visibility within the oral cavity. In some embodiments, the kit can further comprise a tongue retractor. Additionally, the kit can further comprise a light ring. Furthermore, the kit can comprise an evacuation component. The kit can further comprise a membrane adaptable to be fitted over the frame. In some embodiments, the kit can further comprise a gum protection cover. The kit can also further comprise a lip ring.

[0014] Furthermore, additionally provided herein is a kit for retracting tissue in an oral cavity comprising: a retraction device comprising a topology conformable structure adaptable to be in a constrained shape that can be delivered into an oral cavity and further adaptable to be in an unconstrained shape to create a useable working field in the oral cavity, the useable working field providing increased accessibility to and increased visibility within the oral cavity; and a kit of secondary dental products wherein tissue retraction in the oral cavity is necessary. In some embodiments, the kit can further comprise an illumination source. Additionally, the kit can comprise at least one optical scanner or digital scanner. Furthermore, the kit can further comprise a powder for facilitate scanning of the dental surfaces. In some embodiments, the kit can further comprise a whitening or bleaching kit.

INCORPORATION BY REFERENCE

[0015] All publications, patents, and patent applications mentioned in this specification are herein incorporated by reference to the same extent as if each individual publication, patent, or patent application was specifically and individually indicated to be incorporated by reference.

BRIEF DESCRIPTION OF THE DRAWINGS

[0016] The novel features of the invention are set forth with particularity in the appended claims. A better understanding of the features and advantages of the present invention will be obtained by reference to the following detailed description that sets forth illustrative embodiments, in which the principles of the invention are utilized, and the accompanying drawings of which:

[0017] FIG. 1A depicts an anterior view of an oral cavity with the mouth open and the teeth exposed illustrating the structures of the oral cavity; FIG. 1B is an illustration of a human body with the anatomical planes of the body identified;

[0018] FIGS. 2A-2E illustrate one embodiment of a retraction device positioned in the oral cavity of a patient; FIG. 2A

is a perspective view of the device positioned in the oral cavity; FIG. 2B is a side view of the retraction device positioned within the oral cavity; FIG. 2C depicts a portion of the retraction device positioned over the caudad portion of the oral cavity as viewed along the line B-B in FIG. 2B;

[0019] FIG. 2D depicts a portion of the retraction device positioned over the caudad portion of the oral cavity as viewed along the line B-B in FIG. 2B, without surrounding tissue structures; FIG. 2E depicts a portion of the retraction device positioned over the cephalad portion of the oral cavity as viewed along the line B-B in FIG. 2B; FIG. 2F depicts an anterior view of the device positioned in the oral cavity; FIG. 2G depicts a cross-sectional view of the device, and surrounding tissue structures, along the sagittal plane;

[0020] FIGS. 3A-3D illustrate one embodiment of a retraction device; FIG. 3A is perspective view of the retraction device as viewed from the distal end of the device; FIG. 3B is a top view of the retraction device; FIG. 3C is a side view of retraction device; FIG. 3D is a posterior view of the retraction device;

[0021] FIGS. 4A-4D illustrate the tongue and gum protection cover isolated from the retraction device;

[0022] FIG. 4A is a perspective view of the tongue and gum protection cover of the retraction device as viewed from the distal end of the device; FIG. 4B is a top view of the tongue and gum protection cover of the retraction device; FIG. 4C is a side view of the tongue and gum protection cover of the retraction device;

[0023] FIG. 4D is a posterior view of the tongue and gum protection cover of the retraction device;

[0024] FIGS. 5A-5D illustrate the frame covering both the upper and lower arches of the retraction device, isolated from the membrane of the retraction device; FIG. 5A is a perspective view of the frame as viewed from the distal end of the device; FIG. 5B is a top view of the frame of the retraction device;

[0025] FIG. 5C is a side view of the frame of the retraction device; FIG. 5D is a posterior view of the frame of the retraction device;

[0026] FIGS. 6A-6D illustrate the light ring portion of the retraction device isolated from the retraction device; FIG. 6A illustrates a perspective view of the light ring as viewed from the posterior side; FIG. 6B illustrates a top view of the light ring; FIG. 6C illustrates a side view of the isolated light ring; FIG. 6D illustrates a posterior view of the light ring;

[0027] FIGS. 7A-7D illustrate an alternative embodiment of a retraction device without a tongue or gum protection component; FIG. 7A illustrates the retraction device as viewed from the distal end of the device; FIG. 7B illustrates a top view of the retraction device; FIG. 7C illustrates a side view of the retraction device; FIG. 7D illustrates a posterior view of the retraction device;

[0028] FIGS. 8A-8D illustrate an alternative embodiments of a retraction device having a frame covered by a membrane; FIG. 8A illustrates a perspective view of the isolation/retraction device; FIG. 8B illustrates a top view of the isolation/retraction device; FIG. 8C illustrates a side view of the isolation/retraction device; FIG. 8D illustrates a posterior view of the isolation/retraction device;

[0029] FIGS. 9A-9D illustrate the isolation membrane or cover of the retraction device isolated from the retraction device; FIG. 9A illustrates a perspective view of the isolation membrane of the retraction device; FIG. 9B illustrates a top view of the isolation membrane of the retraction device; FIG.

9C illustrates a side view of the isolation membrane/cover of the retraction device; FIG. 9D illustrates a posterior view of the isolation membrane/cover of the retraction device;

[0030] FIGS. 10A-10D) illustrate an alternative embodiment of a light ring and lip and cheek retractor isolated from a retraction device; FIG. 10A illustrates a perspective view of the light ring; FIG. 10B illustrates a top view of the isolated light ring; FIG. 10C illustrates a side view of the isolated light ring;

[0031] FIG. 10D illustrates a posterior view of the isolated light ring;

[0032] FIGS. 11A-11D illustrate an alternate embodiment of a light ring comprising a flexible electrical circuit membrane; FIG. 11A illustrates a perspective view of the light ring; FIG. 11B illustrates a top view of the isolated light ring; FIG. 11C illustrates a side view of the isolated light ring; FIG. 11D illustrates a posterior view of the isolated light ring;

[0033] FIGS. 12A-12D illustrate an alternate embodiment of an isolated frame of a retraction device, including tongue cover, and lip and cheek retraction ring; FIG. 12A illustrates a perspective view of the frame; FIG. 12B illustrates a top view of an isolated frame; FIG. 12C illustrates a side view of an isolated frame; FIG. 12D illustrates a posterior view of the isolated frame;

[0034] FIGS. 13A-13D illustrate an alternate embodiment of an isolated frame of a retraction device; FIG. 13A illustrates a perspective view of the frame; FIG. 13B illustrates a top view of an isolated frame of the retraction device; FIG. 13C illustrates a side of the frame; FIG. 13D illustrates a posterior view of the isolated frame;

[0035] FIGS. 14A-14D illustrate an isolated view an alternate embodiment of a frame; FIG. 14A illustrates a perspective view of the frame; FIG. 14B illustrates a top view of the frame; FIG. 14C illustrates a side view of the frame; FIG. 14D illustrates a posterior view of the frame;

[0036] FIGS. 15A-15D illustrate an alternate embodiment of a frame comprising an evacuation component; FIG. 15A illustrates a perspective view of the frame; FIG. 15B illustrates a top view of the frame; FIG. 15C illustrates a side view of the frame; FIG. 15D illustrates a posterior view of the frame;

[0037] FIGS. 16A-16D illustrate an alternative embodiment of an isolated lip ring; FIG. 16A illustrates a perspective view of the lip ring as viewed from the distal side; FIG. 16B illustrates a top view of the lip ring; FIG. 16C illustrates a side view of the lip ring; FIG. 16D illustrates a posterior view of the lip ring;

[0038] FIGS. 17A-17D illustrate an embodiment of an isolated tongue cover; FIG. 17A illustrates a perspective view of the tongue cover; FIG. 17B illustrates a top view of a tongue cover; FIG. 17C illustrates a side view of a tongue cover; FIG. 17D illustrates a posterior view of a tongue cover;

[0039] FIGS. 18A-18D illustrates an alternate embodiment of an frame adaptable to be folded; FIG. 18A illustrates a perspective view of the frame as viewed from the distal end; FIG. 18B illustrates a top view of the frame; FIG. 18C illustrates a side view of the frame; FIG. 18D illustrates a posterior view of the frame;

[0040] FIGS. 19A-19D illustrates an alternative embodiment of a foldable frame without a tongue cover; FIG. 19A illustrates a perspective view of the frame as viewed from the distal end; FIG. 19B illustrates a top view of the frame; FIG. 19C illustrates a side view of the frame; FIG. 19D illustrates a posterior view of the frame;

[0041] FIGS. 20A-20D illustrate isolated cheek retractors from a foldable frame; FIG. 20A illustrates a perspective view of the cheek retractors; FIG. 20B illustrates a top view of the cheek retractors; FIG. 20C illustrates a side view of the cheek retractors; FIG. 20D illustrates a posterior view of the cheek retractors;

[0042] FIGS. 21A-21D illustrate a retraction device for retracting tissue surrounding the lower arch, tongue, cheeks, and lips, including lighting and suction; FIG. 21A illustrates a perspective view of the retraction device as viewed from the distal side; FIG. 21B illustrates the retraction device as viewed from top; FIG. 21C illustrates a side view of the retraction device; FIG. 21D illustrates a posterior view of the retraction device;

[0043] FIGS. 22A-22D illustrates an alternative embodiment of a retraction device comprising a frame with gum protector and tongue cover; FIG. 22A illustrates a perspective view of the retraction device as viewed from the distal side; FIG. 22B illustrates a top view of the retraction device; FIG. 22C illustrates a side view of a retraction device; FIG. 22D illustrates a posterior view of a retraction device;

[0044] FIGS. 23A-23D illustrate an alternative embodiment of a membrane isolated from the retraction device comprising a gum protector, a tongue cover and evacuation component; FIG. 23A illustrates a perspective view of the retraction device as viewed from the distal end; FIG. 23B illustrates a top view of the retraction device; FIG. 23C illustrates a side view of the retraction device; FIG. 23D illustrates a posterior view of the retraction device;

[0045] FIGS. 24A-24D illustrate an isolated view of an alternate embodiment of a frame comprising an evacuation component; FIG. 24A illustrates a perspective view of the frame as viewed from the distal end; FIG. 24B illustrates a top view of the frame; FIG. 24C illustrates a side view of the frame; FIG. 24D illustrates a posterior view of the frame;

[0046] FIGS. 25A-25D illustrate an alternate embodiment of a retraction device comprising a lower frame and gum protector and light lip ring; FIG. 25A illustrates a perspective view of the retraction device as viewed from the distal end; FIG. 25B illustrates a top view of the frame; FIG. 25C illustrates a side view of the frame; FIG. 25D illustrates a posterior view of the frame;

[0047] FIGS. 26A-26D illustrate an alternate embodiment of a retraction device comprising a lower arch frame and a tongue cover; FIG. 26A illustrates a perspective view of the retraction device; FIG. 26B illustrates a top view of the retraction device; FIG. 26C illustrates a side view of the retraction device; FIG. 26D illustrates a posterior view of the retraction device;

[0048] FIGS. 27A-27D illustrates an alternative embodiment of retraction device comprising an upper and lower arch frame and tongue cover; FIG. 27A is a perspective view of the frame as viewed from the front; FIG. 27B illustrates a top view of the retraction device; FIG. 27C illustrates a side view of the retraction device; FIG. 27D illustrates a view of the retraction device as viewed from the top;

[0049] FIGS. 28A-28D illustrate an alternate embodiment of an isolated frame comprising an evacuation component; FIG. 28A illustrates a perspective view of the frame as viewed from the distal side; FIG. 28B illustrates a top view of the frame; FIG. 28C illustrates a side view of the frame; FIG. 28D illustrates a posterior view of the frame;

[0050] FIGS. 29A-29D illustrate an isolated tongue cover; FIG. 29A illustrates a perspective view of the tongue cover as

viewed from the distal side; FIG. 28B illustrates a top view of the tongue cover; FIG. 29C illustrates a side view of the tongue cover; FIG. 29D illustrates a posterior view of the tongue cover;

[0051] FIGS. 30A-30D illustrates an isolated upper arch frame; FIG. 30A illustrates a perspective view of the frame; FIG. 30B illustrates a top view of frame; FIG. 30C illustrates a side view of the frame; FIG. 30D illustrates a posterior view of the frame;

[0052] FIGS. 31A-31D illustrates an alternative embodiment of an isolated upper and lower arch frame; FIG. 31A illustrates a perspective view of the frame; FIG. 31B illustrates a top view of frame; FIG. 31C illustrates a side view of the frame; FIG. 31D illustrates a frontal view of the frame; and

[0053] FIGS. 32A-32D illustrates an alternative embodiment of a retraction device frame; FIG. 32A illustrates a perspective view of the frame; FIG. 32B illustrates a top view of frame; FIG. 32C illustrates a side view of the frame; FIG. 32D illustrates a frontal view of the frame.

DETAILED DESCRIPTION OF THE INVENTION

[0054] In order to understand the configurability, adaptability and operational aspects of the invention, it is helpful to understand the anatomical references of the body 50 with respect to which the position and operation of the device, and components thereof, are described. There are three anatomical planes generally used in anatomy to describe the human body and structure within the human body: the axial plane 52, the sagittal plane 54 and the coronal plane 56 (see FIG. 1B). Additionally, devices and the operation of devices are better understood with respect to the caudad 60 direction and/or the cephalad direction 62. Devices positioned within the body can be positioned dorsally 70 (or posteriorly) such that the placement or operation of the device is toward the back or rear of the body. Alternatively, devices can be positioned ventrally 72 (or anteriorly) such that the placement or operation of the device is toward the front of the body. Various embodiments of the device for isolating teeth, systems and kits of the present invention may be configurable and variable with respect to a single anatomical plane or with respect to two or more anatomic. Similarly, the various components can incorporate differing sizes and/or shapes in order to accommodate differing patient oral cavity sizes.

[0055] Provided herein is a retraction device for isolating the lower and upper arches of teeth located in the oral cavity. The retraction device can isolate the lower and upper arches of teeth. Additionally, the retraction device can isolate gum tissue located adjacent to the lower and upper arches. By isolating the dental surfaces, the device can be used to create a barrier that can efficiently separate the dental surfaces from any influence by saliva or other body fluids. A portion of the gum tissue can be isolated or the entire gum tissue can be isolated. The present invention contemplates devices adapted and configured to retract tissue in the oral cavity away from one or more dental arches or from one or more teeth. By retracting the tissue, teeth are set apart or kept away from other tissue, saliva, and debris to create a site within the oral cavity suitable to perform a dental procedure, such as dental imaging. As will be appreciated by those skilled in the art, because the teeth are embedded in the jaw bone, a target tooth is not per se "isolated" from a neighboring tooth. However, the devices, can be configured such that the target tooth is isolated from a neighboring tooth such that the neighboring

tooth is not impacted by the use of dental materials during a procedure on the target tooth. Isolation of one or more target teeth can also include exposing those teeth to create a surgical sit, or site for performing a procedure. Isolation of one or more target teeth can also include creating a barrier that can efficiently separate dental surfaces from any influence by saliva or other body fluids.

[0056] The devices are further configured such that they are rapidly deployable. The devices are able to quickly achieve a dry working field and substantially maintain the working field condition during the procedure without the need for interaction. The device can isolate at least one arch of teeth in seconds. In some embodiments, the device can be deployed to isolate the upper and lower arches of teeth in less than about 60 seconds or 1 minute. In some embodiments, the device can be deployed to isolate the upper and lower arches of teeth in less than about 1 minute. In some embodiments, the device can be deployed to isolate the upper and lower arches of teeth in less than about 20 seconds.

[0057] In some embodiments, a device of the present invention is a single unit apparatus that can be positioned within a patient's mouth to isolate one or more of the patient's teeth by retracting tissue, including the tongue. The ability to retract the tongue provides considerable advantage for accessing the oral cavity. For example, a device can be a single arch that isolates only the upper teeth or a portion thereof or a single arch that isolates only the lower teeth or a portion thereof. Such single-arch devices which isolate only lower or upper teeth can be used independently or in combination with one another to form a two piece device. In some embodiments, a single arch (e.g., lower arch) device is coupled to a paddle that isolates the other half of the mouth and tongue (e.g., the upper teeth) and/or keeps the mouth open. Since the device herein is shaped like the mouth, the device can be inserted into a patient's mouth accurately in about one minute or less or about 20 seconds or less.

[0058] The devices herein include one or more retractors. A retractor is an element that deflects, retracts, or displaces soft tissue, such as lips, tongue and/or cheek(s), away from teeth and/or alveolar surfaces. In some embodiments, a device comprises one retractor. In some embodiments, a device comprises two retractors. The tongue can be deflected by an open tongue retractor structure, such as a wire tongue retractor. Alternatively, the tongue retractor can include a cover for containing the tongue from the sides. The tongue can be entirely confined within the tongue retractor so that the tongue is confined within a restricted space and thereby prevented from filling the oral cavity. Additional retractors can be used, especially when each retractor uniquely retracts a different portion of the cheek(s) and/or lip(s).

[0059] Devices can further be adapted and configured to provide one or more apertures that correspond with one or more upper and/or lower teeth. A lower retractor may be provided adjacent an aperture for the lower teeth such that it is adapted and configured to extend or protrude the lower lip and cheeks away from the lower teeth, or at least a target lower tooth, e.g. where only one tooth is exposed through the lower tooth aperture. Similarly, an upper retractor may be positioned adjacent an aperture corresponding to one or more upper teeth, wherein the retractor is adapted and configured to extend or protrude the upper lip and cheeks away from the upper teeth, or at least a target upper tooth. The upper and/or lower teeth can be inserted into such tooth receiving apertures without impinging on the patient's teeth and without forceful

contact with the alveolar process or gingiva. In some embodiments, additional regions of interest (e.g., gums) may be exposed by using a more minimal device or by removing (such as by cutting) one or more parts of the device as necessary.

[0060] The retractor can have various dimensions to achieve suitable to achieve creation of a working field around a target tooth or teeth. Thus, the length, height, curvature, and width can be adjusted to take into account the size of the mouth and/or the facial features of the patient. For example, in some embodiments, retractors can be configured to increase in size as the retractor extends away from the alveolar arch to allow for retraction of more cheek muscle. In some embodiments, a lower retractor and/or an upper retractor is between about 1 mm to about 10 cm in height. Retractors for children, adults, and animals can have different lengths, widths, curvatures, etc.

[0061] The lower and upper retractors can be adapted to extend to the back of the mouth where the retractors interconnect. For example, the lower and upper retractors may be connected on both the right and left back (posterior) sides of the mouth, e.g. immediately posterior the most posteriorly positioned tooth, via a flexible bridge that permits the patient to open and close their mouth with the device fully deployed therein. Such a bridge can include, for example, one or more features adapted to increase flexibility or rigidity. In some embodiments, the bridges comprise folds, bellows or ribs which increase its elasticity. In some devices, the bridges are made of a different material than the retractors. Additionally, the lower and upper retractors can be connected via an inflexible bridge forcing a patient to keep their mouth open at a specified angle. In some embodiments, the bridges are designed to help keep a patient's mouth open but also provide flexibility to permit closing of the mouth.

[0062] A flange or bridge (such as "webbing") can also be provided that connects the anterior portion of the lower retractor prevents the tongue from dislodging the device by positioning the tongue over the top of the webbed portion described.

[0063] The bridges in the back of the mouth can be coupled to or extend into a shield that prevents debris and other components from entering the throat during a dental procedure. The shield can have a proximal curvature to allow extra room for the tongue. In some embodiments, the shield curvature is such that the apex of curvature is in the center of the mouth. In some embodiments, the shield can further act as a tongue containment device, tongue retractor, tongue deflector, tongue suppressor, tongue elevator, tongue support, etc. In some embodiments, the shield comprises an aperture or apertures (mesh) in its center to permit a patient to breathe using their mouth. The aperture allows the patient to breath through the mouth. Additionally, the aperture may be large enough such that the patient can put their tongue into and/or through the aperture. The aperture can also be used to provide access to the back of the mouth e.g. to visualize debris or saliva build-up, as well as to give access to high volume suction.

[0064] Some configurations of the shield are configured to function as a tongue retractor comprises a surface that is a u-shaped flange extending from the inside of the mouth toward the outside. The bottom surface of the tongue retractor can have an internal surface with side surfaces extending from top to bottom forming a barrier between the mouth and the

throat. The throat barrier is below the breathing aperture, which permits the patient to breathe through the mouth during the procedure.

[0065] In some embodiments, a shield can be used to maintain the patient's mouth in an open state. Such shield has a support mechanism above the breathing cavity. The support mechanism may be a u-shaped flange that extends upwardly and externally above the breathing cavity. The support mechanism is adapted to maintain the mouth cavity open. The support mechanism is especially useful for dental surgery, when the patient is unconscious or sedated.

[0066] Devices of the invention can also be adapted and configured to integrate with a saliva ejection or suction/evacuation element. A saliva suction element includes, for example, one or more suction inlets, one or more suction channels, and one or more suction outlets. A suction channel can extend from a region inside the mouth (e.g. posteriorly and then forward in and around the alveolar process under the tongue) to a region near or at the mouth opening (e.g. anteriorly). A suction channel can be integrated into the frame of the device. For example, a suction inlet can be at a region abutting the internal cheek or back of the mouth when the device is deployed. In some embodiment multiple suction inlets align the bottom lower retractors. Such suction inlets are coupled to a single channel leading to an outlet or port in the front of the patient's mouth. A suction channel can extend from the suction inlet within the frame of the device, or external to the device, to a suction outlet or port located at the proximal end of the device herein or proximal to the device herein (external to the mouth). The suction port can be coupled to a suction device external to the patient to draw saliva from the back of the mouth outside the patient. A saliva ejection or suction element enhances the seal around the teeth. In some embodiments, suction channels(s) and outlet(s) are located on the underside (meaning the "tissue side") of the "sealing mechanism" such that the device attaches itself firmly to the alveolar process or upper and lower alveolar processes when suction is applied. The suction actuated sealing mechanism can also consists of a suction channel within the "windshield wiper blade" or retractor element, with perforations positioned in two rows on the tissue side ("underside") of the seal. In the case of the upper arch portion of the device, the perforations are on the superior surface of the seal. When suction is applied to the channel or channels, via a port or ports near the proximal end of the device, the seal(s) adhere(s) to the alveolar process or processes. The suction is also capable of evacuating saliva on the tissue side of the barrier while evacuating debris and other contaminates on the working field side of the barrier.

[0067] The devices herein can also be integrated with a lighting element. As with other components of the invention, the integrated light can be formed integrally, such that it is a constituent piece of the device, or such that the device ultimately forms a single unit, one component of which is the light fixture. Such devices are composed of a translucent material capable of illuminating once it is inserted into the patient's mouth. In some embodiments, the device comprises LED light source or a fiber optic light source, or an effervescent light source either of which can, for example, be embedded in the device or coated on the device. The lighting device can also be configured such that it is powered by an external power source or a power source that is not external. Light

sources can be located along the sides of the device, or along the top or the device or along the bottom of the device or all over the device.

[0068] The devices herein can be manufactured using an elastic but somewhat stiff wire to form the upper and lower retractors. The wire can be encapsulated in silicone and then encapsulated by a soft polymeric material, for example. In some embodiments, the wire is a polymer wire. Alternatively, the wire can be a metal wire. In some embodiments, the wire is used by itself without a soft membrane or coating. In some embodiments, a nickel/titanium alloy wire is used for the frame to optimize the collapsibility of the device for insertion purposes and compliance with mouth shape while providing the forces necessary to accomplish retraction of cheeks and tongue and to position the sealing mechanism. The heat in the oral cavity can activate property changes in the metal springing it into its designed shape making it less intrusive to insert. In some embodiments, a nylon or other plastic material is used for this “wire frame” that may be effected by the body heat also.

[0069] The devices described herein are particularly useful in aiding the imaging or scanning of the dental surfaces located within the oral cavity. The device can be used to create a larger working field, wherein the working field comprises the dental surfaces of interest and the area surrounding the dental surfaces of interest. The devices described herein can be used to create a larger working field to facilitate imaging the oral cavity. The oral cavity can be imaged using radiology equipment, such as X-rays, or to scan the dental surfaces by enabling a better insertion of the scanning device into the oral cavity. Additionally, the larger working field, together with the dry dental surfaces created by the devices, further facilitate the scanning of the dental surfaces by allowing for the placement of a powder on the dental surfaces, wherein the powder aids in the ability to scan the dental surfaces. The devices can also be used to facilitate the generation of dental impressions by ensuring proper placement of dental trays within in the oral cavity since the devices can embody a design with minimal material, thereby taking up less space in the oral cavity. This provides for less interference by both the devices and the soft tissue with the materials and kits needed to create the dental tray. The ability to make a dental impression, utilizing the established, well controlled, full arch working field provided by the device provides a major advantage to the dentist. The dentist can transition directly from procedures involving the teeth or periodontal structures to making an impression of the area or an entire arch of teeth without removing the device or ever compromising the working field required for a complete and accurate impression.

[0070] The remainder of the devices herein can be made from one or more polymeric materials including, but not limited, to c-Flex-thermal plastic elastomer (TPE), silicon, slow recovery foam (SRF), and polypropylene (PP). Preferably, a clear polymer is used to manufacture the devices herein. The material can be embossed or pre-molded into the shape of the inside of the mouth which provides extra comfort to the patient. The device can be composed of one or more materials or of a single material having two or more durometers. In one embodiment, a first material conforms to the shape of the alveolar process(es) and creates a seal around one or more of the teeth while the second material provides a structure that retracts the cheek(s) and tongue, providing a clear working field for the dental practitioner and comfort and safety for the patient. In any of the embodiments herein, a

material can optionally contain a lubricant or flavored lubricant to facilitate insertion and removal. In some embodiments, the device is molded in the practitioner’s office to fit the individual patient. In some embodiments, a practitioner can measure a patient’s mouth, using a sterilizable and reusable “tri-in” device, as an aid in selecting the best size of device for the patient. Overall, the device herein can be made in different sizes to fit different size mouths. In some embodiments, a device herein can be used in veterinary dental procedures. Such devices can be adapted to fit an animal being treated (e.g., dog, cat, horse, etc.). The sealing portion of the device can be formed from any suitable hydrophilic material, hydrophobic material, or a putty (e.g., Van-R reversible hydrocolloid, available from Dux Dental, and vinyl polysiloxane, available from 3M Express).

[0071] Prior to inserting the devices described herein into a patient’s mouth, the devices have a circular circumference as provided by the upper and lower retractors. The devices can have at least one, two, or three apertures—e.g., one for one or more of the lower teeth, and/or one for one or more of the upper teeth, and/or one for the tongue and/or airway and/or the largest (proximal or posteriorly positioned) aperture which is used for access to the working field. The apertures for the target teeth (either upper or lower) can be formed by implanting the device and punching one or more target teeth through a perforated ridge. In some embodiments, a first aperture is designed to expose/isolate all of the target teeth and is c-shaped; a second aperture is designed to expose/isolate all of the target teeth. The first and second apertures border on their exterior end with retractors adapted to retract the lips and cheeks away from all teeth. The upper and lower retractors are coupled in the back of the mouth using flexible bridges that permit the patient to open their mouth at various angles. The bridges are also coupled to a shield with an aperture large enough to allow at least a portion of the patient’s tongue to protrude through it.

[0072] As will be appreciated by those skilled in the art, the devices can be adapted and configured to completely isolate both full arches of teeth and is adapted to permit closing of the mouth. This may allow the upper and lower teeth to come together and permits a dental practitioner to make a judgment about the interaction(s) of upper and lower teeth (e.g., bite). The ability to look at all arch of teeth also permits judgment based on features of other teeth whether they are being worked on or not (e.g., comparing teeth coloration, etc.). Furthermore, exposing a plurality of teeth permits a dental practitioner to work on more than 1, 2, 3, 4, 5, 6 etc., teeth each of which may be located in a different part of the mouth without having to re-adjust the device.

[0073] The devices are adapted and configured for use in a procedure requiring a dry environment, such as performing restoration (e.g., crown and filling work) or creating molds of the oral cavity. Absence of saliva can impact the quality of a tooth impression, especially when making impressions of teeth prepared for laboratory fabricated dental restorations or prostheses. The devices of this invention enable a practitioner to insert the device, optionally perform suction on any saliva that remains in the patient’s mouth or perform any other step to facilitate a dry working field, and then insert impression material onto a tooth, remove that impression material and optionally insert a filling material. The devices permit an impression to be taken and filling added without removing the device so that no impression or filling material goes down the

patient's throat. The devices also helps prevent saliva from getting onto the teeth during the entire period it is placed in the mouth.

[0074] For surgical procedures, the devices can be used to isolate one or more teeth of interest while preventing blood, disposables, implantable parts, implanted related parts, or instruments from getting into the patient's throat. The device can be used to create a barrier that can efficiently prevent inhalation or ingestion of

[0075] The retraction devices described herein can comprise a topology conformable structure adaptable to be in a constrained shape that can be delivered into an oral cavity and further adaptable to be in an unconstrained shape to create a useable working field in the oral cavity, the useable working field providing increased accessibility to and increased visibility within the oral cavity. In some embodiments, the conformable structure is a frame. Additionally, the frame can further comprise a membrane. The frame can also comprise a light source. The device can be adaptable to be deployed in under 1 minute. In some embodiments, the device can be adaptable to create a working field in under 1 minute. The device can be deployed in under 20 seconds. The device can further comprise a tongue retractor wherein the tongue retractor can be adaptable to deflect the tongue without passing over either arch of teeth. The tongue retractor can contain and confine the tongue in a restricted space. In some embodiments, the device can further comprise at least one evacuation element. The device can be adaptable to retract soft tissue surrounding at least one arch of teeth. Additionally, the device can be adaptable to retract the upper and lower arches of teeth in the oral cavity. The device can also be used in some cases to isolate at least a portion of gum tissue in the oral cavity. Furthermore, the device can comprise at least one aperture to facilitate the ability to breathe through the device. The device can facilitate the scanning of the dental surfaces wherein the scanning comprises at least one of digital scanning or optical scanning. Furthermore, the device can be adaptable to isolate both arches of teeth in less than 20 seconds. In some embodiments, the device can be adaptable to be positioned without interfering with access to dental surfaces and further adaptable to provide maximum patient comfort.

[0076] Further provided herein is a retraction device comprising a topology conformable structure adaptable to create a working field in an oral cavity of a patient, wherein the working field is at least 10% larger than a working field created in the oral cavity of the patient without use of the device. The device can be used to provide at least 10% more access to an area of interest in the oral cavity. In some embodiments, the area of interest is one arch of teeth. Alternatively, the area of interest can be both arches of teeth. The device can be adaptable to provide at least 10% more visibility within the oral cavity. The device can be adaptable to provide at least 10% less contamination of structures located in the oral cavity by fluid. The fluid can be saliva, blood, or any other bodily fluid. In some embodiments, the device can be adaptable to provide at least 10% less interference between soft tissue and instruments accessing the oral cavity. The conformable structure can be a frame. In some embodiments, the frame is a wire frame. In some embodiments, the device further comprises a membrane. Additionally, the device can comprise a light source. The device can be adaptable to isolate at least one arch located within the oral cavity. The device can be adaptable to isolate the upper arch and the lower arch in the oral cavity. In some embodiments, the device can be adaptable to isolate at

least a portion of gum tissue in the oral cavity. The device can be used to isolate the entire gum tissue. Furthermore, the device can be adaptable to be deployed in under 1 minute. The device can also be adaptable to create a working field in under 1 minute. In some embodiments, the device can be deployed in under 20 seconds. Additionally, no further adjustment of the device can be needed after the device has been deployed. In some embodiments, the device can further comprise a tongue retractor. The tongue retractor can contain and confine the tongue in a restricted space. The tongue retractor can be adaptable to allow a first occlusal surface and a second occlusal surface to touch. The tongue retractor can be adaptable to compress at least one side of the tongue or both sides of the tongue. The device can be adaptable to apply suction to the oral cavity. The device can be used to evacuate the oral cavity. The device can be adaptable to apply suction to the oral cavity through at least one aperture adaptable to facilitate the ability to breathe through the device. The device can be adaptable to isolate at least one dental arch in less than 20 seconds. The device can further be adaptable to be positioned without interfering with access to dental surfaces and further adaptable to provide maximum patient comfort.

[0077] Additionally, provided herein is a retraction device comprising a malleable frame adaptable to be in a constrained shape that can be delivered into an oral cavity and further adaptable to be in an unconstrained shape to isolate at least one arch of teeth from saliva and soft tissue surrounding the arch. The malleable frame can be a wire frame. The malleable frame can further comprise a membrane. Additionally, the device can further comprise a light source. In some embodiments, the device can be adaptable to be deployed in under 1 minute. The device can be adaptable to be deployed in under 20 seconds, in some embodiments. The device can also be adaptable to create a working field in under 1 minute. Furthermore, the device can comprise a tongue retractor. The tongue retractor can contain and confine the tongue. The tongue retractor can be adaptable to allow a first occlusal surface and a second occlusal surface to touch. The device can also comprise at least one evacuation element. The device can be adaptable to retract soft tissue surrounding at least one arch of teeth or in some cases, retract the soft tissue surrounding the upper and lower arches of teeth. The device can be adaptable to isolate at least a portion of gum tissue located in the oral cavity. In some embodiments, the device further comprises at least one aperture to facilitate the ability to breathe through the device. The device can be further adaptable to facilitate the application of a substance to at least one tooth surface. The substance can be a powder. In some embodiments, the powder is a reflective powder. The powder can help create a pattering on the surface the teeth. The device can also be adaptable to isolate at least one dental arch in less than 20 seconds. The device can be adaptable to create a working field without interfering with access to dental surfaces. The device can be further adaptable to be positioned in the mouth to provide for maximum patient comfort.

[0078] As described above, FIG. 1A depicts an oral cavity 10 from an anterior 72 view with the mouth 10 open and the teeth exposed 20 and FIG. 1B illustrates a human body with the anatomical planes of the body identified.

I. Devices

[0079] FIG. 2A illustrates a perspective view of one embodiment of a retraction device 200, as viewed from the front and at an above angle as positioned within the oral cavity

10. The device 200 can comprise a cheek or soft tissue retraction frame 202. The device can further comprise a lip ring 208 for retracting at least one lip. Additionally, the device can comprise an evacuation component capable of suctioning fluid from the oral cavity. The evacuation component can be in communication, preferably fluid communication, with the oral cavity 10 through at least one inlet 212 in the frame 202. FIG. 2B is a side view of the device 200 as positioned within the oral cavity 10. The frame can be comprised of an upper frame 204 and a lower frame 206. In some embodiments, inlets 212 for evacuating the oral cavity 10 can be located in the upper frame 204 and the lower frame 202. FIG. 2B also illustrates how the lip ring 208 can be used to retract the lips 12, 12'. In some embodiments, the device can further comprise a tongue retractor 210. FIG. 2C illustrates a cross-sectional view of the oral cavity along the line B-B in FIG. 2B. FIG. 2C is a cross-sectional view of the caudal side of the oral cavity. FIG. 2C illustrates the positioning of the upper frame 204 of the device 200 around the gums of the upper dental arch 42, retracting the cheek tissue 14 away from the gums. FIG. 2C also illustrates how the upper portion of the lip ring 208 can retract the upper lip 12. FIG. 2D illustrates the complete frame viewed from the top of the device in position around the upper dental arch and the upper portion of the lip ring 208 without any surrounding soft tissue. The gum protection cover 220 is covering the upper frame in FIG. 2D. FIG. 2E illustrates a cross-sectional view of the oral cavity along the line B-B in FIG. 2B, viewing the cephalic portion of the oral cavity. FIG. 2E illustrates how the lower frame 206 of the device isolates the gums of the lower dental arch from the cheeks tissue 14'. FIG. 2E also illustrates the retraction of the lower lip 12' by the lip ring 208. FIG. 2E also shows inlets 212 in the frame for evacuating fluid from the oral cavity. FIG. 2F illustrates a frontal view of the device 200 in position in the oral cavity 10. FIG. 2F illustrates the upper frame 204 and the lower frame 206 and a lip ring 208. The lower frame 206 has inlets 212 for providing suction. FIG. 2F also illustrates a device 200 with a tongue retractor 210 as viewed from the front. FIG. 2G illustrates a cross-sectional view of the device 200 shown in FIG. 2G along the line C-C.

[0080] FIGS. 3A-3D illustrates one embodiment of an isolated retraction device. FIG. 3A illustrates a perspective view of the device as viewed from the distal end of the device 300. FIG. 3A illustrates an upper frame 304, a lower frame 306, and a lip ring 308. The lower frame comprises inlets 312 for evacuating the oral cavity. FIG. 3A also illustrates a device 300 comprising a lip ring 308 further comprising a light ring 314. The device in FIG. 3A also comprises a tongue retractor 310. FIG. 3B is a top view of the retraction device 300. FIG. 3B illustrates the upper frame with gum protection cover 320, the top portion of the lip ring 308, and the light sources 316, 316' for providing light to the light ring portion of the lip ring 308. The light source can either be isolated power sources for light, such as self-contained batteries, or alternatively, the light sources can be connectors which can be used to plug in an external power source. The light ring can be used to illuminate the oral cavity. The light ring can comprise any suitable feature for generating light to illuminate the oral cavity including, but not limited to, light emitting diodes (LEDs), fiberoptic wires, light bulbs, fluorescent or chemiluminescent light sources, or any other suitable light source. The light sources 316, 316' can be connected to an external power supply. Alternatively, the light sources can comprise batteries. FIG. 3C illustrates a side view of the isolated retraction

device 300. In addition to the upper frame 304, the lower frame 306, the tongue retractor 310, lip ring 308, light ring 314, and light sources 316, the device 300 can further comprise a lip rest 318 for providing further retraction of the lip and to facilitate placement of the device. FIG. 3D illustrates a posterior view of the device 300 illustrating the upper frame 304 with gum protection cover 320, the lower frame 306 with gum protection cover 320, portions of the lip ring 308, and the posterior side of the tongue retractor 310.

[0081] FIGS. 4A-4D illustrate the upper gum protection cover 420 and the lower gum protection cover 422 isolated from the retraction device. FIG. 4A is a perspective view of the gum protection covers 420, 422, and the tongue retractor 410. Inlet 412 can be seen in the lower gum protection cover 422. The inlets 412 can provide communication, preferably fluid communication, between the oral cavity and the retraction device. The upper and lower gum protection covers can be rigid. Alternatively, the gum protectors can be soft, pliable membranes. The gum protectors can be made out any suitable material including, but not limited to, rubber, wax, foam, or any other suitable material or combination thereof FIG. 4B is a top view of a retraction device 400, illustrating the upper gum protector 420 and the tongue retractor 410. FIG. 4C illustrates a side view of the gum protection covers, both the upper gum protection cover 420 and the lower gum protection cover 422. FIG. 4C also shows the tongue retractor 410. FIG. 4D illustrates a posterior view of the retraction device 400, illustrating the upper gum protection cover 420 and the lower gum protection cover 422. Inlets 412 for evacuating the oral cavity can be seen in the lower gum protection cover 422.

[0082] In some embodiments, the retraction device 500 is comprised of a frame 502, as shown in FIGS. 5A-5D. The frame 502 can be further comprised of an upper frame 504 and a lower frame 506. The frame can be a malleable frame. It can be shaped to conform to the topology of the patient's oral cavity. In some embodiments, the frame is a wire frame. In some embodiments, the frame is made of a moldable plastic or wax. The frame can be made out of any suitable material for making the frame. Inlets 512 for evacuating the oral cavity can be seen in the lower frame 506. A suction port located on the bottom frame 524 can be used to introduce suction through the inlets 512 in the lower frame 506. FIG. 5A also illustrates a tongue retractor 510. FIG. 5B is a view of the retraction device 500 from the top showing the top frame 504, the bottom frame 506, inlets 512 in the bottom frame, and the tongue retractor 510. FIG. 5C illustrates a side view of the frame 502, illustrating the top and bottom frames, 504, 506, respectively, and a tongue retractor 510. FIG. 5D illustrates a posterior view of the frame 502, showing the top frame 504, the bottom frame 506, and inlets 512 in the bottom frame 506.

[0083] FIGS. 6A-6D illustrate a light ring 614 isolated from the retraction device. The lip ring can be used to retract the cheeks, and lips. FIG. 6A illustrates a posterior perspective view of the light ring. The light ring 614 can have at least one light source 616, 616'. In some embodiments, the light ring can be a single unit with the lip ring. Alternatively, the light ring can be attached to the lip ring if necessary. The light ring 614 can have at least one opening 625 through which the oral cavity can be illuminated. FIG. 6B is a top view of the light ring 614, showing the light sources 616, 616'. FIG. 6C is a side view of the lip ring 614 showing the lip rest 618 and the light source 616. FIG. 6D is a posterior view of the light ring

614. FIG. 6D also shows a lip rest **618**, openings **625**, **625'** in the lip ring for illuminating the oral cavity, and light sources **616**, **616'**.

[0084] FIGS. 7A-7D illustrate an alternative embodiment of a retraction device **700**, wherein the retraction device does not comprise a tongue retractor or gum protection covers. FIG. 7A illustrates a perspective view of a minimalistic retraction device **700** comprising a frame **702**, a lip ring **708** with a light ring **714**. FIG. 7B is a top view of the retraction device **700** illustrating the upper frame **704**, the lower frame **704** comprising at least one inlet **712** for evacuating the oral cavity. The device can comprise more than one inlet. FIG. 7B also illustrates a top view of the lip ring **708** with a light ring **714**, lip rest **718**, and light sources **716**, **716'**. FIG. 7C is a side view of the retraction device **700** illustrating the upper frame **704**, lower frame **706** with at least one inlet **712**, lip ring **708**, light ring **714** with lip rest **718**, and light source **716**. FIG. 7D is a posterior view of the retraction device **700**.

[0085] FIGS. 8A-8D illustrate an alternative embodiment of a retraction device **800** in which the frame is covered by a cover **826**. The frame cover **826** can be a soft membrane material. The frame cover can be made of any suitable material including, but not limited to, rubber, or corn polymers, or "green" or environmentally friendly sustainable materials, or any of the materials previously mentioned. FIG. 8A is a perspective view of the device **800** with a cover **826** covering the entire device. In some embodiments, the cover can cover a portion of the device. The cover can have openings **825** which can fit around the dental surfaces in the oral cavity of the patient. In some embodiments, the opening **825** is a slit. In some embodiments, the opening has a shape similar to the dental arch. FIG. 8B illustrates a top view of the device **800** showing the cover **826** and an opening **825** in the cover **826**. FIG. 8C is a side view of the device **800**. The cover can cover the upper and lower frames of the device, with the space between the upper and lower frames remaining uncovered. Alternatively, the cover can cover the space in between the upper and lower frames as shown in FIG. 8C. FIG. 8D is a posterior view of the device.

[0086] FIGS. 9A-9D illustrate a cover **926** isolated from the retraction device. FIGS. 9A-9D show an isolated cover **926** for both the upper and lower frames.

[0087] FIGS. 10A-10D illustrate a light ring **1014** isolated from the retraction device. FIG. 10A illustrates a front perspective view of an isolated light ring **1014** illustrating the light sources **1016**, **1016'** and the outputs **1015** from the light ring **1014** which can be used to illuminate the oral cavity. The light ring **1014** can also have a lip rest **1018** as shown in FIG. 10A. FIG. 10B is a top view of the light ring **1014**. FIG. 10C is a side view of the light ring **1014**. FIG. 10D is a posterior view of the light ring **1014**. The outputs **1015** from the light ring **1014** can be located in the upper part of the light ring, the lower part of the light ring, and on the sides of the light ring, as shown in FIG. 10D. Alternatively, the outputs **1015** from the light ring **1014** can be located in only the upper portion of the light ring. The light outputs can be located only in the lower portion of the light ring. The light outputs can be located in the sides of the light ring. The light outputs can be grouped together or the light outputs can be uniformly spaced throughout the light ring. The light outputs can be any suitable output for illuminating the oral cavity including, but not limited to, light bulbs, LEDs, fiber optics, or any combination thereof or any other suitable light output.

[0088] FIGS. 11A-11D illustrate an alternate form of a light ring **1114**. In some embodiments, the light ring can be made of a flexible material, as shown in FIGS. 11A-11D. The flexible material allows the light ring to be flexed without damage to the circuit.

[0089] FIGS. 12A-12D illustrate an alternate embodiment of an isolated frame of the retraction device **1200**. The frame design of the invention can provide better access to the palette area for scanning, as previously described. The upper and lower frames also facilitate insertion of a scanning device along the side of the frame. The tissue can be kept away from the teeth so that a powder coating can be applied to the dental surfaces. The mouth can be scanned in its entirety without stopping. FIG. 12A is a perspective view of the device as viewed from the posterior side of the device **1200**. The lip ring **1208**, the upper and lower frames, **1204**, **1206**, respectively, and tongue retractor **1210** can be seen. FIG. 12B is a top view of the device **1200**. FIG. 12C is a side view of the device **1200**. FIG. 12D is a posterior view of the device.

[0090] FIGS. 13A-13D illustrate an alternate embodiment of a retraction device **1300** without a tongue retractor.

[0091] FIGS. 14A-14D illustrate a frame **1402** isolated from a retraction device. The frame can be used alone to retract soft tissue. Alternatively, the frame can be used with other features or components, such as a soft cover for the frame, a light ring, or lip ring. FIG. 14A is perspective view of the frame **1402**. FIG. 14B is a top view of the frame. FIG. 14C is a side view of the frame. FIG. 14D is a view of the posterior side of the frame.

[0092] FIGS. 15A-15D illustrate the frame shown in FIGS. 14A-14D together with an evacuation component. FIG. 15A illustrates the frame **1502** comprising a lip ring **1508**, and upper frame **1504** and a lower frame **1506**, wherein the lower frame has evacuation inlets **1512**. FIG. 15B illustrates a top view of the upper and lower frame, **1504**, **1506**, respectively, the lip ring **1508**, and inlets **1512** in the bottom frame **1506**. FIG. 15C is a side view of the frame **1502** of the device **1500** including upper and lower frames **1504**, **1506**, lip ring **1508**, and inlets located in the lower frame **1506**. FIG. 15D is a posterior view of the retraction device **1500** including upper and lower frame **1504**, **1506**, lip ring **1508**, and inlets **1512** from the evacuation component of the device.

[0093] FIGS. 16A-16D are views of an isolated lip ring. FIG. 16A is a perspective view of the lip ring **1608** from the posterior side of the lip ring. The lip ring can have attachment fittings **1609** for attaching the lip ring **1608** to the frame of the retraction device. FIG. 16B is a top view of the lip ring **1608**. FIG. 16C is a side view of the lip ring **1608**; FIG. 16D is a posterior view of the lip ring **1608**.

[0094] FIGS. 17A-17 are isolated views of a tongue retractor. The tongue retractor can be a wire structure. Alternatively, the tongue retractor can comprise a structure that extends into a volume of space forward from the wire structure. The tongue can occupy the space underneath the tongue retractor cover. The tongue retractor can serve to contain and confine the tongue in a restricted space, thereby preventing the tongue from filling the oral cavity. FIG. 17A is a perspective view of a tongue retractor **1710**. The tongue retractor **1710** can be a simple structure consisting of a wire frame. Alternatively, the tongue retractor **1710** can comprise a cover **1711** for encasing the tongue retractor **1710**. The tongue retractor can contain the tongue from at least one side of the tongue. Alternatively, the tongue retractor can contain the tongue from both sides of the tongue. In some embodiments, the tongue retractor can

confine the tongue in its entirety. The tongue retractor can confine the tongue to a restricted space, thereby preventing the tongue from filling the oral cavity. FIG. 17B is a top view of the tongue retractor 1710. FIG. 17C is a side view of a tongue retractor 1710. FIG. 17D is a posterior view of the tongue retractor 1710.

[0095] In some embodiments, the retraction device can be of the embodiments shown in FIGS. 18A-18D. The retraction device 1800 can further comprise a hinge 1828 that can be used to further alter the shape of the retraction device 1800. In some embodiments, the hinge can be a flexible material hinge. As shown in FIG. 18A, the retraction device 1800 can comprise an upper frame 1804, and a lower frame 1806, and a tongue retractor 1810. The upper and lower frames 1804, 1806, respectively can be in mechanical communication through at least one support 1830. The support can comprise a hinge 1828 for collapsing the upper frame 1804 toward the lower frame 1806. The hinge 1828 can facilitate the compression of the device 1800 to undertake a more compact structure for ease in inserting into the oral cavity. In some embodiments, the hinge can be located in the side supports. In some embodiments, a hinge can be located in the upper frame 1804 or the lower frame 1806 or both the upper and lower frames 1804, 1806. The support can be rigidly affixed to the upper and lower frames. Alternatively, the support 1830 can be a swiveling support 1830 as shown in FIG. 18A. FIG. 18B is a top view of the retraction device 1800, illustrating the top frame 1804, the bottom frame 1806, the tongue retractor 1810, and the side supports 1830. FIG. 18C is a side view of a retraction device 1800, illustrating the top frame 1804, the bottom frame 1806, tongue retractor 1810, side support 1830, and hinge 1828. FIG. 18D is a posterior view of the retraction device 1800.

[0096] FIGS. 19A-19D show an embodiment of the retraction device having a hinge and swivel supports but without a tongue retractor.

[0097] Isolated supports 2030, 2030' are shown in FIGS. 20A-20D. In some embodiments, the supports 2030, 2030' have at least one hinge 2028, 2028'. In some embodiments, the supports comprise multiple hinges. FIG. 20A is a perspective view of the isolated supports 2030, 2030'. FIG. 20B is a top view of the isolated supports 2030, 2030'. FIG. 20C is a side view of one of the supports 2030 with a hinge 2028. FIG. 20D is a posterior view of two isolated supports 2030, 2030' and their respective hinges 2028, 2028'.

[0098] FIGS. 21A-21D illustrate a lower arch retraction device 2100 with lip ring 2108 with light ring 2114, and tongue retractor 2110. The tongue retractor is braced between the upper palate and below the tongue area. The lip ring connects to the bottom of the frame. When present, an evacuation component is then positioned over the top of the lip ring to form a single unit. The lip ring 2118 is held in place by the upper lip in conjunction with the lip rest 2118 and the lower soft tissue anatomy surrounding the area. The device can have a frame covered with a soft membrane cover as shown in FIG. 21A. In some embodiments, suction can be administered to the oral cavity through inlets 2112 in the soft membrane. FIG. 21B is a top view of the retraction device 2100, illustrating the lower frame 2106 with lower gum protection cover 2122, inlets in the lower frame 2106 and lower gum protection cover 2122, and lip ring 2108 with light ring 2114 and light sources 2116, 2116'. FIG. 21C is a side view of the retraction device 2100. FIG. 21D is a posterior view of the retraction device 2100.

[0099] FIGS. 22A-22D illustrate an alternative embodiment of a retraction device 2200 comprising a frame 2206 with gum protector 2222 without a lip ring. FIG. 22A is a perspective view of a retraction device 2200. FIG. 22B is a top view of a retraction device 2200 illustrating a lower frame 2206 with gum protector 2222 with inlets 2212 along the lower frame 2206, and tongue retractor 2210. FIG. 22C is a side view of the retraction device 2200. FIG. 22D is a posterior view of the retraction device 2200.

[0100] FIGS. 23A-23D illustrate a tongue retractor membrane or cover 2311 configuration. FIG. 23A illustrates a perspective view of the tongue retractor 2310 as viewed from the posterior side of the device. FIG. 23B illustrates a top view of the tongue retractor 2311 with cover 2311. FIG. 23C illustrates a side view of the tongue retractor 2310. FIG. 23D is a posterior view of the tongue retractor cover 2310.

[0101] FIGS. 24A-24D illustrate a view of an isolated lower frame 2406 from a lower arch retraction device. In some embodiments, the lower frame comprises at least one inlet 2412 for evacuating the oral cavity. FIG. 24A illustrates a perspective view of the frame 2406. FIG. 24B is a top view of the lower frame 2406. FIG. 24C is a side view of the frame 2406. FIG. 24D is a posterior view of the frame 2406.

[0102] FIGS. 25A-25D illustrate an alternative embodiment of a lower frame retraction device 2500. The device shown in FIGS. 25A-25D illustrate a device that has leverage once positioned in the mouth to hold the bottom arch in position, thereby preventing the tongue from lifting the bottom arch out of position. FIG. 25A is a perspective view of the lower frame retraction device 2500. The retraction device 2500 shown in FIG. 25A does not rely upon the upper palette and the tongue retractor 2510 to stabilize the device 2500. Therefore, the device is less intrusive than other devices and can further facilitate scanning the oral cavity. FIG. 25A also illustrates a device 2500 having a lower frame 2506 with gum protection cover 2522 with an opening 2525 for the dental arch. The device can also have a lip ring 2508 with a light ring 2514 and lip rest 2518. FIG. 25B illustrates a top view of the device 2500. FIG. 25C illustrates a side view of the device 2500. FIG. 25D illustrates a posterior view of the device 2500.

[0103] An alternate embodiment of a lower arch retraction device 2600 is shown in FIGS. 26A-26D. FIG. 26A illustrates a lower frame 2606 with a gum cover 2622, and a tongue retractor 2610. An opening 2625 for the dental arch is shown in FIG. 26A. Furthermore, a suction port 2624 can connect the retraction device 2600 to a source of suction to evacuate the oral cavity through at least one inlet 2612 located in the frame or gum protector or both. FIG. 26B is a top view of the retraction device showing the suction port 2624 and inlets 2612 in communication, preferably fluid communication, with the suction port 2624, the lower frame 2606 and gum protection cover 2622, tongue retractor 2610, and the opening 2625 for the dental arch in the retraction device 2600. FIG. 26C is a side view of a retraction device 2600 illustrating the frame 2606, the gum protection cover 2622, the tongue retractor 2610, and suction port 2624. FIG. 26D is a posterior view of the retraction device 2600.

[0104] FIGS. 27A-27D illustrate an alternate embodiment of an isolated lower arch retraction device 2700. FIG. 27A illustrates a retraction device 2700 comprising an alternate embodiment of a lip ring 2708, an upper frame 2704, a lower frame 2706, and a tongue retractor 2710. The retraction device 2700 also has a posterior balancing positional support

2732 which aids in the insertion of the device into the oral cavity and provides posterior balancing positional support. The posterior balancing positional supports **2732** contact the back of the cheeks to balance forces from the front of the cheeks in order to properly center the device along the posterior/anterior axis. FIG. **27B** is a top view of the retraction device **2700** illustrating the lip ring, **2708**, lower frame **2706**, tongue retractor **2710**, and posterior supports **2732**. FIG. **27C** is a side view of the retraction device, showing the lip ring **2708**, lower frame **2706**, tongue retractor **2710**, and posterior supports **2732**. FIG. **27D** is a frontal view of the retraction device **2700** illustrating the lip ring **2708**, lower arch frame **2706**, tongue retractor **2710**, and posterior supports **2732**.

[**0105**] FIGS. **28A-28D** illustrate an isolated evacuation element **2834**. FIG. **28A** is a perspective view of an evacuation element **2834** as viewed from the posterior side. The evacuation element can be in communication with a suction source through the suction port **2824**. The evacuation element **2834** can be used to evacuate the oral cavity through at least one inlet **2812** located in the evacuation element **2834**. In some embodiments, multiple evacuation elements **2812** can be located along the length of the evacuation element, as shown in FIG. **28A**. In some embodiments, inlets **2812** can be located along the interior of the cheeks. In some embodiments, inlets **2812** can be located around the tongue. Inlets **2812** can be located along both the cheeks and the tongue. FIG. **28B** is a top view of the evacuation element. FIG. **28C** is a side view of the evacuation element **2834**. FIG. **28D** is a posterior view of the evacuation element **2834**.

[**0106**] FIGS. **29A-29D** illustrate an isolated tongue deflection cover **2911**. The tongue deflection cover can be used to deflect the tongue out of the working space to facilitate scanning the dental surfaces. FIG. **29A** illustrates a perspective view of the tongue deflection cover **2911** as viewed from the posterior side. FIG. **29B** illustrates a top view of the tongue deflection cover **2911**. FIG. **29C** illustrates a side view of a tongue deflection cover. FIG. **29D** illustrates a posterior view of the tongue deflection cover.

[**0107**] FIGS. **30A-30D** illustrate an isolated upper arch frame **3004**. The upper arch frame **3004** can be used in conjunction with a lower arch retraction device. The upper arch frame **3004** can be used to provide optional support for upper retraction of the soft tissue in the oral cavity. FIG. **30A** illustrates one embodiment of an upper arch frame **3004**. The arch support can comprise connectors **3036** to connect the upper arch frame **3004** to the retraction device. The upper arch frame **3004** can be connected to the lower retraction device by snapping the upper arch frame **3004** and the lower retraction device together. Alternatively, the upper arch frame **3004** can be connected to the lower retraction device by screwing the pieces together. Alternatively, the upper arch frame can be adhered to the lower retraction device by any suitable adhesive or mechanism for adhering the two units together including but not limited to, glue, tape, rubber bands, or any combination thereof. FIG. **30B** is a top view of an isolated upper arch frame **3004**. FIG. **30C** is a side view of an upper arch frame. FIG. **30D** is a posterior view of an upper arch frame.

[**0108**] FIGS. **31A-31D** illustrate an alternative embodiments of an isolated upper arch retraction device **3100** including a lip ring **3108**. In some embodiments, the retraction device is a single piece. In some embodiments, the retraction device **3100** can be more than one piece, where the pieces are assembled prior to inserting the device into the oral cavity. The lip ring can be attached to the frame at the posterior end

of the device **3100**. FIG. **31A** is a perspective view of upper arch retraction device **3100** having a lip ring **3108**, upper arch frame **3104**, and tongue retractor **3110**. In some embodiments, the device **3100** further comprises a tongue cover for containing the tongue. FIG. **31B** is a top view of the retraction device **3100**, illustrating the upper arch frame **3104**, lip ring **3108**, and tongue retractor **3110**. FIG. **31C** is a side view of the retraction device **3100**. FIG. **31D** is a frontal view of the retraction device **3100**.

[**0109**] FIGS. **32A-32D** illustrate an alternative embodiment of a retraction device **3200**. In this embodiment, the upper retraction frame **3204** is separated by a gap **3238**. In some embodiments, the lip ring can have a gap **3238**. In some embodiments, both the upper frame **3204** and the lip ring **3208** have a gap **3238**, as shown in FIG. **32A**. The device can have a tongue retractor **3210**. FIG. **32B** is a top view of a retraction device **3200** with a gap **3238**. FIG. **32C** illustrates a side view of a retraction device **3200**. FIG. **32D** illustrates a front view of the retraction device **3200**.

II. Methods

[**0110**] Further provided herein are methods of use of the invention described herein. Provided herein is a method of retracting tissue in an oral cavity comprising: inserting a retraction device comprising a topology conformable structure adaptable to be in a constrained shape that can be delivered into an oral cavity and further adaptable to be in an unconstrained shape to create a useable working field in the oral cavity, the useable working field providing increased accessibility to and increased visibility within the oral cavity; and positioning the retraction device in the oral cavity to create an isolated working field. The positioning step can be performed in less than 1 minute. In some embodiments, the positioning step can be performed in less than 20 seconds.

[**0111**] Yet another method for retracting tissue in an oral cavity comprises: inserting a retraction device comprising a topology conformable structure adaptable to create a working field in an oral cavity of a patient, wherein the working field is at least 10% larger than a working field in oral cavity of the patient without use of the device; and positioning the retraction device in the oral cavity to create an isolated working field.

[**0112**] Another method provided herein is a method of facilitating the creation of an oral cavity model comprising: inserting a retraction device comprising a topology conformable structure adaptable to be in a constrained shape that can be delivered into an oral cavity and further adaptable to be in an unconstrained shape to create a useable working field in the oral cavity, the usable working field providing increased accessibility to and increased visibility within the oral cavity; and positioning the retraction device in the oral cavity to create the useable working field in the oral cavity. In some embodiments, the method can further comprise the step of illuminating the oral cavity with the retraction device. Additionally, the method can comprise the step of applying a powder to the at least one dry tooth surface.

III. Materials Of Manufacture

[**0113**] As will be appreciated by those skilled in the art, the devices described herein, and other device designs that can be employed under the invention based on the teachings herein, and their components can be made from a variety of materials known in the art. Candidate materials for the devices and

components would be known by persons skilled in the art and include, for example, the materials described above as well as suitable biocompatible materials such as metals (e.g. stainless steel, shape memory alloys, such as nickel titanium alloy nitinol) and engineering plastics (e.g. polycarbonate). See, for example U.S. Pat. No. 5,190,546 to Jervis for Medical Devices Incorporating SIM Memory Alloy Elements and U.S. Pat. No. 5,964,770 to Flomenblit for High Strength Medical Devices of Shape Memory Alloy. For example, a device frame may be made of materials such as titanium, cobalt chrome stainless steel. Alternatively, a sheath or outer layer covering a frame can be made of biocompatible polymers such as polyetheretherketone (PEEK), polyarylamide, polyethylene, and polysulphone. See, for example U.S. Pat. No. 5,190,546 to Jervis for Medical Devices Incorporating SIM Memory Alloy Elements and U.S. Pat. No. 5,964,770 to Flomenblit for High Strength Medical Devices of Shape Memory Alloy. Other materials may be appropriate for some or all of the components, such as biocompatible polymers, including polyetheretherketone (PEEK), polyarylamide, polyethylene, and polysulphone. U.S. Pat. No. 5,964,770 to Flomenblit for High Strength Medical Devices of Shape Memory Alloy.

[0114] A variety of hydrophilic materials, hydrophobic materials, or putties can also be used, e.g. to form seals. Such materials would be known to a person skilled in the art and include, for example, hydrophilic material or a putty (e.g., Van-R reversible hydrocolloid, available from Dux Dental, and vinyl polysiloxane, available from 3M Express), as discussed above. Other materials that might also be used include, for example, poly(vinyl alcohol) (PVA) hydrogels, hydrophilic, medical grade foam, polysaccharides, glucosaminoglycans. Additional materials can include, silicones, thermal plastic elastomers (TPE), thermal plastic urethanes (TPU), nylons and material, epoxys, corn polymers or other environmentally friendly materials, or any combination thereof. The material can also be any suitable biocompatible material.

[0115] In some embodiments, the device can be constructed from materials having different properties. In some embodiments, the devices described herein can be created from single property membrane transformed into multiple properties. The material can harden through additional processes, such as by changing the molecular structure of the material. In some embodiments, the material can be placed over a frame or device. The material can then undergo a process that can change the material properties of the material. In some embodiments the material property of the device is the same throughout. Alternatively, the device can be comprised of material having different properties. For example, the material of the device can be harder or stiffer in some areas and softer in other areas. The properties of the material can be changed using a laser. Alternatively, the properties of the material can be changed using light. The properties of the material can be changed using any suitable method for altering the material characteristics of the material including, but not limited to, temperature and pH, laser curing, stereolithographic laser polymerization and crosslinking, optical post manufacturing processing, and chemical post manufacturing processing, or any combination thereof.

IV. Kits

[0116] The invention also contemplates a kit comprising one or more devices with one or more device products asso-

ciated with a particular dental treatment. For example, lasers are currently used in dentistry for various applications including but not limited to: cavity removal, cutting or hardening bonding material, whitening teeth, and re-contouring, reshaping, or removing gum tissue. The device herein can be used in combination with laser therapy to act as a shield and tongue and cheek retractor, preventing other regions of the mouth from being affected by the laser. Thus compounds used with the laser procedure could be provided in the kit with the devices or devices, as well as equipment adaptors, etc.

[0117] Additionally, a kit comprising one or more devices with one or more complementary automatic impression tray system(s) or implant specific impression tray(s), which are designed to fit over the upper and/or lower arches of teeth, to capture a detailed and accurate impression of each full arch of teeth and the surrounding alveolar process and gingiva, which the device is in place. This prevents any contamination of the impression(s) with saliva and prevents any escape of impression materials into the mouth cavity or the patient's throat.

[0118] Further provided herein are kits for retracting tissue in an oral cavity. Provided herein are kits for retracting tissue in an oral cavity comprising: a topology conformable structure adaptable to be in a constrained shape that can be delivered into an oral cavity and further adaptable to be in an unconstrained shape to create a useable working field in the oral cavity, the useable working field providing increased accessibility to and increased visibility within the oral cavity. In some embodiments, the kit can further comprise a tongue retractor. Additionally, the kit can further comprise a light ring. Furthermore, the kit can comprise an evacuation component. The kit can further comprise a membrane adaptable to be fitted over the frame. In some embodiments, the kit can further comprise a gum protection cover. The kit can also further comprise a lip ring.

[0119] Furthermore, additionally provided herein is a kit for retracting tissue in an oral cavity comprising: a retraction device comprising a topology conformable structure adaptable to be in a constrained shape that can be delivered into an oral cavity and further adaptable to be in an unconstrained shape to create a useable working field in the oral cavity, the useable working field providing increased accessibility to and increased visibility within the oral cavity; and a kit of secondary dental products wherein tissue retraction in the oral cavity is necessary. In some embodiments, the kit can further comprise an illumination source. Additionally, the kit can comprise at least one optical scanner or digital scanner. Furthermore, the kit can further comprise a powder for facilitate scanning of the dental surfaces. In some embodiments, the kit can further comprise a whitening or bleaching kit.

[0120] While preferred embodiments of the present invention have been shown and described herein, it will be obvious to those skilled in the art that such embodiments are provided by way of example only. Numerous variations, changes, and substitutions will now occur to those skilled in the art without departing from the invention. It should be understood that various alternatives to the embodiments of the invention described herein may be employed in practicing the invention. It is intended that the following claims define the scope of the invention and that methods and structures within the scope of these claims and their equivalents be covered thereby.

What is claimed is:

1. A retraction device comprising a topology conformable structure adaptable to be in a constrained shape that can be

delivered into an oral cavity and further adaptable to be in an unconstrained shape to create a useable working field in the oral cavity, the useable working field providing increased accessibility and increased visibility within the oral cavity.

2. The device of claim 1 wherein the conformable structure is a frame.

3. The device of claim 2 wherein the conformable structure further comprises a membrane.

4. The device of claim 1 further comprising a light source.

5. The device of claim 1 wherein the device is adaptable to be deployed in under 1 minute.

6. The device of claim 1 wherein the device is adaptable to create a working field in under 1 minute.

7. The device of claim 1 wherein the device is adaptable to be deployed in less than 20 seconds.

8. The device of claim 1 further comprising a tongue retractor.

9. The device of claim 8 wherein the tongue retractor is further adaptable to contain and confine the tongue.

10. The device of claim 8 wherein the tongue retractor is adaptable to deflect the tongue without passing over either arch of teeth.

11. The device of claim 1 further comprising at least one evacuation component.

12. The device of claim 1 wherein the device is adaptable to retract soft tissue surrounding at least one arch of teeth.

13. The device of claim 1 wherein the device is adaptable to retract soft tissue surrounding an upper arch of teeth and a lower arch of teeth.

14. The device of claim 1 wherein the device is further adaptable to isolate at least a portion of gum tissue located in the oral cavity.

15. The device of claim 1 further comprising at least one aperture to facilitate the ability to breathe through the device.

16. The device of claim 1 wherein the scanning comprises at least one of digital scanning or optical scanning.

17. The device of claim 1 wherein the device is adaptable to isolate both arches of teeth is less than 20 seconds.

18. The device of claim 1 wherein the device is adaptable to be positioned without interfering with access to dental surfaces and further adaptable to provide maximum patient comfort.

19. A retraction device comprising a topology conformable structure adaptable to create a working field in an oral cavity of a patient, wherein the working field is at least 10% larger than a working field created in the oral cavity of the patient without use of the device.

20. The device of claim 19 wherein the device is adaptable to provide at least 10% more access to an area of interest in the oral cavity.

21. The device of claim 19 wherein the device is adaptable to provide at least 10% more visibility within the oral cavity.

22. The device of claim 19 wherein the device is adaptable to provide at least 10% less contamination of structures located in the oral cavity by fluid.

23. The device of claim 19 wherein the device is adaptable to provide at least 10% less interference by soft tissue located in the oral cavity.

24. The device of claim 19 wherein the conformable structure is a frame.

25. The device of claim 19 further comprising a membrane.

26. The device of claim 19 further comprising a light source.

27. The device of claim 19 wherein the device is adaptable to isolate at least one arch located in the oral cavity.

28. The device of claim 19 wherein the device is adaptable to isolate an upper arch and a lower arch located in the oral cavity.

29. The device of claim 19 wherein the device is adaptable to isolate at least a portion of gum tissue in the oral cavity.

30. The device of claim 19 wherein the device is adaptable to be deployed in under 1 minute.

31. The device of claim 30 wherein the device is adaptable to create a working field in under 1 minute.

32. The device of claim 30 wherein the device is adaptable to be deployed in under 20 seconds.

33. The device of claim 30 wherein the device requires no further adjustment after being deployed.

34. The device of claim 19 further comprising a tongue retractor.

35. The device of claim 34 wherein the tongue retractor is adaptable to contain and confine the tongue.

36. The device of claim 34 wherein the tongue retractor is adaptable to allow a first occlusal surface and a second occlusal surface to touch.

37. The device of claim 34 wherein the tongue retractor is adaptable to compress at least one side of the tongue.

38. The device of claim 34 wherein the tongue retractor is adaptable to compress both sides of the tongue.

39. The device of claim 19 further adaptable to apply suction to the oral cavity.

40. The device of claim 19 further comprising at least one aperture adaptable to facilitate the ability to breathe through the device.

41. The device of claim 19 wherein the device is adaptable to at least one dental arch in less than 20 seconds.

42. The device of claim 19 wherein the device is adaptable to be positioned without interfering with access to dental surfaces and further adaptable to provide maximum patient comfort.

43. A retraction device comprising a malleable frame adaptable to be in a constrained shape that can be delivered into an oral cavity and further adaptable to be in an unconstrained shape to isolate at least one arch of teeth from saliva and soft tissue surrounding the arch.

44. The device of claim 43 wherein the malleable frame is a wire frame.

45. The device of claim 44 wherein the malleable frame further comprises a membrane.

46. The device of claim 43 further comprising a light source.

47. The device of claim 43 wherein the device is adaptable to be deployed in under 1 minute.

48. The device of claim 43 wherein the device is adaptable to be deployed in under 20 seconds.

49. The device of claim 43 wherein the device is adaptable to create a working field in under 1 minute.

50. The device of claim 43 further comprising a tongue retractor.

51. The device of claim 50 wherein the tongue retractor is further adaptable to contain and confine the tongue.

52. The device of claim 50 wherein the tongue retractor is adaptable to allow a first occlusal surface and a second occlusal surface to touch.

53. The device of claim 43 further comprising at least one evacuation component.

54. The device of claim 43 wherein the device is adaptable to retract soft tissue surrounding at least one arch of teeth.

55. The device of claim 43 wherein the device is adaptable to retract soft tissue surrounding an upper arch of teeth and a lower arch of teeth.

56. The device of claim 43 wherein the device is further adaptable to isolate at least a portion of gum tissue located in the oral cavity.

57. The device of claim 43 further comprising at least one aperture to facilitate the ability to breathe through the device.

58. The device of claim 43 wherein the device is further adaptable to facilitate the application of a substance to at least one tooth surface.

59. The device of claim 43 wherein the substance is a powder.

60. The device of claim 43 wherein the device is adaptable to isolate at least one dental arch in less than 20 seconds.

61. The device of claim 43 wherein the device is adaptable to create a working field without interfering with access to dental surfaces.

62. The device of claim 43 wherein the device is adaptable to be positioned in the mouth with maximum patient comfort.

63. A method of retracting tissue in an oral cavity comprising:

inserting a retraction device comprising a topology conformable structure adaptable to be in a constrained shape that can be delivered into an oral cavity and further adaptable to be in an unconstrained shape to create a useable working field in the oral cavity, the useable working field providing increased accessibility and increased visibility within the oral cavity; and positioning the retraction device in the oral cavity to create the working field.

64. The method of claim 63 wherein the positioning step is performed in less than 1 minutes.

65. The method of claim 63 wherein the positioning step is performed in less than 20 seconds.

66. A method of retracting tissue in an oral cavity comprising:

inserting a retraction device comprising a topology conformable structure adaptable to create a working field in an oral cavity of a patient, wherein the working field is at least 10% larger than a working field in oral cavity of the patient without use of the device; and positioning the retraction device in the oral cavity to create an isolated working field.

67. A method of facilitating the creation of an oral cavity model comprising:

inserting a retraction device comprising a topology conformable structure adaptable to be in a constrained shape that can be delivered into an oral cavity and further adaptable to be in an unconstrained shape to create a useable working field in the oral cavity, the useable working field providing increased accessibility and increased visibility within the oral cavity; and positioning the retraction device in the oral cavity to create the useable working field in the oral cavity.

68. The method of claim 67 further comprising the step of illuminating the oral cavity with the retraction device.

69. The method of claim 67 further comprising the step of applying a powder to the at least one dry tooth surface.

70. A kit for retracting tissue in an oral cavity comprising: a topology conformable structure adaptable to be in a constrained shape that can be delivered into an oral cavity and further adaptable to be in an unconstrained shape to create a useable working field in the oral cavity, the useable working field providing increased accessibility and increased visibility within the oral cavity.

71. The kit of claim 70 further comprising a tongue retractor.

72. The kit of claim 70 further comprising a light ring.

73. The kit of claim 70 further comprising an evacuation component.

74. The kit of claim 70 further comprising a membrane adaptable to be fitted over the frame.

75. The kit of claim 70 further comprising a gum protection cover.

76. The kit of claim 70 further comprising a lip ring.

77. A kit for retracting tissue in an oral cavity comprising: a topology conformable structure adaptable to be in a constrained shape that can be delivered into an oral cavity and further adaptable to be in an unconstrained shape to create a useable working field in the oral cavity, the useable working field providing increased accessibility and increased visibility within the oral cavity; and a kit of secondary dental products wherein tissue retraction in the oral cavity is necessary.

78. The kit of claim 77 further comprising an illumination source.

79. The kit of claim 77 further comprising at least one of an optical scanner or digital scanner.

80. The kit of claim 77 further comprising a powder.

81. The kit of claim 77 further comprising a whitening or bleaching kit.

* * * * *