



- (51) International Patent Classification:
E04G 11/48 (2006.01) *E04G 1/14* (2006.01)
- (21) International Application Number:
PCT/AU2013/000855
- (22) International Filing Date:
2 August 2013 (02.08.2013)
- (25) Filing Language: English
- (26) Publication Language: English
- (30) Priority Data:
2012903312 2 August 2012 (02.08.2012) AU
- (71) Applicant: FORM 700 PTY LTD [AU/AU]; 270 Blackshaws Road, Altona North, Victoria 3025 (AU).
- (72) Inventor: ROSATI, Emilio; 20 Devonshire Road, Rossmore, NSW 2171 (AU).
- (74) Agent: MADDERN'S; GPO Box 2752, Adelaide, South Australia 5001 (AU).
- (81) Designated States (unless otherwise indicated, for every kind of national protection available): AE, AG, AL, AM,

AO, AT, AU, AZ, BA, BB, BG, BH, BN, BR, BW, BY, BZ, CA, CH, CL, CN, CO, CR, CU, CZ, DE, DK, DM, DO, DZ, EC, EE, EG, ES, FI, GB, GD, GE, GH, GM, GT, HN, HR, HU, ID, IL, IN, IS, JP, KE, KG, KN, KP, KR, KZ, LA, LC, LK, LR, LS, LT, LU, LY, MA, MD, ME, MG, MK, MN, MW, MX, MY, MZ, NA, NG, NI, NO, NZ, OM, PA, PE, PG, PH, PL, PT, QA, RO, RS, RU, RW, SC, SD, SE, SG, SK, SL, SM, ST, SV, SY, TH, TJ, TM, TN, TR, TT, TZ, UA, UG, US, UZ, VC, VN, ZA, ZM, ZW.

(84) Designated States (unless otherwise indicated, for every kind of regional protection available): ARIPO (BW, GH, GM, KE, LR, LS, MW, MZ, NA, RW, SD, SL, SZ, TZ, UG, ZM, ZW), Eurasian (AM, AZ, BY, KG, KZ, RU, TJ, TM), European (AL, AT, BE, BG, CH, CY, CZ, DE, DK, EE, ES, FI, FR, GB, GR, HR, HU, IE, IS, IT, LT, LU, LV, MC, MK, MT, NL, NO, PL, PT, RO, RS, SE, SI, SK, SM, TR), OAPI (BF, BJ, CF, CG, CI, CM, GA, GN, GQ, GW, KM, ML, MR, NE, SN, TD, TG).

Published:
— with international search report (Art. 21(3))

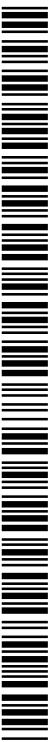

WO 2014/019029 A1

(54) Title: FORMWORK SUPPORT ELEMENT

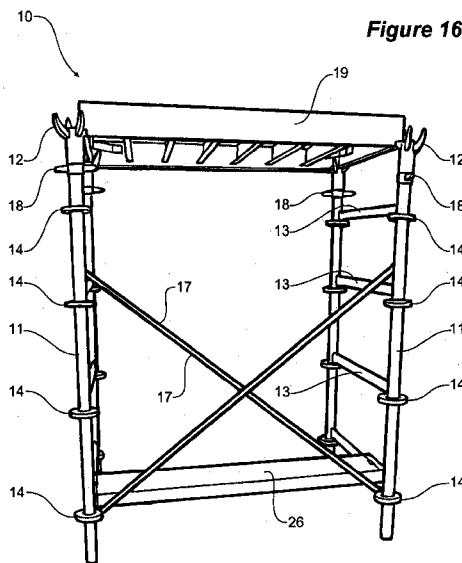

(57) Abstract: This invention relates to a formwork support member, and a scaffold structure formed from at least a pair of adjacent formwork support members. The formwork support member comprises at least two spaced vertical members, at least one connecting member bridging said vertical members to form thereby a rigid formwork support member, each vertical member including a plurality of attachment means at spaced intervals there- along for releasable attachment thereto of at least one brace member extending between adjacent formwork support members to form the scaffold structure.

FORMWORK SUPPORT ELEMENT

PRIORITY DOCUMENTS

[0001] The present application claims priority from:

Australian Provisional Patent Application No 2012903312 titled "FORMWORK SUPPORT ELEMENT" and filed on 2 August 2012;

The content of this application is hereby incorporated by reference in its entirety.

TECHNICAL FIELD

[0002] This invention relates to a formwork support element used to form a rigid scaffolding structure for supporting formwork for concrete casting purposes.

BACKGROUND

[0003] Formwork is used in concrete construction to provide a mould or a surface onto which wet concrete can be poured for forming various elements such as floor slabs and beams for example. In the case of floor slabs, it is common for floors of a multi-story building to be formed sequentially and for formwork to be set out on a preceding floor in order to form the subsequent higher floor.

[0004] Such formwork normally comprises a frame or scaffolding that are used to support elevated forms comprising either lost formwork or formwork that can be removed from the concrete slab once the concrete is set. Reusable formwork may comprise aluminium formwork pans which are held at the top of the scaffolding. In addition, sheets or boards may also be used at the top of the framework.

[0005] The aluminium formwork pans are normally rectangular in plan form and have lips or edges extending downwardly from the formwork surface. These aluminium pans can be supported in forks which comprise of four upwardly directed fingers extending from a single vertical support which hold a corner each of four adjoining aluminium pans.

[0006] Normally, the scaffolding used to support the formwork is manually assembled from a number of discreet elements. These discreet elements include vertical tubular supports and bracing members which extend between adjacent vertical supports. It is common to provide a scaffold structure comprising four spaced vertical supports arranged in a rectangular plan form with a vertical support at each corner with the necessary bracing between the four vertical supports to hold each of the vertical supports upright. A

fork is placed at the top of each vertical support with a screw jack in order to adjust the height of the fork prior to the aluminium formwork pans being put in place.

[0007] Each individual scaffold structure is spaced from adjacent scaffold structures by the width of the aluminium formwork pans so that a single formwork pan can bridge between each scaffold structure.

[0008] The construction of each scaffold structure is extremely labour intensive, time consuming and requires a number of workers to hold each individual vertical support upright while the brace members are attached between individual vertical members so as to form a self-supporting structure.

[0009] It is against this background and the problems and difficulties associated therewith that the present invention has been developed.

[0010] Certain objects and advantages of the present invention will become apparent from the following description, taken in connection with the accompanying drawings, wherein, by way of illustration and example, an embodiment of the present invention is disclosed.

SUMMARY

[0011] According to a first aspect, there is provided a formwork support member comprising at least two spaced vertical members, at least one connecting member bridging said vertical members, each vertical member including a plurality of attachment means at spaced intervals there-along for releasable attachment thereto of at least one brace member extending between adjacent formwork support members to form a rigid structure.

[0012] Preferably, the formwork support member according to the above description is in a planar form but it may also include bracing members at an angle in a horizontal plane with respect to a first set of bracing members where three or more spaced vertical members are used. The connecting members may be releasable attached to each vertical member at their respective ends provided that such attachment forms a formwork support member having sufficient rigidity to be raised into a vertical position without significant relative movement between the vertical members and the connecting members. Preferably, the connecting members are welded to the vertical members, and further, the connecting members preferably positioned horizontally between the vertical members when the vertical members are in an upright position.

[0013] The attachment means on each vertical member enable releasable attachment of brace members between adjacent formwork support members. Preferably, a pair of formwork support members are

secured to one another by diagonal braces which extend from a lower attachment means positioned on one formwork support member to an upper attachment means on an adjacent formwork support member. Preferably, four diagonal braces are used between a pair of formwork support members to form a scaffold structure.

[0014] Horizontal brace members may extend between adjacent scaffold structures with each horizontal brace member attaching at either end to an attachment means on adjacent vertical members. This provides a means of holding each scaffold structure the correct distance apart for the reason that will be described below.

[0015] The upper end of each vertical member may support a fork and each fork may have a jacking extension comprising a screw threaded portion with a rotatable collar against which the base of the fork abuts to enable the fork to be raised or lowered to the required position. The fork has four projecting fingers, each finger being for supporting the corner of an aluminium formwork pan.

[0016] Alternatively, the upper end of each vertical member may be used to support a second formwork support member where each vertical member is attached to an adjacent lower vertical member of the lower formwork support member. A dowel is inserted into the upper end of each vertical member and also locates into the lower end of the upper vertical member. Brace members are used between the upper formwork support members to form a rigid structure.

[0017] In the case of formwork support structures comprising a number of stacked formwork support members, another aspect of the invention is the placement of deck elements between adjacent formwork support members to form an elevated working surface to enable easier access to the upper portions of the formwork support members for locating a second formwork support member on top of a lower support member. The deck elements have a panel with u-shaped connectors at either end where the u-shaped connectors locate over the upper surface of a horizontal brace member. This enables deck elements to be quickly positioned at a required height between adjacent formwork support members. Deck elements may also be used on single height formwork support members to enable location of formwork on the upper end.

[0018] Preferably, the first level of scaffold structures are assembled on a surface with the decking elements then being located within and between each of the scaffold structures. This then forms a continuous working surface across the assembly of the scaffold structures which then provides a very safe working environment for further construction of the scaffolding structure.

[0019] In an alternative, the attachment means comprise a number of u-shaped metal strips that are welded to each vertical member at locations spaced along each vertical member.

[0020] In a further aspect, the invention may be said to reside in a formwork support member comprising at least two spaced vertical members, a plurality of connecting members being attached at either end to one of said vertical members to form thereby a rigid formwork support member, and further including a plurality of attachment means at spaced intervals along each vertical member comprising a means for releasably attaching a plurality of brace members between individual adjacent formwork support member or members to form a rigid structure.

[0021] In a further aspect, the invention may be said to reside in a scaffold structure comprising at least a pair of adjacent formwork support members, each formwork support member comprising at least two spaced vertical members, at least one connecting members bridging said vertical members to form thereby a rigid formwork support member, each vertical member including a plurality of attachment means at spaced intervals there-along, the scaffold structure further comprising at least one brace member extending between and releasably attached at each end thereof to the adjacent formwork support members.

[0022] In yet a further aspect, the invention may be said to reside in an assembly of at least a pair of the above described scaffold structures, where these are bridged by at least one brace member releasably attached at each end thereof to the scaffold structures.

[0023] In yet a further aspect, the invention may be said to reside in a formwork support member comprising a single vertical member, and a plurality of attachment means at spaced intervals there-along for releasable attachment thereto of at least one brace member extending between adjacent formwork support members to form a rigid structure.

[0024] A detailed description of one or more embodiments of the invention is provided below along with accompanying figures and photographs that illustrate by way of example the principals of the invention. While the invention is described in connection with such embodiments, it should be understood that the invention is not limited to any particular embodiment. On the contrary, the scope of the invention is limited only by the appended claims and the invention encompasses numerous alternatives, modifications and equivalents. For the purpose of example, numerous specific details are set forth in the following description in order to provide a thorough understanding of the present invention.

[0025] The present invention may be practiced according to the claim without some or all of the specific details. For the purpose of clarity, technical material is known in technical fields related to the invention has not been described in detail so that the present invention is not unnecessarily obscured.

BRIEF DESCRIPTION OF DRAWINGS

[0026] Embodiments of the present invention will be discussed with reference to the accompanying drawings wherein:

[0027] Figure 1 is an end view of a scaffold structure according to a first embodiment;

[0028] Figure 2 is a side view of the scaffold structure of Figure 1;

[0029] Figure 3 is a schematic representation of the scaffold structure of Figure 1 in plan view;

[0030] Figure 4 is an end view of a scaffold structure according to a second embodiment;

[0031] Figure 5 is a side view of the scaffold structure of Figure 4;

[0032] Figure 6 is a schematic representation of the scaffold structure of Figure 4 in plan view;

[0033] Figure 7 is an end view of a scaffold structure according to a third embodiment;

[0034] Figure 8 is a side view of the scaffold structure of Figure 7;

[0035] Figure 9 is a schematic representation of the scaffold structure of Figure 7 in plan view;

[0036] Figure 10 is a cross-sectional view taken at 1-1 of Figure 1, and detailing attachment means;

[0037] Figure 11 is an end view of an assembly of scaffold structures;

[0038] Figure 12 is a side view of the assembly of Figure 11;

[0039] Figure 13 is a schematic representation of the assembly of scaffold structures of Figure 11 in plan view;

[0040] Figure 14 is an end view of the assembly of Figure 11, further comprising decking members;

[0041] Figure 15 is a side view of the assembly of Figure 11, further comprising decking members;

[0042] Figure 16 is a perspective view of the scaffold structure of Figure 4;

[0043] Figure 17 is a perspective view of an assembly of scaffold structures; and

[0044] Figure 18 is a detail view of an attachment point between a brace member and a pair of vertical supports.

[0045] In the following description, like reference characters designate like or corresponding parts throughout the figures.

DESCRIPTION OF EMBODIMENTS

[0046] Referring now to Figures 1 through 9 and 16, where there is shown in each case a scaffold structure 10 each having a common width of 903mm and a common depth of 1800mm, but differing heights.

[0047] Each scaffold structure 10 comprises two formwork support members 1, where each formwork support member 1 comprises two spaced vertical members 11, and a pair of horizontal connecting members 13 extending between and welded to the vertical members 11. This combination of the vertical members 11 and connecting members 13 forms a rigid formwork support member 1.

[0048] Each of the vertical members illustrated in Figures 1 through 9 includes a plurality of attachment means 14 at spaced intervals there-along, and a fork 12 at the upper end thereof. Each fork 12 is supported on a jacking extension comprising a screw threaded portion with a rotatable collar 18 against which the base of the fork 12 abuts to enable the fork to be raised or lowered to the required position.

[0049] The attachment means 14 take the form of locking rings 14 for releasable attachment thereto of at least one brace member (diagonal and/or horizontal) extending between adjacent formwork support members 1 to form a rigid scaffold structure 10.

[0050] With reference to Figure 10, it can be seen that each locking ring 14 has an inner diameter which equals the outer diameter of the vertical members 11 so that each locking ring 14 can be slid into position prior to fixing by welding. Each locking ring 14 comprises eight (8) single apertures 15 equally spaced around the locking ring 14. In this way, the ends of multiple brace members can be attached thereto, with these brace members extending at various angles as required.

[0051] In addition to a number of locking rings 14 spaced along each vertical member 11, each vertical member 11 has a pair of latch pins 16 that are used for securing a diagonal brace 17, although diagonal braces 17 could be attached via locking rings 14. Each latch pin 16 comprises a pin secured to the vertical members 11 with a movable gravity pin located at its end. The gravity pin can be held in a horizontal position parallel to the main pin to make it easy to attach the diagonal brace 17 whereupon once the diagonal brace 17 is located on the pin, the gravity pin can be moved from its horizontal position where it drops to a vertical position to thereby prevent release of the diagonal brace 17. Each diagonal brace 17 has a pin aperture at each end which enables rapid attachment of the diagonal braces between adjacent formwork support members.

[0052] In order to assemble a scaffold structure 10 like that illustrated in Figure 16, a pair of formwork support members 1 are held in a vertical position and a diagonal brace 17 is attached to a lower latch pin 16 on one of the formwork support members 1, and is then attached to an upper latch pin 16 on the adjacent formwork support member 1. In this way, four diagonal braces 17 extend between a pair of formwork support members 1 to thereby form a scaffold structure 10.

[0053] Figures 1 and 16 also show an aluminium formwork pan 19 sitting on the four forks 12 of the scaffold structure 10. The pan 19 uses one finger from each of the four forks 12 on the scaffold structure 10.

[0054] Referring now to Figures 11 and 12, where there is illustrated an assembly of scaffold structures 10, where additional formwork support members 21 are positioned adjacent to the scaffold structures 10 and held in place by horizontal brace members 22 and additional diagonal members 23. These additional formwork support members 21 comprise a single vertical member 11 supporting locking rings 14 and one fork 12.

[0055] With reference to Figure 18, it can be seen that the brace members 22 and 23 are secured at each end to a respective aperture 15 in a locking ring 14 by way of comprising bifurcate ends, both parts of which include an aperture for alignment with the required aperture 15 in the locking ring 14; in this way these aligned apertures can receive a downwardly inserted wedge shaped pin 24 to secure the brace member 22 or 23 to the locking ring 14.

[0056] Alternatively, the additional formwork support members 21 can be free standing and supported only by way of the fork 12 at its upper end engaging with the formwork pan 19 that extends from the adjacent scaffold structure 10.

[0057] The resultant assembly of scaffolding structures 10 assembly has a number of evenly spaced forks 12 which enable placement of formwork pans 19 onto the structure to provide a continuous formwork surface on which to pour concrete.

[0058] As seen in Figures 11, 12 and 17, the scaffold structures 10 can be stacked (in pairs in this case) one on top of the other. Dowel joiners (illustrated with dashed lines in Figure 17) are used to secure the upper scaffold structure 10 to the lower one. The joiner 25 is located into the upper end of the vertical member 11 is bolted in place and the upper vertical member 11 is located over the extending joiner 25 and again bolted into place. As such, the upper scaffold structure 10 can be quickly and easily positioned on top of the lower scaffold structure 10.

[0059] Likewise, the additional formwork support members 21 can be assembled in a similar manner using the joiners 25.

[0060] Referring now to Figures 14 and 15, where there is illustrated the assembly of scaffolding structures 10 of Figures 11 and 12, with deck elements 26 extending horizontally through the rigid scaffolding structure 10. The deck elements 26 comprise a panel with a u-shaped connector at each of the panels with the u-shaped connector sitting on top of the connecting members 13. This provides a continuous walkway through adjacent scaffold structures 10. In this arrangement, the deck elements 26 are positioned between adjacent formwork support members comprising single scaffold structure 10, and additional deck elements 26 extend between adjacent scaffold structures 10. This provides an elevated working surface which gives required access to the upper portions of the lower scaffold structures 10 in order to place the upper scaffold structures 10 in place and provide access to the forks 12 and the fork extension elements. Finally, it provides a safe working surface in order to locate the formwork pans 19 within the respective forks 12.

[0061] A brace member 22 extends between adjacent scaffold structures 10 with wedge pins located through each end of the brace member 22 and a u-shaped metal strip 27. The wedge pin locks the joint between the brace member 22 and the u-shaped metal strip 27 to form a solid joint and the wedge pin may be provided with a safety locking pin at its lower end to prevent accidental release of the wedge pin.

[0062] Throughout the specification and the claims that follow, unless the context requires otherwise, the words "comprise" and "include" and variations such as "comprising" and "including" will be understood to imply the inclusion of a stated integer or group of integers, but not the exclusion of any other integer or group of integers.

[0063] The reference to any prior art in this specification is not, and should not be taken as, an acknowledgement of any form of suggestion that such prior art forms part of the common general knowledge.

[0064] It will be appreciated by those skilled in the art that the invention is not restricted in its use to the particular application described. Neither is the present invention restricted in its preferred embodiment with regard to the particular elements and/or features described or depicted herein. It will be appreciated that the invention is not limited to the embodiment or embodiments disclosed, but is capable of numerous rearrangements, modifications and substitutions without departing from the scope of the invention as set forth and defined by the following claims.

CLAIMS

1. A formwork support member comprising at least two spaced vertical members, at least one connecting member bridging said vertical members to form a rigid formwork support member, each vertical member including a plurality of attachment means at spaced intervals there-along for releasable attachment thereto of at least one brace member extending between adjacent formwork support members to form a rigid structure.
2. The formwork support member of claim 1, wherein each attachment means is adapted for releasable attachment thereto of a plurality of connecting members and/or brace members.
3. The formwork support member as in either of the preceding claims, wherein each of the attachment means comprises a plurality of spaced apart apertures.
4. The formwork support member of claim 3, wherein each of the attachment means comprises a ring around its respective vertical support member, where the apertures are spaced apart around the ring.
5. The formwork support member as in any one of the preceding claims, further comprising a forked element atop of each vertical member.
6. The formwork support member of claim 5, wherein the vertical support member comprises jacking means for raising and lowering the forked element.
7. The formwork support member as in any one of claims 1 through 4, wherein an upper end of each vertical member is adapted to support a second formwork support member atop of it, where each vertical member is attached to an adjacent lower vertical member of the lower formwork support member.
8. A scaffold structure comprising at least a pair of adjacent formwork support members, each formwork support member comprising at least two spaced vertical members, at least one connecting member bridging said vertical members, each vertical member including a plurality of attachment means at spaced intervals there-along, the scaffold structure further comprising at least one brace member extending between and releasably attached at each end thereof to the adjacent formwork support members.
9. The scaffold structure of claim 8, comprising a plurality of brace members extending between and releasably attached at each end thereof to attachment means of the adjacent formwork support members.

10. The scaffold structure as in either of claims 8 or 9, wherein the pair of formwork support members are secured to one another by a pair of diagonal brace members, each of which extend from a lower attachment position on one formwork support member to an upper attachment position on the adjacent formwork support member.
11. The scaffold structure of claim 10, wherein the pair of formwork support members are secured to one another by four diagonal braces comprised of two pairs of diagonal brace members, one pair each extending between two spaced vertical members.
12. The scaffold structure as in any one of the preceding claims, further comprising at least one horizontal brace member extending between and releasably attached at each end thereof to attachment means of the adjacent formwork support members.
13. The scaffold structure of claim 12, further comprising at least one deck element bridging any one of a pair of connecting members, a pair of horizontal brace members, or a connecting member and a horizontal brace member.
14. The scaffold structure as in any one of claims 8 through 13, wherein each attachment means is adapted for releasable attachment thereto of a plurality of connecting members and/or brace members.
15. The scaffold structure as in any one of claims 8 through 14, wherein each of the attachment means comprises a plurality of spaced apart apertures.
16. The scaffold structure of claim 15, wherein each of the attachment means comprises a ring around its respective vertical support member, where the apertures are spaced apart around the ring.
17. The scaffold structure as in any one of claims 8 through 16, further comprising a forked element atop of each vertical member.
18. The formwork support member of claim 14, wherein the vertical support member comprises jacking means for raising and lowering the forked element.
19. The formwork support member as in any one of claims 8 through 16, wherein an upper end of each vertical member may be used to support a second formwork support member atop of it, where each vertical member is attached to an adjacent lower vertical member of the lower formwork support member.

20. An assembly of scaffold structures comprising at least a pair of the scaffold structures of any one of claims 9 through 19, and at least one brace member extending between and releasably attached at each end thereof to the adjacent formwork support members.

21. An assembly of scaffold structures comprising a scaffold structure as in any one of claims 9 through 19 stacked atop of a scaffold structure of claim 7.

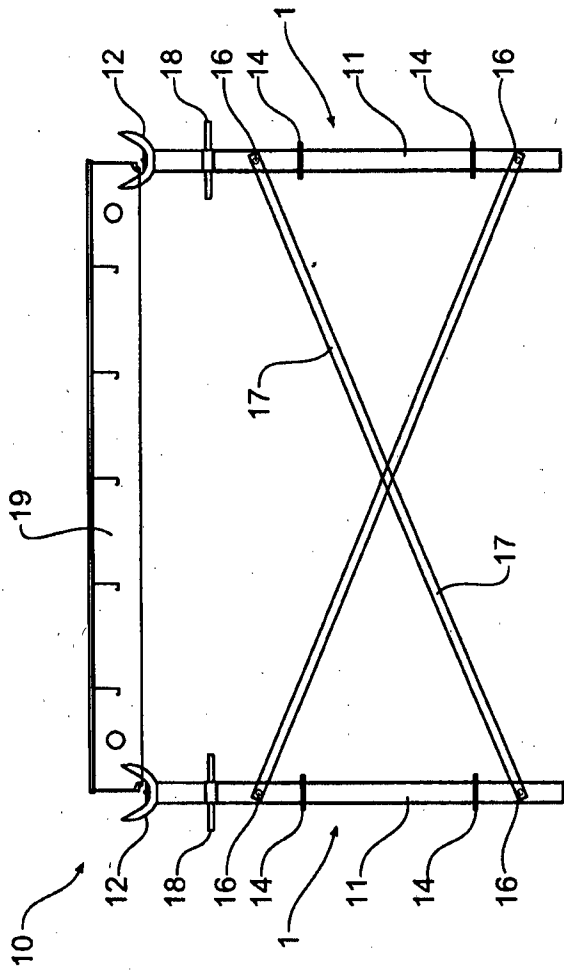

Figure 1

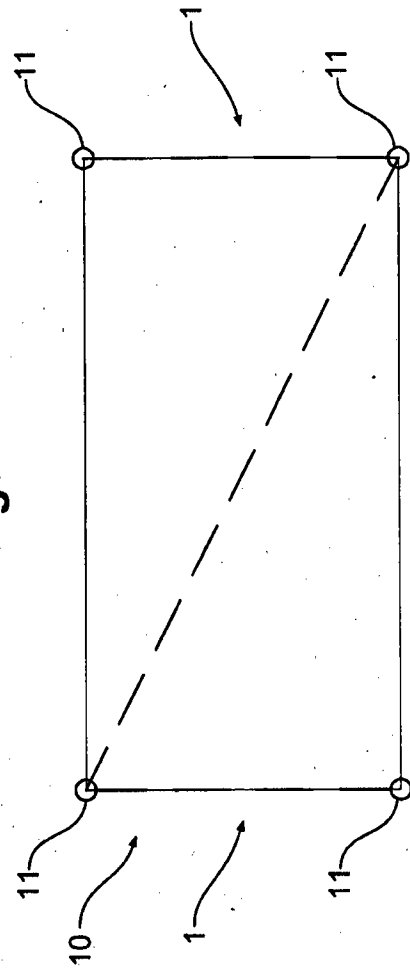

Figure 2

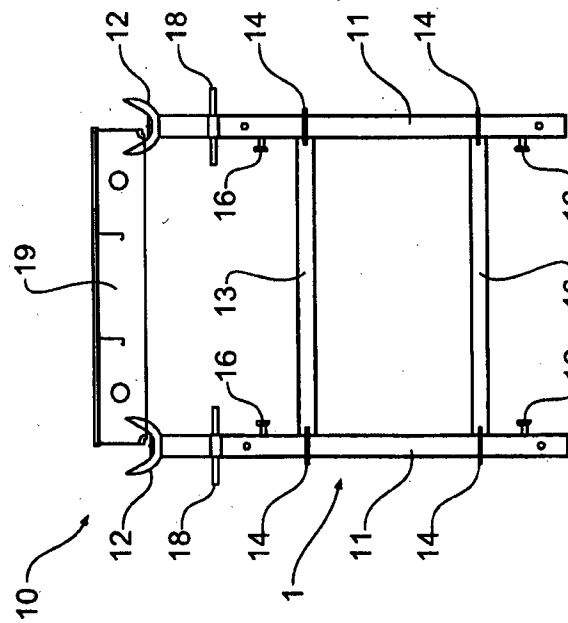

Figure 3

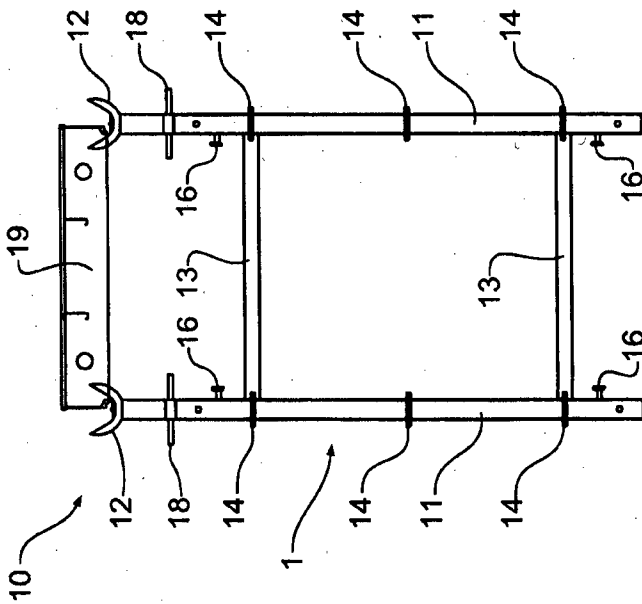
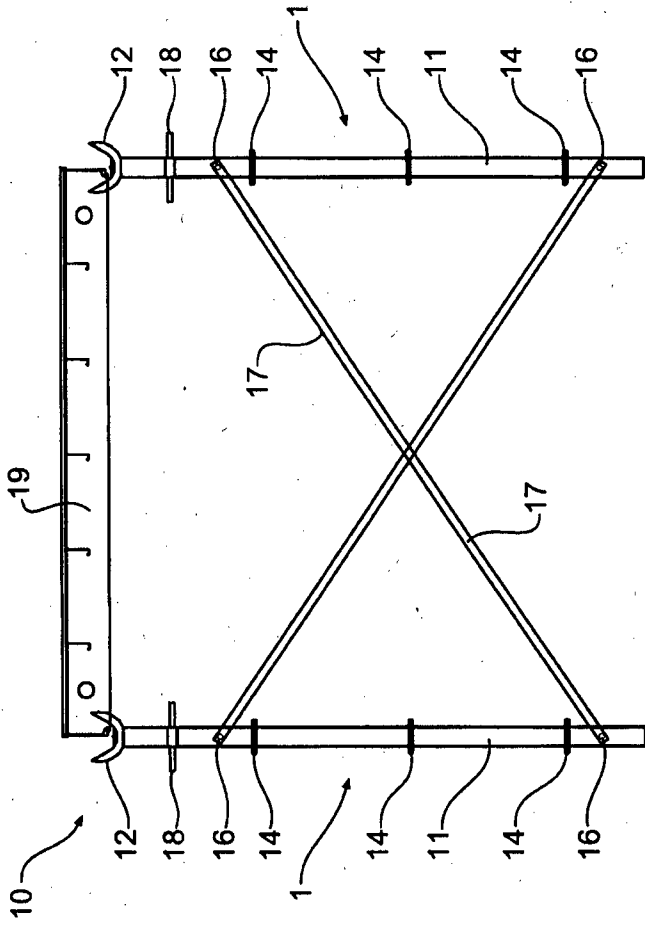

Figure 4

Figure 5

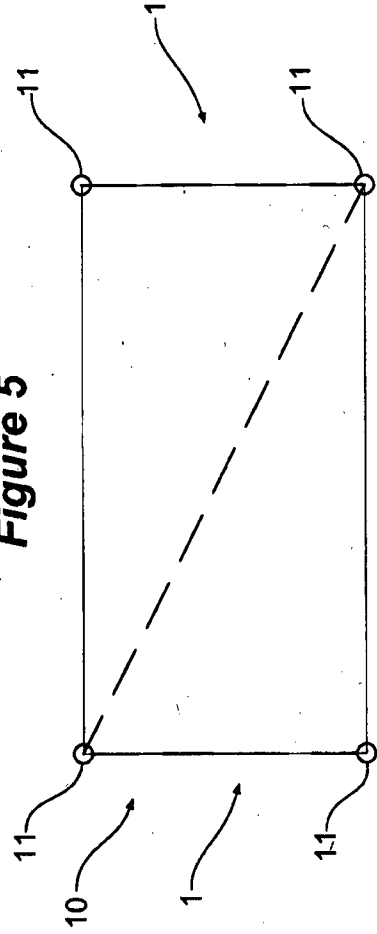

Figure 6

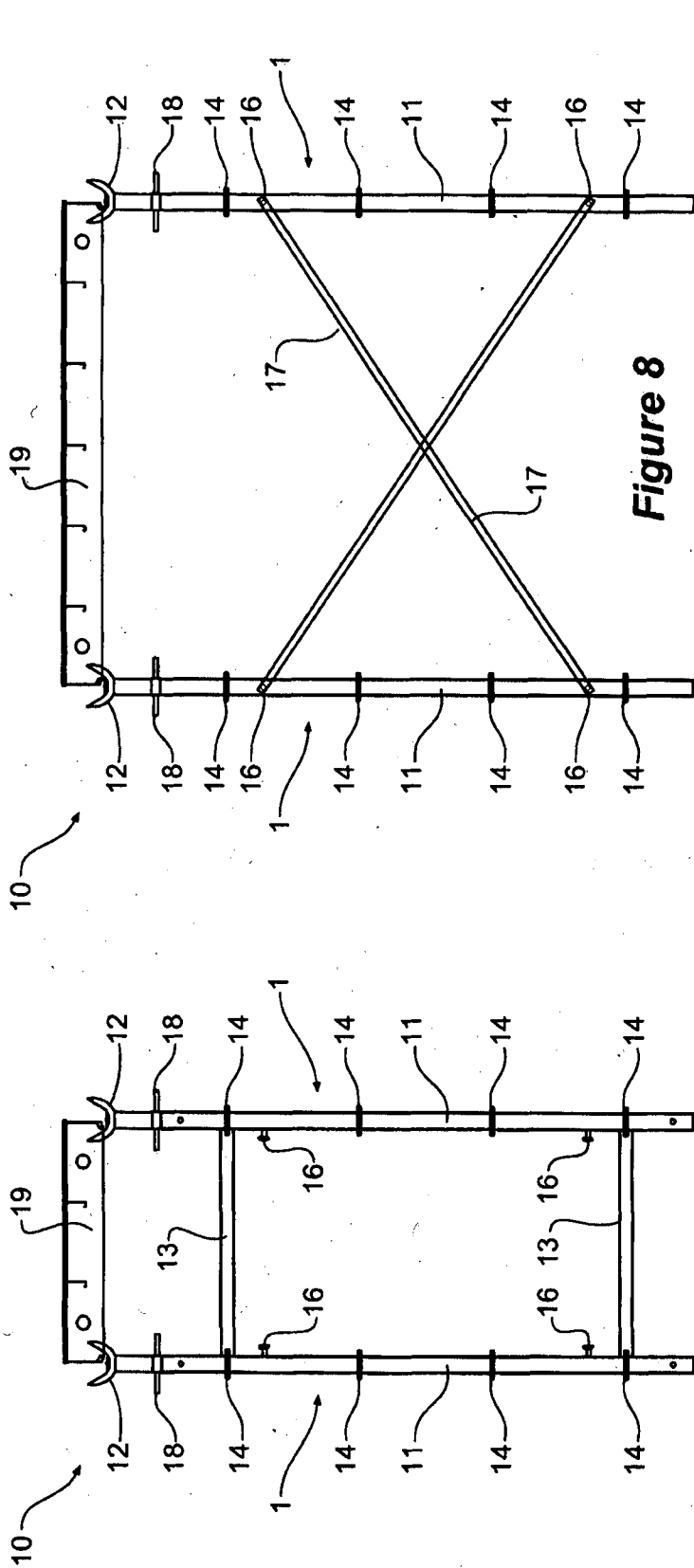

Figure 8

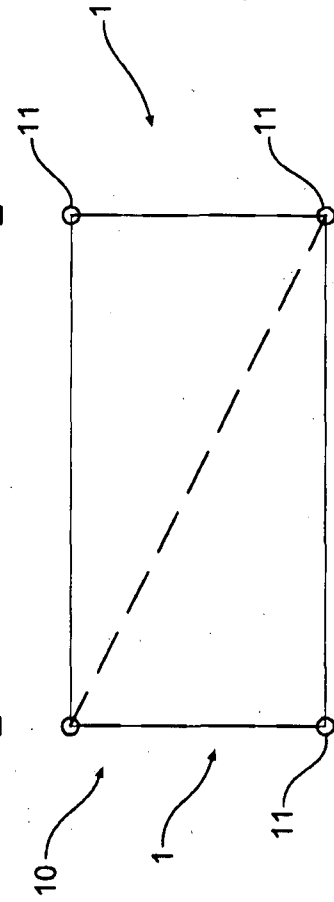

Figure 9

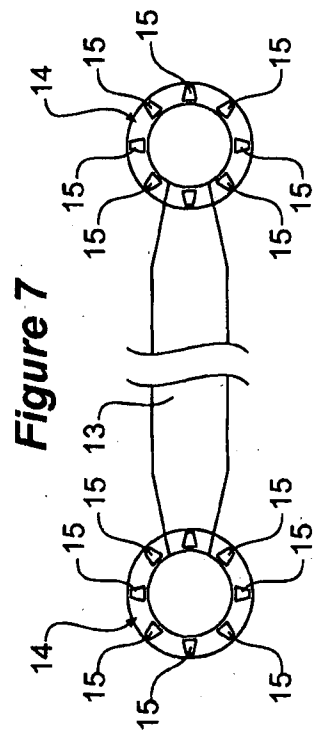

Figure 7

Figure 10

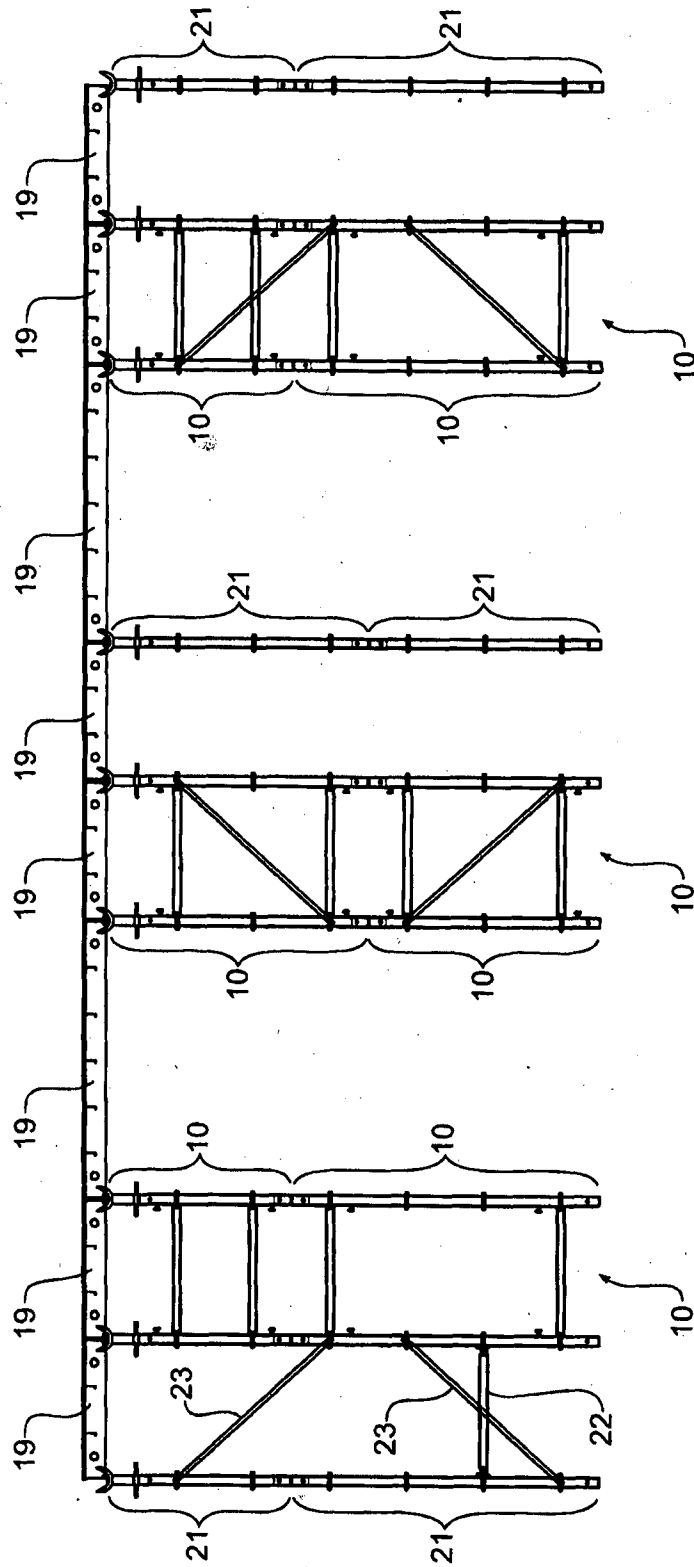

Figure 11

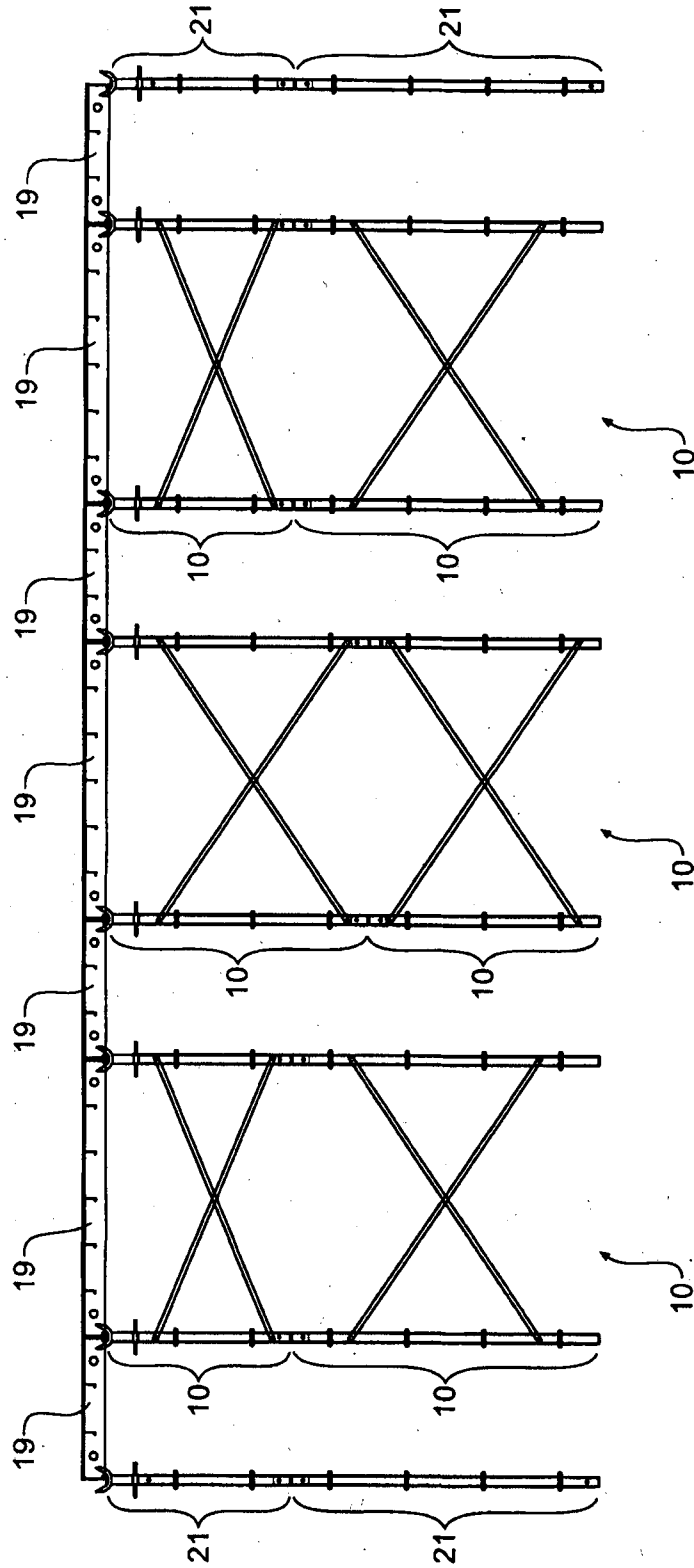

Figure 12

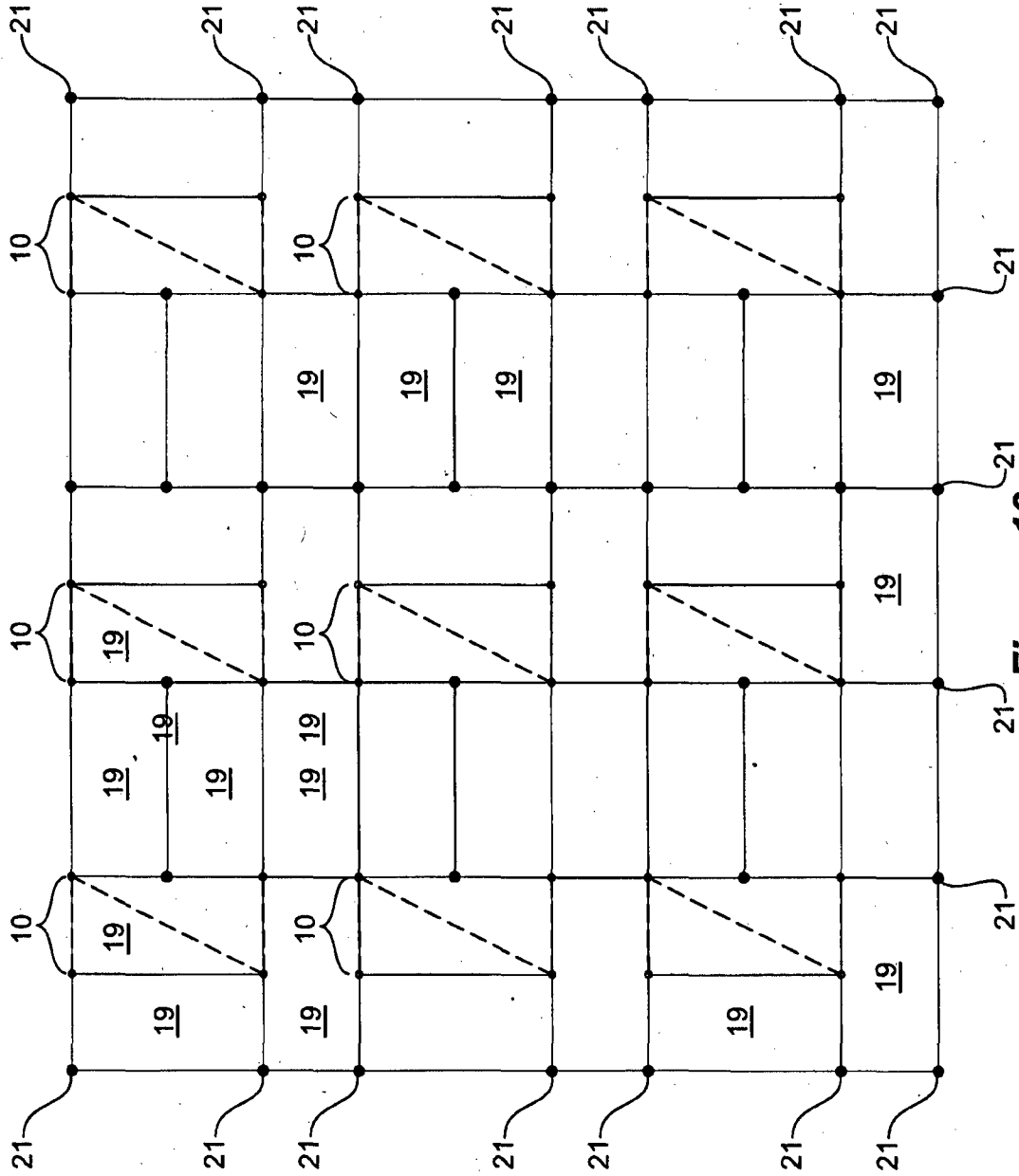

Figure 13

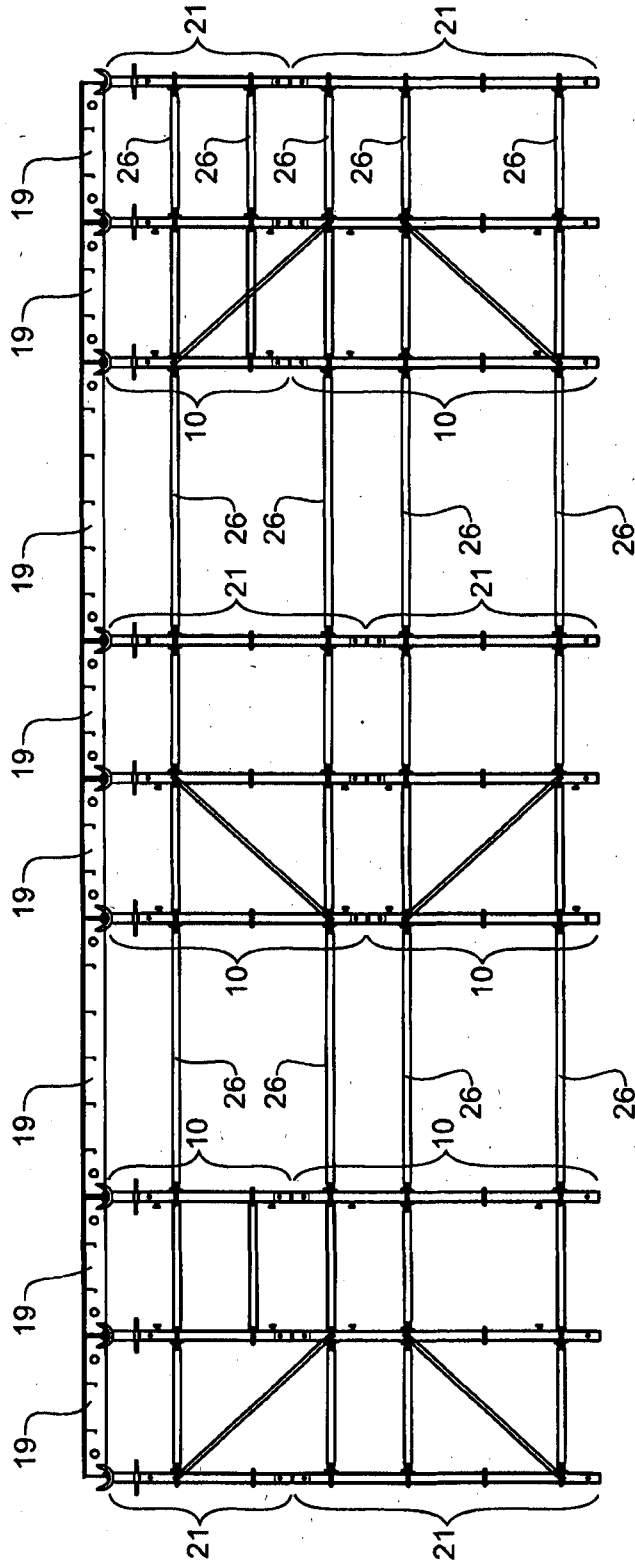

Figure 14

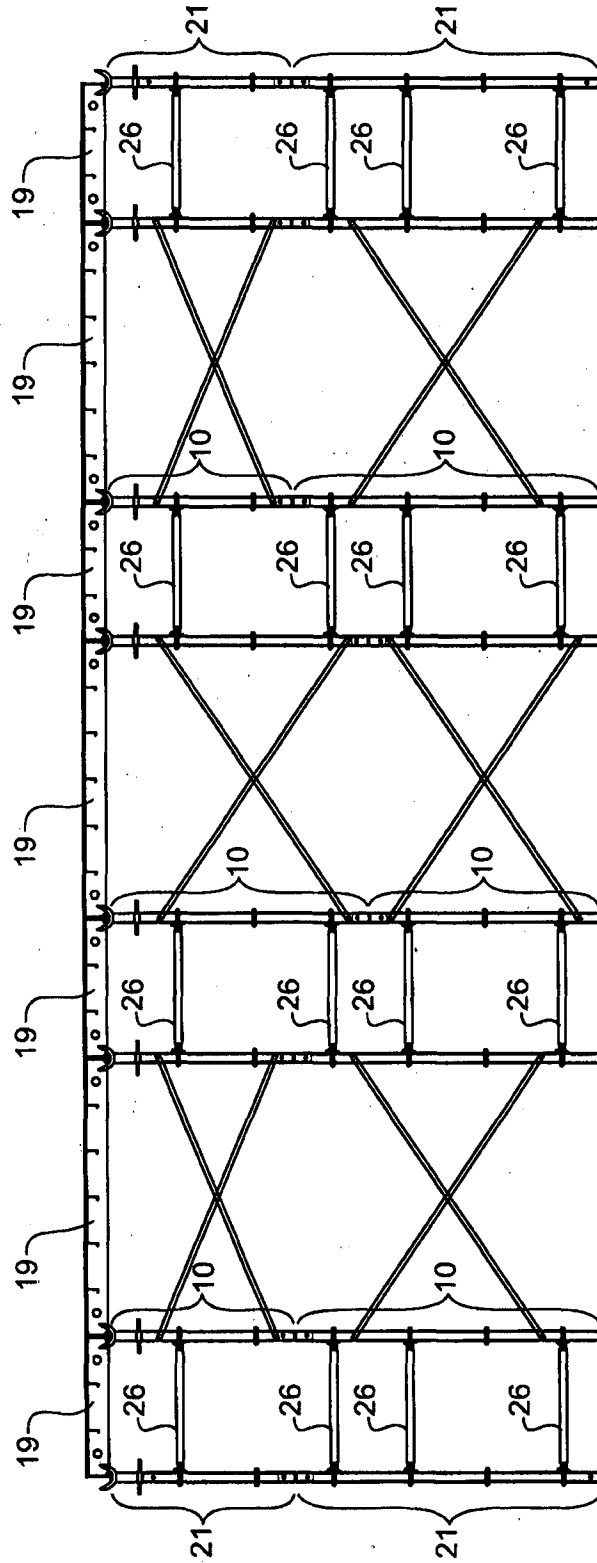

Figure 15

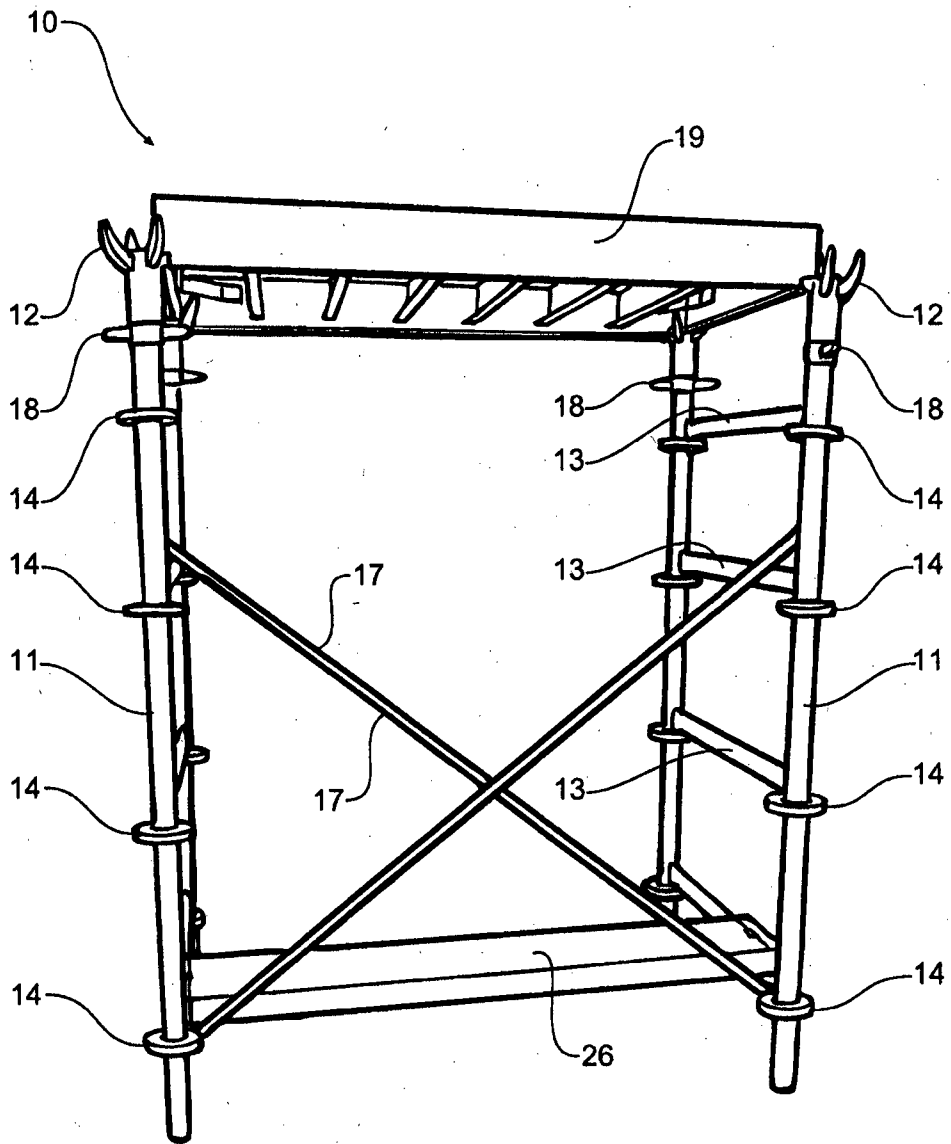

Figure 16

10/11

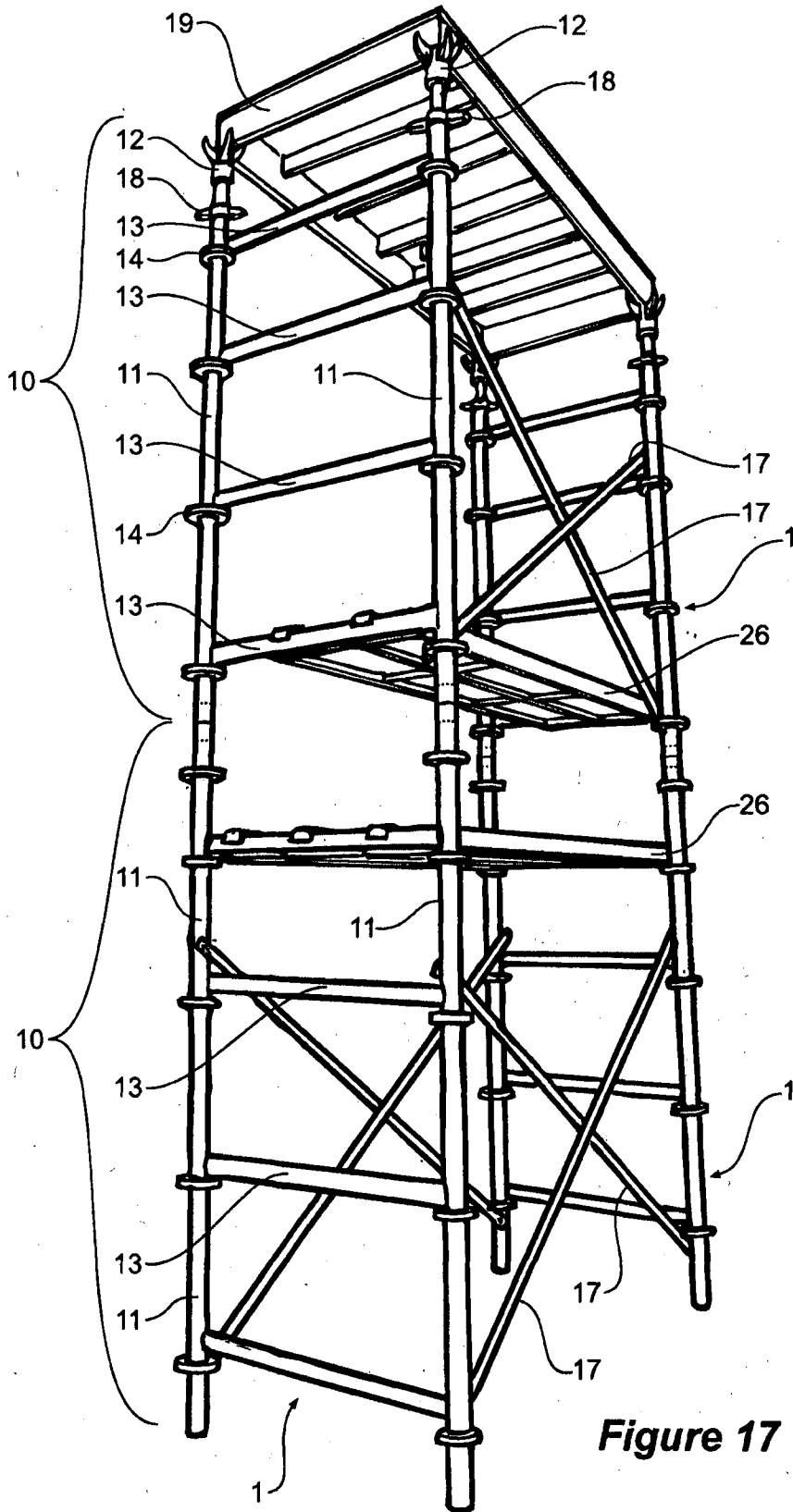

Figure 17

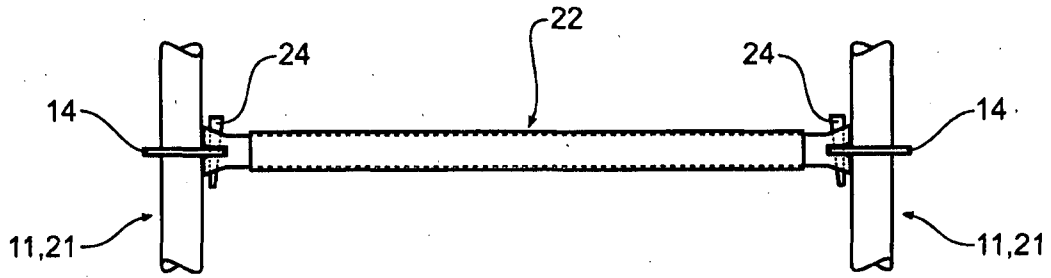

Figure 18

INTERNATIONAL SEARCH REPORT

International application No.

PCT/AU2013/000855

A. CLASSIFICATION OF SUBJECT MATTER

E04G 11/48 (2006.01) E04G 1/14 (2006.01)

According to International Patent Classification (IPC) or to both national classification and IPC

B. FIELDS SEARCHED

Minimum documentation searched (classification system followed by classification symbols)

Documentation searched other than minimum documentation to the extent that such documents are included in the fields searched

Electronic data base consulted during the international search (name of data base and, where practicable, search terms used)

EPODOC & WPI: IPC & CPC E04G1/14, /15/LOW, 11/48 & /483: with KW (FORMWORK, SHORING, CAST, FALSEWORK, BRACE DIAGONAL, RING, FLANGE DISK PLATE, HOLE SLOT APERTURE) and like terms.

C. DOCUMENTS CONSIDERED TO BE RELEVANT

Category*	Citation of document, with indication, where appropriate, of the relevant passages	Relevant to claim No.
	Documents are listed in the continuation of Box C	



Further documents are listed in the continuation of Box C



See patent family annex

* Special categories of cited documents:		
"A" document defining the general state of the art which is not considered to be of particular relevance	"T" later document published after the international filing date or priority date and not in conflict with the application but cited to understand the principle or theory underlying the invention	
"E" earlier application or patent but published on or after the international filing date	"X" document of particular relevance; the claimed invention cannot be considered novel or cannot be considered to involve an inventive step when the document is taken alone	
"L" document which may throw doubts on priority claim(s) or which is cited to establish the publication date of another citation or other special reason (as specified)	"Y" document of particular relevance; the claimed invention cannot be considered to involve an inventive step when the document is combined with one or more other such documents, such combination being obvious to a person skilled in the art	
"O" document referring to an oral disclosure, use, exhibition or other means	"&" document member of the same patent family	
"P" document published prior to the international filing date but later than the priority date claimed		

Date of the actual completion of the international search
15 October 2013Date of mailing of the international search report
15 October 2013

Name and mailing address of the ISA/AU

AUSTRALIAN PATENT OFFICE
PO BOX 200, WODEN ACT 2606, AUSTRALIA
Email address: pct@ipaustralia.gov.au
Facsimile No.: +61 2 6283 7999

Authorised officer

Stefan Ochsenbein
AUSTRALIAN PATENT OFFICE
(ISO 9001 Quality Certified Service)
Telephone No. 0262832269

INTERNATIONAL SEARCH REPORT

International application No.

C (Continuation).

DOCUMENTS CONSIDERED TO BE RELEVANT

PCT/AU2013/000855

Category*	Citation of document, with indication, where appropriate, of the relevant passages	Relevant to claim No.
X	EP 1016766 A1 (ONO) 05 July 2000 Par[0001] and Fig43,44,54-61&69	1-4
X	DE 108008006911 A1 (WILHELM LAYHER VERWALTUNGS GMBH) 30 July 2009 Fig2-3&9-12	1-4
X	EP 0048624 A2 (ALUMINA SYSTEMS INCORPORATED) 31 March 0982 Fig1	1

Box No. II Observations where certain claims were found unsearchable (Continuation of item 2 of first sheet)

This international search report has not been established in respect of certain claims under Article 17(2)(a) for the following reasons:

1. Claims Nos.:
because they relate to subject matter not required to be searched by this Authority, namely:

2. Claims Nos.:
because they relate to parts of the international application that do not comply with the prescribed requirements to such an extent that no meaningful international search can be carried out, specifically:

3. Claims Nos.:
because they are dependent claims and are not drafted in accordance with the second and third sentences of Rule 6.4(a)

Box No. III Observations where unity of invention is lacking (Continuation of item 3 of first sheet)

This International Searching Authority found multiple inventions in this international application, as follows:

See Supplemental Box for Details

1. As all required additional search fees were timely paid by the applicant, this international search report covers all searchable claims.
2. As all searchable claims could be searched without effort justifying additional fees, this Authority did not invite payment of additional fees.
3. As only some of the required additional search fees were timely paid by the applicant, this international search report covers only those claims for which fees were paid, specifically claims Nos.:

4. No required additional search fees were timely paid by the applicant. Consequently, this international search report is restricted to the invention first mentioned in the claims; it is covered by claims Nos.:
1-4

Remark on Protest

- The additional search fees were accompanied by the applicant's protest and, where applicable, the payment of a protest fee.
- The additional search fees were accompanied by the applicant's protest but the applicable protest fee was not paid within the time limit specified in the invitation.
- No protest accompanied the payment of additional search fees.

Supplemental Box

Continuation of: Box III

This International Application does not comply with the requirements of unity of invention because it does not relate to one invention or to a group of inventions so linked as to form a single general inventive concept.

This Authority has found that there are different inventions based on the following features that separate the claims into distinct groups:

- GROUP 1: Claims 1 to 7 are directed to a formwork support member comprising at least two spaced vertical members, at least one connecting member bridging said vertical members to form a rigid formwork support member, each vertical member including a plurality of attachment means at spaced intervals there along for releasable attachment thereto of at least one brace member extending between adjacent formwork support members to form a rigid structure. The feature of, a rigid formwork support member is specific to this group of claims. It is considered that the claims of GROUP 1 is directed toward the features of a specific component of a scaffold.
-
- GROUP 2: Claims 8 to 21 are directed to a scaffold structure comprising at least a pair of adjacent formwork support members, each formwork support member comprising at least two spaced vertical members, at least one connecting member bridging said vertical members, each vertical member including a plurality of attachment means at spaced intervals there along, the scaffold structure further comprising at least one brace member extending between and releasably attached at each end thereof to the adjacent formwork support members. The feature of a scaffold structure comprising one connecting member (that does not form a rigid formwork support member) and a brace member extending between and releasably attached at each end thereof to the adjacent formwork support is specific to this group of claims. It is considered that the claims of GROUP 2 is directed toward different arrangements of scaffold structures.

PCT Rule 13.2, first sentence, states that unity of invention is only fulfilled when there is a technical relationship among the claimed inventions involving one or more of the same or corresponding special technical features. PCT Rule 13.2, second sentence, defines a special technical feature as a feature which makes a contribution over the prior art.

When there is no special technical feature common to all the claimed inventions there is no unity of invention.

In the above groups of claims, the identified features may have the potential to make a contribution over the prior art but are not common to all the claimed inventions and therefore cannot provide the required technical relationship. The only feature common to all of the claimed inventions and which provides a technical relationship among them is to a **formwork support member** comprising at least **two spaced vertical members**, at least **one connecting member** bridging said vertical, each vertical member including a **plurality of attachment means** at **spaced intervals** there along.

However this feature does not make a contribution over the prior art because it is disclosed in:

EP0048624 A2 (ALUMA SYSTEMS INCORPORATED) 31 March 1982

Therefore in the light of this document this common feature cannot be a special technical feature. Therefore there is no special technical feature common to all the claimed inventions and the requirements for unity of invention are consequently not satisfied *a posteriori*.

Within **GROUP 1**, claims 1-7 this Authority has found that there are different inventions based on the following features that separate the claims into distinct groups:

Claim 1 does not make a contribution over the prior art because all the features are disclosed in:

EP0048624 A2 (ALUMA SYSTEMS INCORPORATED) 31 March 1982

INVENTION I: Claims 2-4 are directed to the formwork member of claim 1 comprising a **plurality of spaced apart apertures**. The feature of a **plurality of spaced apart apertures** is specific to this group of claims.

INVENTION III: Claims 5-6 are directed to the formwork member of claim 1 comprising a **forked element atop of each vertical member**. The feature of a **forked element atop of each vertical member** is specific to this group of claims.

Supplemental Box

INVENTION IV: Claim 7 is directed to the formwork member of claim 1 comprising an arrangement where **each vertical member is attached to an adjacent lower vertical member** of the lower formwork support member. The feature of **each vertical member is attached to an adjacent lower vertical member** is specific to this group of claims.

PCT Rule 13.2, first sentence, states that unity of invention is only fulfilled when there is a technical relationship among the claimed inventions involving one or more of the same or corresponding special technical features. PCT Rule 13.2, second sentence, defines a special technical feature as a feature which makes a contribution over the prior art.

When there is no special technical feature common to all the claimed inventions there is no unity of invention.

In the above groups of claims, the identified features may have the potential to make a contribution over the prior art but are not common to all the claimed inventions and therefore cannot provide the required technical relationship. Therefore there is no special technical feature common to all the claimed inventions and the requirements for unity of invention are consequently not satisfied *a priori*.

Within **GROUP 2**, claims 8-21 this Authority has found that there are different inventions based on the following features that separate the claims into distinct groups:

Claim 8 does not make a contribution over the prior art because all the features are disclosed in:

EP0048624 A2 (ALUMA SYSTEMS INCORPORATED) 31 March 1982

INVENTION II: Claims 9-11, 14 & 20 are directed to the scaffold structure of claim 8 comprising a **diagonal brace member**. The feature of a **diagonal brace members** is specific to this group of claims.

INVENTION V: Claim 12-13 are directed to the scaffold structure of claim 8 comprising a **horizontal brace member**. The feature of a **horizontal brace member** is specific to this group of claims.

PCT Rule 13.2, first sentence, states that unity of invention is only fulfilled when there is a technical relationship among the claimed inventions involving one or more of the same or corresponding special technical features. PCT Rule 13.2, second sentence, defines a special technical feature as a feature which makes a contribution over the prior art.

When there is no special technical feature common to all the claimed inventions there is no unity of invention.

In the above groups of claims, the identified features may have the potential to make a contribution over the prior art but are not common to all the claimed inventions and therefore cannot provide the required technical relationship. Therefore there is no special technical feature common to all the claimed inventions and the requirements for unity of invention are consequently not satisfied *a priori*.

Regarding claims 15-21: Where appended claims introduce features of one of the claimed inventions and yet are additionally appended to claims directed to any other of the claimed inventions, such claims will only be searched and reported on to the extent that additional search fees have been paid for all such claimed inventions.

Claims 15-16 are directed to a **plurality of spaced apart apertures** (INVENTION I).

Claims 17 -18 are directed to a **forked element atop of each vertical member** (INVENTION III).

Claims 19 & 21 are directed to an arrangement where **each vertical member is attached to an adjacent lower vertical member** of the lower support member (INVENTION IV).

It is considered that search and examination for **INVENTIONS II, III, IV & V** will require more than negligible additional search and examination effort over that for the **INVENTION I** and therefore three additional search fees are warranted.

INTERNATIONAL SEARCH REPORT

Information on patent family members

International application No.

PCT/AU2013/000855

This Annex lists known patent family members relating to the patent documents cited in the above-mentioned international search report. The Australian Patent Office is in no way liable for these particulars which are merely given for the purpose of information.

Patent Document/s Cited in Search Report		Patent Family Member/s	
Publication Number	Publication Date	Publication Number	Publication Date
EP 1016766 A1	05 Jul 2000	None	
DE 108008006911 A1	30 Jul 2009	None	
EP 0048624 A2	31 Mar 0982	JP S57104763 A	29 Jun 1982
		JP H0258426 B2	07 Dec 1990

End of Annex