



28847/99



PCT

WORLD INTELLECTUAL PROPERTY ORGANIZATION  
International Bureau

INTERNATIONAL APPLICATION PUBLISHED UNDER THE PATENT COOPERATION TREATY (PCT)

<p>(51) International Patent Classification <sup>6</sup> : <b>B29B 17/00, 9/00, 9/02, B02C 18/44</b></p>	<p>A1</p>	<p>(11) International Publication Number: <b>WO 99/43480</b> (43) International Publication Date: 2 September 1999 (02.09.99)</p>
<p>(21) International Application Number: PCT/US99/04436 (22) International Filing Date: 26 February 1999 (26.02.99) (30) Priority Data: 60/076,209 27 February 1998 (27.02.98) US (71) Applicant: MAGUIRE PRODUCTS, INC. [US/US]; 11 Crozer- erville Road, Aston, PA 19014 (US). (72) Inventor: MAGUIRE, Stephen, B.; 1549 East Street Road, Glen Mills, PA 19432 (US). (74) Agent: QUINN, Charles, N.; Dann Dorfman Herrell and Skillman, P.C., Suite 720, 1601 Market Street, Philadelphia, PA 19103-2307 (US).</p>	<p>(81) Designated States: AL, AM, AT, AU, AZ, BA, BB, BG, BR, BY, CA, CH, CN, CU, CZ, DE, DK, EE, ES, FI, GB, GE, GH, GM, HR, HU, ID, IL, IS, JP, KE, KG, KP, KR, KZ, LC, LK, LR, LS, LT, LU, LV, MD, MG, MK, MN, MW, MX, NO, NZ, PL, PT, RO, RU, SD, SE, SG, SI, SK, SL, TJ, TM, TR, TT, UA, UG, UZ, VN, YU, ZW, ARIPO patent (GH, GM, KE, LS, MW, SD, SL, SZ, UG, ZW), Eurasian patent (AM, AZ, BY, KG, KZ, MD, RU, TJ, TM), European patent (AT, BE, CH, CY, DE, DK, ES, FI, FR, GB, GR, IE, IT, LU, MC, NL, PT, SE), OAPI patent (BF, BJ, CF, CG, CI, CM, GA, GN, GW, ML, MR, NE, SN, TD, TG).</p> <p><b>Published</b> <i>With international search report.</i> <i>Before the expiration of the time limit for amending the claims and to be republished in the event of the receipt of amendments.</i></p> <div data-bbox="976 869 1257 1025" style="border: 1px solid black; padding: 5px; text-align: center;"> <p>IP AUSTRALIA <b>15 SEP 1999</b> RECEIVED</p> </div>	
<p>(54) Title: RADIAL GRANULATOR AND METHOD</p>		
<p>(57) Abstract</p> <p>A method and apparatus for granulating previously molded solid thermoplastic material for recycling by introducing the previously molded thermoplastic material into a cylindrical granulating zone in a direction parallel with the axis of the cylinder, providing a stationary knife at a cylindrical boundary of the granulating zone, moving a second knife along the cylindrical boundary of the granulating zone to pass in proximity to the stationary knife and thereby trap portions of the previously molded thermoplastic material therebetween to cut the previously molded thermoplastic material into granules, providing an apertured surface as a portion of the cylindrical boundary and sweeping portions of the previously molded thermoplastic material along the apertured surface with the moving knife to cause cut portions of the previously molded thermoplastic material having granule size less than that of the apertures to pass therethrough for recycling by subsequent molding or other processing.</p>		

**RADIAL GRANULATOR AND METHOD****Field of the Invention**

This invention relates to reprocessing for recycling of solid thermo-plastic waste materials resulting from unsuccessful plastic molding operation and to the processing for recycling of solid plastic mold runners and sprues produced in the ordinary course of plastic injection or compression molding.

**Background of the Invention**

The plastics molding industry uses granulators to recycle discarded scrap materials which are produced incident to the production of injection molded or compression molded plastic products and for recycling defective molded products, where molding has been unsuccessful due to incomplete fill of the mold or unsatisfactory conditions within the mold.

Many plastic resin materials used in compression and injection molding may be repeatedly melted and formed. Thus, if a molded part is formed incorrectly or the desired shade of color is not obtained, the part can be ground into small granular particles and processed again.

In addition to scrap and malformed parts, parts are sometimes molded attached to a runner, which is a solid plastic tree connecting together two or more parts produced in separate cavities in the same mold. These runners may also be recycled; manufacturers utilize granulators to do this.

Sprues are solid plastic material resulting from cooling of molten plastic material in one or more passageways between the mold cavities in which the plastic parts are formed and the point of introduction of molten plastic material into the molding machine.

Granulators are normally selected based on the size(s) of the parts the granulator must ingest and the maximum throughput of such parts in pounds per hour. In a plastic molding facility there is often one granulator beside every molding press, with the granulator dedicated to grinding and returning to the process defective parts molded on that press as well as runners and sprues resulting in the molding process.

The requirements of such a small granulator are very low throughput, less than one hundred (100) pounds per hour under the most demanding circumstances, and to accept parts which have a maximum dimension of from six (6) to ten (10) inches in any direction.

Known granulators employ a reel-type blade assembly similar to that of a reel-type lawn mower. Such conventional granulators typically have two heavy side plates with bearings. Connecting these plates are heavy cross bars which hold bed knives, which are generally two (2) in number, positioned on opposite sides of the reel axis and oriented parallel to the axis of rotation of the reel. Journaled in the bearings retained by the side plates is a reel which is heavy and holds reel knives which are generally three (3) and sometimes five (5) in number. Plastic material to be granulated and recycled enters the cutting region perpendicular to the axis of reel rotation.

In such known granulators, distance between the side plates may be about twelve (12) inches and the cutting circle diameter may also typically be about twelve (12) inches. Hence the knives are about twelve (12) inches long. The possibility of making a single twelve (12) inch long cut, along the full length of a blade, in one hit on a single plastic part, determines the required power capacity for the motor, typically 5 or 10 horsepower even if gear reduction is used. Flywheels are often utilized to aid the motor in the cutting process.

A screen is fitted under the cutting chamber so only small particles escape the turning reel knives as the material churns within the cutting chamber. The cut material reduced to the small size passes out of the bottom through holes in the screen which are typically about one-quarter (1/4) inch diameter and can be from one-eighth (1/8) inch diameter up to about three-quarters (3/4) inch diameter, depending on the size of granules to be produced.

#### Summary of the Invention

A radial granulator apparatus is provided wherein the cutting chamber is oriented such that material enters in a

direction essentially parallel with the axis of rotor rotation. The granulator includes a cabinet, a motor, a rotor mounted on the motor shaft for rotation defining a cutting path, knives attached to the rotor, a filter ring circumscribing the rotor cutting path and having a plurality of stationary knives positioned therearound, an exit ring assembly behind the filter ring for channeling plastic materials of less than a specific size away from the cutting path and a storage bin for collecting granulated plastic material passing through the filter ring.

A feed hopper, at the top of the granulator, preferably has an offset opening that reduces "flyback" of particulate granular material resulting from granulating cutting taking place below. The lower portion of an internal hopper is configured to guide all material into a cylindrical cutting chamber. The cutting ring knives are stationary, being bolted to a flat base plate. A cutting ring with pockets receiving the knives fits over the knives, contacts the base plate and defines the cutting chamber.

The cylindrical cutting chamber permits use of a single bearing, a closely coupled direct drive motor and knives with very short cutting edges which are mounted on the rotor ends.

The rotor is preferably positioned facing somewhat upwardly, towards the path of material downward flow, while the filter is positioned around the circumference of the rotor cylindrical cutting path. A filter ring slips into place and is easily lifted out in a direction parallel to the rotor axis for cleaning. There may be three areas for material to exit, which are arcuate areas between the three stationary knives.

The filter is preferably a single steel ring, preferably notched to fit over the stationary cutting ring knives with arcuate trunco-cylindrical areas between the notches apertured for desired granular size. The apertured portion of the filter ring preferably traverses two-thirds (2/3) of the circumference of the rotor cylindrical cutting zone. The apertures can be extended to traverse a full 360°, namely the entire circumference of the cylindrical cutting path. However, since the cutting chamber is preferably slant positioned, the top

---

one third (1/3) contributes little to throughput of granules so aperatures may not be included in that portion.

In another of its aspects, this invention may be considered to provide a granulator including a housing having a scrap plastic material intake proximate an upper extremity thereof, with the upper extremity of the housing defining a downwardly leading chute for solid molded plastic material to be granulated and recycled. Preferably there is a baffle within the chute for at least partially laterally deflecting downwardly falling solid molded scrap plastic material to be granulated. A motor is connected to the housing and is preferably oriented with the shaft of the motor skew to the vertical.

The granulator further preferably includes a granulating assembly located within the housing and having a transversely elongated rotor connected to the shaft of the motor for rotation therewith. A first plurality of cutting knife blades are preferably connected to the rotor at transverse extremities thereof and are preferably oriented with cutting edges of the blades parallel with the motor shaft. A base plate preferably has the motor shaft rotatably journaled therewithin.

A second plurality of cutting knife blades define a circular array connected to the base plate and upstanding therefrom with cutting edges preferably oriented in a direction parallel both with the motor shaft and with the first plurality of cutting knife blade edges. An apertured ring includes notches therein for fitting around and over the second plurality of cutting knife blades.

Annular trunco-cylindrical back plates are supported by the base plate and are positioned radially outboard of the aperatured ring and axially substantially aligned with the apertured ring for deflecting granules of plastic material, resulting from cutting action of the first and second pluralities of cutting knife blades, passing through the aperatured ring downwardly for collection by a storage bin. The storage bin is preferably at the bottom of and within the housing.

In another of its aspects, this invention provides a method for granulating previously molded and/or waste solid

thermoplastic material for recycling through additional molding by introducing the previously molded and/or waste solid thermoplastic material into a cylindrical granulating zone via a cylinder end. The method further encompasses providing at least one stationary knife, preferably having length less than one-quarter (1/4) of the diameter the cylindrical granulating zone, at a cylindrical boundary of the granulating zone. The method yet further preferably encompasses moving at least one second knife, preferably having length substantially that of the stationary knife, along the cylindrical boundary of the granulating zone to pass in proximity to the stationary knife and thereby trap portions of the previously molded and waste solid thermoplastic material between the stationary moving knives and cut the portions into granules.

The method further preferably provides an apertured surface as a portion of the cylindrical boundary and further embraces sweeping portions of the previously molded and waste solid thermoplastic material along the apertured surface with a moving cutting knife thereby causing cut portions of the previously molded and waste thermoplastic material having granule size less than that of the apertures to pass therethrough for recycling via subsequent molding.

The invention yet further embraces a method for granulating previously molded and/or waste solid thermoplastic material for recycling through additional molding by introducing the previously molded and/or waste solid thermoplastic material into a cylindrical granulating zone in a direction parallel with the axis of the cylinder. This method aspect of the invention preferably provides at least one stationary knife at a cylindrical boundary of the granulating zone. This method aspect of the invention preferably moves a second knife along the cylindrical boundary of the granulating zone to pass in proximity to the stationary knife and thereby trap portions of the previously molded and waste solid thermoplastic material between the stationary and moving knives for cutting thereby into granules. The method provides an apertured surface as a portion of the cylindrical boundary. The method sweeps portions of the

previously molded and waste solid thermoplastic material along the apertured surface preferably with a moving knife thereby causing cut portions of the previously molded and waste thermoplastic material having granule size less than that of the apertures to pass therethrough for recycling via subsequent molding.

Desirably, the introducing step is performed by introducing the previously molded and/or waste solid thermoplastic material into a cylindrical granulating zone through the end of the cylinder.

Further desirably, in the method aspect of the invention the moving step preferably includes orienting the second knife with a knife cutting edge parallel with the axis of a cylinder defined by the granulating zone and moving the knife circumferentially around the cylindrical boundary of the granulating zone to pass in proximity to and thereby trap portions of previously molded and waste thermoplastic material between the stationary and moving knives for cutting thereby into granules.

In the method aspect of the invention, the introducing step yet further may encompass introducing the previously molded and/or waste solid thermoplastic material into the cylindrical granulating zone in a direction aligned with the axis of the cylinder.

In the method aspect of the invention, the axis of the cylinder may desirably be oriented skew to the vertical. Important features of the invention either singly or in combination are introductory feed of the solid molded thermoplastic material to be granulated and recycled in a direction parallel to and preferably aligned with the axis of the rotation of the motor and rotary cutter, as contrasted to perpendicular to the axis of the rotation of the motor and rotary cutter, inclusion of a higher number of stationary cutting knives than moving, rotating cutting knives, a filter screen for the granules extending circumferentially entirely around the granulating cutting chamber, a granulating knife cutting edge length which is a fraction of the diameter of the cutting circle

circumscribed by the cutting rotor, a single piece cutting chamber formed using a unitary ring and an internal removable feed hopper facilitating easy clean up and rapid change over to different granule size.

#### Brief Description of the Drawings

Figure 1 is a side schematic view of a radial granulator manifesting aspects of the invention showing the preferred orientation of the granulating motor assembly and material intake path.

Figure 2 is a diagrammatic perspective view of the granulating assembly of the radial granulator illustrated in Figure 1.

Figure 3 is a front schematic view of a radial granulator manifesting aspects of the invention as illustrated generally in Figures 1 and 2, with internal parts shown in dotted lines in schematic form.

#### Detailed Description of the Preferred Embodiments and Best Mode Known for Practicing the Invention

The radial granulating apparatus of this invention provides a cutting chamber is oriented such that material enters from a direction forward and parallel to the axis of granulating blade rotation. The granulator apparatus is designed for use with thermoformable materials such as plastics. The apparatus includes a cabinet, a motor, a rotor mounted on the motor shaft for rotation about a cutting path, knife attachments for the rotor, a filter ring circumscribing the rotor cutting path with a plurality of stationary knives positioned therearound, an exit ring assembly positioned behind the filter ring for channeling plastic materials less than a specific size away from the cutting path, and a storage bin for collecting granulated plastic material passed through the filter assembly.

Referring now to Figure 1 a radial granulator manifesting aspects of the invention is designated generally 5. The radial granulator includes a cabinet 7 for housing an electromechanical granulating assembly, which is designated generally 10. The cabinet is typically manufactured of

galvanized sheet metal. An upper portion of cabinet 7 is formed to channel materials along an intake path 12 downwardly to the granulating assembly 10 which is driven by a motor 20.

The top of the radial granulator cabinet 7, has an offset opening denoted by horizontal lines 42, 44 that aids in reducing "flyback" of granulated plastic material resulting from the cutting action below. The lower portion of an internal hopper 46 having an upper extremity defined by offset line 44 guides downwardly falling plastic material to be granulated for recycling into a cutting chamber directed by internal baffle 14 for orienting intake materials such that they enter the cutting chamber of granulating assembly 10 from a direction parallel to the axis of blade rotation as indicated by directional arrow A in Figure 1. The axis of rotation of the output shaft of motor 20 is designated 48 in Figure 1. Cabinet 7 additionally includes a front access panel 16 for accessing the portion of intake path 12 within and accessing storage bin 18 which collects granulated plastic material provided to it by granulating assembly 10.

The electromechanical granulating assembly 10 is typically powered by an alternating current source of 120-240 volts, depending on the requirements of motor 20 driving granulating assembly 10. In the preferred embodiment, the motor is of low horsepower, typically a three (3) horsepower motor.

Referring now to Figure 2, granulating assembly 10 includes rotor 22 mounted on an output shaft 50 of motor 20 granulating assembly 10 further includes a filter ring 32 which is of annular configuration and is preferably notched to fit over stationary knives 26a, 26b and 26c, which are preferably fixably connected to base plate 34. In the preferred embodiment of the invention, knives 24, 26 are about one and three-quarters (1 3/4) inches high where this dimension is measured in the axial direction parallel with the axis of rotation 50 of motor 20. Motor 20 is not illustrated in Figure 2.

A cutting chamber 52 is of cylindrical configuration and is defined by the annular inwardly facing surface of filter ring 32 which fits about stationary knives 26a, 26b and 26c. In the preferred practice of the invention, the cutting chamber 52

---

has a diameter of about ten (10) inches and may be as high as fifteen (15) inches.

Rotor 22 is preferably a two (2) inch square steel bar and is preferably about nine (9) inches long with knives 24a, 24b at either end positioned to essentially tangentially contact the annular inwardly facing surface of filter ring 32. Note that stationary knives 26a, 26b and 26c are disposed essentially radially with respect to the axis of rotation of motor output shaft 50, as illustrated in Figure 2, whereas knives 24a, 24b mounted at the transverse extremities of rotor 22 are canted with respect to rotor 22. This canted position effectively serves to trap solid plastic material to be recycled between cutting edges of moving knives 24a, 24b and stationary knives 26a, 26b and 26c as rotor 22 rotates thereby causing this material to be cut between the edges of the knives into small granules. The small granules then pass through apertures 28 in filtering 32 and pass downwardly between filtering 32 and exit ring 30 falling into a storage bin 18 positioned below the granulator assembly.

A bearing locates and connects rotor 22 to ring 32 through a base plate 34.

Motor 20 has a shaft 50 operably connected to rotor 22. The ends of rotor 22 moves along cutting path 40; ends of rotor 22 have knives 24a and 24b secured thereto for sweeping rotary movement along cutting path 40.

The cutting path 40 of knives 24a and 24b is circular, bounded by filter ring 32. Filter ring 32 is preferably a single steel band, preferably notched to fit over stationary knives 26a, 26b, 26c.

The portions of filter ring 32 between the stationary knife notches have a plurality of apertures of diameter consistent with the largest size granule desired to be passed by granulating assembly 10. The aperture portion of the filter ring preferably traverses two-thirds (2/3) around the rotor cutting path. In an alternative embodiment, apertures may traverse the full 360° of cutting path 40 however, the orientation of the granulating assembly 10 in the preferred embodiment has motor

shaft 50 sloped so that the top one-third (1/3) of the cutting path contributes little to throughput.

Stationary knives 26a, 26b, 26c are secured to base plate 34 and spaced symmetrically therearound for granulating cooperation with knives 24a, 24b carried by rotor 22.

Exit ring 30 is positioned behind filter ring 32 such that channels 36 are formed between the apertured portions of the filter ring 32 and exit ring 30. Channels 36 provide a path, which may pass through base plate 34, to storage bin 18 positioned underneath, for the passage of granules of having a maximum dimension corresponding to that of apertures of filter ring 32.

Plastic material flowing along intake path 12 is directed towards granulating assembly 10 in a direction parallel to the axis of rotation of rotor 22, which is defined by motor shaft 50, for granulation into granules of a size having a maximum dimension corresponding to that of the apertures of filter ring 32. The granules pass through the apertured portion of filter ring 32 down through exit channel 36 to storage bin 18.

In one preferred practice of the invention, moving in stationary knives 24, 26 are one and three-quarters ( $1 + 3/4$ ) inches long with length being measured in a direction parallel to the axis of rotation of rotor 22 on which moveable knives 24 are mounted. In this preferred practice of the invention, motor 20 is a three (3) horsepower and the cutting chamber defined by filter ring 32, exit ring 30 and base plate 34 has a ten (10) inch inside diameter measured at the annular inwardly facing surface of filter ring 32, a fifteen (15) inch outside diameter measured at the outer annular surface of base plate 34 at a height of one and three-quarters ( $1 + 3/4$ ) inches measured and parallel to the axis of rotation of motor 20. In this preferred practice of the invention, rotor 22 is a two (2) inch square steel bar of nine (9) inches in length with knives 24 located at either end of rotor 22. Knives 24 are preferably canted with respect to rotor 22 so as to form an angle of about eighty degrees ( $80^\circ$ ) at the point of tangency and close approach to filter ring 32. This is to be contrasted to stationary knives

26 which preferably form an angle of ninety degrees (90°) with the inner surface of filter ring 32.

The geometry of cutting chamber 62 defined by filter ring 32, base plate 34, rotor 22 and knives 24, 26 permits feed of the plastic material to be recycled in a direction essentially parallel to the axis of rotation of rotor 22. This geometry and the resultant mechanical advantage inherent in the geometrical design facilitates use of lower horsepower motors than known heretofore in the granulating art thereby providing for a lower cost granulator apparatus.

Stationary knives 26 are preferably bolted to base plate 34. Filter ring 32 having pockets formed therein for fitting over stationary knives 26 fits over top of stationary knives 26 and flushly abuts base plate 34. Filter ring 32 is retained in place by internal hopper 46 which bears downwardly against the upwardly facing surface of filter ring 32.

As illustrated in Figure 3 in schematic form, internal hopper 46 is suspended from frame members internal of cabinet 7 via hopper suspension plates 58 and, as noted above, essentially rests on the upper surface of filter ring 32 thereby retaining filter ring 32 in place as the granulating process proceeds. Internal hopper 46 includes internal baffle 14 and hopper side plates 60. The suspension of internal hopper 46 via hopper suspension plates 58 allows internal hopper 46 to be lifted out of cabinet 7 when it is desired to clean the apparatus or it is desired to change filter ring 32 to produce a different size of granular material for recycling.

As further illustrated in Figure 3, a pair guide plates are located above internal hopper 46 and serve to downwardly channel flow of solid molded plastic material to be recycled downwardly into the cutting chamber 62.

In the geometry of the cutting chamber, the ratio of knife edge length to cutting circle diameter is considerably less than one to one; it is this ratio which affects the power required to be supplied by motor 20 and thereby facilitates the mechanical advantage and resultant efficiency provided by the granulator embodying the invention.

---

Cabinet 7 further preferably includes a front door, which is interlocked with the power to motor 20, for safety purposes and opens for easy access to the interior of the cutting chamber. Internal hopper 46 may be removed via this door. Once the interior hopper 46 is removed, filter ring 32 may be replaced or cleaned as desired.

The inlet to internal hopper 46 is offset from an inlet for plastic material to be recycled into the granulator where this inlet is defined by an extremity of upper deflector plate 54 illustrated in Figure 3. Upper deflector plate 54 and its extremities serves to force incoming solid plastic material to be granulated laterally and serves to largely block flyback thereby preventing solid plastic material from flying out of the granulator material via the upper, preferably open feed aperture at the top of the granulator.

What is claimed is:

1. A granulator comprising:
  - a. a housing having a scrap plastic material intake proximate an upper extremity thereof;
  - b. the upper interior of said housing defining a downwardly leading chute for scrap plastic material to be granulated;
  - c. a baffle within said chute for at least partially laterally deflecting downwardly falling solid scrap plastic material to be granulated;
  - d. a motor connected to said housing and oriented with the shaft of said motor skew to the vertical;
  - e. a granulating assembly located within said housing and comprising:
    - i. a transversely elongated rotor connected to the shaft of said motor for rotation therewith;
    - ii. a first plurality of cutting knife blades connected to said rotor at transverse extremities thereof and oriented with cutting edges of said blades parallel with said motor shaft;
    - iii. a base plate having said motor shaft rotatably journaled therewithin;
    - iv. a second plurality of cutting knife blades defining a circular array, connected to said baseplate and upstanding therefrom with cutting edges oriented in a direction parallel with said motor shaft and said first plurality of cutting knife blade edges;
    - v. an apertured ring including notches therein for fitting around said second plurality of cutting knife blades;
    - vi. annular trunco-cylindrical backplates supported by said baseplate, positioned radially outboard of said apertured ring and axially substantially aligned therewith for deflecting granules of plastic material, resulting from cutting action

- of said first and second pluralities of cutting knife blades, passing through said apertured ring downwardly for collection by a storage bin;
- f. said storage bin being at the bottom of and within said housing.
2. A granulator comprising:
- a. a scrap plastic material intake;
  - b. a downwardly leading scrap material chute connected to said intake for channel scrap plastic material to be granulated into a granulating zone;
  - c. means connected to said chute for laterally deflecting solid scrap plastic material flowing through said chute;
  - d. a motor including an output shaft;
  - e. a granulating assembly comprising:
    - i. a transversely elongated rotor connected to the shaft of said motor for rotation therewith;
    - ii. at least one cutting knife blade connected to said rotor at a transverse extremity thereof and oriented parallel with said motor shaft;
    - iii. a base having said shaft rotatably journaled therewithin;
    - iv. at least one stationary second cutting knife blade positioned for circular tangency respecting a cylindrical swath defined by said cutting knife blade connected to said rotor upon rotation thereof, connected to said base and upstanding therefrom with a cutting edge oriented in a direction parallel with said motor shaft and said edge of said cutting knife blade mounted on said rotor;
    - v. an apertured ring fitting around said stationary cutting knife; and
    - vi. backplate means supported by said base, radially outboard of said apertured ring and axially aligned therewith for deflecting granules of plastic material produced by cutting action of

said first and second pluralities of cutting knife blades passing through said apertured ring, downwardly for gravity induced fall into granular material collection means.

3. The granulator of claim 1 wherein apertures in said ring circumscribe an angle of 240°.
4. The granulator of claim 1 wherein apertures in said ring circumscribe an angle of 360°.
5. The granulator of claim 1 wherein said second plurality of cutting knife blades is greater in number than said first plurality.
6. The granulator of claim 1 wherein said knife blades of said first and second pluralities are substantially the same length.
7. The granulator of claim 1 wherein said knife blades have axial length less than one-fourth (1/4) transverse length of said rotor.
8. The granulator of claim 3 wherein said apertured portion of said ring is symmetrical about a vertical axis and faces downwardly.
9. A method for granulating previously molded and/or waste solid thermoplastic material for recycling through additional molding, comprising:
  - a. introducing said previously molded and/or waste solid thermoplastic material into a cylindrical granulating zone in a direction parallel with the axis of said cylinder;
  - b. providing at least one stationary knife at a cylindrical boundary of said granulating zone;
  - c. moving a second knife along said cylindrical boundary of said granulating zone to pass in proximity to said stationary knife and thereby trap portions of said previously molded and waste solid thermoplastic material between said stationary and said moving knives for cutting thereby into granules;
  - d. providing an apertured surface as a portion of said cylindrical boundary;

- e. sweeping portions of said previously molded and waste solid thermoplastic material along said apertured surface with said moving knife thereby causing cut portions of said previously molded and waste solid thermoplastic material having granule size less than that of said apertures to pass therethrough for recycling via subsequent molding.
10. A method for granulating previously molded and/or waste solid thermoplastic material for recycling through additional molding, comprising:
- a. introducing said previously molded and/or waste solid thermoplastic material into a cylindrical granulating zone via a cylinder end;
  - b. providing at least one stationary knife at a cylindrical boundary of said granulating zone;
  - c. moving a second knife along said cylindrical boundary of said granulating zone to pass in proximity to said stationary knife and thereby trap portions of said previously molded and waste solid thermoplastic material between said stationary and said moving knives for cutting thereby into granules;
  - d. providing an apertured surface as a portion of said cylindrical boundary;
  - e. sweeping portions of said previously molded and waste solid thermoplastic material along said apertured surface with said moving knife thereby causing cut portions of said previously molded and waste solid thermoplastic material having granule size less than that of said apertures to pass therethrough for recycling via subsequent molding.
11. The method of claim 9 wherein said moving step further comprises orienting said second knife with a knife cutting edge parallel with the axis of a cylinder defined by said granulating zone and moving said knife circumferentially around said cylindrical boundary of said granulating zone to pass in proximity to said stationary knife and thereby trap portions of said previously molded

and waste solid thermoplastic material between said stationary and said moving knives for cutting thereby into granules.

12. The method of claim 10 wherein said moving step further comprises orienting said second knife with a knife cutting edge parallel with the axis of a cylinder defined by said granulating zone and moving said knife circumferentially around said cylindrical boundary of said granulating zone to pass in proximity to said stationary knife and thereby trap portions of said previously molded and waste solid thermoplastic material between said stationary and said moving knives for cutting thereby into granules.
13. The method of claim 11 wherein said introducing step further comprises introducing said previously molded and/or waste solid thermoplastic material into said cylindrical granulating zone in a direction aligned with the axis of said cylinder.
14. The method of claim 12 wherein said introducing step further comprises introducing said previously molded and/or waste solid thermoplastic material into said cylindrical granulating zone in a direction aligned with the axis of said cylinder.
15. The method of claim 9 wherein said axis of said cylinder is skew to vertical.
16. The method of claim 10 wherein said axis of said cylinder is skew to vertical.
17. A method for granulating previously molded and /or waste solid thermoplastic material for recycling through additional molding, comprising:
  - a. introducing said previously molded and/or waste solid thermoplastic material into a cylindrical granulating zone via a cylinder end;
  - b. providing at least one stationary knife, having length less than one quarter the diameter of said cylindrical granulating zone, at a cylindrical boundary of said granulating zone;

- c. moving at least one second knife, having length substantially that of said stationary knife, along said cylindrical boundary of said granulating zone to pass in proximity to said stationary knife and thereby trap portions of said previously molded and waste solid thermoplastic material between said stationary and moving knives for cutting thereby into granules;
  - d. providing an apertured surface as a portion of said cylindrical boundary;
  - e. sweeping portions of said previously molded and waste solid thermoplastic material along said apertured surface with said moving cutting knife thereby causing cut portions of said previously molded and waste solid thermoplastic material having granule size less than that of said apertures to pass therethrough for recycling via subsequent molding.
18. The granulator of claim 2 further comprising a hopper connected to and within said housing for gravity feeding of said solid scrap plastic material to be granulated downwardly to the interior of said apertured ring.
19. The granulator of claim 18 wherein said hopper is supported within said housing and is manually removable therefrom without use of tools.
20. The granulator of claim 19 wherein said hopper is vertically supported within said housing.
21. The granulator of claim 1 wherein said apertured ring rests on said baseplate
22. The granulator of claim 21 wherein said apertured ring and is manually removable from said baseplate by lifting without use of tools.
23. The granulator of claim 18 wherein said hopper retains said apertured ring in position.
24. The granulator of claim 23 wherein said hopper bears downwardly on said apertured ring.
25. The granulator of claim 1 wherein said stationary knife blades are perpendicular to said apertured ring interior

annular surface.

26. The granulator of claim 25 wherein said movable knife blades are at an angle of about 80 degrees to said apertured ring interior annular surface.
27. The granulator of claim 1 wherein said apertured ring is an integrally formed single piece of metal.
28. The granulator of claim 2 wherein said apertured ring is an integrally formed single piece of metal.
29. The granulator of claim 2 further comprising a hopper within said housing for gravity feeding of said solid scrap plastic material to be granulated downwardly to the interior of said apertured ring;
  - a. said hopper being vertically supported within said housing and manually removable therefrom without use of tools;
  - b. wherein said apertured ring rests on said baseplate and is manually removable from said baseplate by lifting without use of tools and said hopper retains said apertured ring in position by bearing at least partially downwardly on said apertured ring;
  - c. wherein said stationary knife blades are perpendicular to said apertured ring interior annular surface and said movable knife blades are at an angle of about 80 degrees to said apertured ring interior annular surface;.and
  - d. wherein said apertured ring is an integrally formed single piece of metal.
30. The method of claim 9 wherein said step of moving a second knife along said cylindrical boundary of said granulating zone to pass in proximity to said stationary knife and thereby trap portions of said previously molded and waste solid thermoplastic material between said stationary and said moving knives for cutting thereby into granules further comprises maintaining said second knife at an angle of about 80 degrees to said cylindrical boundary of said granulating zone during said movement.
31. The method of claim 30 wherein said step of providing an

apertured surface as a portion of said cylindrical boundary further comprises maintaining said apertured surface in position for the sweeping of portions of said previously molded and waste solid thermoplastic material therealong with said moving knife by bearing at least partially downwardly on a manually removable integral cylindrical ring member which includes said apertured surface.

32. The method of claim 10 wherein said step of moving a second knife along said cylindrical boundary of said granulating zone to pass in proximity to said stationary knife and thereby trap portions of said previously molded and waste solid thermoplastic material between said stationary and said moving knives for cutting thereby into granules further comprises maintaining said second knife at an angle of about 80 degrees to said cylindrical boundary of said granulating zone during said movement.
33. The method of claim 32 wherein said step of providing an apertured surface as a portion of said cylindrical boundary further comprises maintaining said apertured surface in position for the sweeping of portions of said previously molded and waste solid thermoplastic material therealong with said moving knife by bearing at least partially downwardly on a manually removable integral cylindrical ring member which includes said apertured surface.

34. A granulator including a housing; a motor connected to the housing; and a granulating assembly located within the housing receiving scrap plastic material from outside the housing, characterized by a rotor being connected to the shaft of the motor for rotation therewith; a first plurality of cutting knife blades being connected to the rotor at transverse extremities thereof with cutting edges of the blades parallel with the motor shaft; a base plate having the motor shaft rotatably journaled therewithin; a second plurality of cutting knife blades defining a circular array and being connected to the baseplate and upstanding relative thereto with cutting edges oriented parallel with the motor shaft and the first plurality of cutting knife blade edges; an apertured ring fitting around the second plurality of cutting knife blades; and at least one backplate being supported by the baseplate, positioned radially outboard of the apertured ring and axially substantially aligned therewith for deflecting for collection granules of plastic material, resulting from cutting action of the first and second pluralities of cutting knife blades, passing through the apertured.



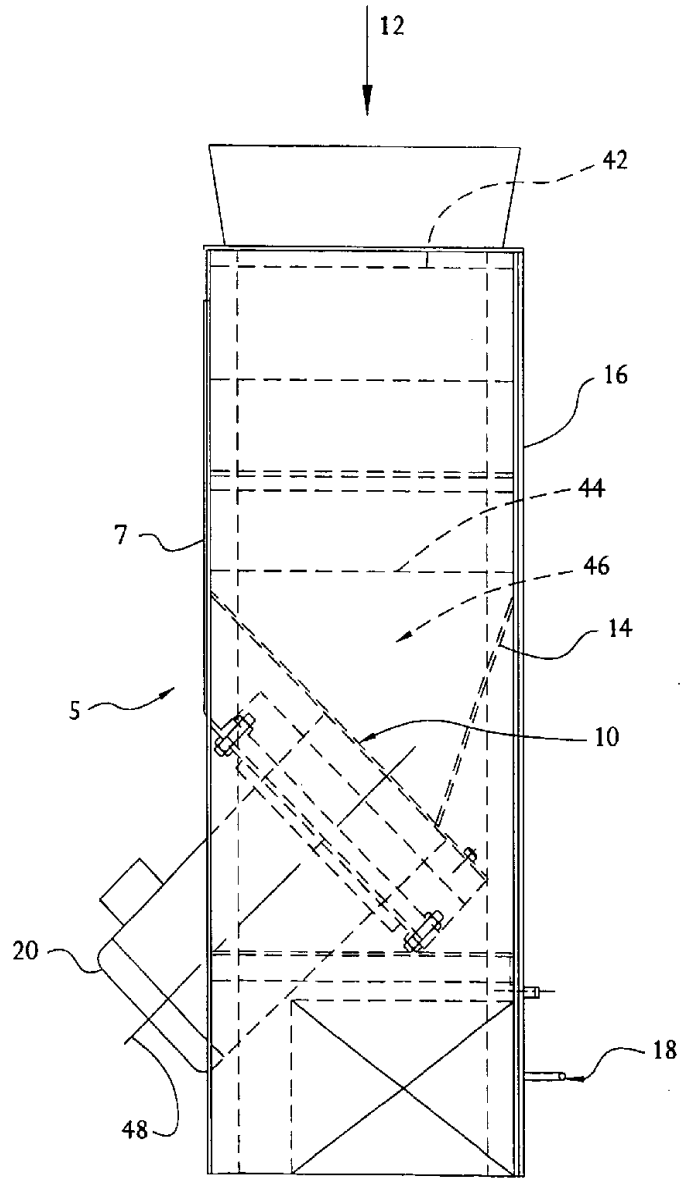

FIG. 1

SUBSTITUTE SHEET (RULE 26)

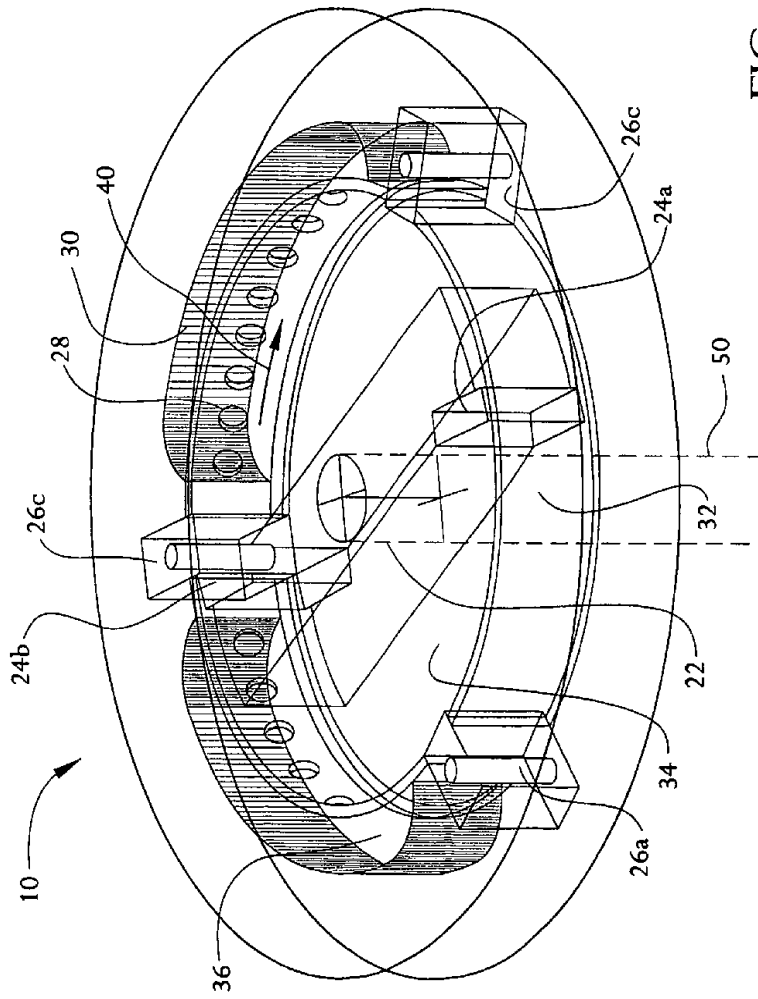

FIG. 2

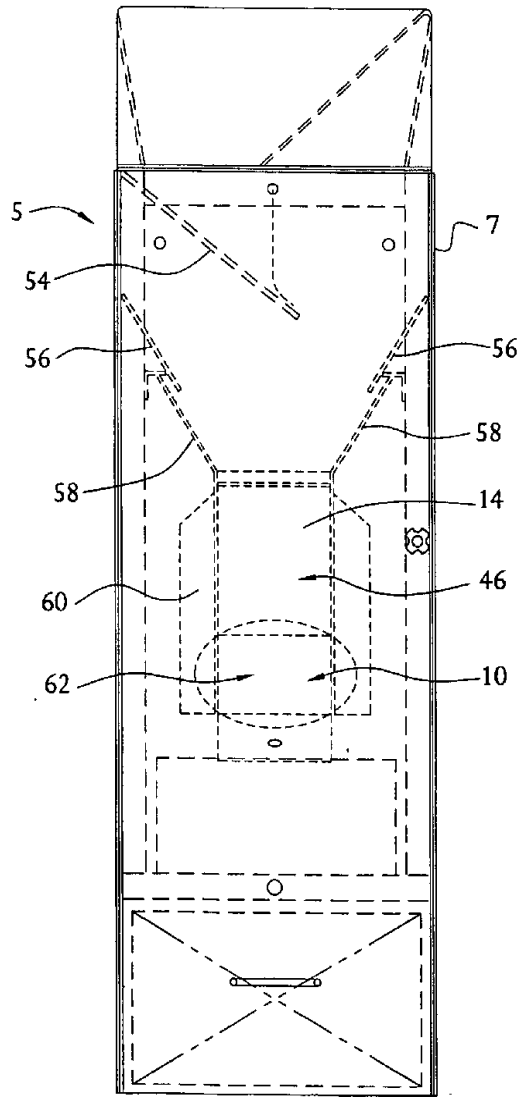

FIG. 3

SUBSTITUTE SHEET (RULE 26)

# INTERNATIONAL SEARCH REPORT

International Application No.  
PCT/US 99/04436

<b>A. CLASSIFICATION OF SUBJECT MATTER</b> IPC 6 B29B17/00 B29B9/00 B29B9/02 B02C18/44				
According to International Patent Classification (IPC) or to both national classification and IPC				
<b>B. FIELDS SEARCHED</b> Minimum documentation searched (classification system followed by classification symbols) IPC 6 B29B B02C				
Documentation searched other than minimum documentation to the extent that such documents are included in the fields searched				
Electronic data base consulted during the international search (name of data base and, where practical, search terms used)				
<b>C. DOCUMENTS CONSIDERED TO BE RELEVANT</b>				
Category *	Citation of document, with indication, where appropriate, of the relevant passages	Relevant to claim No.		
X	DE 94 09 906 U (TEB HOLDING) 8 December 1994  see claims 1-7; figure 1 ---	2, 9-14, 17-24, 28-33		
A	US 5 692 686 A (MOREAU PIERRE) 2 December 1997 see claim 1; figure 1 ---	1-33		
A	US 3 418 694 A (STRAUSS WILLIAM) 31 December 1968 see claim 1; figures 2-4 ---	1-33		
A	GB 2 120 969 A (NAT RES DEV) 14 December 1983 see claim 1; figure 3 ---	1-33		
-/--				
<input checked="" type="checkbox"/> Further documents are listed in the continuation of box C. <span style="margin-left: 100px;"><input checked="" type="checkbox"/> Patent family members are listed in annex.</span>				
* Special categories of cited documents :				
<table style="width: 100%; border: none;"> <tr> <td style="width: 50%; border: none;">                     "A" document defining the general state of the art which is not considered to be of particular relevance                      "E" earlier document but published on or after the international filing date                      "L" document which may throw doubts on priority claim(s) or which is cited to establish the publication date of another citation or other special reason (as specified)                      "O" document referring to an oral disclosure, use, exhibition or other means                      "P" document published prior to the international filing date but later than the priority date claimed                 </td> <td style="width: 50%; border: none;">                     "T" later document published after the international filing date or priority date and not in conflict with the application but cited to understand the principle or theory underlying the invention                      "X" document of particular relevance; the claimed invention cannot be considered novel or cannot be considered to involve an inventive step when the document is taken alone                      "Y" document of particular relevance; the claimed invention cannot be considered to involve an inventive step when the document is combined with one or more other such documents, such combination being obvious to a person skilled in the art.                      "&amp;" document member of the same patent family                 </td> </tr> </table>			"A" document defining the general state of the art which is not considered to be of particular relevance "E" earlier document but published on or after the international filing date "L" document which may throw doubts on priority claim(s) or which is cited to establish the publication date of another citation or other special reason (as specified) "O" document referring to an oral disclosure, use, exhibition or other means "P" document published prior to the international filing date but later than the priority date claimed	"T" later document published after the international filing date or priority date and not in conflict with the application but cited to understand the principle or theory underlying the invention "X" document of particular relevance; the claimed invention cannot be considered novel or cannot be considered to involve an inventive step when the document is taken alone "Y" document of particular relevance; the claimed invention cannot be considered to involve an inventive step when the document is combined with one or more other such documents, such combination being obvious to a person skilled in the art. "&" document member of the same patent family
"A" document defining the general state of the art which is not considered to be of particular relevance "E" earlier document but published on or after the international filing date "L" document which may throw doubts on priority claim(s) or which is cited to establish the publication date of another citation or other special reason (as specified) "O" document referring to an oral disclosure, use, exhibition or other means "P" document published prior to the international filing date but later than the priority date claimed	"T" later document published after the international filing date or priority date and not in conflict with the application but cited to understand the principle or theory underlying the invention "X" document of particular relevance; the claimed invention cannot be considered novel or cannot be considered to involve an inventive step when the document is taken alone "Y" document of particular relevance; the claimed invention cannot be considered to involve an inventive step when the document is combined with one or more other such documents, such combination being obvious to a person skilled in the art. "&" document member of the same patent family			
Date of the actual completion of the international search	Date of mailing of the international search report			
17 June 1999	07/07/1999			
Name and mailing address of the ISA	Authorized officer			
European Patent Office, P.B. 5818 Patentlaan 2 NL - 2280 HV Rijswijk Tel. (+31-70) 340-2040, Tx. 31 651 epo nl, Fax: (+31-70) 340-3016	Kofeod, J			

INTERNATIONAL SEARCH REPORT

International Application No  
PCT/US 99/04436

C. (Continuation) DOCUMENTS CONSIDERED TO BE RELEVANT		
Category *	Citation of document, with indication, where appropriate, of the relevant passages	Relevant to claim No.
A	EP 0 135 356 A (BICC PLC) 27 March 1985 see figure 1 ---	1-33
A	DE 295 09 271 U (WANNER TECHNIK GMBH) 24 August 1995 see figures 1-5 ---	1-33
A	DE 44 40 769 A (ERMAFA KUNSTSTOFFTECHNIK CHEMN) 23 May 1996 see figures 2,3 ---	1-33
A	DE 44 10 496 A (WEIMA APPARATEBAU GMBH) 28 September 1995 see figure 1 ---	1-33
A	DE 43 33 849 A (JUNGKUNZ MARIA) 9 March 1995 see figure 1 ---	1-33
A	DE 41 05 375 A (HEITLINGER KARL LEO) 27 August 1992 see figure 1 ---	1-33
A, P	DE 297 21 670 U (MM STYRO RECYCLING GMBH) 28 May 1998 see figures 4,5 ---	1-33
A	KORNMAYER H: "ANGUESSE UND AUSSCHUSS-TEILE MIT MUEHLEN WIEDERVERWERTEN" PLASTVERARBEITER, vol. 41, no. 7, 1 July 1990, page 96, 98, 100, 102 XP000161498 ---	1-33
A	HESS V: "CORRECT DESIGN OF GRANULATORS FOR INJECTION MOULDING PLANTS" PE PLAST EUROPE, no. 5, 1 October 1992, page 524, 525, 528 XP000329409 -----	1-33

Form PCT/ISA210 (continuation of second sheet) (July 1992)

# INTERNATIONAL SEARCH REPORT

Information on patent family members

International Application No PCT/US 99/04436
---

Patent document cited in search report	Publication date	Patent family member(s)	Publication date
DE 9409906 U	08-12-1994	NONE	
US 5692686 A	02-12-1997	FR 2732623 A	11-10-1996
US 3418694 A	31-12-1968	NONE	
GB 2120969 A	14-12-1983	DE 3313517 A	20-10-1983
EP 0135356 A	27-03-1985	NONE	
DE 29509271 U	24-08-1995	NONE	
DE 4440769 A	23-05-1996	NONE	
DE 4410496 A	28-09-1995	NONE	
DE 4333849 A	09-03-1995	NONE	
DE 4105375 A	27-08-1992	NONE	
DE 29721670 U	28-05-1998	NONE	