

C. SEITZ.  
TOY GUN.

APPLICATION FILED NOV. 30, 1904.

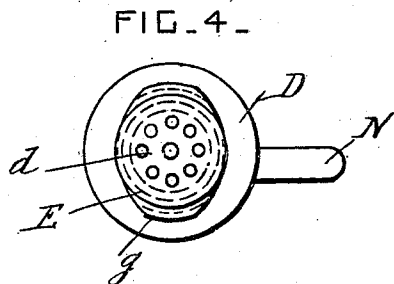
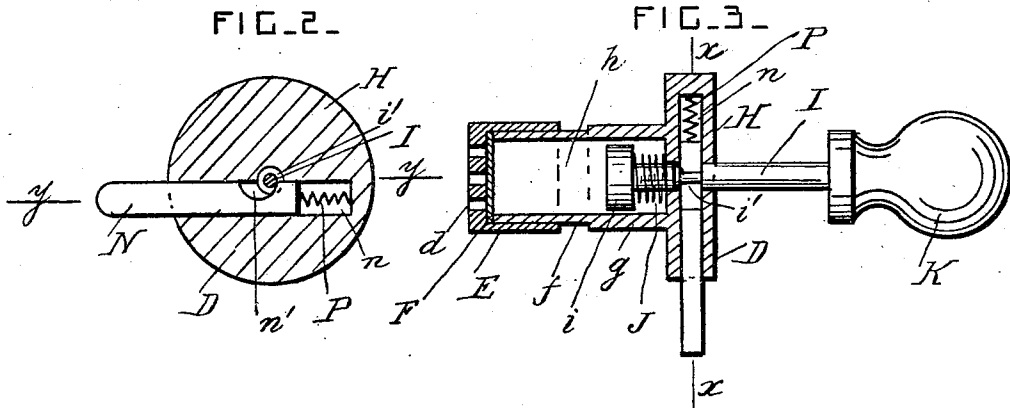
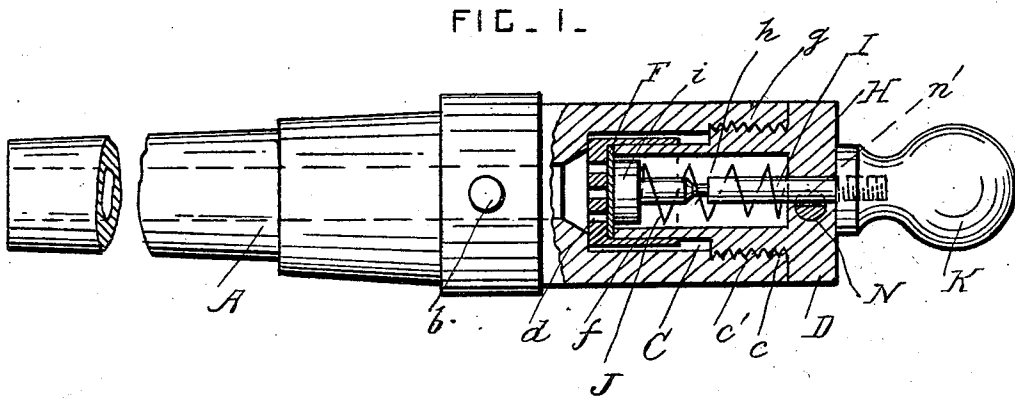

WITNESSES:

*J. Sprigg Pool*  
*Robt. G. Cissel.*

INVENTOR

*Charles Seitz*  
BY *Herbert W. Jenner.*  
Attorney

# UNITED STATES PATENT OFFICE.

CHARLES SEITZ, OF ALBANY, NEW YORK.

## TOY GUN.

No. 797,823.

Specification of Letters Patent.

Patented Aug. 22, 1905.

Application filed November 30, 1904. Serial No. 234,926.

*To all whom it may concern:*

Be it known that I, CHARLES SEITZ, a citizen of the United States, residing at Albany, in the county of Albany and State of New York, have invented certain new and useful Improvements in Toy Guns; and I do hereby declare the following to be a full, clear, and exact description of the invention, such as will enable others skilled in the art to which it appertains to make and use the same.

This invention relates to toy guns; and it consists in the novel construction and combination of the parts by means of which the firing is effected, as hereinafter fully described and claimed.

In the drawings, Figure 1 is a side view of the gun, partly in section. Fig. 2 is a cross-section taken on the line  $x x$  in Fig. 3. Fig. 3 is a sectional plan view taken on the line  $y y$  in Fig. 2. Fig. 4 is an end view of the breech-block and thimble removed from the gun.

A is the barrel of the gun, which is provided with trunnions  $b$  and is mounted and pivoted in any approved carriage, so that it may be tilted to various angles and turned around on a vertical axis or operated in any other approved manner.

C is the breech-chamber of the gun, and  $c$  is an enlargement at the rear end portion of the breech-chamber, which is provided with grooves or screw-threads extending part way around its internal periphery.

D is the breech-block, which is provided with a cylindrical clamping-tube  $f$ , which projects at its front end.

E is a thimble which is slipped over the end portion of the clamping-tube and which is provided with a perforated bottom  $d$ , which rests against the bottom of the breech-chamber. The external surface of this thimble is preferably knurled or corrugated.

F is an explosive cap or detonator of any approved make. This cap is pressed against the perforated bottom of the thimble and is held securely in an upright position by means of the end of the clamping-tube  $f$ , which bears against the rim of the cap.

The breech-block is provided with an oval portion  $g$ , having grooves or partial screw-threads on its largest part which engage with the grooves or partial screw-threads  $c'$  of the breech-chamber. The breech-block is slipped into the breech-chamber and is secured by turning it around about half a revolution. The breech-block is also provided with a head H, which bears against the end of the breech-

chamber. A chamber  $h$  for the firing-pin is formed inside the breech-block and in the clamping-tube  $f$ .

I is the firing-pin, provided with a head  $i$ , which strikes the cap.

J is a spiral spring arranged in the chamber  $h$  between the heads H and  $i$ .

The firing-pin is slidable in a hole in the head H, and K is a knob screwed on the projecting end portion of the firing-pin and affording a means for retracting it against the pressure of the firing-spring. The firing-pin is also provided with a circumferential groove  $i'$  at about the middle of its length for the trigger to engage with.

N is the trigger, which is slidable in a chamber  $n$ , formed crosswise of the axis of the firing-pin in the head H.

P is a spring in the chamber  $n$ , which presses the trigger outward, so that it engages with the groove in the firing-pin when the said firing-pin is retracted, as shown in Fig. 3. The trigger is provided with a notch  $n'$  upon one side, and when the said trigger is pushed inward against its spring this notch permits the firing-spring to propel the firing-pin forcibly against the cap. The cap is exploded and the smoke and other products of combustion are projected through the perforations of the thimble-bottom and any light projectile in the barrel of the gun is fired out.

What I claim is—

1. In a toy gun, the combination, with a barrel provided with a breech-chamber, of a removable breech-block provided with means for connecting it to the barrel, a thimble for holding the cap slidable over the front end portion of the breech-block, and a slidable firing-pin in the breech-block.

2. In a toy gun, the combination, with a barrel provided with a breech-chamber, of a removable breech-block provided with means for securing it to the barrel and having a projecting clamping-tube at its front end, a thimble having a perforated bottom and slidable over the said tube and holding the cap against the front end of the said tube, and a slidable firing-pin in the breech-block.

3. In a toy gun, the combination, with a barrel provided with a breech-chamber, of a removable breech-block provided with means for securing it to the barrel and having a projecting clamping-tube at its front end, a thimble having a perforated bottom and slidable over the said tube and holding the cap against the front end of the said tube, a firing-pin slidable

in the said tube and breech-block and provided with a head and a circumferential groove, a firing-spring bearing against the said head, and a spring-pressed trigger slidable in the breech-block crosswise of the firing-pin and engaging with the said groove when the firing-pin is retracted.

In testimony whereof I have affixed my signature in the presence of two witnesses.

CHARLES SEITZ.

Witnesses:

ALBERT C. MÜNZ,  
RALPH HAMMERSLEY.