

Oct. 20, 1959

V. APPENZELLER

2,908,964

PRESSURE TREATMENT OF MATERIAL

Filed Jan. 18, 1957

2 Sheets-Sheet 1

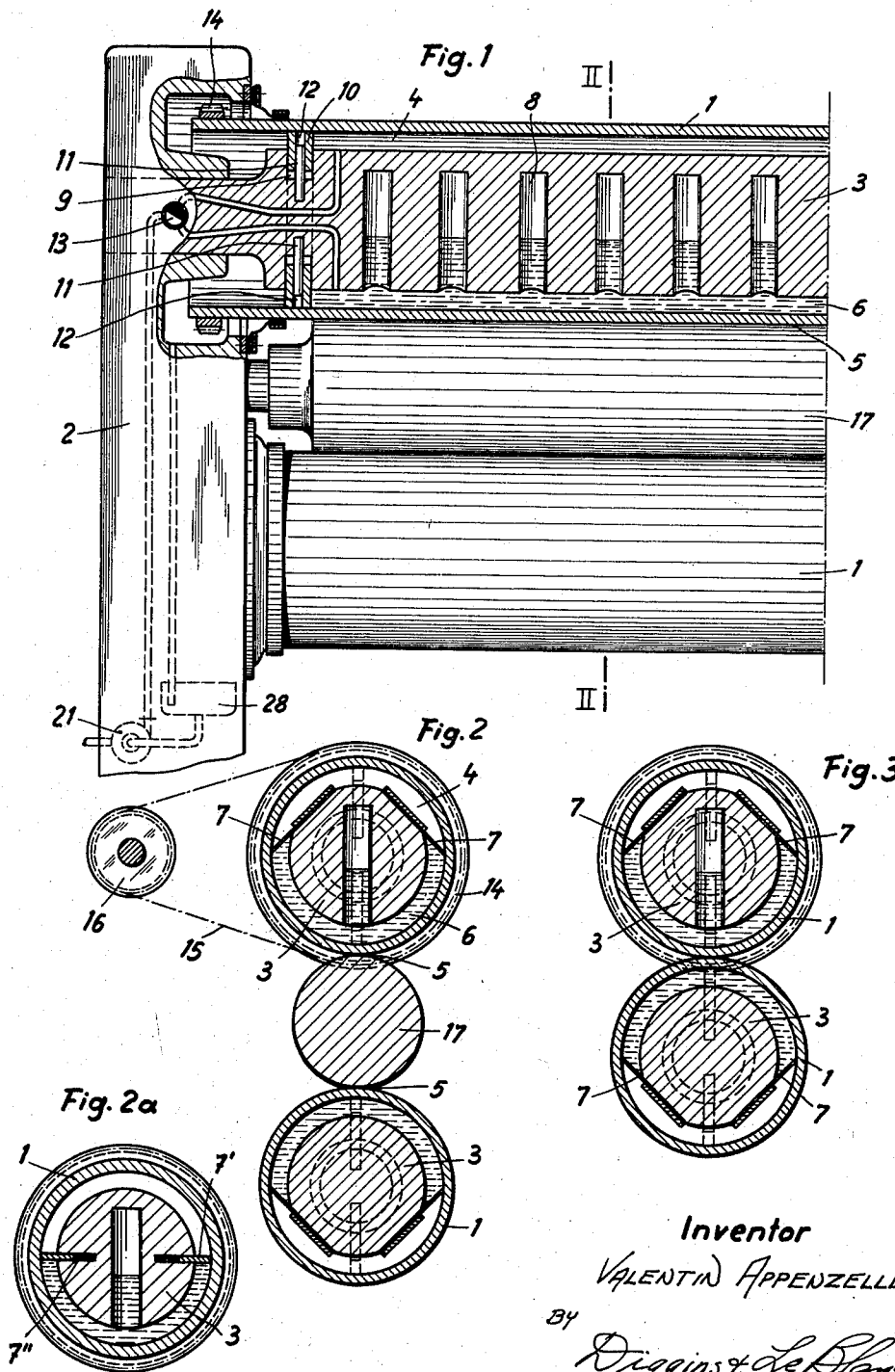

Inventor
VALENTIN APPENZELLER
BY
Diggins & deBlanc
ATTORNEYS

Oct. 20, 1959

V. APPENZELLER

2,908,964

PRESSURE TREATMENT OF MATERIAL

Filed Jan. 18, 1957

2 Sheets-Sheet 2

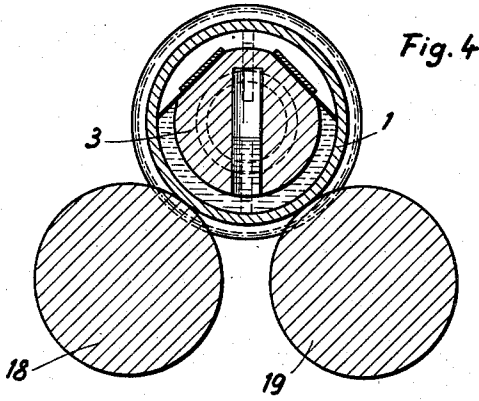

Fig. 4

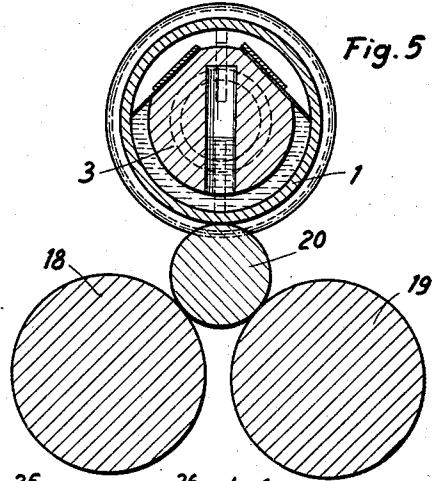

Fig. 5

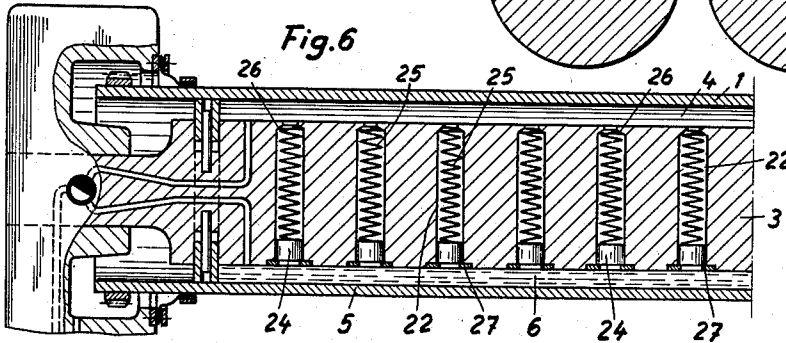

Fig. 6

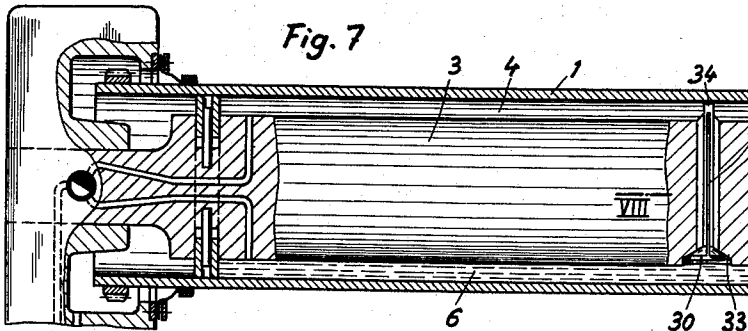

Fig. 7

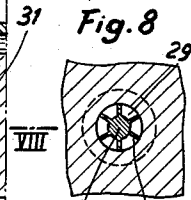

Fig. 8

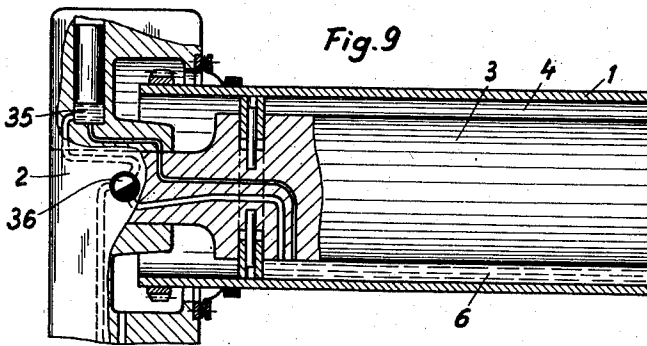

Fig. 9

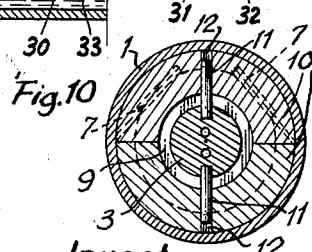

Fig. 10

Inventor

VALENTIN APPENZELLER

BY *Deppis & L. Blane*
ATTORNEYS

1

2

2,908,964

PRESSURE TREATMENT OF MATERIAL

Valentin Appenzeller, Krefeld, Germany, assignor to
Eduard Kusters, Krefeld, Germany

Application January 18, 1957, Serial No. 634,996

21 Claims. (Cl. 29—110)

The invention relates to a roller for the pressure treatment of material webs, for smoothing and embossing paper and other materials, for squeezing moisture from textiles, for calendering, for drawing plastic and rubber sheets and the like, for other pressing procedures and for rolling materials to a determined thickness. More particularly the invention relates to a roller which consists of a rotatable drum or tube-like hollow body forming the roller periphery, and adapted to rotate about a rigid stationary core which bears the load so as to provide a roller with which a uniform pressure is possible over the whole length of the roller.

It is well known that rollers for the pressure treatment of material webs undergo a deflection towards the side opposite the point of action of the roller which adversely affects the ability of the roller to exert uniform pressure along its whole length when it is pressed against a counter roller or a support.

Various proposals are already known for obviating this drawback one of which is the idea of curving the roller. Here there is the drawback that each curve can take into account only a certain magnitude of pressure and for each magnitude of pressure another roller is necessary. Another expedient involves the use of support rollers which are distributed on the side away from the point of action of the roller along the entire length of the roller. These undergo separate pressure loads and produce uniform pressure along the whole length of the roller while avoiding a deflection. However this is unfavourable inasmuch as it involves the use of a comparatively large number of constructional parts and in squeezing moisture from textiles tends to soil the textiles as well as form dirt and slub catchers which render a cleaning of the apparatus necessary at comparatively short intervals and adversely influences the working speed.

The present invention is based on the idea of combining the working or acting roller periphery with a member which takes the pressure load so that any deflection of the member taking the pressure load does not influence the operating roller periphery.

According to the invention a hollow body forming the roller periphery is arranged to float around a core and the intermediate space existing between the core periphery and the inner periphery of the hollow body on the side towards the operating point of the roller is filled with a pressure fluid, which term may include a medium exercising a gaseous pressure. Means is provided to prevent this fluid from flowing into the intermediate space lying on the side of the roller and core away from the working point. The result of this is that the hollow body which forms the roller cover and which exercises pressure on the material web to some extent floats on a fluid on the side exercising the pressure. The tube-like body may consist of any suitably resilient material such as steel, flexible as the case may require, or of elastic material, and also may comprise synthetic material with or without flexible or elastic properties such as polyamides and super-

polyamides. As a rule steel is selected as a material for the core which may be of any suitable cross-section.

The roller of the invention exercises along its whole length a uniform pressure on a counter roller or another support as the fluid pressure is spread uniformly on all sides without requiring special additional measures to ensure the pressure being uniform. Deflections of the stationary core have no influence on the satisfactory contact of the tube body on its counter surface. Even if the counter surface undergoes deflections, neither the uniform pressure on the whole length of the roller nor the satisfactory contacting on the counter surface is distributed since the tube-like body follows the deflections.

It is advisable to provide the tube-like body with a resistance moment less than the resistance moment of the rigid counter roller in order to insure that the tube-like body will always follow the deflections of the counter roller.

The fluid in the tube body is preferably air cushioned to provide the additional advantage that even with unevennesses in the material web, the roller can yield elastically without appreciably increasing the fluid pressure.

The air cushion may be provided in the form of recesses constituting blind-end bores distributed uniformly on the length of the core in cross direction to its axis. The fluid penetrates into the blind end bores to a certain extent and compresses the air located therein.

According to another embodiment of the invention the air cushion consists of bores passing perpendicularly through the core uniformly along its length from one side to the other. Pistons are arranged in these bores on the side of the core immersed in the fluid and are urged toward the fluid by springs. Here the spring tension corresponds to the highest pressure to be exercised on the roller.

In order to prevent excessive deflection of the core it may be provided with a cross bore connecting its immersed side to its opposite fluid free side through a check valve which normally cuts off the passage of fluid from the core side immersed in the fluid to the core side free of fluid but which permits fluid flow on excessive deflection over to the other core side.

One important advantage of the roller of the invention resides in the fact that by means of a comparatively slight fluid pressure a large specific pressure is produced on the roller edge acting on the material web as the magnitude of the inner periphery of the tube-like body stressed by the pressure fluid determines the magnitude of the specific pressure on the material web to be treated.

The fluid led into the roller may also serve for heating or cooling purposes.

The drawing illustrates one embodiment of the invention on an apparatus for the squeezing out of the moisture of textiles without the invention being limited to this use.

Fig. 1 is a partial front view of the apparatus with the upper roller longitudinally sectioned.

Fig. 2 is a section on line II—II of Fig. 1,

Fig. 2a shows a cross section through an upper roller with packing members of another construction.

Fig. 3 shows another roller combination in section corresponding to Fig. 2.

Figs. 4 and 5 show further possibilities of roller arrangements in cross section,

Fig. 6 is a longitudinal section corresponding to Fig. 1 showing a roller with an air cushion constructed in another manner.

Fig. 7 is a longitudinal section through the roller showing a method for the prevention of excessive deflection.

Fig. 8 is a section through the valve on line VIII—VIII in Fig. 7.

Fig. 9 is a longitudinal section through a roller without an air cushion showing the use of a fluid accumulator.

3

Fig. 10 is a section on the line X—X of Fig. 1.

In the arrangement shown in Figs. 1 and 2, both the upper roller and the under roller consist of a tube-like hollow body 1 which need only have a comparatively thin wall thickness and which can consist of any suitable material such as steel, a flexible or elastic material, a synthetic material on a suitable base such as, for example, polyamide and superpolyamide. The tube-like body 1 is arranged on a rigid core 3 which may be steel mounted stationarily in the stand 2. All about this core there is an intermediate space or peripheral distance 4 which is selected in size in accordance with the requirements of use of the rotor. The tube-like body 1 is rotatable around the rigid core 3.

On the side of the roller, towards the acting point 5, that is, the point exercising pressure on the material web to be treated, the space between the tube-like body and the core 3 is filled with pressure fluid which may come from a suitable source for example a pump 21. Opposite the space between the tube-like body 1 and the core away from the acting point of the roller the space is shut off from the liquid by a suitable packing which may be formed by packing strips 7 of metal or other material. The packing strips 7 are located on the core 3 and lie with their free ends on the inner periphery of the tube-like body 1. Of course the packing may also be formed in another manner such as for example by synthetic material or leather strips the ends of which lie on the inner periphery of the tube-like body and are bent over like a sleeve. A completely tight shut off of the fluid is not absolutely necessary as some fluid flow does not adversely affect the operation of the roller.

According to Fig. 2a the shut off packings consist of discs 7' which are arranged in the core 3 lying diametrically opposite one another and of openings 7'' said packings being pressed against the inner peripheral surface of the hollow body.

The tube-like body 1 has a smaller resistance moment than the solid roller 17 co-operating with it.

In the core 3 of the upper roller in the embodiment of Fig. 1 blind end bores 8 are provided uniformly along the length of the core. These extend from the side of the core towards the acting point 5 of the roller crosswise to the longitudinal axis of the roller. The blind end bores fill up partly with fluid which compresses the air located above the level of the liquid. It is possible to provide for the air cushion so formed an absorption possibility.

According to another embodiment of the invention shown in Fig. 6, instead of the blind end bores 8 in Fig. 1, the bores 22 are provided which likewise extend from the side of the core 3 towards the acting point 5 of the roller which is immersed in the fluid 6 crosswise to the longitudinal axis of the roller. The bores connect two sides of the core. In the bores 22, on the side of the core immersed in the fluid there are arranged pistons 24 which are free to move in the bores. Springs 25 are arranged in the bores between the pistons and shoulders 26 formed by a narrowing of the bores. The springs tend to push the pistons out and have a tension which corresponds to the greatest normal pressure exercised by the roller. The pistons are held in the bores by the annular discs 27.

Referring to Figs. 7 and 8 there is shown a means for preventing excessive deflection of the core. The core 3 is provided with a cross bore 29 which connects the core side immersed in fluid 6 with the opposite core side which is free from fluid. A check valve is inserted in the bore end and consists of a plate 30 and shaft 31. The shaft is guided by vanes 32 in the bore. The plate 30 is normally pressed against seat 33 by the pressure of the fluid 6 and closes the bore. The end 34 of shaft 31 projects into the space of the tube-like hollow body 1 which is free of fluid. When the deflection of the core is too great the end 34 of the valve shaft engages the inner periphery of the hollow body 1 and the plate 30 is lifted from the seat 33 so that fluid can flow through the bore 29.

4

In the embodiment of the roller shown in Fig. 7 no air cushion is provided, although it will be understood that an air cushion may be provided if desired.

An annular disc 10 is mounted on each end of the roller in a peripheral groove. The outer periphery of the disc engages the inner periphery of the tube-like body 1 and the inner diameter of the disc permits play between the disc and core. Rods are arranged in core 5 crosswise to the longitudinal axis of the roller and these rods engage radial bores 12 of the annular discs 10 to limit the radial movability of the annular discs in a direction crosswise to the longitudinal axis of the roller. The discs 10 thus provide a seal between the core 3 and cylinder 1 despite movement therebetween. These discs may be mounted in any suitable manner such as in halves 10 as shown in Figure 10. The disc halves may be fitted into the groove 9 before the cylinder 1 is pushed over the core 3.

The pressure fluid 6 may be reversibly positioned by means of control cock 13 which permits the fluid to flow from the roller side towards the acting point of the roller to the roller side away from the acting point in order to lift the hollow body opposite the counter roller or counter surface co-operating with it.

A collecting vessel 28 may be provided in stand 2 for the leaking fluid which emerges from the ends of the rollers past the packing rings 10. The fluid is continuously led from the collecting vessel or sump back to the roller by a pump 21.

The tube-like body 1 may, for example, be driven via chain wheel 14, chain 15 and chain wheel 16 located on a suitable driving apparatus. It is also possible to drive only the solid roller 17 and drive the tube-like body 1 by friction therefrom.

In the embodiment shown in Figs. 1 and 2 there is arranged between two rollers constructed according to the invention a solid roller 17 of comparatively small diameter which may be rigid or which may have a resilient outer surface. In this case only the upper roller is provided with the air cushion formed by the blind end bores 8 as the air could escape upward from blind holes provided in the core of the lower roller. An air cushion according to Fig. 6 could be provided if desired.

According to Fig. 3 upper and lower rollers constructed according to Fig. 2 cooperate.

As Fig. 4 shows, a roller according to the invention may also cooperate with two solid rollers 18 and 19 one of which is arranged on each side of the lower side of the upper roller.

Fig. 5 illustrates an arrangement corresponding to Fig. 4 in which between the two rollers 18 and 19 and the upper roller a solid roller 20 of comparatively small diameter is arranged.

Where desired it is possible to provide a slide support in the stand against which the ends of the roller contact in order to take the forces acting in the axial direction of the roller.

Figure 9 shows another embodiment of the invention wherein a pressure accumulator 35 is provided in the stand 2 which supports the roller. By adjustment of the control cock 36 the pump 21 supplies the accumulator 35 from which the roller is fed with fluid.

Where the roller is used for the rolling of rolled material to a certain thickness the distance between the working rollers corresponding to this thickness is adjusted and the fluid acts only as a means for transmitting pressure originating from the rolled material to the core.

The invention is not limited to the embodiment shown or the details for this embodiment but also comprises variations coming within the scope of the invention.

What I claim is:

1. A roller for applying pressure along one side thereof comprising, a stationary core, a tube-like cover mounted to rotate about said stationary core, said core being of such a size as to define with said cover an intermediate

space therebetween, sealing and bearing means at each end of said space, means separating said intermediate space into a first compartment adjacent said pressure applying side and a second compartment on the opposite side of said roller, and fluid in said first compartment.

2. A roller as set out in claim 1 including a pressure relief means connected to said intermediate space for relieving pressure applied to said fluid.

3. A roller as set out in claim 2 wherein said pressure relief means comprises pocket means in said core containing a compressible fluid.

4. A roller as set out in claim 3 wherein said pocket means comprises a plurality of bores in said core, each bore having one closed end.

5. A roller as set out in claim 4 wherein said bores are distributed uniformly along the length of the core and extend substantially at right angles to the axis of the core.

6. A roller as set out in claim 2 wherein said pressure relief means comprises a plurality of bores in said core, pistons in said bores, and springs in said bores urging said pistons against said fluid.

7. A roller as set out in claim 6 wherein said bores extend transversely through said core.

8. A roller as set out in claim 6 wherein said springs have a tension corresponding to the highest normal pressure to be exerted by the roller.

9. A roller as set out in claim 2 wherein said pressure relief means is external of said roller and is connected thereto by conduit means.

10. A roller as set out in claim 9 wherein said pressure relief means comprises a pressure accumulator external of said roller and connected to said intermediate space by conduit means.

11. A roller for applying pressure along one side thereof comprising, a stationary core, a tube-like cover mounted to rotate about said stationary core, said core being of such a size as to define with said cover an intermediate space therebetween, sealing and bearing means at each end of said space, means separating said intermediate space into a first compartment adjacent said pressure applying side and a second compartment on the opposite side of said roller, and a substantially incompressible fluid in said first compartment.

12. A roller as set out in claim 11 including pressure relief means enclosing a compressible fluid which is compressible to relieve pressure applied to said incompressible fluid.

13. A roller for applying pressure along one side thereof comprising a stationary core, a resilient tube-like cover mounted to rotate about said core, said core being of such a size as to define with said cover an intermediate space therebetween, sealing and bearing means at each end of said space, means separating said space into a first compartment and adjacent said pressure applying side and a second compartment on the opposite side of said roller, and means for introducing fluid into said first compartment.

14. A roller as set out in claim 13 including pressure relief means connected to said intermediate space for relieving pressure applied to said fluid.

15. A roller as set out in claim 1 including a valve in said roller, said valve having actuating means establishing fluid communication between said first and second compartments when the deflection of said core exceeds a predetermined amount.

16. A roller as set out in claim 15 wherein said valve includes a bore extending through said core from said first to said second compartment and having a valve seat associated therewith, a valve member seated on said seat, and a shaft extending through said bore and connected to said valve member, said shaft being engageable by said tube-like cover in said second compartment whereby on excessive deflection of said core the cover contacts the shaft and lifts the valve member from the seat.

17. A roller as set out in claim 1 wherein said means separating said intermediate space into first and second compartments comprises strips extending longitudinally through said intermediate space from opposite sides of said core and engaging the inner surface of said cover to form a substantially fluid tight seal therewith.

18. A roller as set out in claim 17 wherein said strips are packing strips and form angles of less than 90° with a plane extending through the axis of said core and the pressure applying side of said roller.

19. A roller as set out in claim 18 wherein said core has peripheral grooves at the ends thereof, packing washers mounted in said grooves with clearance between the aperture in said washers and said grooves to permit radial movement therebetween, the outer peripheries of said washers contacting the inner surface of said cover to form a substantially fluid tight seal therewith and to limit radial movement of said cover.

20. A roller as set out in claim 1 wherein said core has peripheral grooves at the ends thereof, packing washers mounted in said grooves with clearance between the aperture in said washers and said grooves to permit radial movement therebetween, the outer peripheries of said washers contacting the inner surface of said cover to form a substantially fluid tight seal therewith and to limit radial movement of said cover, radial guide pins mounted in said grooves and extending substantially perpendicular to the axis of said core, and bores in said washers receiving said guide pins.

21. A roller as set out in claim 1 including means for filling said second compartment with fluid under pressure.

References Cited in the file of this patent

UNITED STATES PATENTS

1,702,140	Topham	Feb. 12, 1929
2,648,122	Hornbostel	Aug. 11, 1953
2,685,548	Drozowski	Aug. 3, 1954