

March 24, 1942.

P. H. STEBBING ET AL

2,277,165

TOILET VENTING DEVICE

Filed Sept. 8, 1941

2 Sheets-Sheet 1

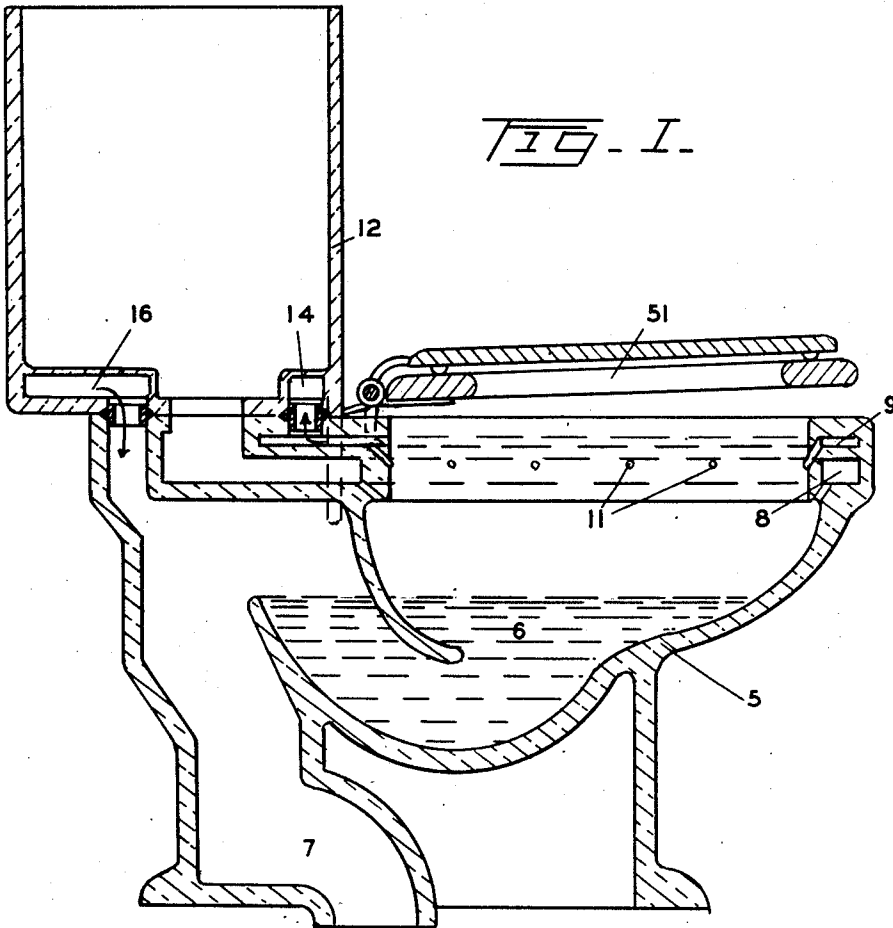

FIG. I.

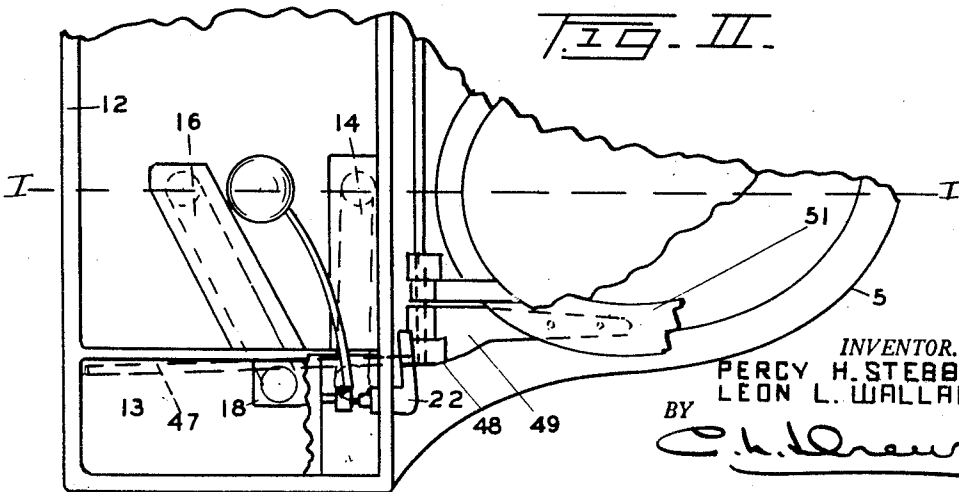

FIG. II.

INVENTOR.
PERCY H. STEBBING
LEON L. WALLACE

BY
C. H. Drew

March 24, 1942.

P. H. STEBBING ET AL

2,277,165

TOILET VENTING DEVICE

Filed Sept. 8, 1941

2 Sheets-Sheet 2

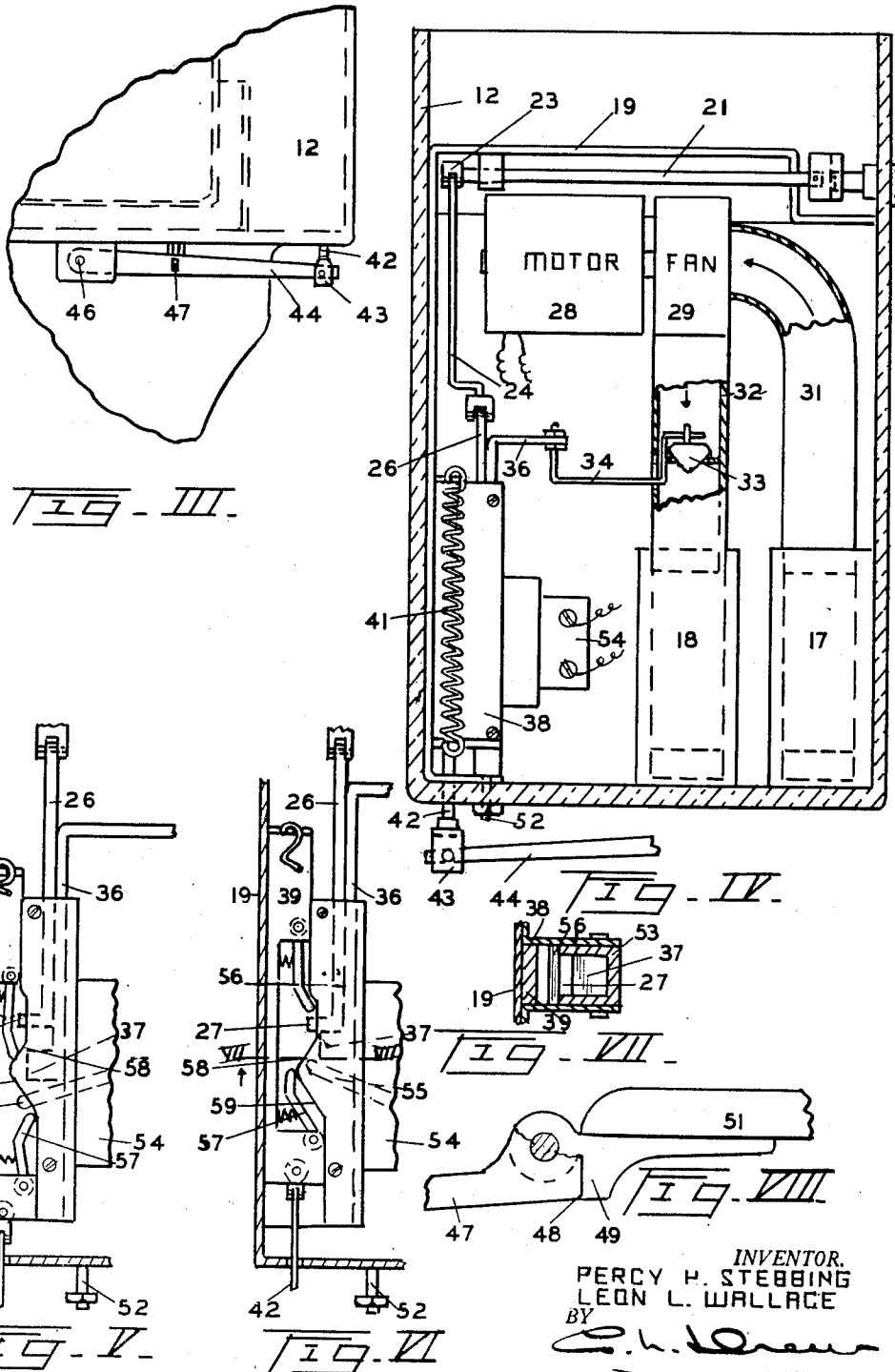

INVENTOR,
PERCY H. STEBBING
LEON L. WALLACE

BY

[Signature]

UNITED STATES PATENT OFFICE

2,277,165

TOILET VENTING DEVICE

Percy H. Stebbing and Leon L. Wallace,
Petaluma, Calif.

Application September 8, 1941, Serial No. 410,012

2 Claims. (Cl. 4—213)

This invention relates to improvements in toilet venting devices and has particular reference to a device whereby objectionable odors are drawn from the toilet bowl and discharged into the sewer.

A further object of the invention is to produce a device of this character which is automatic in its operation.

A further object of the invention is to produce a device of this character which may be incorporated in the standard plumbing fixtures without materially altering their appearance and at a reasonable cost.

Other objects and advantages will be apparent during the course of the following description.

In the accompanying drawings forming a part of this specification and in which like numerals are employed to designate like parts throughout the same,

Fig. I is a cross sectional view taken on the line I—I of Fig. II;

Fig. II is a fragmentary top plan view of a toilet having my device applied thereto;

Fig. III is a fragmentary detailed view, showing the actuating lever mechanism;

Fig. IV is an enlarged detailed view of the operating mechanism of my device, showing the tank in cross section;

Fig. V is a fragmentary detailed view of the operating switch in "off" position;

Fig. VI is a view similar to Fig. V, showing the switch in "on" position;

Fig. VII is a cross sectional view taken on the line VII—VII of Fig. VI; and

Fig. VIII is a fragmentary detailed view, showing the seat hinge.

Very few toilets are vented and, consequently, objectionable odors arise therefrom. Even those which are vented do not effectively carry off these odors.

We have, therefore, devised a simple arrangement which may be installed at the end of the flush tank and actuated by the pivotal action of the seat so that a motor driven blower will draw objectionable odors from the toilet bowl and deliver them into the discharge portion of the bowl.

In the accompanying drawings wherein for the purpose of illustration is shown a preferred embodiment of our invention, the numeral 5 designates the ordinary toilet bowl having the customary water seal 6 and discharge 7. The customary flushing ring is shown at 8, and above this flushing ring we form an air vent 9 from which openings 11 connect with the interior of the bowl. Mounted on the bowl is a tank 12

having a chamber 13 formed in one end thereof and it is within this chamber that we place the operating mechanism of our ventilating device.

Referring to Figs. I and II, it will be noted that a passage 14 connects with the air vent 9, and a passage 16 communicates with the discharge 7. These passages also enter the chamber 13 and terminate in upstanding bosses 17 and 18, respectively. Mounted in the chamber 13 is a bent frame 19, the upper portion of which forms a cover for the chamber 13 and also supports a rotatable rod 21 in alignment with the flushing handle 22, to which it is removably connected. This rod 21 is connected by a lever 23 to a pull rod 24, which is in turn connected to a slider 26 having a nose 27, the purpose of which will be later seen. This frame 19 also supports a motor 28 and a fan 29, which is connected to the motor. An intake pipe 31 connects the intake of the fan 29 to the passage 14 in the boss 17. A pipe 32 connects the exhaust of the fan to the passage 16 and the boss 18. A valve 33 is positioned in the pipe 32 and is actuated by an adjustable rod 34 carried upon the valve operator rod 36. This valve operator rod terminates in a bent nose 37, the purpose of which will be later seen.

Referring now to Figs. V and VI, it will be noted that the plate 38 of the control mechanism has been removed so as to disclose an actuator 39, there being a pair of springs 41, only one of which is shown, for normally maintaining the actuator 39 in the position of Fig. V. The lower end of this actuator is connected by a rod 42 to a clevis 43 engaging the end 44 of a lever pivoted as at 46 to the bottom of the tank 12. This lever is actuated by a seat bar 47 (see Fig. VII), which seat bar has a face 48 which is engaged by a lug 49 formed upon the seat 51. The purpose of this arrangement will be later described.

The frame 19 is held to the tank by a lug 52 (see Fig. IV). The slider 26 and the valve operator rod 36 are mounted in the U-shaped member 53, upon which is positioned a switch casing 54 having a switch toggle lever 55. Spring actuated dogs 56 and 57 are pivotally mounted in the actuator 39 and have their noses so arranged that they will ride upon cam surfaces 58 and 59, respectively.

The result of this construction is that when the parts are assembled and the seat is in the position of Fig. I, the actuating mechanism will be as shown in Figs. IV and V. Now assuming that the seat is depressed, the first

action will be to move the seat bar 47 to raise the lever end 44, and pushing upwardly on the rod 42 and actuator 39 against the tension of the springs 41. This will cause the nose of the dog 57 to engage the end of the switch toggle 55, pushing the same to the dotted line position of Fig. VI, the dog riding on the cam 58 out of the path of the return movement of the switch toggle 55. This upward movement of the switch toggle will also push upwardly on the nose 37 of the valve operator rod 36 and will raise the valve 33 so that as soon as the motor and fan start to operate, air will be drawn through the pipe 31, channel 14 and air vent 9 and discharged through the fan past the valve 33, into the channel 16 and into the discharge 7.

Should a person desire to flush the toilet while the seat is still depressed, the flush lever 22 is actuated in the customary manner, with the result that downward movement of the slider 26 will push downwardly on the nose of the valve operator rod 36 and in turn engage the toggle lever 55, cutting off the motor and fan, closing the valve 33 and flushing the toilet.

If the user of the toilet does not use the hand actuator flush lever, then the act of releasing the toilet seat will permit the springs 41 to return the actuator from the position of Fig. VI to that of Fig. V, with the result that the downward movement will cause the dog 56 to engage the end 27 of the slider 26 and will thus actuate the flushing mechanism to which the slider is connected, will close the valve 33 through the valve operator rod 36 and will actuate the switch toggle 55 to close off further action of the motor and fan.

Thus it will be seen that we have devised a mechanism which will accomplish all the objects above set forth.

It is to be understood that the form of our invention herewith shown and described is to be taken as a preferred example of the same and that various changes relative to the mate-

rial, size, shape and arrangement of parts may be resorted to without departing from the spirit of the invention or the scope of the subjoined claims.

Having thus described our invention, we claim:

1. In a device of the character described, in combination with a toilet bowl, of a tank positioned thereon, a seat pivoted to said bowl, a chamber formed in said tank, passages connecting said chamber and said bowl to a discharge from said bowl, a motor driven fan interposed between said bowl and said discharge, an actuating mechanism for controlling the actuation of said fan and comprising an actuator having a pair of opposed pivoted dogs, a flushing actuated slider having a nose in alignment with one of said dogs, a switch toggle in alignment with the other of said dogs, cam means for alternately moving said dogs into engagement with said nose and said toggle, and a seat operated lever for moving said actuator against a spring tension.

2. A device to actuate a toilet ventilating mechanism for a toilet having a bowl, flushing tank, a blower and a pivoted seat and comprising in its construction a U-shaped member, having cams formed thereon, said U-shaped member having a flushing actuating slider, and a valve operating rod slidable therein, said slider and said rod each having a nose formed thereon, a switch lever carried by said U-shaped member and in alignment with the movement of said rod, an actuator moved by the pivotal action of said seat and slidably held against said U-shaped member, a pair of opposed pivoted dogs carried by said actuator, and adapted to ride on said cams, whereby operation of said actuator will alternately move said dogs into engagement with said switch lever and said nose to cause movement thereof to effect ventilation of said bowl.

PERCY H. STEBBING.
LEON L. WALLACE.