



INTERNATIONAL APPLICATION PUBLISHED UNDER THE PATENT COOPERATION TREATY (PCT)

<p>(51) International Patent Classification ⁷ : A61B 3/13, 3/12</p>	<p>A1</p>	<p>(11) International Publication Number: WO 00/30527</p> <p>(43) International Publication Date: 2 June 2000 (02.06.00)</p>
<p>(21) International Application Number: PCT/US99/27857</p> <p>(22) International Filing Date: 23 November 1999 (23.11.99)</p> <p>(30) Priority Data: 09/198,545 24 November 1998 (24.11.98) US Ref: 281-300 (CIP) 22 November 1999 (22.11.99) US</p> <p>(71) Applicant: WELCH ALLYN, INC. [US/US]; 4341 State Street Road, Skaneateles Falls, NY 13153 (US).</p> <p>(72) Inventors: GOLDFAIN, Ervin; 4422 Cleveland Road, Syracuse, NY 13215 (US). LAGERWAY, William; 6735 Mandy Rue, Auburn, NY 13021 (US). ROBERTS, Chris, R.; 740 Sheldon Road, Skaneateles, NY 13152 (US). SLAWSON, Steven, R.; 405 Oakridge Drive, Camillus, NY 13031 (US). KRAUTER, Allan, I.; 2224 West Lake Road, Skaneateles, NY 13152 (US).</p> <p>(74) Agents: BLASIAK, George, S. et al.; Wall Marjama Bilinski & Burr, Suite 400, 101 South Salina Street, Syracuse, NY 13202 (US).</p>		<p>(81) Designated States: AE, AL, AM, AT, AU, AZ, BA, BB, BG, BR, BY, CA, CH, CN, CU, CZ, DE, DK, EE, ES, FI, GB, GD, GE, GH, GM, HR, HU, ID, IL, IN, IS, JP, KE, KG, KP, KR, KZ, LC, LK, LR, LS, LT, LU, LV, MD, MG, MK, MN, MW, MX, NO, NZ, PL, PT, RO, RU, SD, SE, SG, SI, SK, SL, TJ, TM, TR, TT, UA, UG, UZ, VN, YU, ZA, ZW, ARIPO patent (GH, GM, KE, LS, MW, SD, SL, SZ, TZ, UG, ZW), Eurasian patent (AM, AZ, BY, KG, KZ, MD, RU, TJ, TM), European patent (AT, BE, CH, CY, DE, DK, ES, FI, FR, GB, GR, IE, IT, LU, MC, NL, PT, SE), OAPI patent (BF, BJ, CF, CG, CI, CM, GA, GN, GW, ML, MR, NE, SN, TD, TG).</p> <p>Published <i>With international search report. Before the expiration of the time limit for amending the claims and to be republished in the event of the receipt of amendments.</i></p>
<p>(54) Title: EYE VIEWING DEVICE FOR RETINAL VIEWING THROUGH UNDILATED PUPIL</p>		
<p>(57) Abstract</p> <p>The invention is a low cost, low input power eye viewing device well suited for viewing wide field retinal images through an undilated pupil. Included in the device are a converging light illumination system and an aperture stop. The converging light illumination system provides ease of entry of light rays into an eye, wide field retinal illumination, reduced glare and reduced power consumption. The aperture stop blocks unwanted received glare light not forming part of the retinal image. The device is made especially well suited for retinal viewing through an undilated pupil if the aperture is sized in accordance with the diameter of an undilated pupil.</p>		

FOR THE PURPOSES OF INFORMATION ONLY

Codes used to identify States party to the PCT on the front pages of pamphlets publishing international applications under the PCT.

AL	Albania	ES	Spain	LS	Lesotho	SI	Slovenia
AM	Armenia	FI	Finland	LT	Lithuania	SK	Slovakia
AT	Austria	FR	France	LU	Luxembourg	SN	Senegal
AU	Australia	GA	Gabon	LV	Latvia	SZ	Swaziland
AZ	Azerbaijan	GB	United Kingdom	MC	Monaco	TD	Chad
BA	Bosnia and Herzegovina	GE	Georgia	MD	Republic of Moldova	TG	Togo
BB	Barbados	GH	Ghana	MG	Madagascar	TJ	Tajikistan
BE	Belgium	GN	Guinea	MK	The former Yugoslav Republic of Macedonia	TM	Turkmenistan
BF	Burkina Faso	GR	Greece	ML	Mali	TR	Turkey
BG	Bulgaria	HU	Hungary	MN	Mongolia	TT	Trinidad and Tobago
BJ	Benin	IE	Ireland	MR	Mauritania	UA	Ukraine
BR	Brazil	IL	Israel	MW	Malawi	UG	Uganda
BY	Belarus	IS	Iceland	MX	Mexico	US	United States of America
CA	Canada	IT	Italy	NE	Niger	UZ	Uzbekistan
CF	Central African Republic	JP	Japan	NL	Netherlands	VN	Viet Nam
CG	Congo	KE	Kenya	NO	Norway	YU	Yugoslavia
CH	Switzerland	KG	Kyrgyzstan	NZ	New Zealand	ZW	Zimbabwe
CI	Côte d'Ivoire	KP	Democratic People's Republic of Korea	PL	Poland		
CM	Cameroon	KR	Republic of Korea	PT	Portugal		
CN	China	KZ	Kazakstan	RO	Romania		
CU	Cuba	LC	Saint Lucia	RU	Russian Federation		
CZ	Czech Republic	LI	Liechtenstein	SD	Sudan		
DE	Germany	LK	Sri Lanka	SE	Sweden		
DK	Denmark	LR	Liberia	SG	Singapore		
EE	Estonia						

**EYE VIEWING DEVICE FOR RETINAL
VIEWING THROUGH UNDILATED PUPIL**

Background of the Invention

1. Field of the Invention

This invention relates generally to medical diagnostic
5 instruments, and specifically to an eye viewing device for use
in retinal viewing.

2. Background of the Prior Art

Commercially available eye viewing devices for use in
10 retinal viewing have been observed to exhibit numerous
limitations.

According to an indirect ophthalmoscope design, a beam
splitter is provided in the optical viewing path which directs
illumination light rays into an eye, and simultaneously allows
15 receive imaging light rays to pass therethrough. The
substantial light losses inherent with this design require
that a large, high powered light source be incorporated in the
device for the device to satisfactorily illuminate a retina.
High powered light sources, in general, are difficult to
20 package, consume excessive amounts of electrical input power,
and produce large amounts of heat and unwanted light such as
glare. High powered light sources also have large filaments,

typically larger than the diameter of an undilated pupil. This makes indirect ophthalmoscopes especially susceptible to glare problems attributable to incident light rays being reflected from outer eye structures such as the iris, cornea
5 and sclera.

Cameras for use in retinal viewing, such as fundus cameras, provide high quality imaging. However, retinal viewing cameras, in general, are expensive, typically require pupil dilation for retinal viewing, and typically require
10 operation by a highly skilled and trained camera operator.

There is a need for a compact, lower input power eye viewing device which provides appropriate retinal illumination and which facilitates wide field retinal viewing without requiring pupil dilation.

15

Summary of the Invention

According to its major aspects and broadly stated, the present invention is a low input power, low cost eye viewing device for use in viewing a retina. The device provides wide
20 field retinal viewing without pupil dilation.

In one aspect, an eye viewing device according to the invention includes a converging light illumination system adapted to generate light rays which, when the device is in an

operative position, converge at about a pupil of a patient and diverge inside an eye to illuminate a wide retinal field. The converging light illumination system provides illumination of a wide retinal field through a small pupil which may be in an undilated state. The converging light illumination system also reduces electrical input power consumption and reduces glare, as substantially all light delivered by the illumination system enters an eye through a patient's pupil without being reflected from an eye structure outside of a pupil opening such as the iris and sclera.

In another aspect, an eye viewing device of the invention includes a viewing system having an aperture stop positioned substantially conjugate to a patient's pupil and substantially coaxial with an imaging axis of the viewing system. An aperture stop positioned substantially conjugate to a patient's pupil and substantially coaxial with an imaging axis operates to admit light that forms a retinal image and to block light that does not form the retinal image. The aperture stop operates to block unwanted light both when the device is positioned forward of an operative position and when the device is in an operative position. The aperture stop thereby reduces glare and improves image quality both during entry of the device into an eye (when the device is being

maneuvered into an operative position) and during retinal viewing (when the device is in an operative position).

The eye viewing device is made especially well suited for retinal viewing through an undilated eye by sizing the aperture of the aperture stop in accordance with the diameter of a pupil of an undilated eye. By sizing the aperture in accordance with the diameter of an undilated pupil, the aperture stop operates to block substantially all light reflected from eye structures outside the diameter of a pupil (such as the iris and sclera).

These and other features of the invention will become clear to those skilled in the art from a careful reading of the Detailed Description of the Preferred Embodiments in connection with the referenced drawings.

Brief Description of the Drawings

The preferred embodiment of the invention will now be described by way of example only, with reference to the accompanying figures wherein the elements bear like reference numerals, and wherein:

Fig. 1A is a functional schematic diagram of an eye viewing device of the invention showing illumination light rays for illustrating operation of an illumination system according to the invention;

Fig. 1B is a functional schematic diagram of an eye viewing device of the invention showing receive optical light rays which illustrate operation of the devices' imaging system;

5 Fig. 1C is a functional schematic diagram of an eye viewing device of the invention showing incident illumination light rays when the device is at a distance away from an operative position;

10 Fig. 1D is a functional schematic diagram of the eye viewing device of Fig. 1C showing receive optical light rays when the device is at a distance away from an operative position;

15 Fig. 1E is a functional diagram of an eye viewing device of the invention showing incident light rays reflected from an objective lens;

Fig. 2 is a functional schematic diagram showing incident light rays of an illumination system which may be incorporated in the invention;

20 Fig. 3A is a functional schematic diagram of an embodiment of the invention showing light rays from an on-axis object illustrating operation of an embodiment of an imaging system according to the invention having a defocused mirror;

Fig. 3B is a functional schematic diagram of an embodiment of the invention showing light rays from an off-axis object illustrating operation of an imaging system according to the invention having a defocused mirror;

5 Fig. 3C is a functional schematic diagram of an embodiment of the invention showing illumination light rays which illustrate operation of an illumination system having an on-axis light source;

Fig. 4 is a functional schematic diagram of another
10 embodiment of the invention having a defocused light source;

Fig. 5 is functional schematic diagram of the invention configured for binocular viewing;

Fig. 6 is a physical schematic diagram illustrating various features which may be incorporated in a physical
15 embodiment of the invention.

Detailed Description of the Invention

An exemplary embodiment of an eye viewing device according to the invention is described with reference to
20 Figs. 1A-1E. Eye viewing device 10 includes an illumination system, the operation of which is described mainly with reference to Fig. 1A, and an imaging system, the operation of which is described mainly with reference to Fig. 1B.

The device of Figs 1A-1E is especially well suited for use in viewing a retina through an undilated pupil. Small diameter undilated pupils present numerous challenges to viewing retinal images. Small diameter undilated pupils tend to inhibit the transmission of both incident light directed toward a retina and reflected light corresponding to a retinal image. Furthermore, light that is directed into a pupil and that is blocked from entry into a pupil by highly reflective surfaces of outer eye structures such as the iris and sclera tends to be reflected into a viewing system as glare. As will be explained herein below, the device of Figs. 1A through 1E includes features which operate in combination to overcome the numerous challenges to viewing a retinal image through an undilated pupil. In one aspect, the device of Figs. 1A through 1E includes the combination of a converging light source illumination system and an aperture stop. The converging light source illumination system operates to direct a substantial amount of light through a small diameter opening while the aperture stop operates to block glare attributable to light rays being reflected from outer eye structures.

As best seen by Fig. 1A, the illumination system operates to generate illumination light rays which converge at an apex and diverge thereafter. An eye viewing device having a

converging light ray illumination system is positioned in an operative position relative to a patient when substantially a maximum amount of incident light enters eye 11 through pupil 12. In the device of Fig. 1A-1E, an operative position is achieved when apex 34 of the cone of light generated by the illumination system is positioned at about a pupil 12 of a patient. With a converging light ray illumination system, a substantial amount of illumination light enters a small diametered pupil and at the same time illuminates a wide retinal field. A converging light ray illumination system can be provided by the combination of a light source 14 and objective lens 16 positioned forward of the light source 14 for converging light rays emanating from source 14. With a converging light source illumination system, a much higher percentage of incident light rays enter pupil 12 to illuminate retina 19 than are reflected off outer eye structures 17 and 21. Because there is little wasted incident light, a converging light ray illumination system reduces the electrical input power consumption of the illumination system. Because a relatively smaller amount of incident light reflects off outer eye structures such as iris 17 and sclera 21, there is less unwanted light received by the imaging system.

Light source 14 can be a light generating light source, such as a filament-based lamp, an arc lamp, a fiber optic light source or a solid state light source. However, with presently available technology, light generating light sources are sufficiently large that they introduce packaging problems. Therefore, a preferred light source for the eye viewing device is the light source described with reference to Fig. 2. In the embodiment of Fig. 2, light source 14 is provided by a reflective element such as a mirror, which operates in association with a light-generating light source 18, such as a lamp, and a condenser lens 20 which converges light from light source 18 onto mirror 14.

Aspects of the imaging system of the device will now be described with reference mainly to Fig. 1B. The imaging system of the device includes objective lens 16, imaging lens 22, and an eyepiece lens 24. A retinal image focal plane 26 is produced intermediate objective lens 16 and imaging lens 22, while an eyepiece focal plane 28 is produced intermediate imaging lens 22 and eyepiece lens 24. The imaging system further includes an imaging axis 30 on which lenses 16, 22, and 24 are substantially centered. In all references herein, the term "lens" can refer to a single optical element or a plurality of optical elements functioning together, while an

operative position has been defined herein as the position at which substantially a maximum amount of incident light rays enter eye 11 through pupil 12. An operative position can also be defined as the position at which a patient's pupil is conjugate to aperture stop 32.

The retinal image light rays crossing retinal focal plane 26 consist of light rays that enter eye 11 through pupil 12 and which are reflected from retina 19 through pupil 12. Since small undilated pupils tend to inhibit the transmission of both incident light into an eye and reflected retinal image light out of the eye, retinal images viewed through undilated pupils are readily obscured by glare (which is especially prevalent when retinas are viewed through undilated pupils since incident light is more likely to be reflected from highly reflective outer eye structures). In addition to glare attributable to light being reflected from outer eye structures, retinal images can be obscured by glare attributable to other sources such as light that is reflected from a patient's cornea (corneal glare) and light that is reflected from a component of the eye viewing device such as a lens of the device (internal glare).

To the end that the device is well adapted for viewing retinal images through an undilated pupil, device 10

preferably includes features which operate to reduce such glare, and in so doing reduce the percentage of received light rays not corresponding to a retinal image relative to the percentage of received light rays corresponding to a retinal
5 image.

One feature which operates to reduce the percentage of light rays not corresponding to the retinal image is the feature of converging light illumination, described above. In a converging light illumination system, a relatively high
10 percentage of light enters eye 11 through pupil 12, and a relatively low percentage of light is reflected from outer eye structures 17 and 21 as seen in Fig. 1A. Other features which may be incorporated to increase the percentage of retinal image forming received light relative to unwanted light are
15 described hereinbelow.

In the device of Fig. 1B, an aperture stop 32 is positioned forward of imaging lens 22 to block unwanted light. Aperture stop 32 should be positioned substantially coaxially with imaging axis 30 and substantially conjugate to a
20 patient's pupil 12 when in an operative position in relation to device 10. Positioning of aperture stop 32 substantially coaxial with imaging axis 30 encourages substantially a maximum amount of useful receive imaging light to be admitted

through imaging lens 22 without also admitting glare light that originates radially outside the patient's pupil 12. By positioning aperture stop 32 so that it is substantially conjugate to a pupil, aperture stop 32 operates to block light 5 reflected from outer eye structures 17 and 21. Because the apex 34 of the cone of light generated by illumination system is substantially conjugate to a patient's pupil for positioning the device in an operative position, and because the preferred position of aperture stop is also one that is 10 conjugate to the pupil, then the preferred position of aperture stop 32 in a device made in accordance with Figs.1A-1E can be described as one that is substantially conjugate to the apex of the cone of light generated by the illumination system.

15 For optimal blocking of unwanted received light, aperture 33 of aperture stop 32 should be sized in accordance with the diameter of the pupil through which a retina is viewed. The diameter of an undilated pupil is about 2mm. Accordingly, for optimally configuring device 10 for viewing a retina through 20 an undilated pupil, aperture 33 should be sized to correspond to a patient pupil diameter of about 2mm. The resulting diameter of aperture 33 is determined by multiplying the pupil diameter by the magnification of the pupil in the plane of the

aperture stop 32. This same principle can be applied to optimize the instrument design for other pupil sizes, larger and smaller.

In addition to reducing glare and improving image quality when device 10 is in an operative position, aperture stop 32 reduces glare and improves image quality prior to the device being moved into an operative position. Figs. 1C and 1D illustrate illumination light rays exiting the device and reflecting off the eye as they are received in a viewing system of device 10 during entry of the device into an eye (during the process of moving the device into an operative position). Fig. 1C illustrates incident light rays generated by device 10 when the device is at a distance away from an operative position, while Fig. 1D illustrates received reflected light rays of a device positioned at the same distance away from an operative position as is shown in Fig. 1C. It is seen that when the device is away from an operative position, then light rays generated by the illumination system strike eye 11 in a diverged state (apex 34 of the cone of light is positioned forward of pupil 12). Thus, a relatively small percentage of incident rays enter an eye through pupil 12 and a relatively high percentage light rays are reflected from the highly reflective outer surfaces of eye structures

such as iris 17 and sclera 21. Light rays reflected from outer eye structures 17 and 21 tend to be reflected at an angle with respect to imaging axis 30. The curved surface of eye 11 assures that reflected light rays are reflected at an angle with respect to axis 30. When device 10 is a substantial distance away from an operative position many light rays reflected from eye 11 during entry of the device are reflected out of the viewing system entirely as is indicated by rays 36'. The majority of light rays that are received in the viewing system are blocked by aperture stop 32 as is indicated by rays 36. Only a small percentage of light rays such as rays 37 pass through aperture 33. Light rays that pass through aperture 33 consist of rays that originated as incident light rays directed substantially along axis 30 and that passed through pupil 12 to retina 19. Thus, during entry of device 10 into eye 11, it can be seen that aperture stop 32 tends to block unwanted light and to pass light corresponding to a retinal image.

It will be seen that without aperture stop 32, a substantial majority of light rays transmitted to eyepiece focal plane 28 during entry would be light rays reflected from outer eye structures 17 and 21. Thus, the image received at eyepiece focal plane 28 would be heavily obscured by glare.

With aperture stop 32 the substantial majority of light rays received at eyepiece focal plane correspond to retina 19.

During entry into the eye, the user will see a small field image of the retina, known as the "red reflex" which helps an

5 operator move the device into an operative position without significant glare. By maintaining the retinal image spot near the center of eyepiece focal plane 28 and moving the device toward an eye 11, an operative position can easily be achieved.

10 Additional glare or unwanted light reducing features may be incorporated in the device. As is shown in Figs. 1A-1E, light source 14 may be positioned just forward of aperture stop 32 outside of the boundary between received and blocked light and off-axis with respect to imaging axis 30 of device
15 10. Positioning light source forward of aperture stop 32, outside of the boundary between received and blocked light defined by aperture 33, assures that light source 14 has no obscuring effect on the viewed image and assures maximum image brightness in the user's eye. Positioning light source 14
20 off-axis also reduces both internal and corneal glare. By positioning light source off-axis, incident light that is reflected off of lens 16 or off of cornea 15 is directed at an

angle with respect to axis 30 and, therefore, away from the optical receive path.

Glare may be further reduced by shaping the first surface 23 of objective lens 16 so that first surface 23 is curved and substantially concentric with the center of aperture 33 as seen by the embodiment of Fig. 1E. This assures that light that is reflected from surface 23 is reflected to a point equal to and opposite light source 14 with respect to imaging axis 30. If light source 14 is positioned outside of the boundary dividing blocked and received light defined by aperture 33, the concentric curved first surface 23 assures that internal glare resulting from light being reflected from surface 23 is blocked by aperture stop 32.

In addition to the above features reducing unwanted received light, glare can be reduced by disposing linear polarizers in the imaging and illumination paths in a crossed configuration.

An alternative embodiment of the invention is described with reference to Figs. 3A-3C. In the embodiment shown in Figs. 3A-3C, light source 14 is disposed directly in the field of view in a highly defocused position in relation to focal planes 26 and 28. By disposing light source 14 on imaging axis 30, light source 14 provides for maximally efficient

illumination of a retina 19. Positioning the light source off-axis as is shown by light source 14' results in less-than-maximally efficient retinal illumination, but also reduces glare for reasons that have been discussed herein.

5 Light source 14 in the embodiment of Fig. 3A-3C should be positioned in a highly defocused position in relation to any image plane of the eye viewing device conjugate to a patient's retina 19 in an operative position in relation to device 10. As shown in the imaging system diagrams of Fig. 3A-3C, a
10 highly defocused position for source 14 in relation to an image focal plane conjugate to a retina is provided by disposing source 14 intermediate retinal focal plane 26 and imaging lens 22. In general, source 14 becomes less in focus at any plane conjugate to and including eyepiece focal plane
15 28 as the source is moved toward imaging lens 22 and away from retinal focal plane 26. Preferably, source 14 is positioned as close as is physically possible to lens 22.

 Corneal glare can be reduced in the embodiment of Figs. 3A-3C if source 14 is disposed in device 10 in a position that
20 is conjugate to the surface of a cornea when the device is in an operative position in relation to a patient. If light source 14 is positioned conjugate to cornea 15, many light rays which do happen to be reflected from cornea 15 are imaged

directly onto light source 14. If light source 14 is provided by a reflective element as shown, these light rays correspond to a cornea image and are blocked before reaching eyepiece focal plane 28, thereby reducing corneal glare.

5 In a specific example of an eye viewing device designed according to the general configuration described with reference to Figs. 1A-1E and 3A-3C, the objective lens 16 may be provided by a lens system having a focal length of about 25mm, and a back focal length of about one-half the focal
10 length. The eye viewing device may be configured so that the lens surface closest to the patient in the objective lens system is positioned about 25mm from a patient's cornea when in an operative position. The objective lens system accepts parallel or nearly parallel light from a patient's eye and
15 focuses the light to an internal image located at or near the back focal plane 26 of the objective. The objective lens system may have a diameter of about 25mm. Imaging lens 22, meanwhile, may be provided by a lens system having a focal length of about 25mm, a back focal length of about 18mm and a
20 clear aperture of about 20mm. The imaging lens may project an internal image from the objective focal plane 26 to eyepiece focal plane 28 at a magnification of about 0.6X. Eyepiece focal plane 28 may have an aperture of about 8mm in diameter,

corresponding to the focal plane diameter of a typical 20X eyepiece. The axial length from objective lens 16 to eyepiece focal plane 28 may be about 160mm. In the illumination system described with reference to Fig. 3C, condenser lens 20 may be
5 provided by a condenser system having a numerical aperture of about 0.2 to 0.4, working at a magnification of about 1X to 2X, with a focal length of about 9mm. In the embodiment of Figs. 1A-1E, aperture stop 32 may be positioned substantially normal to axis 30 and approximately halfway between the most
10 rearward point of light source 14 and the most forward point of imaging lens 22. Aperture stop 32 may have an aperture diameter of about 4.6mm.

An alternative optical configuration for the eye viewing device of Figs. 3A-3C having a defocused light source is
15 described with reference to Fig. 4. In the eye viewing device of Fig. 4, light source 14 is disposed forward of objective lens 16 and imaging lens 22 is deleted. Light source 14 is disposed in a highly defocused position in relation to retinal focal plane 26 by disposing light source 14 in proximity with
20 objective lens 16. In the embodiment of Fig. 4, objective lens 16 does not form part of the optical illumination system. Instead, illumination light rays which converge at a cornea 15 and diverge toward a retina 19 are formed by disposing

condenser lens 20 in relationship with light source mirror 14 such that light rays reflected from the mirror converge after being reflected. Further with reference to the embodiment of Fig. 4, eyepiece lens 24 may optionally be removed and
5 replaced with image sensor 52, such as a CCD image sensor, which is positioned on retinal focal plane 26. A processor system (not shown) in communication with sensor 52, can be configured to capture image signals generated by sensor 52, process such signals, and if desirable, electronically reverse
10 or magnify any captured images to accomplish the function provided optically by imaging lens 22 of the eye viewing device of Figs 1A-3C.

The conventional lenses in the systems described hereinabove can be replaced with similarly functioning optical
15 elements such as diffractive lenses, binary gratings, phase filters, holographic optical elements (HOE), gradient-index lenses, and hybrid optical elements.

The invention can be adapted to provide binocular viewing as is illustrated by the embodiments of Fig. 5. As seen in
20 Fig. 5, a binocular eye viewing device according to the invention typically includes a collimating optical element 70 for collimating light rays of the imaging path, and separating optics 72 for splitting light rays transmitted by collimating

optics 70 into two separate imaging paths 74A and 74B.

Separating optics 72 typically include a combination of such optical elements as prisms and/or mirrors. Continuing with reference to Fig. 5, binocular eye viewing device 10" may

5 further include orientation optics 76 disposed in each binocular imaging path 74A, 74B for setting the orientation of images transmitted by separating optics as is necessary.

Orientation optics 76 may include such optical elements as prism and/or mirror optical elements. Binocular eye viewing

10 device 10" may further include decollimation optics 78 and eyepiece optics 80 disposed in each imaging path 74A and 74B.

Each eyepiece optics 80 collimates light so that images can be perceived by a viewer. The eye tubes (not shown) of eyepiece

optics 80 may be arranged in an orientation slightly diverging
15 toward a viewer's eyes to approximate the direct viewing condition of a target by a pair of eyes.

Several functional aspects of the invention have been described. Certain additional features which may be incorporated in physical embodiments of the invention will now
20 be described in detail.

Shown in Fig. 6 is a physical schematic diagram of an embodiment of the invention which can be reconfigured for optimizing various functional aspects of the eye viewing

device. In the embodiment of Fig. 6, housing 44 of eye viewing device 10 includes lens holders 60, 61, 62 and 66 and replaceable lens modules 40, 41, 42 and 46 replaceably received in their respective holders. As will be explained
5 hereinbelow, replacing a certain lens module or a grouping of lens modules changes functional aspects of the eye viewing device enabling the ophthalmoscope to be optimized for a specific intended use.

For example, with reference to Figs. 1A-1E, and 3A-3C, it
10 is seen that the area of retina 19 that is illuminated by the illumination system depends on the diameter and optical power of objective lens 16 and on the magnification selected for the lens at the operative position of the eye viewing device. This area corresponds to the angle α as shown in Figs. 1A and
15 3C. The field of view of the imaging system, meanwhile, also depends on the diameter and optical power of objective lens 16 and on the magnification of the lens at the operative position of the eye viewing device.

It is desirable that eye viewing device 10 images a wide
20 field of view. While a wide field of view and illumination angle, α , are highly desirable for an accurate and efficient diagnosis of various problems, a smaller field of view and illumination angle are desirable for ease of use. As the

angle of illumination, α , becomes less steep, illumination light rays are more easily directed into an eye through a pupil, so that entry into an eye is easier. This is because as the illumination angle, α , becomes less steep, light rays from source 14 can be directed through pupil 12 over a greater range of cornea-to-lens distances. Accordingly, in view of the above, it would be beneficial to provide an eye viewing device which could be configured either for optimized field of view or optimized ease of use.

10 In a preferred embodiment, the imaging system of device 10 images a field that contains the area of a retina that is illuminated by the illumination system. Most preferably the area of the retina that is imaged by the imaging system is about 15 percent to 30 percent larger than the area that is 15 illuminated. This feature provides improved orientation of a viewed field and reduces alignment considerations between illumination and viewing.

A possible embodiment of reconfigurable eye viewing device according to the invention is described with reference 20 to the physical schematic diagram of Fig. 6. This particular physical layout diagram includes first and second lens modules 40 and 41. First lens module 40 includes objective lens 16, while second lens module 41 includes imaging lens 22. While

the field of view and illumination angle depend mainly on the sizing, optical power, and magnification selected for objective lens 16, imaging lens 22 will normally be replaced along with lens 16, since the sizing and optical power of lens 16 are coordinated with those of lens 22. The housing 44 and lens modules 40, 41 are complementarily designed so that the modular lens modules can be manually removed and replaced from housing 44 while maintaining a common eyepiece focal plane 28. In a reconfigurable eye viewing device, a first set of lens modules can be provided to configure the eye viewing device for imaging a wide field of view, while a second set of modules can provide a reduced field of view (but with increased magnification), making the instrument easier to maneuver into an operative position. Such a device can be made easier to use simply by replacing the first set of lens modules with the second set of lens modules.

To complement the change in field of view accomplished by changing the first and second lens modules, the illumination condenser system may also be changed in a modular fashion to optimize the illumination characteristics to suit the user's needs. In all condenser systems with a given condenser size, the ability to collect the light from a light generating light source is balanced with the angle at which the light can be

transmitted and the magnification at which the image of the light generating light source is projected. The lenses inside the illumination lens module 42 can be selected such that the illumination system matches the illumination numerical aperture of the given objective module 40.

In a further alternate embodiment, the invention can be adapted to capture electronic images representing an imaged retina. One such embodiment is described with reference to Fig. 6. In Fig. 6, an eye viewing device 10 is shown that can be reconfigured for electronic image capture. Fig. 6 shows an eye viewing device adapted so that eyepiece module 46 can be replaced with a video module 50. It is seen that eye viewing device 10 normally includes an eyepiece module 46 having an eyepiece lens 24 which collimates imaging light rays so that a retinal image can be viewed by a user. Eyepiece 46 can be replaced with video module 50 which includes certain components that configure the eye viewing device for video capture. In particular, a video module 50 may contain an image sensor 52, such as a CCD image sensor, which is in an operative position in relation to the imaging system when the video module is installed in holder 66. The image sensor 52 is in electrical communication with a processor system 54 which may be programmed to control image sensor 52 and to

capture and, possibly to store image data generated by and received from image sensor 52. While processor system 54 is shown as being disposed in video module 50, it is understood that processor system 54 could be disposed external to video module 50. The video module 50 may further be in communication with an external display screen and/or an external processing system via cable 56, for example, so that video images captured by image sensor can be displayed or otherwise output, and possibly archived.

10 Video module 50 can be designed so that image sensor 52 lies on eyepiece focal plane 28 when module 50 is in an operative position in holder 66. It is seen that an eye viewing device of the invention can be configured for video capture by replacing eyepiece module 46 with a video module 50
15 without adding or replacing additional lenses of the imaging system. Alternative sized imagers may also be used, with the addition of image resizing lenses. Such a configuration shifts the location of focal plane 28.

While the present invention has been particularly shown
20 and described with reference to the preferred mode as illustrated in the drawings, it will be understood by one skilled in the art that various changes in detail may be effected therein without departing from the spirit and scope of the invention as defined by the claims.

What is claimed is:

1 1. An eye viewing device for viewing a structure of an eye
2 having a pupil, said device comprising:
3 an illumination system generating a converging cone of light
4 that converges at an apex and diverges thereafter;
5 an imaging system having an imaging axis; and
6 an aperture stop disposed in said device substantially
7 coaxial with said imaging axis and substantially conjugate to
8 said apex whereby corneal glare is reduced.

1 2. The eye viewing device of claim 1, wherein an aperture
2 of said aperture stop is sized to substantially correspond to a
3 size of said pupil.

1 3. The eye viewing device of claim 1, wherein said
2 illumination system includes a light source positioned off-axis
3 with respect to said imaging axis, whereby internal and corneal
4 glare in said device is reduced.

1 4. The eye viewing device of claim 1, wherein said
2 illumination system includes a light source positioned off-axis
3 with respect to said imaging axis, and wherein said imaging

4 system includes an objective lens, said objective lens having a
5 first surface closest to said light sources curved substantially
6 concentric about a center of an aperture of said aperture stop,
7 whereby internal glare in said device is reduced.

1 5. The eye viewing device of claim 1, wherein said
2 illumination system includes a light source positioned off-axis
3 with respect to said imaging axis, and wherein said off-axis
4 positioned light source is positioned outside of an aperture of
5 said aperture stop, whereby said light source has no obscuring
6 effect on images received by said viewing device.

1 6. The eye viewing device of claim 1, wherein said
2 illumination system includes a light source positioned off-axis
3 with respect to said imaging axis wherein said off-axis
4 positioned light source is positioned outside of a border between
5 received and blocked light defined by said aperture stop and
6 wherein said imaging system includes an objective lens having a
7 curved first surface curved concentric about a center of said
8 aperture, whereby said light source has no obscuring effect on
9 images received by said viewing device, and whereby incident
10 light reflected from said first surface is blocked by said
11 aperture stop.

1 7. The device of claim 1 wherein said imaging system
2 comprises binocular optics adapted to provide binocular viewing.

1 8. The device of claim 1, wherein said device includes a
2 housing including at least one lens holder, and a plurality of
3 lenses, at least one of said lenses being packaged in a lens
4 module which is adapted to be received in said at least one lens
5 holder.

1 9. The device of claim 1, wherein said device includes a
2 housing and wherein said device further comprises:

3 an eyepiece holder defined by said housing;

4 an eyepiece having an eyepiece lens, said eyepiece being
5 adapted to be received in said eyepiece holder; and

6 a video module having an image sensor, said video module
7 being adapted to be received in said eyepiece holder wherein said
8 eyepiece holder is adapted to receive only one of said eyepiece
9 or said video module at a given time.

1 10. The device of claim 1, wherein a retinal field of view
2 of said imaging system is larger than a retinal area of
3 illumination of said illumination system.

1 11. The device of claim 1, wherein a retinal field of view
2 of said imaging system is between about 15 to 30 percent larger
3 than a retinal area of illumination of said illumination system.

1 12. An eye viewing device for viewing a structure of an eye
2 having a retina and a pupil, said device comprising:

3 an illumination system for illuminating said retina;

4 an imaging system having an imaging axis;

5 an aperture stop disposed in said device substantially
6 coaxial with said imaging axis and substantially conjugate to
7 said pupil when said device is in an operative position in
8 relation to said eye, whereby corneal glare is reduced.

1 13. The eye viewing device of claim 12, wherein an aperture
2 of said aperture stop is sized to substantially correspond to a
3 size of said pupil.

1 14. The eye viewing device of claim 12, wherein a aperture
2 of said illumination system includes a light source positioned
3 off-axis with respect to said imaging axis, whereby internal and
4 corneal glare in said device is reduced.

1 15. The eye viewing device of claim 12, wherein said
2 illumination system includes a light source positioned off-axis
3 with respect to said imaging axis, and wherein said imaging
4 system includes an objective lens, said objective lens having a
5 first surface closest to said light source curved substantially
6 concentric about a center of an aperture of said aperture stop,
7 whereby internal glare in said device is reduced.

1 16. The eye viewing device of claim 12, wherein said
2 illumination system includes a light source positioned off-axis
3 with respect to said imaging axis, and wherein said off-axis
4 positioned light source is positioned outside of an aperture of
5 said aperture stop, whereby said light source has no obscuring
6 effect on images received by said viewing device.

1 17. The eye viewing device of claim 12, wherein said
2 illumination system includes a light source positioned off-axis
3 with respect to said imaging axis, wherein said off-axis
4 positioned light source is positioned outside of a border between
5 received and blocked light defined by said aperture stop and
6 wherein said imaging system includes an objective lens having a
7 curved first surface curved concentric about a center of said

8 aperture, whereby said light source has no obscuring effect on
9 images received by said viewing device, and whereby incident
10 light reflected from said first surface is blocked by said
11 aperture stop.

1 18. The device of claim 12, wherein said imaging system
2 comprises binocular optics adapted to provide binocular viewing.

1 19. The device of claim 12, wherein said device includes
2 a housing including at least one lens holder, and a plurality of
3 lenses, at least one of said lenses being packaged in a lens
4 module which is adapted to be received in said at least one lens
5 holder.

1 20. The device of claim 12, wherein said device includes
2 a housing and wherein said device further comprises:

3 an eyepiece holder defined by said housing;

4 an eyepiece having an eyepiece lens, said eyepiece being
5 adapted to be received in said eyepiece holder; and

6 a video module having an image sensor, said video module
7 being adapted to be received in said eyepiece holder wherein said
8 eyepiece holder is adapted to receive only one of said eyepiece
9 or said video module at a given time.

10 21. The device of claim 12, wherein a retinal field of view
11 of said imaging system is larger than a retinal area of
12 illumination of said illumination system.

1 22. The device of claim 12, wherein a retinal field of view
2 of said imaging system is between about 15 to 30 percent larger
3 than a retinal area of illumination of said illumination system.

1 23. An eye viewing device for use in viewing a structure
2 of an eye, said eye viewing device comprising:

3 a patient end and a viewing end;

4 an imaging system having an imaging path and at least one
5 retinal image focal plane; and

6 an illumination system including a light source disposed in
7 said imaging path and positioned in a defocused position in
8 relation to said at least one retinal image focal plane wherein
9 said illumination system is adapted to generate illumination
10 light rays that converge substantially at or forward of said
11 patient end, whereby said converged light rays can easily enter
12 a pupil arranged forward of said patient end.

1 24. The eye viewing device of claim 23, wherein said light
2 source comprises a reflective element.

3 25. The eye viewing device of claim 23, wherein said light
4 source comprises a light-generating light source.

1 26. The eye viewing device of claim 25 wherein said light
2 source is provided by a miniature incandescent lamp.

1 27. The eye viewing device of claim 23, wherein said
2 illumination system comprises:

3 a reflective element defining said light source;

4 a light-generating light source directing light toward
5 said reflective element; and

6 a condenser optical element interposed between said
7 light-generating light source and said reflective element,
8 said condenser optical element converging light rays from said
9 light-generating light source onto said reflective element.

1 28. The eye viewing device of claim 27, wherein said
2 light-generating light source is provided by a miniature
3 incandescent lamp.

1 29. The eye viewing device of claim 23, wherein said
2 imaging system includes an objective optical element and an
3 imaging optical element, and wherein said light source is

4 disposed intermediate said objective optical element and said
5 imaging optical element.

1 30. The eye viewing device of claim 29, wherein said
2 light source is disposed in close proximity with said imaging
3 optical element.

1 31. The eye viewing device of claim 29, wherein said eye
2 viewing device includes a housing, and wherein at least one of
3 said objective optical element and said imaging optical
4 element are adapted to be replaceably disposed in said
5 housing.

1 32. The eye viewing device of claim 23, wherein said
2 light source is a light transmitting light source selected
3 from the group consisting of a light pipe, a light guide, a
4 diffractive optical element and a holographic optical element.

1 33. The eye viewing device of claim 23, wherein said
2 imaging system includes an image sensor for generating
3 electrical signals representing said retina.

1 34. The eye viewing device of claim 23, wherein said
2 imaging system includes an imaging axis, and wherein said
3 light source is disposed slightly off said imaging axis.

1 35. The eye viewing device of claim 23, wherein said eye
2 viewing device comprises binocular optics for forming a
3 binocular image of said eye structure.

1 36. The eye viewing device of claim 35, wherein said
2 binocular optics include:

3 collimating optics for collimating light along said
4 imaging path;

5 separating optics for separating light transmitted by
6 said collimating optics along first and second light paths;

7 orientation optics disposed in at least one of said first
8 and second paths for setting an orientation of received
9 images;

10 decollimating optics disposed in at least one of said
11 first and second optical paths for decollimating light
12 transmitted by said adjusting optics; and

13 eyepiece optics disposed in at least one of said first
14 and second paths for recollimating light decollimated by said
15 decollimating optics.

16 37. An eye viewing device comprising:
17 a housing having an eyepiece holder;
18 an eyepiece having an eyepiece lens, said eyepiece being
19 adapted to be received in said eyepiece holder; and
20 a video module having an image sensor, said video module
21 being adapted to be received in said eyepiece holder, wherein
22 said eyepiece holder is adapted to receive only one of said
23 eyepiece or said video module at a given time.

1 38. The eye viewing device of claim 37, further
2 comprising an imaging system including a image focal plane
3 disposed in said housing, and wherein said video module is
4 configured so that said image sensor lies substantially on
5 said image focal plane when said video module is received in
6 said holder.

1 39. The eye viewing device of claim 37, wherein said
2 light source is disposed in a position that is substantially
3 conjugate with a patient's cornea when said device is in an
4 operative position in relation to said eye.

1 40. An eye viewing device for use in viewing a structure
2 of an eye, said device including:

3 a patient end and a viewing end;

4 an imaging system having an imaging path and at least one
5 retinal image focal plane; and

6 an illumination system including a light source disposed
7 in said imaging path and positioned in a defocused position in
8 relation to said retinal image focal plane, said illumination
9 system including an objective lens disposed intermediate said
10 light source and said patient end, said light source
11 positioned beyond said retinal image focal plane in a
12 direction away from said objective lens so that said objective
13 lens operates to converge illumination light rays generated by
14 said light source.

1 41. The eye viewing device of claim 40, wherein said
2 illumination system comprises:

3 a reflective element defining said light source;

4 a light-generating light source directing light toward
5 said reflective element; and

6 a condenser optical element interposed between said
7 light-generating light source and said reflective element,
8 said condenser optical element converging light rays from said
9 light-generating light source onto said reflective element.

1 42. The eye viewing device of claim 40, wherein said
2 imaging system includes an image sensor for generating
3 electrical signals representing said structure.

1 43. The eye viewing device of claim 40, wherein said
2 device comprises binocular optics for forming a binocular
3 image of said eye structure.

1 44. The eye viewing device of claim 40, wherein said
2 light source is disposed in a position that is substantially
3 conjugate with patient's cornea when said device is in an
4 operative position in relation to said eye, so that light rays
5 reflected from said cornea are converged onto said light
6 source.

1 45. An eye viewing device for use in viewing a structure
2 of an eye, said device including:
3 a patient end and a viewing end;
4 an imaging system having an imaging path and at least one
5 retinal image focal plane; and
6 an illumination system including a light source disposed
7 in said imaging path in a position that is defocused in
8 relation to said at least one retinal image focal plane and

9 that is substantially conjugate to a patient cornea when said
10 device is in an operative position in relation to said eye, so
11 that light rays reflected from said cornea are converged onto
12 said light source.

1 46. The eye viewing device of claim 45, wherein said
2 illumination system comprises:
3 a reflective element defining said light source;
4 a light-generating light source directing light toward
5 said reflective element; and
6 a condenser optical element interposed between said
7 light-generating light source and said reflective element,
8 said condenser optical element converging light rays from said
9 light-generating light source onto said reflective element.

1 47. The eye viewing device of claim 45, wherein said
2 imaging system includes an image sensor for generating
3 electrical signals representing said structure.

1 48. The eye viewing device of claim 45, wherein said
2 device comprises binocular optics for forming a binocular
3 image of said eye structure.

1 49. An eye viewing device comprising:
2 a housing;
3 an imaging system;
4 an illumination system;
5 an objective lens holder for receiving an objective lens
6 module;
7 an imaging lens holder for receiving an imaging lens
8 module;
9 a first objective lens module and imaging lens module
10 pair configured to provide wide field viewing; and
11 a second objective lens module and imaging lens module
12 pair configured to provide narrower field viewing and easier
13 entry than said first objective lens module and imaging lens
14 module pair, wherein said objective lens and imaging lens
15 holders are adapted to receive only one of said first or
16 second objective lens and imaging lens modules at a given
17 time.

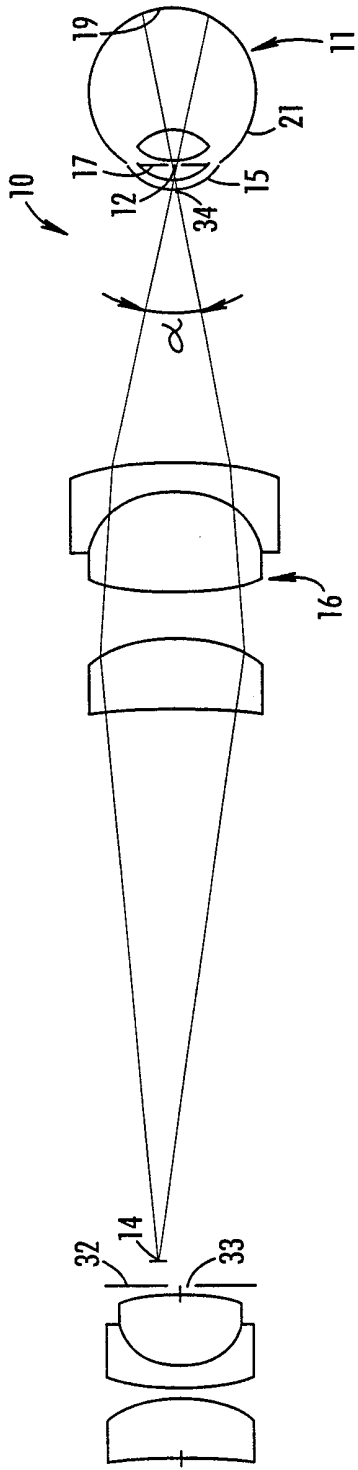

FIG. 1A

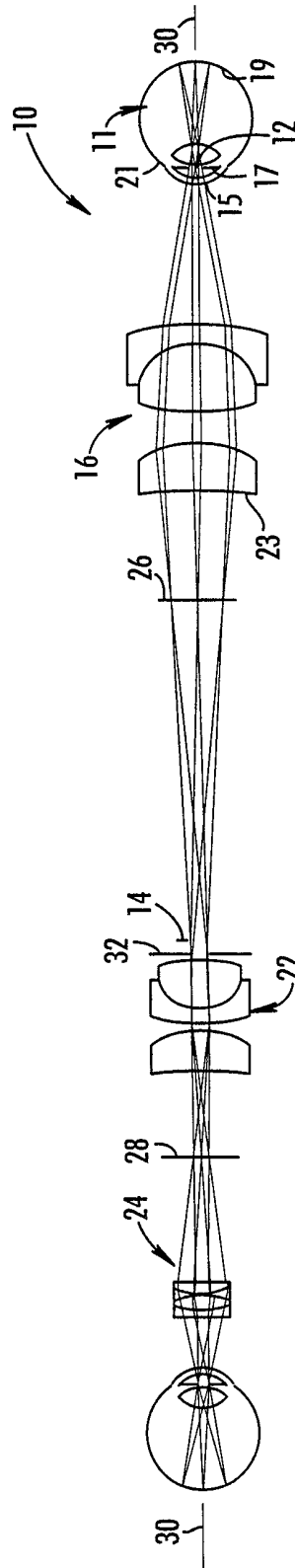

FIG. 1B

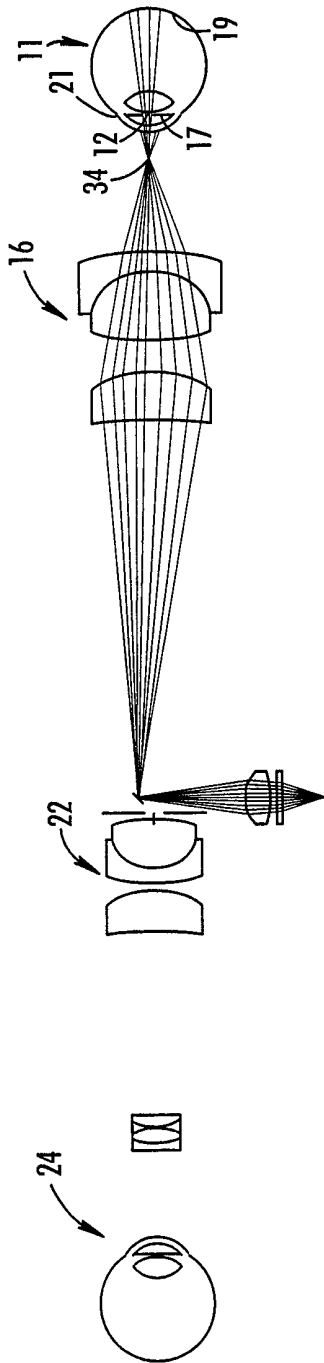

FIG. 1C

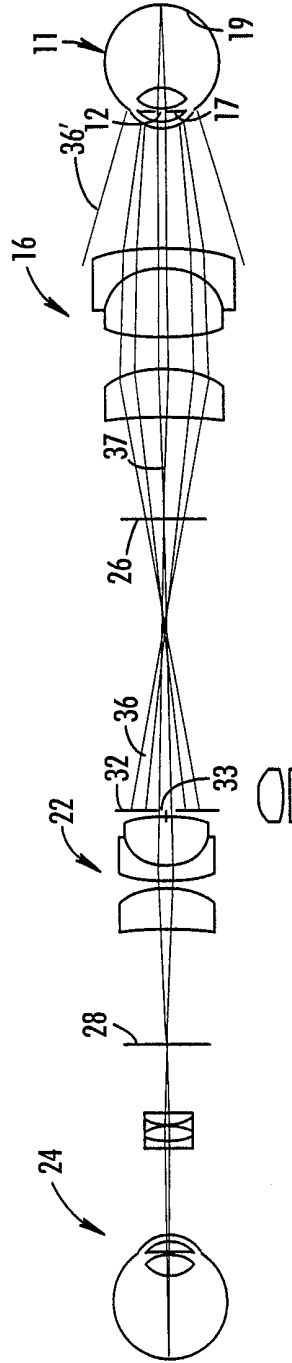

FIG. 1D

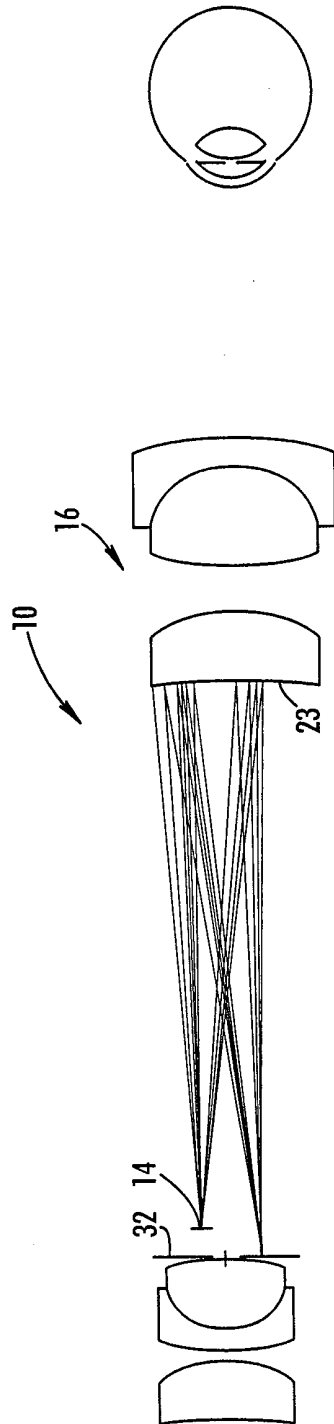

FIG. 1E

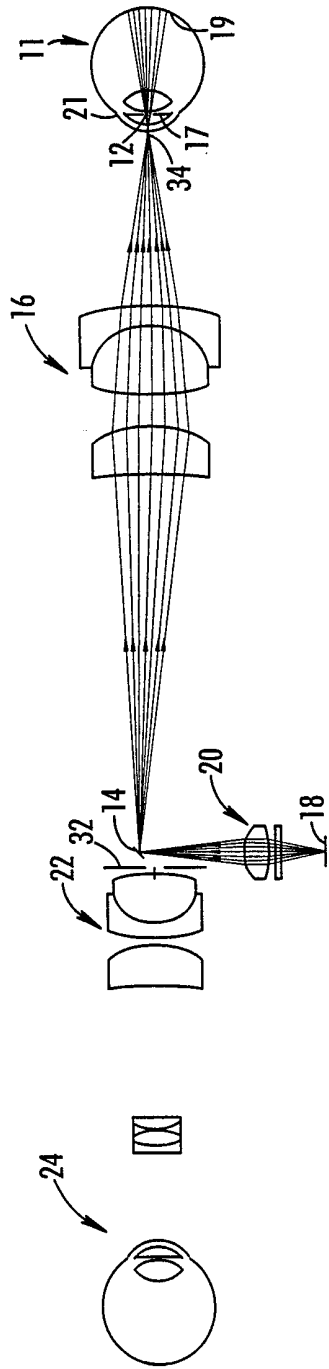

FIG. 2

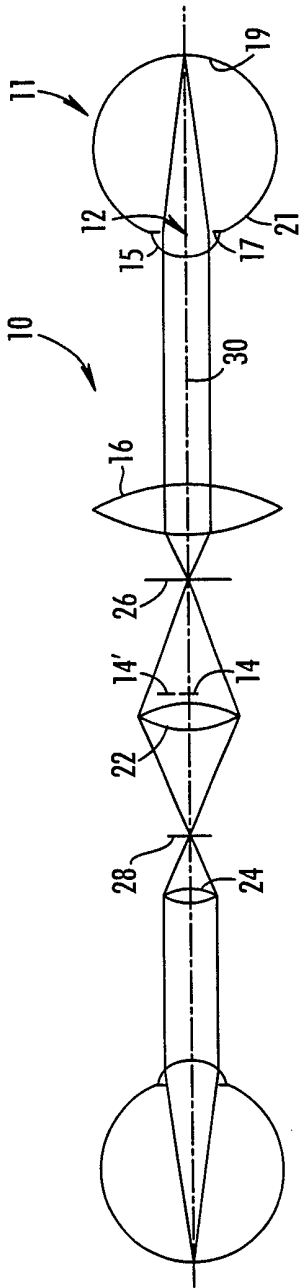

FIG. 3A

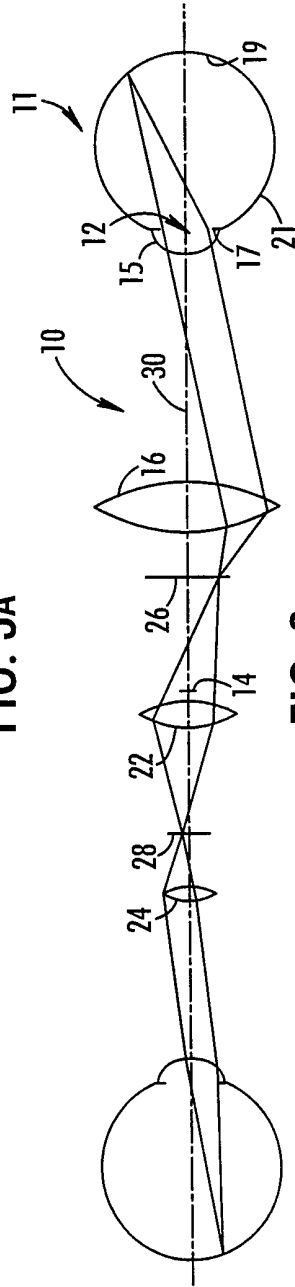

FIG. 3B

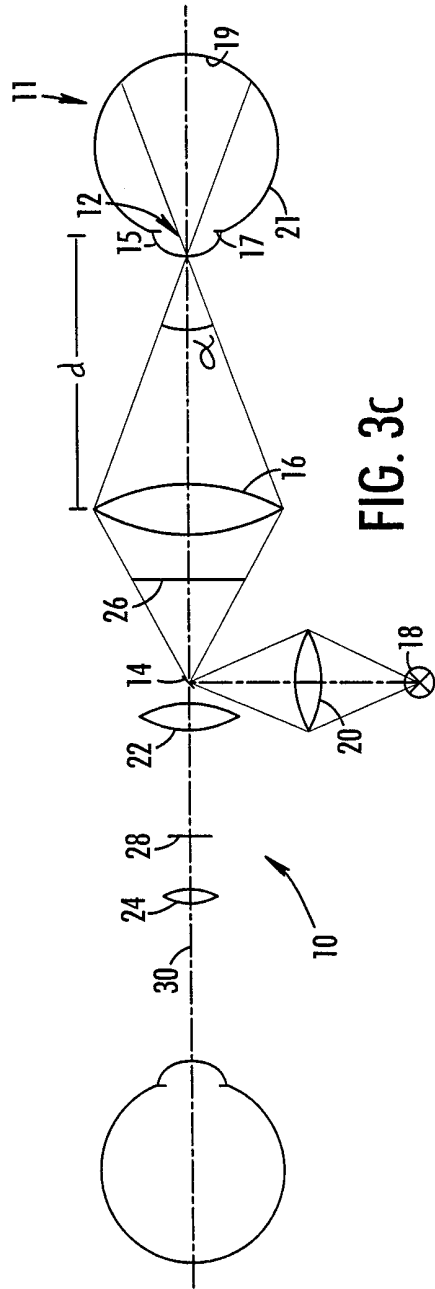

FIG. 3C

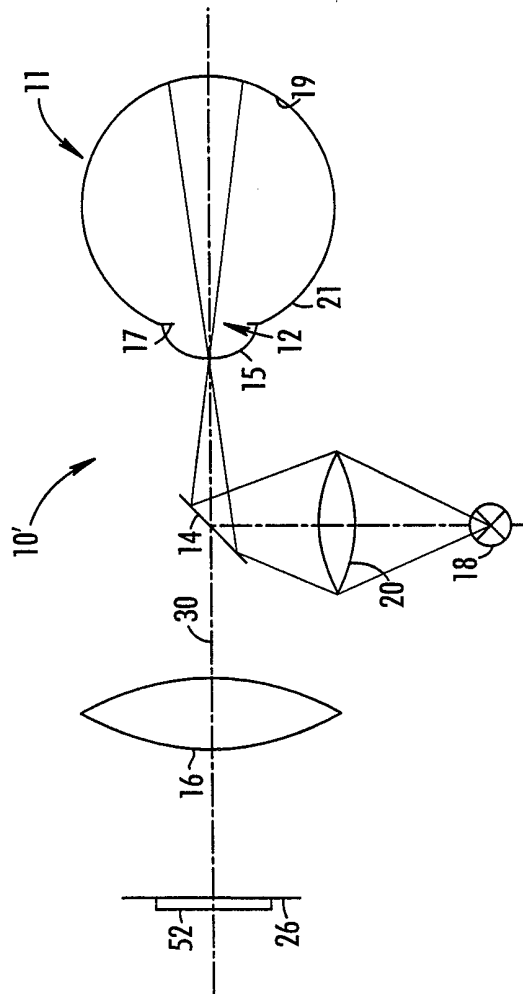

FIG. 4

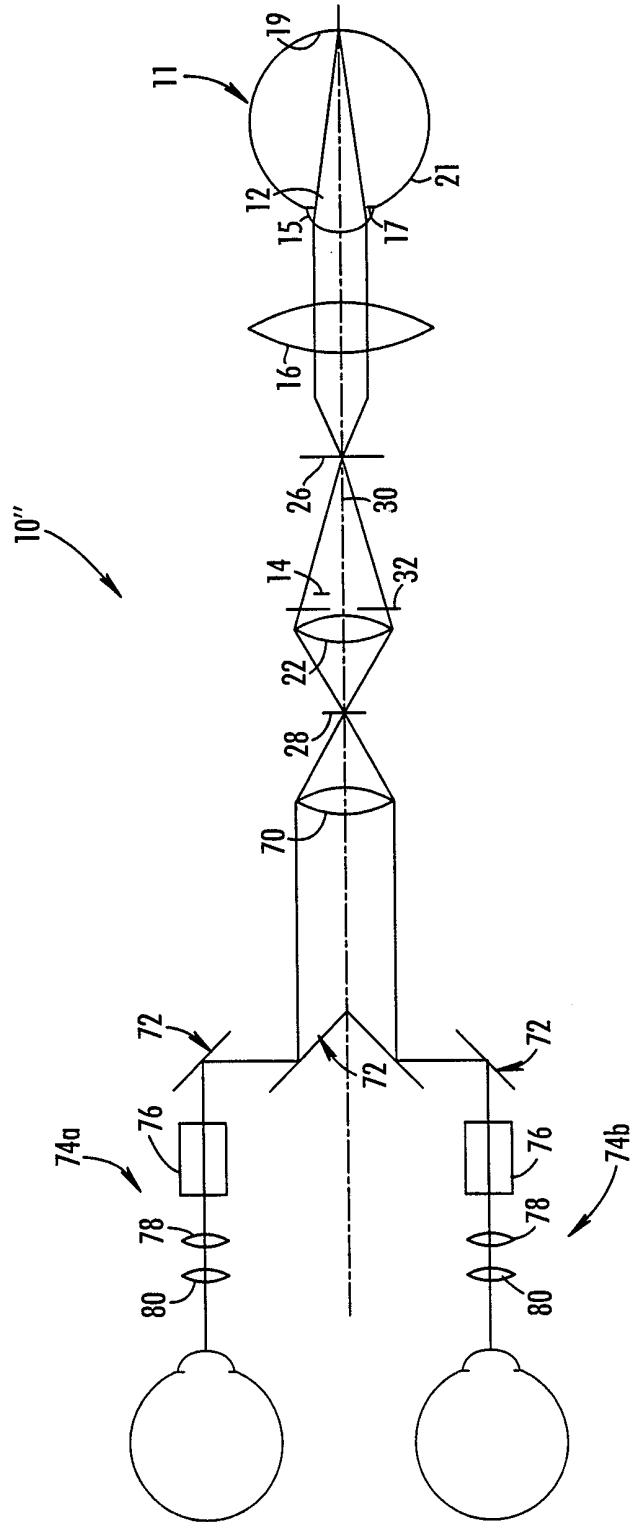

FIG. 5

INTERNATIONAL SEARCH REPORT

International application No PCT/US 99/27857
--

A. CLASSIFICATION OF SUBJECT MATTER
 IPC 7 A61B3/13 A61B3/12

According to International Patent Classification (IPC) or to both national classification and IPC

B. FIELDS SEARCHED

Minimum documentation searched (classification system followed by classification symbols)
 IPC 7 A61B

Documentation searched other than minimum documentation to the extent that such documents are included in the fields searched

Electronic data base consulted during the international search (name of data base and, where practical, search terms used)

C. DOCUMENTS CONSIDERED TO BE RELEVANT

Category °	Citation of document, with indication, where appropriate, of the relevant passages	Relevant to claim No.
X	US 3 586 424 A (SCHENK GEORGE F ET AL) 22 June 1971 (1971-06-22)	1-3,5,6, 10-14, 16,21,22
A	column 5, line 7 -column 7, line 31 the whole document	4,15,17, 23-48
X	---	
X	US 4 721 378 A (VOLK DAVID) 26 January 1988 (1988-01-26) column 2, line 13 -column 4, line 29	1,12
A	---	
A	US 4 682 866 A (VOLK DAVID) 28 July 1987 (1987-07-28) the whole document	7,18,35, 36,43,48
A	---	
A	US 4 856 872 A (SPITZNAS M ET AL) 15 August 1989 (1989-08-15) the whole document	8,19,31, 49

	-/--	

Further documents are listed in the continuation of box C. Patent family members are listed in annex.

° Special categories of cited documents :

<p>*A* document defining the general state of the art which is not considered to be of particular relevance</p> <p>*E* earlier document but published on or after the international filing date</p> <p>*L* document which may throw doubts on priority claim(s) or which is cited to establish the publication date of another citation or other special reason (as specified)</p> <p>*O* document referring to an oral disclosure, use, exhibition or other means</p> <p>*P* document published prior to the international filing date but later than the priority date claimed</p>	<p>*T* later document published after the international filing date or priority date and not in conflict with the application but cited to understand the principle or theory underlying the invention</p> <p>*X* document of particular relevance; the claimed invention cannot be considered novel or cannot be considered to involve an inventive step when the document is taken alone</p> <p>*Y* document of particular relevance; the claimed invention cannot be considered to involve an inventive step when the document is combined with one or more other such documents, such combination being obvious to a person skilled in the art.</p> <p>* & * document member of the same patent family</p>
--	--

Date of the actual completion of the international search 6 April 2000	Date of mailing of the international search report 20.04.00
--	---

Name and mailing address of the ISA European Patent Office, P.B. 5818 Patentlaan 2 NL - 2280 HV Rijswijk Tel. (+31-70) 340-2040, Tx. 31 651 epo nl, Fax: (+31-70) 340-3016	Authorized officer Daintith, N
--	--

INTERNATIONAL SEARCH REPORT

International Application No
PCT/US 99/27857

C.(Continuation) DOCUMENTS CONSIDERED TO BE RELEVANT

Category *	Citation of document, with indication, where appropriate, of the relevant passages	Relevant to claim No.
A	US 4 252 420 A (KOHAYAKAWA YOSHIMI) 24 February 1981 (1981-02-24) figures 1,11 -----	9,20,33, 37,38,42

INTERNATIONAL SEARCH REPORT

International application No.
PCT/US 99/27857

Box I Observations where certain claims were found unsearchable (Continuation of item 1 of first sheet)

This International Search Report has not been established in respect of certain claims under Article 17(2)(a) for the following reasons:

1. Claims Nos.:
because they relate to subject matter not required to be searched by this Authority, namely:

2. Claims Nos.:
because they relate to parts of the International Application that do not comply with the prescribed requirements to such an extent that no meaningful International Search can be carried out, specifically:

3. Claims Nos.:
because they are dependent claims and are not drafted in accordance with the second and third sentences of Rule 6.4(a).

Box II Observations where unity of invention is lacking (Continuation of item 2 of first sheet)

This International Searching Authority found multiple inventions in this international application, as follows:

see additional sheet

1. As all required additional search fees were timely paid by the applicant, this International Search Report covers all searchable claims.
2. As all searchable claims could be searched without effort justifying an additional fee, this Authority did not invite payment of any additional fee.
3. As only some of the required additional search fees were timely paid by the applicant, this International Search Report covers only those claims for which fees were paid, specifically claims Nos.:

4. No required additional search fees were timely paid by the applicant. Consequently, this International Search Report is restricted to the invention first mentioned in the claims; it is covered by claims Nos.:

Remark on Protest

- The additional search fees were accompanied by the applicant's protest.
- No protest accompanied the payment of additional search fees.

INTERNATIONAL SEARCH REPORT

International Application No. PCT/US 99/27857

FURTHER INFORMATION CONTINUED FROM PCT/ISA/ 210

1. Claims: 1-49

1-48 :An eye-viewing apparatus having an imaging system and an illumination system arranged to reduce reflections from the eye around the pupil.

49 :An eye-viewing apparatus having a holder for its imaging and objective lenses such that the lenses can be changed out.

INTERNATIONAL SEARCH REPORT

Information on patent family members

International Application No
PCT/US 99/27857

Patent document cited in search report		Publication date	Patent family member(s)	Publication date
US 3586424	A	22-06-1971	CH 497170 A	15-10-1970
			DE 1940818 A	14-05-1970
			GB 1244529 A	02-09-1971
			JP 55045216 B	17-11-1980

US 4721378	A	26-01-1988	NONE	

US 4682866	A	28-07-1987	AU 580644 B	19-01-1989
			AU 5090685 A	03-06-1986
			CA 1257495 A	18-07-1989
			DE 3587755 D	31-03-1994
			DE 3587755 T	11-08-1994
			EP 0203939 A	10-12-1986
			JP 2044529 B	04-10-1990
			JP 62500914 T	16-04-1987
			WO 8602818 A	22-05-1986

US 4856872	A	15-08-1989	DE 3608515 A	24-09-1987
			EP 0236921 A	16-09-1987
			ES 2044847 T	16-01-1994
			JP 2040910 C	09-04-1996
			JP 7069518 B	31-07-1995
			JP 62220916 A	29-09-1987

US 4252420	A	24-02-1981	JP 1330891 C	14-08-1986
			JP 53126792 A	06-11-1978
			JP 58043090 B	24-09-1983
