

(19) World Intellectual Property Organization
International Bureau



(43) International Publication Date
30 December 2009 (30.12.2009)

(10) International Publication Number
WO 2009/157882 A1

- (51) **International Patent Classification:**
A43B 21/20 (2006.01) B29D 31/518 (2006.01)
- (21) **International Application Number:**
PCT/TR2008/000095
- (22) **International Filing Date:**
12 August 2008 (12.08.2008)
- (25) **Filing Language:** English
- (26) **Publication Language:** English
- (30) **Priority Data:**
2008/04626 24 June 2008 (24.06.2008) TR
- (71) **Applicant (for all designated States except US):** SEBATA ALYASAN KUNDURA IMALAT TICARET VE SANAYI LIMITED SIRKETI [TR/TR]; Keresteciler Sitesi Savas Cad., Selvi Sk. No:13 K:2-3, Merter, 34169 Istanbul (TR).
- (72) **Inventor; and**
- (75) **Inventor/Applicant (for US only):** DEMIRKIRAN, Ali [TR/TR]; Keresteciler Sitesi Savas Cad., Selvi Sk. No:13 K:2-3, Meter, 34169 Istanbul (TR).
- (74) **Agent:** DESTEK PATENT, INC.; Tophane Ortapazar Cad., No:7 Osmangazi, 16040 Bursa (TR).

- (81) **Designated States (unless otherwise indicated, for every kind of national protection available):** AE, AG, AL, AM, AO, AT, AU, AZ, BA, BB, BG, BH, BR, BW, BY, BZ, CA, CH, CN, CO, CR, CU, CZ, DE, DK, DM, DO, DZ, EC, EE, EG, ES, FI, GB, GD, GE, GH, GM, GT, HN, HR, HU, ID, IL, IN, IS, JP, KE, KG, KM, KN, KP, KR, KZ, LA, LC, LK, LR, LS, LT, LU, LY, MA, MD, ME, MG, MK, MN, MW, MX, MY, MZ, NA, NG, NI, NO, NZ, OM, PG, PH, PL, PT, RO, RS, RU, SC, SD, SE, SG, SK, SL, SM, ST, SV, SY, TJ, TM, TN, TR, TT, TZ, UA, UG, US, UZ, VC, VN, ZA, ZM, ZW.
- (84) **Designated States (unless otherwise indicated, for every kind of regional protection available):** ARIPO (BW, GH, GM, KE, LS, MW, MZ, NA, SD, SL, SZ, TZ, UG, ZM, ZW), Eurasian (AM, AZ, BY, KG, KZ, MD, RU, TJ, TM), European (AT, BE, BG, CH, CY, CZ, DE, DK, EE, ES, FI, FR, GB, GR, HR, HU, IE, IS, IT, LT, LU, LV, MC, MT, NL, NO, PL, PT, RO, SE, SI, SK, TR), OAPI (BF, BJ, CF, CG, CI, CM, GA, GN, GQ, GW, ML, MR, NE, SN, TD, TG).

Published:

— with international search report (Art. 21(3))

(54) **Title:** SHOE HEEL WITH POLYURETHANE DERIVATIVE AND PRODUCTION METHOD THEREOF

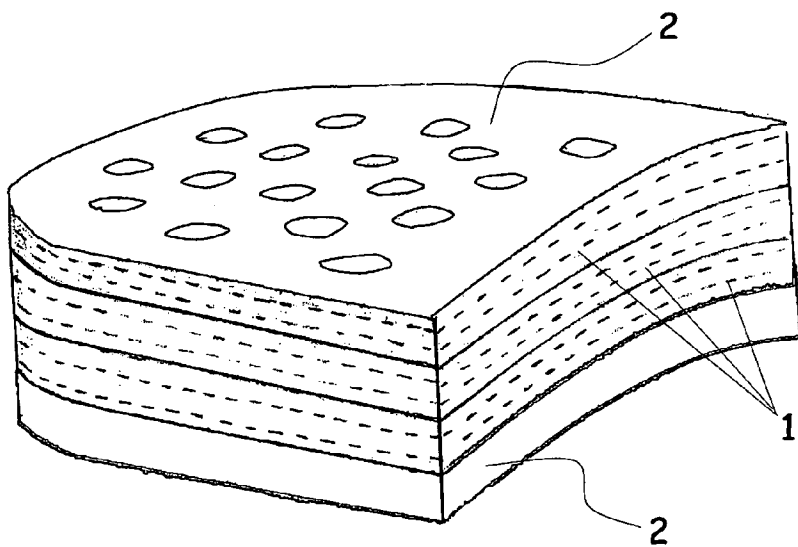

(57) **Abstract:** The invention relates to a shoe heel with polyurethane derivative (2) used in men's and women's shoes, which is lightweight, easy to manufacture and has a flexible structure, and to the production method thereof.

Figure - 1

SHOE HEEL WITH POLYURETHANE DERIVATIVE AND PRODUCTION METHOD THEREOF

Technical Field

5

The invention relates to the heel used in men's and women's shoes.

10

The invention relates in particular to shoe heel with polyurethane derivative used in men's and women's shoes which is light, easy to produce and has a flexible structure and production method thereof.

Background of the Invention

15

Today, the shoe sector is advancing rapidly and various models are offered on the market with aesthetics and elegance given a particular importance. It is of great importance that said shoes, in addition to being aesthetically appealing and elegant, do not adversely affect foot health and shoes that are comfortable to use are developed.

20

One of the crucial parts of shoes that affect foot health is the heelpiece, known as the shoe's heel part.

25

With the heel being the part which carries the load of the body, it is important in terms of foot health that this part is comfortable.

30

Because the heels, used in the present state of the art, do not produce flexion in a desired manner during walking, they cause pain in our feet and heels at the end of the day. Heels, which cannot provide full flexion by the nature of the materials used, also, being rigid, apply a pressure to the heel zone during walking.

Again, because of the nature of the material used, said heel is heavy and this increases the total weight of the shoes and causes fatigue in the feet of the user.

- 5 Difficulties are experienced from time to time in the production of said heels. In terms of the process, it is a long and laborious work.

In today's technology, materials such as IMITATION LEATHER, MDF, HDF, which are arduous to prepare are being used for the production of heels.

- 10 Processes such as carving out the insides of the heels produced with said materials, affixing the layers one by one, as well as bringing along additional workmanship, extend production time and complicate the production.

- 15 The difficulty of bonding the leather which is placed in front of the said heel also causes problems experienced in the production.

- In the present state of the art, in a helpful model application, number TR 2005 00060, regarding the subject, the expressions "The presence of a leverage system which applies the sole profile most accommodating for human and foot health, made to conform to the sole profile of our feet and with the geometric system of the shoe sole, used for pressing on the ground and lifting off the heel, with a leverage support to press on the ground and the road, with a breadthwise leverage support at the joining point of the foot sole border and the foot talus foot sole border, the functioning of the leverage and lifting the heel off also
- 20 when the body weight is added and facilitating a forward motion of the leg simultaneously with the step with the body in comfort and, with the repeating of our steps in both of the feet, ensuring that effort is dispensed in the shoe which we have developed" are mentioned.

- 30 In the application mentioned, a mechanical shoe providing ease of walking is referred to.

Again in the present state of the art, in a helpful model application, number TR 2004 02324, regarding the subject, the expressions "The invention relates to a heelpiece (heel) machine, used in the production of heels that are used in feet protective and rest wear such as shoes, high boots, boots and slippers, comprising at least one heel, at least one heel compression jaw which shapes the said heel and which embodies it at least one heel pad and which comprises arms with mobile upper and lower sections that are placed near the said pad in order to form the ovalness of the external and the internal sides." are mentioned.

10

Also in the application referred to a machine us for heel production is mentioned.

Due to the disadvantages mentioned above, a quest was embarked on, for an innovation in the production of shoe heels.

15

Disclosure of the Invention

Based on this state of the art, the object of the invention is to construct a heel which eliminates the disadvantages mentioned.

20

Another object of the invention is to construct a lightweight structure that provides ease for the user.

Another object of the invention is the construct a structure which is easy to manufacture due to the fact that it does not involve processes such as the carving out of the insides of said heels and binding the layers one by one.

25

Another object of the invention is to construct a structure having a shorter production time.

30

Another object of the invention is to construct a structure which enables the flexion of the heel zone of the feet in the desired form during walking.

Another object of the invention is to construct a structure which prevents foot health problems which may arise subsequent to walking, by providing ease of walking for the user.

Description of the Figures

- 10 Figure – 1 Side view of the polyurethane derivative heel, the subject matter of the invention
Figure – 2 Bottom view of the cover of the polyurethane derivative heel, the subject matter of the invention
Figure – 3 Side view of a different embodiment of the invention
15 Figure – 4 Bottom view of a different embodiment of the invention

Reference Numbers

1. Coating Layer
20 2. Shoe Heel with Polyurethane Derivative
3. Cover
3.1 Leather

Detailed Description of the Invention

25 The invention relates to a shoe heel with polyurethane derivative (2) used in men's and women's shoes, which is lightweight, easy to manufacture and has a flexible structure, and to the production method thereof.

30 In Figure -1 the side view of the polyurethane derivative shoe heel (2), the subject matter of the invention, is shown.

The invention comprises the shoe heel with polyurethane derivative (2) and the coating layer (1) positioned around the said shoe heel with polyurethane derivative (2).

- 5 For the production of the invention, metal forms in the shape of the heel are used. Firstly the coating layer (1) prepared in various millimeters and layers are wrapped onto the inner side surfaces of the said metal form. As for the inner surface, adhesive is applied on the inner face of the said coating layer (1).
- 10 Later, a polyurethane or derivative material is injected into the said metal form. The said polyurethane material assumes the heel shape of the form inside the said form and takes shape as the shoe heel with polyurethane derivative (2). The said shoe heel with polyurethane derivative (2) is bonded to the coating layer (1) wrapped around it via the adhesive on the internal surface of said
- 15 coating layer (1).

Thus, the said shoe heel with polyurethane derivative (2) is removed from the form, with the coating layer (1) wrapped around it.

- 20 In a preferred embodiment of the invention the said coating layer (1) is made from leather or imitation leather.

In a preferred embodiment of the invention, the leather (3.1) is positioned on the front area of the said cover (3).

25

The external appearance of the shoe heel with polyurethane derivative (2) mentioned is that of an imitation leather or leather heel, since completely enveloped in the coating layer (1).

- 30 Because that section of the mentioned polyurethane derivative shoe heel (2) which is in contact with the ground assumes the shape of the form it is used as

the cover (heel base) (3). Thus, the cover (3) section is also removed from the form in one piece, without any need for an additional layer.

5 In the preferred embodiments of the invention the mentioned polyurethane derivative shoe heel (2) is made from a TPU, poly, PVC type material.

The scope of protection of this application is specified in the Claims section and may not be limited to those described in the foregoing absolutely for representative purposes. It is evident that a person specialized in the
10 technology can construct the innovation introduced with the invention by using similar constructions and/or can apply this construct in other fields used in the technology serving a similar purpose. Therefore, it is also evident that such constructs shall be devoid of the criteria of innovation, and particularly of surpassing the present state of the art.

15

CLAIMS

1. The invention relates to the production method of a lightweight, easy to manufacture shoe heel with a flexible structure used in men's and women's shoes characterized in that it comprises the steps of; covering a coating layer (1) on the internal side surfaces of at least one metal form produced in the form of the shoe heel, application of adhesive on the inner surface of the coating layer (1), injection of polyurethane or a derivative material into the metal form enwrapped in the coating layer (1), binding of the polyurethane or derivative material on the coating layer (1) and assuming the heel shape of the metal form and thus removal from the form in the shape of the shoe heel with polyurethane derivative (2).
2. A shoe heel production method according to Claim 1 characterized in that the coating layer (1) is made from either imitation leather or leather.
3. A shoe heel production method according to Claim 1 and 2 characterized in that the cover (3) front area of the shoe heel with polyurethane derivative (2), positioned as the section which presses on the ground when removed from the form, is connected with leather (3.1).
4. A shoe heel production method according to any one of the preceding claims characterized in that the shoe heel with polyurethane derivative (2) is made from a TPU, poly, PVC type material.
5. The invention relates to a lightweight, easy to manufacture shoe heel with a flexible structure used in men's and women's shoes characterized in that it comprises at least one shoe heel with polyurethane derivative (2), at least one coating layer (1) enveloping the shoe heel with polyurethane derivative (2).

6. A shoe heel with polyurethane derivative (2) according to Claim 5 characterized in that it comprises at least one cover (3) positioned at the bottom section of the shoe heel with polyurethane derivative (2).
- 5 7. A shoe heel with polyurethane derivative (2) according to Claim 5 and 6 characterized in that it comprises leather (3.1) positioned on the front area of the cover (3).

1/2

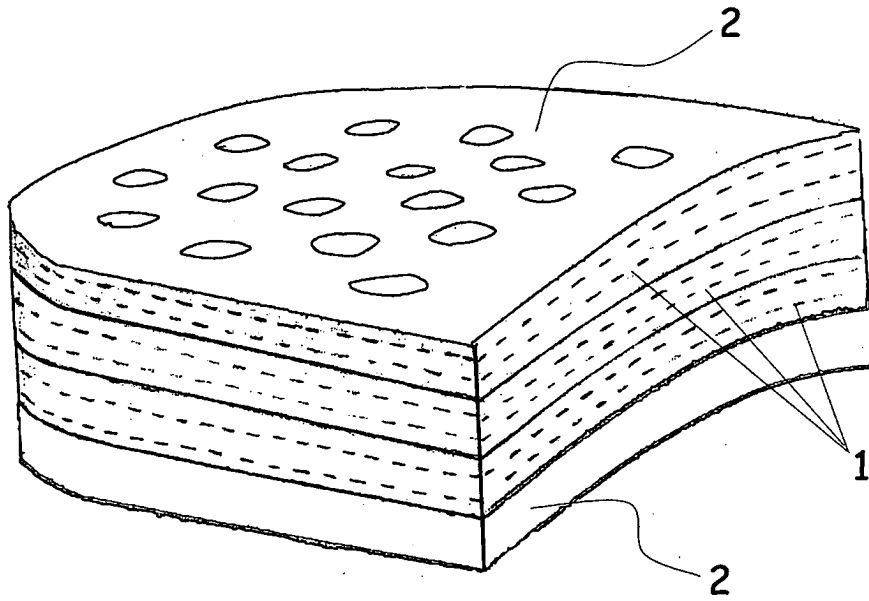

Figure - 1

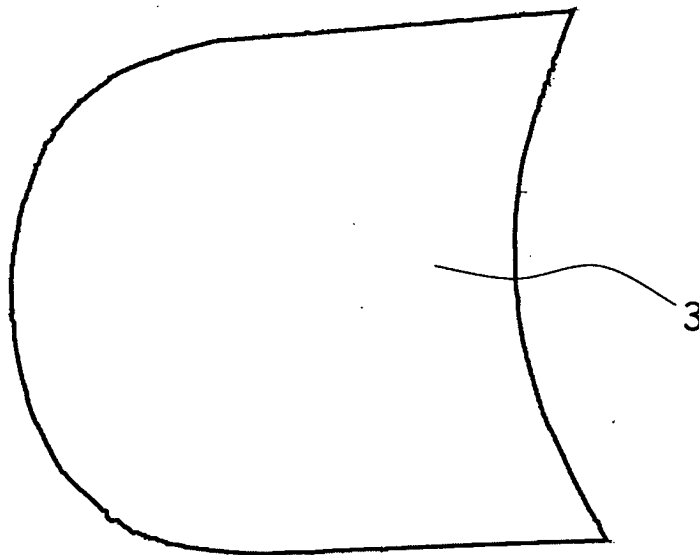

Figure - 2

2/2

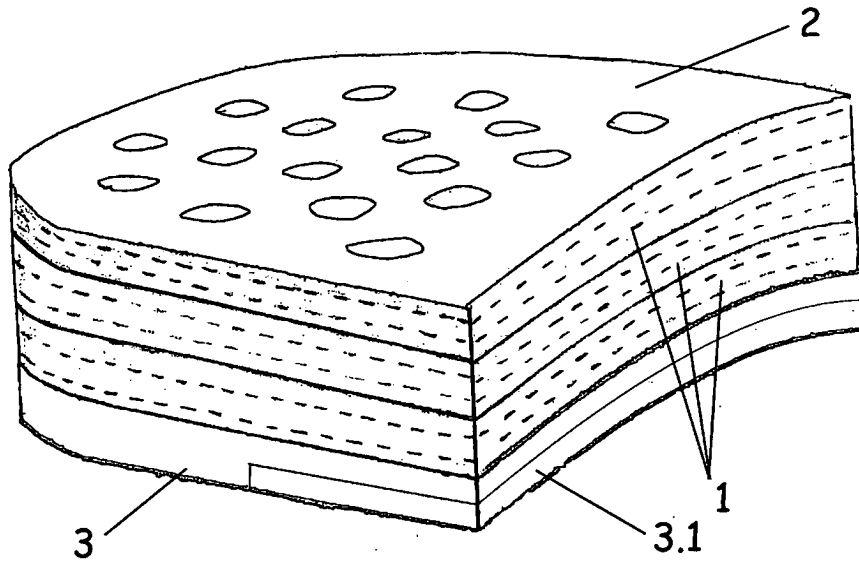

Figure - 3

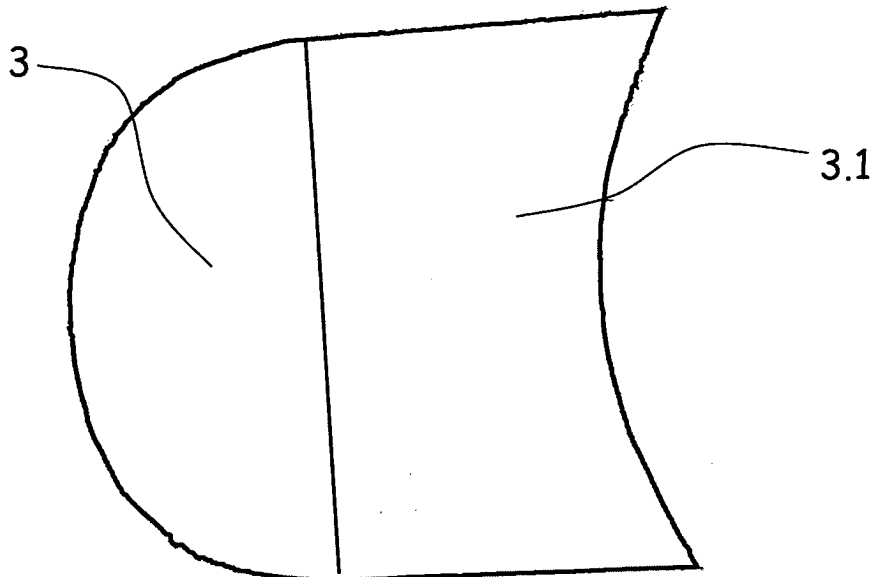

Figure - 4

INTERNATIONAL SEARCH REPORT

International application No
PCT/TR2008/000095

A. CLASSIFICATION OF SUBJECT MATTER
INV. A43B21/20 B29D31/518

According to International Patent Classification (IPC) or to both national classification and IPC

B. FIELDS SEARCHED

Minimum documentation searched (classification system followed by classification symbols)
A43B B29D

Documentation searched other than minimum documentation to the extent that such documents are included in the fields searched

Electronic data base consulted during the international search (name of data base and, where practical, search terms used)
EPO-Internal

C. DOCUMENTS CONSIDERED TO BE RELEVANT

Category*	Citation of document, with indication, where appropriate, of the relevant passages	Relevant to claim No.
Y	WO 2004/047580 A (SALVATORE FERRAGAMO ITALIA S P [IT]; SUAREZ ADOLFO JAVIER [US]; PUCCIO) 10 June 2004 (2004-06-10) the whole document	1-7
Y	FR 1 394 958 A (CLAEYS) 9 April 1965 (1965-04-09) page 1, left-hand column, last paragraph - right-hand column, paragraph 1 page 2, left-hand column, last line - right-hand column, paragraph 1; figures	1-7
X	GB 2 029 689 A (TOOLSTRADE LTD) 26 March 1980 (1980-03-26)	1-6
Y	page 2, line 46 - line 112; figures	7
	-/--	

Further documents are listed in the continuation of Box C.

See patent family annex.

* Special categories of cited documents :

- *A* document defining the general state of the art which is not considered to be of particular relevance
- *E* earlier document but published on or after the international filing date
- *L* document which may throw doubts on priority claim(s) or which is cited to establish the publication date of another citation or other special reason (as specified)
- *O* document referring to an oral disclosure, use, exhibition or other means
- *P* document published prior to the international filing date but later than the priority date claimed

- *T* later document published after the international filing date or priority date and not in conflict with the application but cited to understand the principle or theory underlying the invention
- *X* document of particular relevance; the claimed invention cannot be considered novel or cannot be considered to involve an inventive step when the document is taken alone
- *Y* document of particular relevance; the claimed invention cannot be considered to involve an inventive step when the document is combined with one or more other such documents, such combination being obvious to a person skilled in the art.
- *G* document member of the same patent family

Date of the actual completion of the international search

9 March 2009

Date of mailing of the international search report

19/03/2009

Name and mailing address of the ISA/
European Patent Office, P.B. 5818 Patentlaan 2
NL - 2280 HV Rijswijk
Tel. (+31-70) 340-2040,
Fax: (+31-70) 340-3016

Authorized officer

Schölvinc, Thérèse

INTERNATIONAL SEARCH REPORT

International application No
PCT/TR2008/000095

G(Continuation). DOCUMENTS CONSIDERED TO BE RELEVANT		
Category*	Citation of document, with indication, where appropriate, of the relevant passages	Relevant to claim No.
Y	CH 90 683 A (HERFELD OTTO [CH]) 16 September 1921 (1921-09-16) the whole document -----	7
X	FR 2 017 441 A (SEMPERIT AG) 22 May 1970 (1970-05-22) the whole document -----	5
A	FR 2 036 513 A (NICOUL ETS) 24 December 1970 (1970-12-24) the whole document -----	1-7
A	FR 2 552 702 A (CHABEAUTE ETS [FR]) 5 April 1985 (1985-04-05) the whole document -----	1-7

INTERNATIONAL SEARCH REPORT

Information on patent family members

International application No

PCT/TR2008/000095

Patent document cited in search report	A	Publication date	Patent family member(s)	Publication date
WO 2004047580	A	10-06-2004	AT 408352 T AU 2003288530 A1 CA 2485676 A1 CN 1691902 A EP 1565084 A1 JP 2006507870 T KR 20050084788 A MX PA04011304 A US 2007256327 A1	15-10-2008 18-06-2004 10-06-2004 02-11-2005 24-08-2005 09-03-2006 29-08-2005 14-02-2005 08-11-2007
FR 1394958	A	09-04-1965	NONE	
GB 2029689	A	26-03-1980	NONE	
CH 90683	A	16-09-1921	NONE	
FR 2017441	A	22-05-1970	AT 296082 B BE 738505 A CH 494547 A DE 1944722 A1 GB 1229344 A NL 6913094 A US 3593437 A	25-01-1972 16-02-1970 15-08-1970 12-03-1970 21-04-1971 09-03-1970 20-07-1971
FR 2036513	A	24-12-1970	NONE	
FR 2552702	A	05-04-1985	NONE	